KB464AO60 (KLB-521 O)

1. Descriptions

KB464AO60 (KLB-521 O) is a high bright AlInGaP orange LED and has the optimized optical characteristics. Technology : AlInGaP

2. Features

- ◆ Small Footprint Surface Mount Package (4.6 L × 4.7 W × 3.3 H [mm])
- ◆ Forward Voltage(VF) from 1.8 to 2.5V @ Forward Current(IF)=20mA
- ◆ Operation Temperature from -30℃ to +85℃
- ◆ Soldering methods : IR reflow soldering
- ◆ Taping : 8 mm conductive black carrier tape & antistatic clear cover tape

3. Application

- ◆ Automotive : audio and watch back light
- ◆ Indoor Display Modules
- ◆ Signal and symbol luminaire
- ◆ Amusement

The contents of this data sheet are subject to change without advance notice for the purpose of improvement.
When using this product, would you please refer to the latest specifications.

KB464AO60 (KLB-521 O)

4. Outline Dimensions and Material Descriptions

◆ Outline Dimensions

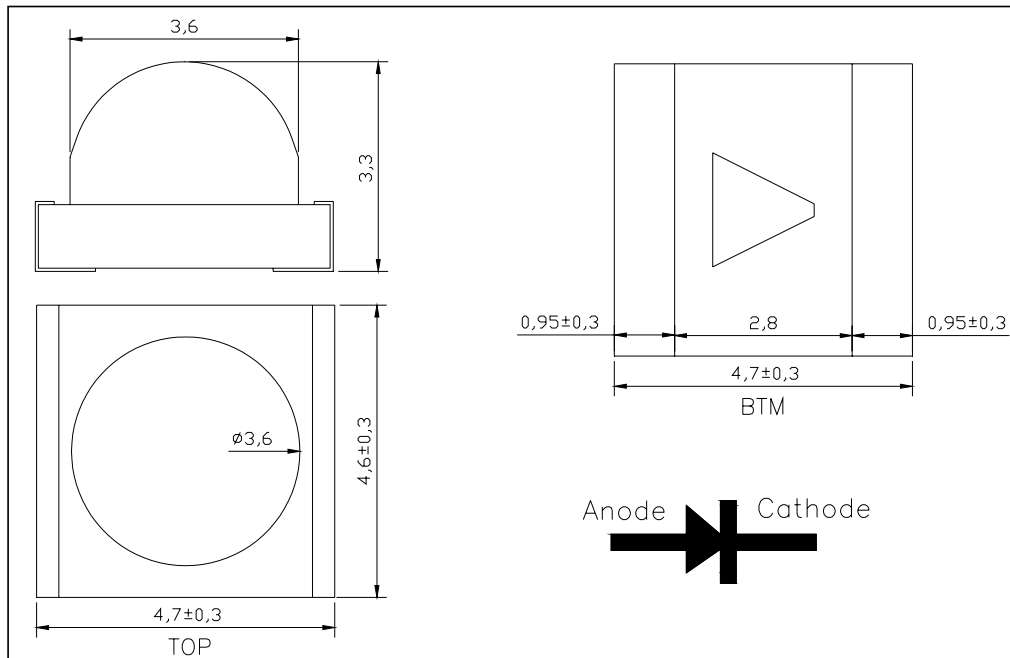

◆ Material Descriptions

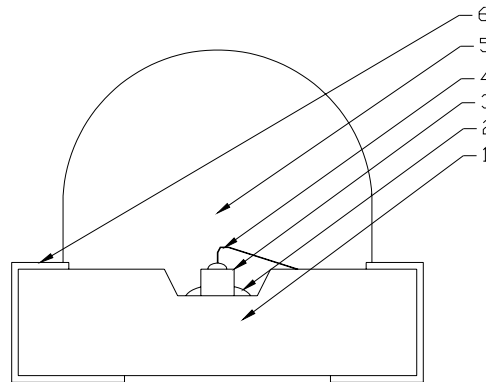

| No. | ITEM | Material |
|-----|----------|-------------|
| ① | Package | PCB |
| ② | Paste | Ag Epoxy |
| ③ | LED Chip | AllnGaP |
| ④ | Wire | Au |
| ⑤ | EMC | Clear Epoxy |
| ⑥ | Lead | Cu |

The contents of this data sheet are subject to change without advance notice for the purpose of improvement. When using this product, would you please refer to the latest specifications.

KB464AO60 (KLB-521 O)

5. Absolute Maximums

| ITEM | Symbol | MIN | MAX | Unit | Conditions |
|------------------------------------|-----------|-----|-----|------|------------|
| Forward Current | I_F | - | 30 | mA | |
| Peak Forward Current ^{*1} | I_{FP} | - | 100 | mA | |
| Power Dissipation | P_D | - | 75 | mW | |
| Reverse Voltage | V_R | - | 5 | V | |
| Operating Temperature | T_{opr} | -30 | 85 | °C | |
| Storage Temperature | T_{stg} | -40 | 100 | °C | |
| Soldering Temperature* 2 | T_{sd} | | 260 | °C | 5 Sec |

*1. Duty Ratio $\leq 1/10$, @1 kHz

*2. Soldering time ≤ 5 Sec

6. Electro-Optical Characteristics ($T_A = 25^\circ\text{C}$)

| ITEM | Symbol | MIN | TYP | MAX | Unit | Conditions |
|---------------------|-----------------|-----|----------|-----|---------------|-------------------|
| Forward Voltage | V_F | 1.8 | 2.1 | 2.5 | V | $I_F=20\text{mA}$ |
| Intensity | I_V | 1 | 2 | - | cd | $I_F=20\text{mA}$ |
| Doninant Wavelength | W_D | 600 | - | 616 | nm | $I_F=20\text{mA}$ |
| Reverse Current | I_R | - | - | 50 | μA | $V_R=5\text{V}$ |
| FWHM | $\Delta\lambda$ | - | 15 | - | nm | $I_F=20\text{mA}$ |
| Half angle | $\Delta\theta$ | | ± 40 | | deg | $I_F=20\text{mA}$ |

The contents of this data sheet are subject to change without advance notice for the purpose of improvement.
When using this product, would you please refer to the latest specifications.

7. Characteristic Graphs

Forward current vs. Ambient temperature

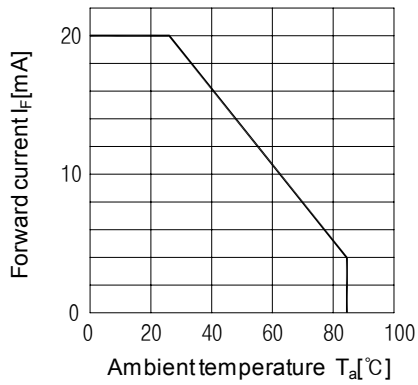

Radiant Intensity vs. Forward current

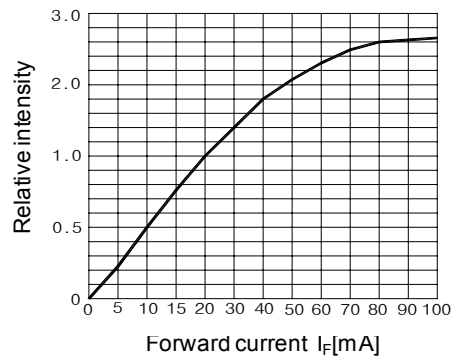

Relative radiant intensity vs. Ambient temperature

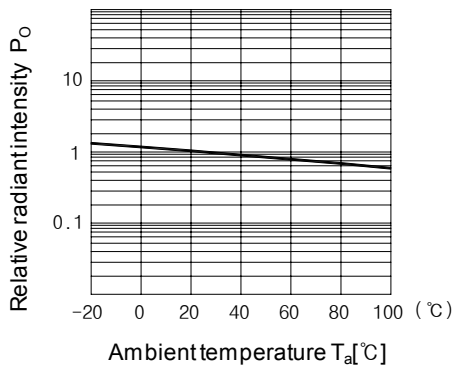

Relative intensity vs. Wavelength

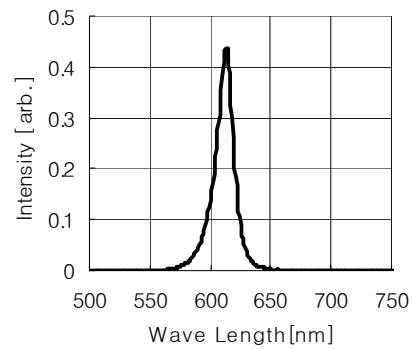

Forward current vs. Forward voltage

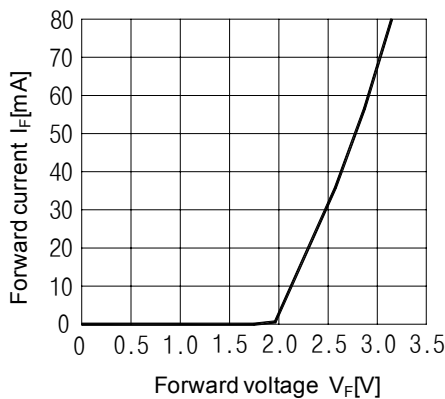

Radiant Pattern

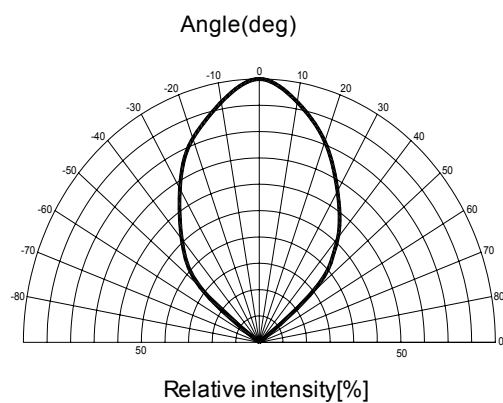

The contents of this data sheet are subject to change without advance notice for the purpose of improvement. When using this product, would you please refer to the latest specifications.