

Description

- Suitable for low voltage large current drivers
- Excellent h_{FE} Linearity
- Complementary pair with DN500
- Switching Application

Ordering Information

Type NO.	Marking	Package Code
DP500	DP500	TO-92

Outline Dimensions

unit : mm

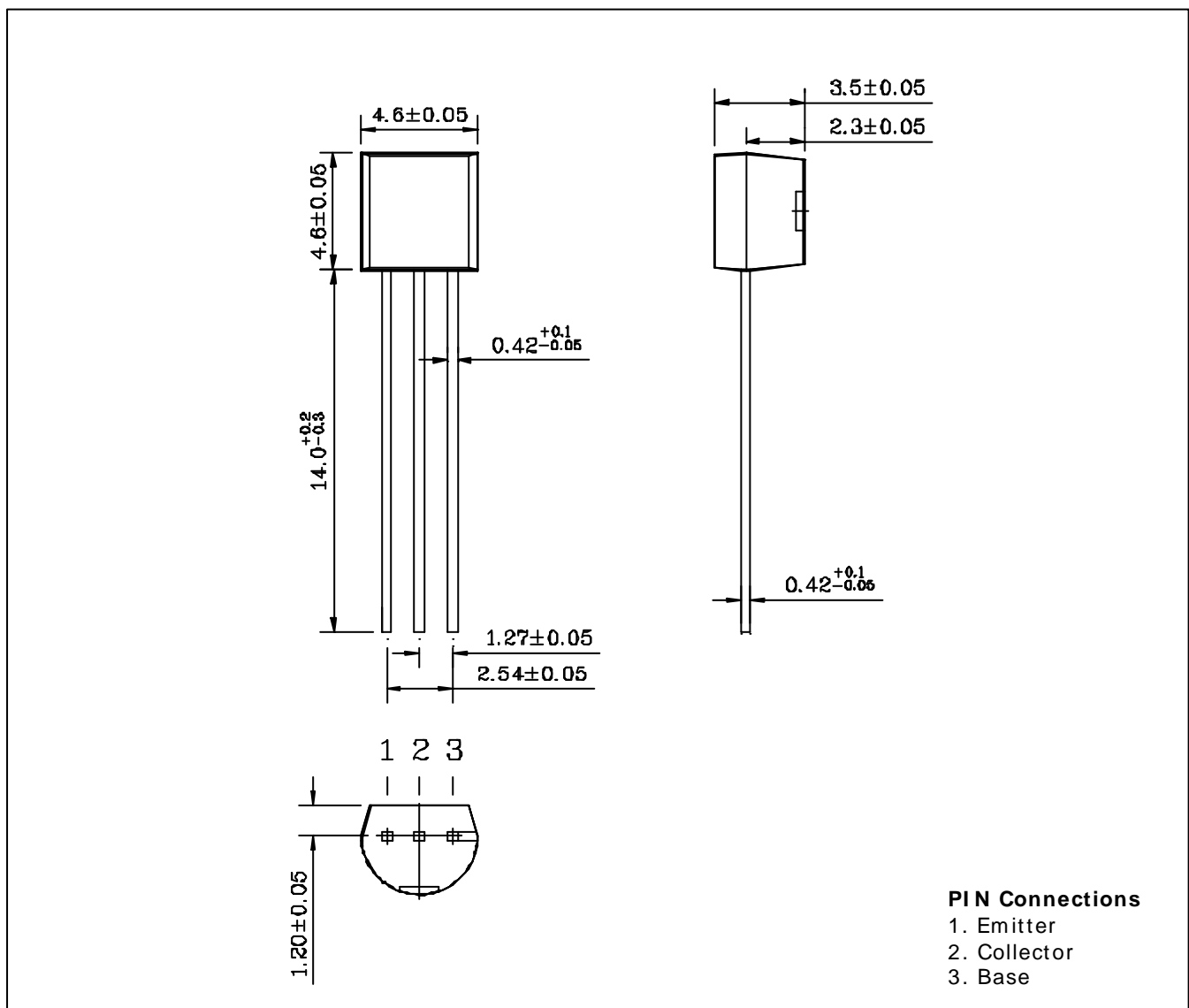

Absolute maximum ratings

(Ta=25° C)

Characteristic	Symbol	Ratings	Unit
Collector-Base voltage	V_{CBO}	- 15	V
Collector-Emitter voltage	V_{CEO}	- 12	V
Emitter-Base voltage	V_{EBO}	- 5	V
Collector current	I_C	- 5	A
Collector dissipation	P_C	625	mW
Junction temperature	T_j	150	°C
Storage temperature	T_{stg}	- 55~ 150	°C

* : When mounted on 40×40×0.8mm ceramic substate

Electrical Characteristics

(Ta=25° C)

Characteristic	Symbol	Test Condition	Min.	Typ.	Max.	Unit
Collector-Base breakdown voltage	BV_{CBO}	$I_C = -50\mu A, I_E = 0$	-15	-	-	V
Collector-Emitter breakdown voltage	BV_{CEO}	$I_C = -1mA, I_B = 0$	-12	-	-	V
Emitter-Base breakdown voltage	BV_{EBO}	$I_E = -50\mu A, I_C = 0$	-5	-	-	V
Collector cut-off current	I_{CBO}	$V_{CB} = -12V, I_E = 0$	-	-	-1	μA
Emitter cut-off current	I_{EBO}	$V_{EB} = -5V, I_C = 0$	-	-	-1	μA
DC current gain	h_{FE1}	$V_{CE} = -2V, I_C = -500mA$	160	-	320	-
	h_{FE2}	$V_{CE} = -2V, I_C = -3A$	40	-	-	-
Collector-Emitter on voltage	$V_{CE(sat1)}$	$I_C = -3A, I_B = -150mA$	-	-	-0.5	V
Base-Emitter on voltage	$V_{BE(sat)}$	$I_C = -3A, I_B = -150mA$	-	-	-1.2	V
Transition frequency	f_T	$V_{CB} = -5V, I_C = -500mA$	-	150	-	MHz
Collector output capacitance	C_{ob}	$V_{CB} = -10V, I_E = 0, f = 1MHz$	-	-	50	pF

Electrical Characteristic Curves

Fig. 1 $P_c - T_a$

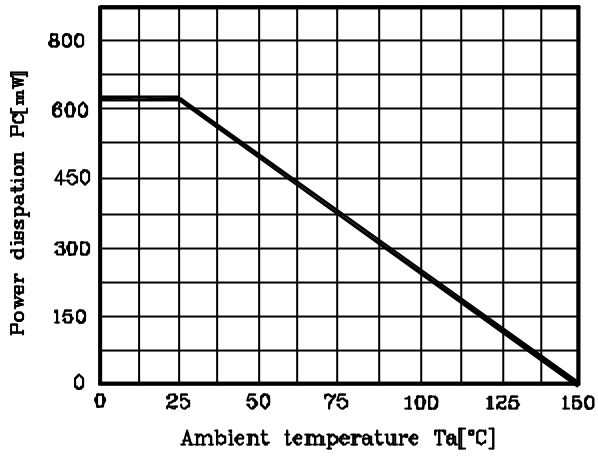

Fig. 2 $I_c - V_{BE}$

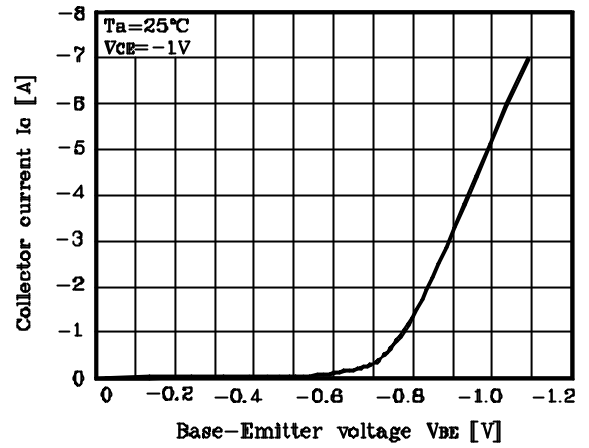

Fig. 3 $h_{FE} - I_c$

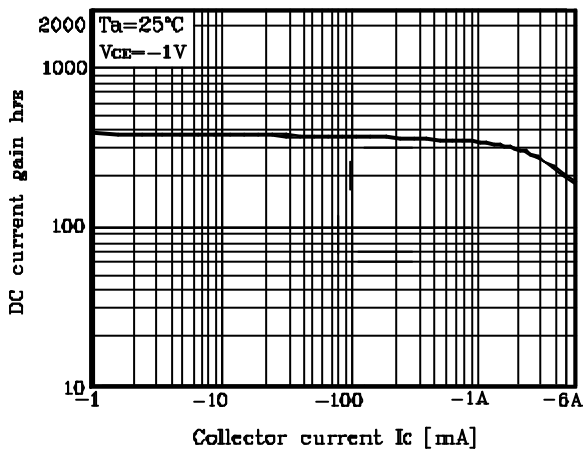

Fig. 4 $V_{CE(sat)} - I_c$

