

## Description

- Audio power amplifier application

## Features

- High  $h_{FE}$  :  $h_{FE} = 100 \sim 320$
- Complementary pair with 2SC5344

## PIN Connection

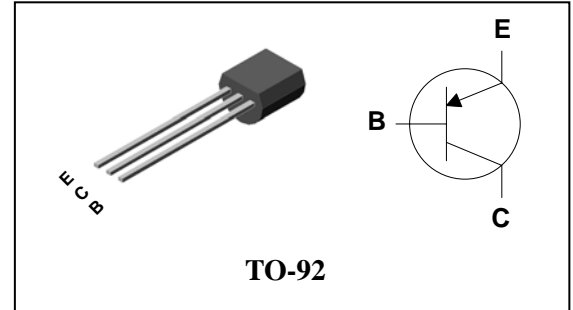

## Ordering Information

| Type NO. | Marking | Package Code |
|----------|---------|--------------|
| 2SA1981  | A1981   | TO-92        |

## Absolute maximum ratings

(Ta=25°C)

| Characteristic            | Symbol    | Ratings | Unit |
|---------------------------|-----------|---------|------|
| Collector-Base voltage    | $V_{CBO}$ | -35     | V    |
| Collector-Emitter voltage | $V_{CEO}$ | -30     | V    |
| Emitter-Base voltage      | $V_{EBO}$ | -5      | V    |
| Collector current         | $I_C$     | -800    | mA   |
| Collector dissipation     | $P_C$     | 500     | mW   |
| Junction temperature      | $T_j$     | 150     | °C   |
| Storage temperature       | $T_{stg}$ | -55~150 | °C   |

## Electrical Characteristics

(Ta=25°C)

| Characteristic                       | Symbol        | Test Condition                     | Min. | Typ. | Max. | Unit    |
|--------------------------------------|---------------|------------------------------------|------|------|------|---------|
| Collector-Base breakdown voltage     | $BV_{CBO}$    | $I_C = -500\mu A, I_E = 0$         | -35  | -    | -    | V       |
| Collector-Emitter breakdown voltage  | $BV_{CEO}$    | $I_C = -1mA, I_B = 0$              | -30  | -    | -    | V       |
| Emitter-Base breakdown voltage       | $BV_{EBO}$    | $I_E = -50\mu A, I_C = 0$          | -5   | -    | -    | V       |
| Collector cut-off current            | $I_{CBO}$     | $V_{CB} = -35V, I_E = 0$           | -    | -    | -0.1 | $\mu A$ |
| Emitter cut-off current              | $I_{EBO}$     | $V_{EB} = -5V, I_C = 0$            | -    | -    | -0.1 | $\mu A$ |
| DC current gain                      | $h_{FE}^*$    | $V_{CE} = -1V, I_C = -100mA$       | 100  | -    | 320  | -       |
| Collector-Emitter saturation voltage | $V_{CE(sat)}$ | $I_C = -500mA, I_B = -20mA$        | -    | -    | -0.5 | V       |
| Transition frequency                 | $f_T$         | $V_{CE} = -5V, I_E = 10mA$         | -    | 120  | -    | MHz     |
| Collector output capacitance         | $C_{ob}$      | $V_{CB} = -10V, I_E = 0, f = 1MHz$ | -    | 19   | -    | pF      |

 \* :  $h_{FE}$  rank / O : 100~200, Y : 160~320

Electrical Characteristic Curves

Fig. 1 Pc-Ta

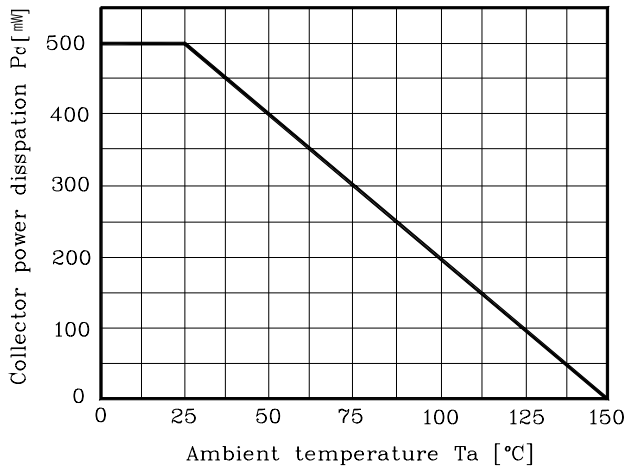

Fig. 2 IC - VBE

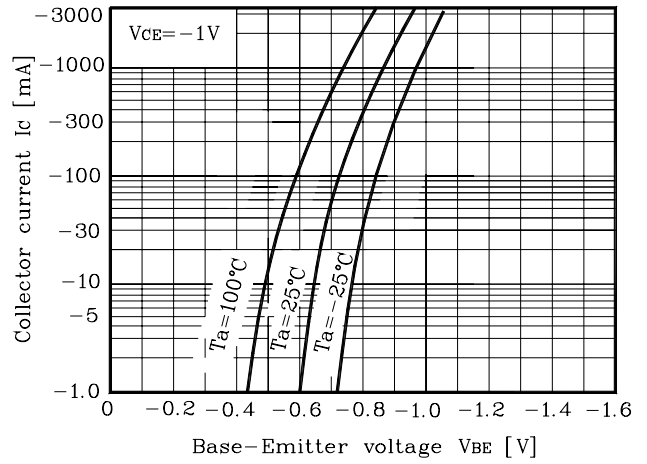

Fig. 3 IC - VCE

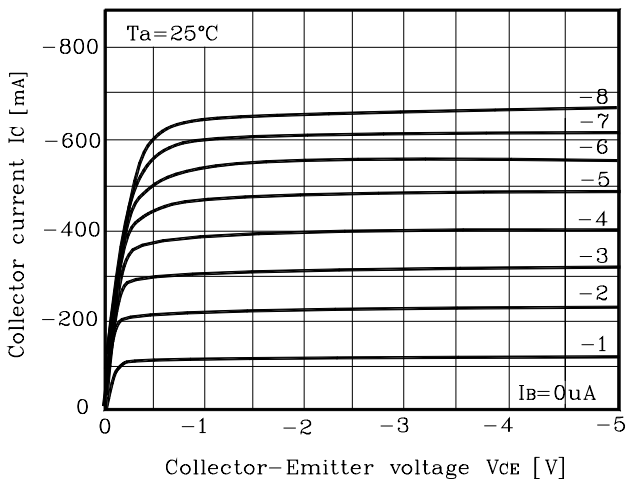

Fig. 4 hFE - IC

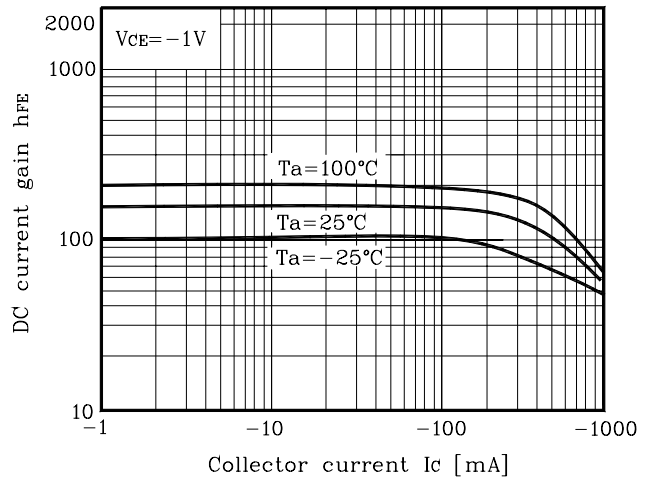
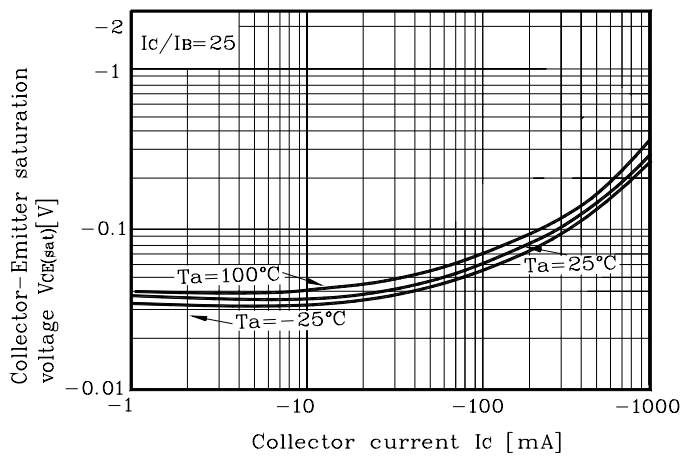
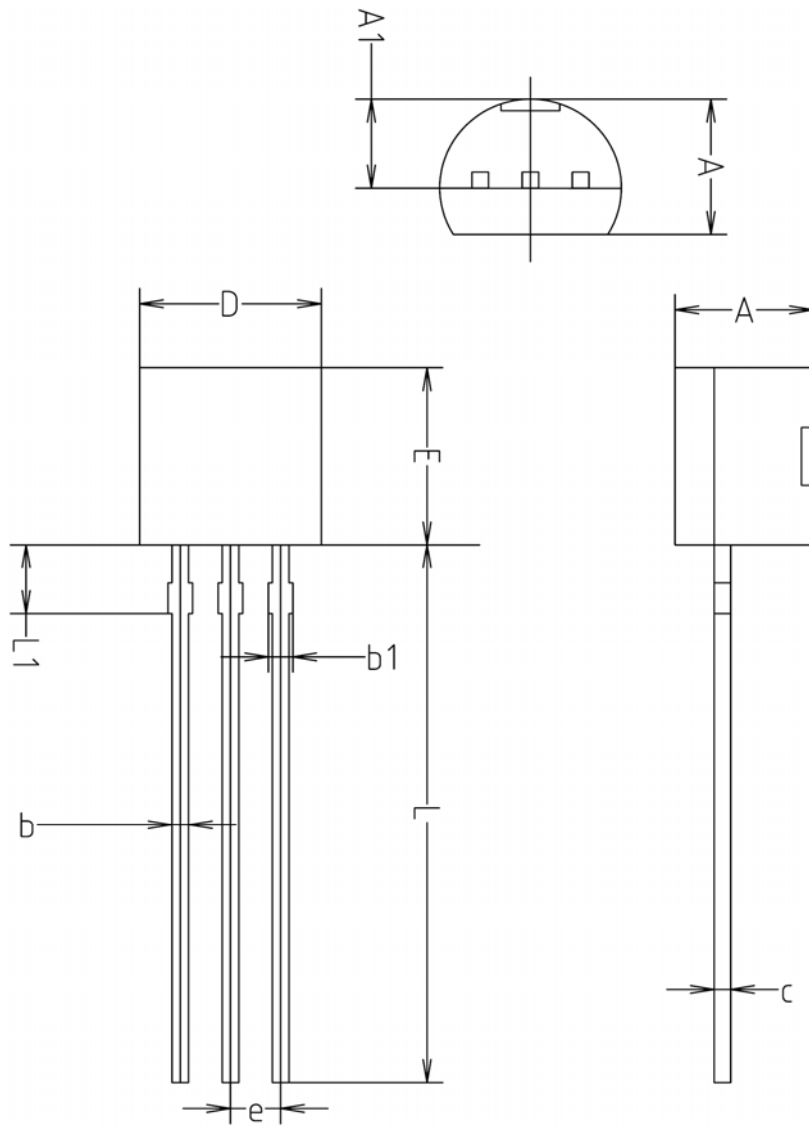

Fig. 5 VCE(SAT) - IC



Outline Dimension



| SYMBOL | MILLMETERS(mm) |         |         |
|--------|----------------|---------|---------|
|        | MINIMUM        | NOMINAL | MAXIMUM |
| A      | 3.40           | 3.50    | 3.66    |
| A1     | 2.46           | 2.51    | 2.59    |
| b      | 0.39           | 0.44    | 0.53    |
| b1     | 0.39           | —       | 0.63    |
| c      | 0.35           | 0.42    | 0.47    |
| D      | 4.48           | 4.60    | 4.70    |
| E      | 4.48           | 4.60    | 4.70    |
| e      | 1.17           | 1.27    | 1.37    |
| L      | 13.70          | 14.00   | 14.77   |
| L1     | 1.55           | 1.70    | 2.15    |

**The AUK Corp. products are intended for the use as components in general electronic equipment (Office and communication equipment, measuring equipment, home appliance, etc.).**

**Please make sure that you consult with us before you use these AUK Corp. products in equipments which require high quality and / or reliability, and in equipments which could have major impact to the welfare of human life(atomic energy control, airplane, spaceship, transportation, combustion control, all types of safety device, etc.). AUK Corp. cannot accept liability to any damage which may occur in case these AUK Corp. products were used in the mentioned equipments without prior consultation with AUK Corp..**

**Specifications mentioned in this publication are subject to change without notice.**