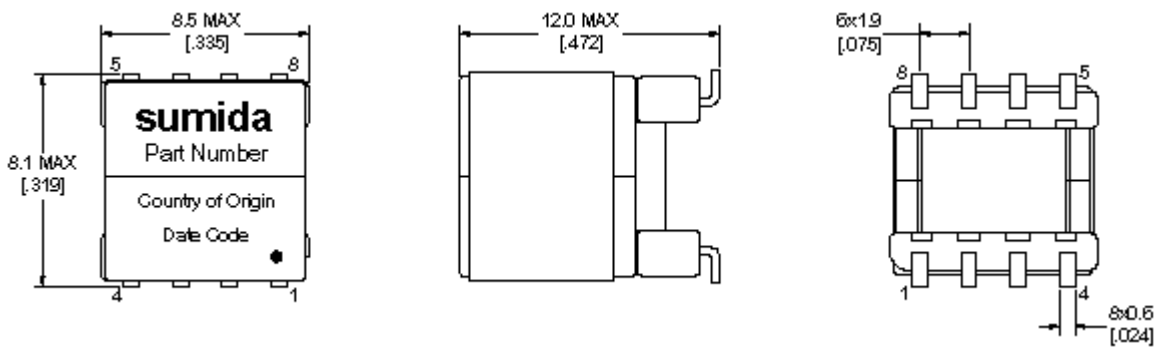
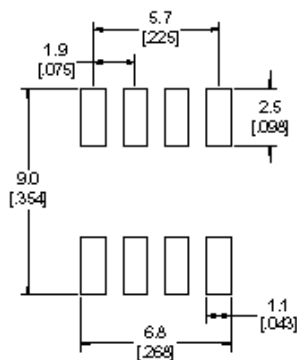
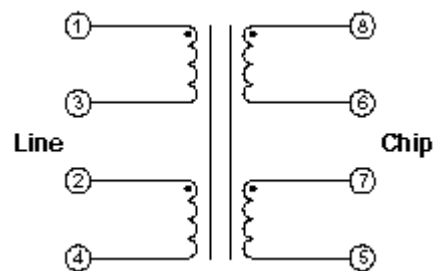

**Type: CEP711**
**◆ Product Description**

- 8.5×8.1mm Max. (L×W), 12.0mm Max. height.
- In addition to the typical versions of parameters shown here, custom parameters are available to meet your exact requirement.

**◆ Feature**

- VDSL line transformer.
- Ideally used in VDSL2 CO equipments.
- Approved by Broadcom and Conexant.
- RoHS Compliance

**◆ Dimensions (mm)**

**◆ Land Pattern (mm)**

**◆ Schematics (Bottom)**

**◆ Specification**

Part No.	Inductance (μH)	Turns ratio	THD (dB) (TYP.)	Insulation	Application
J10200	1090 ± 10%	0.90:1	-75dB(25K, 2.0V)	basic	VDSL2 CO
J10208	420 ± 10%	1.2:1	-80dB(30K, 1.4V)	basic	VDSL2 CO