

Boundary Mode Flyback Transformer for 100V Isolated Flyback Controller of Linear Tech LT3748 Solution

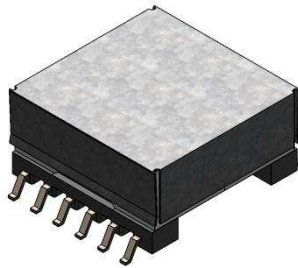

Description

- CEFD2513B Series Transformer.
- Standard EFD core construction.
- L × W × H: 32.6 × 27.0 × 15.0mm Max.
- Suited for a wide variety of industrial, automotive, medical, telecom, datacom applications, where regulated isolated outputs are required.

Dimensions – mm [inch]

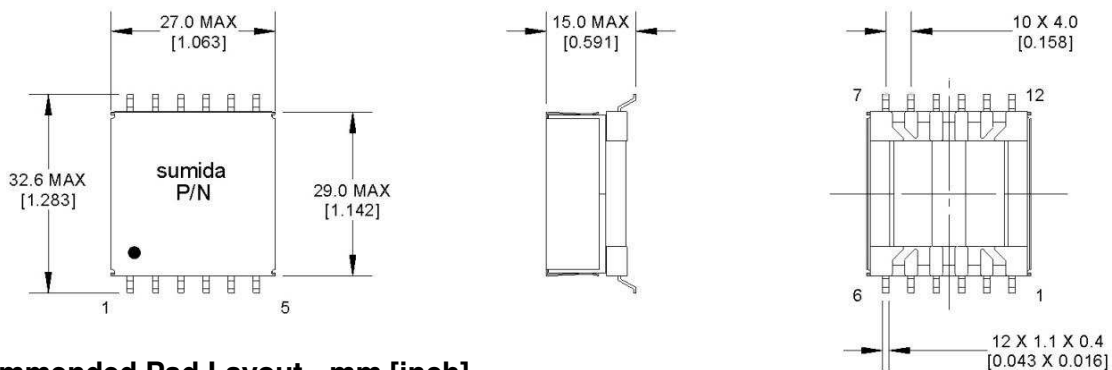

Recommended Pad Layout - mm [inch]

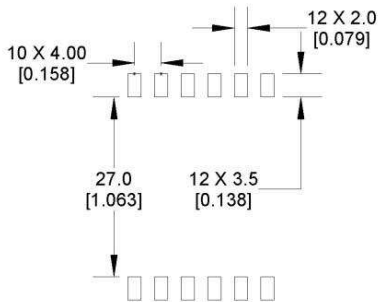

Electrical Characteristics

Part Number	Electrical Parameters			Turns Ratio (np/ns)		Inductance (uH)	Leakage Inductance Max. (uH)	DCR (mΩ Max.)		
	Vin (Pri.)	Vout (Sec)	Vout (Aux)	Pri:Aux	Pri:Sec	Pri.	Pri.	Pri.	Sec.	Aux.
10393-T029	(1-4) 5~100V	(10,11,12-7,8,9) 12V, 3.5A	(5-6) 12V, 0.025A	(1-4):(5-6) 7.0:1.0	(1-4): (10,11,12-7,8,9) 7.0:1.0	(1-4) 400	(1-4), (Tie 5+6+7+8+9+10+11+12), (Tie 2+3) 6.5	(1-4) 300	(10,11,12-7,8,9) 15	

※1. Operating and storage temperature unless otherwise noted: -40°C to +85°C

※2. Primary to secondary isolation rating is 2500Vrms unless otherwise noted.

※3. Maximum switching frequency at full load: 155kHz, Minimum switching frequency at full load: 55kHz



Schematics

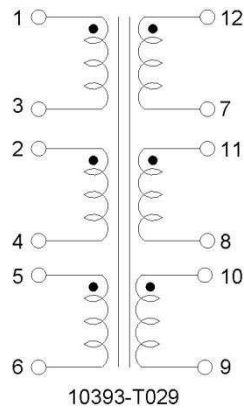

- ※1. ●Dots indicate polarity.
- ※2. (1-3) and (2-4) will be connected in series; (12-7), (11-8), (10-9) will be connected in parallel.

I.C. References

Linear Technology Solution	Sumida Part No.
DC1745A Demo Board Powering LT3748	10393-T029

- ※1. Please contact your regional sales office for additional information/details.

Please refer to the sales offices on our website - <http://www.sumida.com>

Hong Kong

Tel.+852-2880-6688
 FAX.+852-2565-9600
sales@hk.sumida.com

Tokyo

Tel.+81-3-5202-7112
 FAX.+81-3-5202-7105
sales@jp.sumida.com

Chicago

Tel.+1-847-545-6700
 FAX. +1-847-545-6720
sales@us.sumida.com

Shanghai

Tel.+86-021-5836-3299
 FAX.+86-021-5836-3266
shanghai.sales@cn.sumida.com

Seoul

Tel.+82-2-6237-0777
 FAX.+82-2-6237-0778
sales@kr.sumida.com

Oberzell

Tel.+49-8591-937-0
 FAX. +49-8591-937-103
contact@sumida-eu.com

Shenzhen

Tel.+86-755-8291-0228
 FAX.+86-755-8291-0338
shenzhen.sales@cn.sumida.com

Singapore

Tel.+65-6296-3388
 FAX.+65-6296-3390
sales@sg.sumida.com

Neumarkt

Tel.+49-9181-4509-110
 FAX. +49-9181-4509-310
infocomp@eu.sumida.com

Taipei

Tel.+886-2-8751-2737
 FAX.+886-2-8751-2738
sales@tw.sumida.com

San Jose

Tel.+1-408-321-9660
 FAX.+1-408-321-9308
sales@us.sumida.com