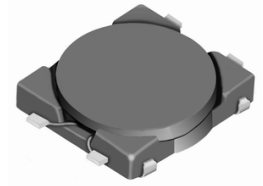
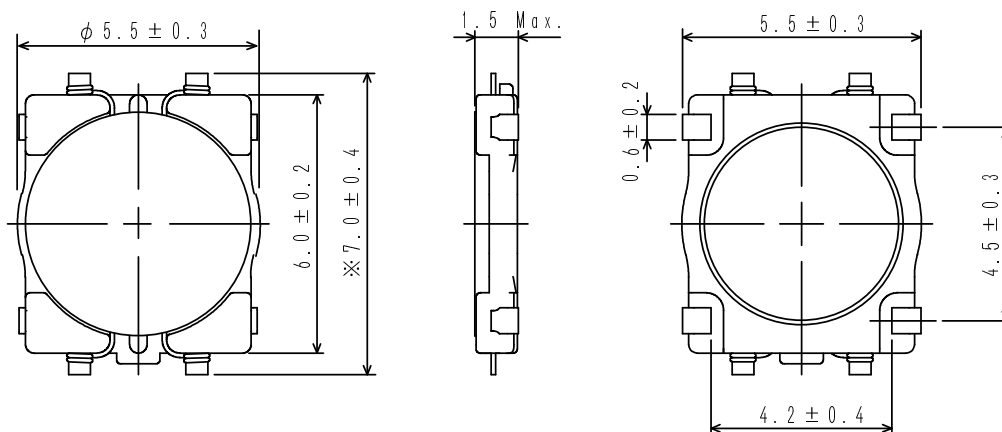
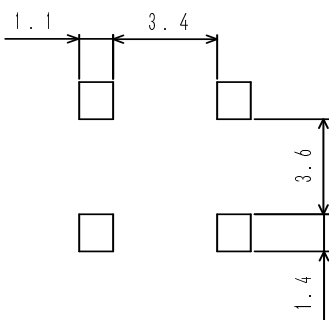
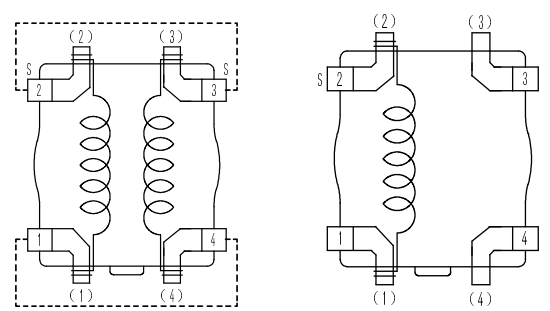

Type: CMD5D13
◆ Product Description

- 7.4 × 5.8mm Max.(L × W), 1.5mm Max. Height.
- Inductance range: 3.3 ~ 47 μH.
- Rated current range: 0.35 ~ 1.25A.
- 4 Terminal pins' type gives a flexible design as inductors or transformers(SEPIC,ZETA circuit).
- In addition to the standards versions used as power inductors shown here, custom designs as transformers(SEPIC,ZETA circuit) and inductors are also available.

◆ Feature

- Magnetically unshielded construction.
- Ideally used in portable devices such as Mobilephone, DSC/DVC, MP3, PDA, etc as DC-DC Converter inductors, specially suitable for White LED drive.
- RoHS Compliance.

◆ Dimensions (mm)

◆ Land Pattern (mm)

◆ Schematics(Bottom)

“S” is winding start.
Terminal Pins(1#) and (4#), (2#) and (3#) are short connected when used as an inductor.

Type: CMD5D13
◆ Specification

Part No. ※	Stamp	Inductance (μ H) [Within] 100kHz/1V	D.C.R.(m Ω) Max.(Typ.) (at 20°C)	Saturation Current (A) ※1	Temperature Rise current (A) ※2
CMD5D13NP-3R3M□	3R3	3.3±20%	81 (65)	1.90	1.25
CMD5D13NP-4R7M□	4R7	4.7±20%	106 (85)	1.50	1.20
CMD5D13NP-6R8M□	6R8	6.8±20%	144 (115)	1.40	0.90
CMD5D13NP-100M□	100	10±20%	187 (150)	1.00	0.85
CMD5D13NP-150M□	150	15±20%	300 (240)	0.95	0.57
CMD5D13NP-220M□	220	22±20%	431 (345)	0.80	0.54
CMD5D13NP-330M□	330	33±20%	637 (510)	0.70	0.38
CMD5D13NP-470M□	470	47±20%	875 (700)	0.55	0.35

Terminal Pins(1[#]) and (4[#]),(2[#]) and (3[#]) are short connected when measuring.

※ Description of Part Name

CMD5D13NP-3R3M□
 └── B Box
 └── C Carrier Tape

※1.Saturation current: The DC current at which the inductance decreases to 90% of it's initial value.

※2.Temperature rise current: The DC current at which the temperature rise is $\Delta t=40^{\circ}\text{C}.$ ($T_a=20^{\circ}\text{C}$)