



A62S6308A Series

Preliminary

64K X 8 BIT LOW VOLTAGE CMOS SRAM

Document Title

64K X 8 BIT LOW VOLTAGE CMOS SRAM

Revision History

<u>Rev. No.</u>	<u>History</u>	<u>Issue Date</u>	<u>Remark</u>
0.0	Initial issue	May 31, 2011	Preliminary



A62S6308A Series

Preliminary

64K X 8 BIT LOW VOLTAGE CMOS SRAM

Features

- Power supply range: 2.7V to 3.6V
- Access times: 55/70 ns (max.)
- Current:
 - A62S6308A series: Operating: 30mA (max.)
 - Standby: 5µA (max.)
- Extended operating temperature range: 0°C to 70°C for -S series, -40°C to +85°C for -SU series
- Full static operation, no clock or refreshing required
- All inputs and outputs are directly TTL-compatible
- Common I/O using three-state output
- Output enable and two chip enable inputs for easy application
- Data retention voltage: 2V (min.)
- Available in 32-pin SOP, TSOP, sTSOP (8 X 13.4mm) forward type packages
- All Pb-free (Lead-free) products are RoHS compliant

General Description

The A62S6308A is a low operating current 524,288-bit static random access memory organized as 65,536 words by 8 bits and operates on a low power supply voltage from 2.7V to 3.6V.

Inputs and three-state outputs are TTL compatible and allow for direct interfacing with common system bus structures.

Two chip enable inputs are provided for POWER-DOWN and a device enable and an output enable input are included for easy interfacing.

Data retention is guaranteed at a power supply voltage as low as 2V.

Pin Configurations

■ SOP

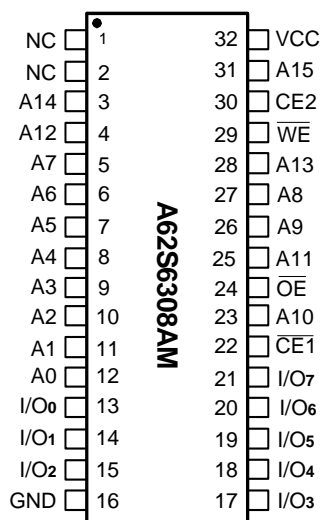

■ TSOP/(sTSOP) (forward type)

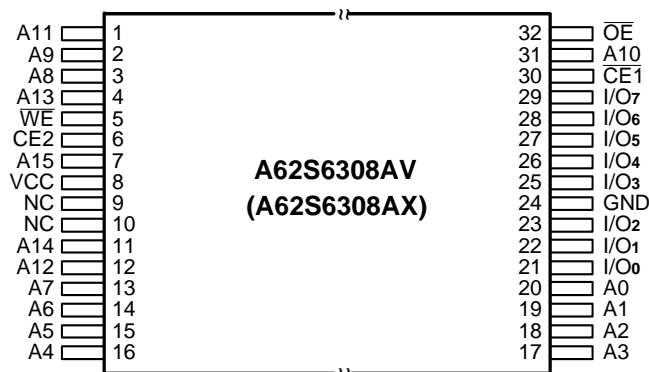

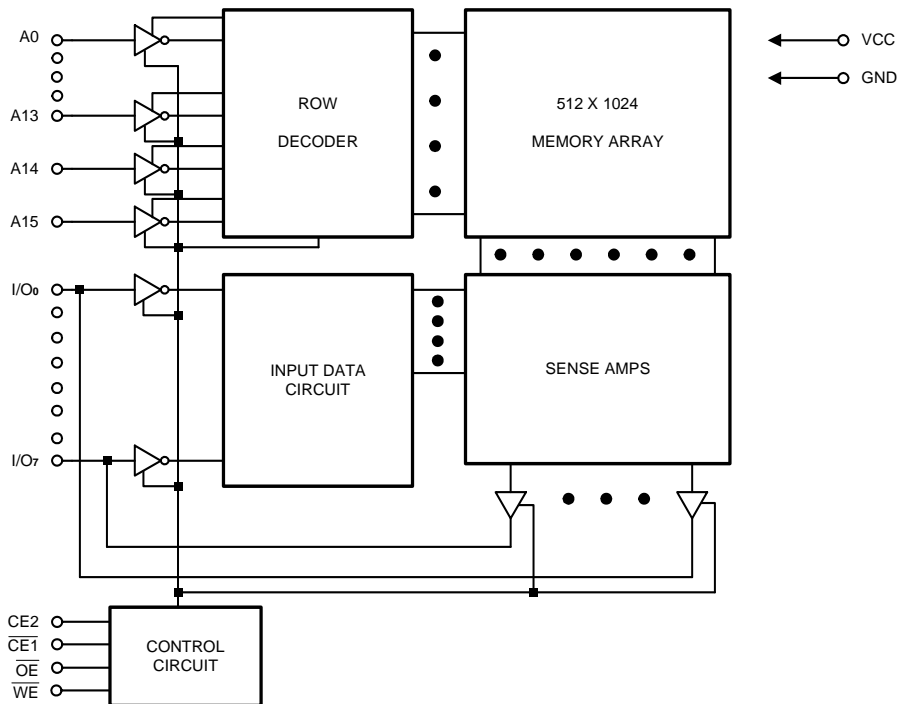
Block Diagram

Pin Descriptions - SOP

Pin No.	Symbol	Description
1,2	NC	No Connection
3 - 12, 23, 25 - 28, 31	A0 - A15	Address Inputs
13 - 15, 17 - 21	I/O ₀ - I/O ₇	Data Inputs/Outputs
16	GND	Ground
22	$\overline{CE1}$	Chip Enable
24	\overline{OE}	Output Enable
29	\overline{WE}	Write Enable
30	CE2	Chip Enable
32	VCC	Power Supply

Pin Description - TSOP/sTSOP

Pin No.	Symbol	Description
1 - 4, 7, 11 - 20, 31	A0 - A15	Address Inputs
5	\overline{WE}	Write Enable
6	CE2	Chip Enable
8	VCC	Power Supply
9, 10	NC	No Connection
21 - 23, 25 - 29	I/O ₀ - I/O ₇	Data Inputs/Outputs
24	GND	Ground
30	$\overline{CE1}$	Chip Enable
32	\overline{OE}	Output Enable

Recommended DC Operating Conditions

 (T_A = 0°C to +70°C, or -40°C to +85°C)

Symbol	Parameter	Min.	Typ.	Max.	Unit
VCC	Supply Voltage	2.7	3.0	3.6	V
GND	Ground	0	0	0	V
V _{IH}	Input High Voltage	2.2	-	VCC + 0.3	V
V _{IL}	Input Low Voltage	-0.3	-	+0.6	V
C _L	Output Load	-	-	30	pF
TTL	Output Load	-	-	1	-

Absolute Maximum Ratings*

VCC to GND -0.5V to + 4.6V
 IN, IN/OUT Volt to GND -0.5V to VCC + 0.5V
 Operating Temperature, T_{opr}
 0°C to +70°C, or -40°C to +85°C
 Storage Temperature, T_{stg} -55°C to + 125°C
 Power Dissipation, P_T 0.7W

***Comments**

Stresses above those listed under "Absolute Maximum Ratings" may cause permanent damage to this device. These are stress ratings only. Functional operation of this device at these or any other conditions above those indicated in the operational sections of this specification is not implied or intended. Exposure to the absolute maximum rating conditions for extended periods may affect device reliability.

DC Electrical Characteristics (T_A = 0°C to +70°C or -40°C to +85°C, VCC = 2.7V to 3.6V, GND = 0V)

Symbol	Parameter	Min.	Max.	Unit	Conditions
I _{LI}	Input Leakage Current	-	1	μA	V _{IN} = GND to VCC
I _{LO}	Output Leakage Current	-	1	μA	$\overline{CE1} = V_{IH}$ or $CE2 = V_{IL}$ or $\overline{OE} = V_{IH}$ or $\overline{WE} = V_{IL}$ V _{I/O} = GND to VCC
I _{CC}	Active Power Supply Current	-	3	mA	$\overline{CE1} = V_{IL}$, CE2 = V _{IH} I _{I/O} = 0mA
I _{CC1}	Dynamic Operating Current	-	30	mA	Min. Cycle, Duty = 100% $\overline{CE1} = V_{IL}$, CE2 = V _{IH} I _{I/O} = 0mA
I _{CC2}		-	3	mA	$\overline{CE1} = V_{IL}$, CE2 = V _{IH} V _{IH} = VCC, V _{IL} = 0V f = 1MHz, I _{I/O} = 0mA

DC Electrical Characteristics (continued)

Symbol	Parameter	Min.	Max.	Unit	Conditions
I _{SB}	Standby Power Supply Current	-	0.5	mA	V _{CC} ≤ 3.3V CE1 = V _{IH} or CE2 = V _{IL}
I _{SB1}		-	5	μA	V _{CC} ≤ 3.3V CE1 ≥ V _{CC} - 0.2V or CE2 ≤ 0.2V V _{IN} ≥ 0V
V _{OL}	Output Low Voltage	-	0.4	V	I _{OL} = 2.1mA
V _{OH}	Output High Voltage	2.2	-	V	I _{OH} = -1.0mA

Truth Table

Mode	CE1	CE2	OE	WE	I/O Operation	Supply Current
Standby	H	X	X	X	High Z	I _{SB} , I _{SB1}
	X	L	X	X	High Z	I _{SB} , I _{SB1}
Output Disable	L	H	H	H	High Z	I _{CC} , I _{CC1} , I _{CC2}
Read	L	H	L	H	D _{OUT}	I _{CC} , I _{CC1} , I _{CC2}
Write	L	H	X	L	D _{IN}	I _{CC} , I _{CC1} , I _{CC2}

Note: X = H or L

Capacitance (T_A = 25°C, f = 1.0MHz)

Symbol	Parameter	Min.	Max.	Unit	Conditions
C _{IN} *	Input Capacitance		6	pF	V _{IN} = 0V
C _{I/O} *	Input/Output Capacitance		8	pF	V _{I/O} = 0V

* These parameters are sampled and not 100% tested.

AC Characteristics ($T_A = 0^\circ\text{C}$ to $+70^\circ\text{C}$ or -40°C to $+85^\circ\text{C}$, $V_{CC} = 2.7\text{V}$ to 3.6V)

Symbol	Parameter	A62S6308A-55S/SU		A62S6308A-70S/SU		Unit	
		Min.	Max.	Min.	Max.		
Read Cycle							
t _{RC}	Read Cycle Time	55	-	70	-	ns	
t _{AA}	Address Access Time	-	55	-	70	ns	
t _{ACE1}	Chip Enable Access Time	$\overline{\text{CE1}}$	-	55	-	70	ns
t _{ACE2}		CE2	-	55	-	70	ns
t _{OE}	Output Enable to Output Valid	-	30	-	35	ns	
t _{CLZ1}	Chip Enable to Output in Low Z	$\overline{\text{CE1}}$	10	-	10	-	ns
t _{CLZ2}		CE2	10	-	10	-	ns
t _{OLZ}	Output Enable to Output in Low Z	5	-	5	-	ns	
t _{CHZ1}	Chip Disable to Output in High Z	$\overline{\text{CE1}}$	0	20	0	25	ns
t _{CHZ2}		CE2	0	20	0	25	ns
t _{OHZ}	Output Disable to Output in High Z	0	20	0	25	ns	
t _{OH}	Output Hold from Address Change	5	-	10	-	ns	
Read Cycle							
t _{wc}	Write Cycle Time	55	-	70	-	ns	
t _{cw}	Chip Enable to End of Write	50	-	60	-	ns	
t _{AS}	Address Setup Time	0	-	0	-	ns	
t _{AW}	Address Valid to End of Write	50	-	60	-	ns	
t _{wP}	Write Pulse Width	40	-	50	-	ns	
t _{wR}	Write Recovery Time	0	-	0	-	ns	
t _{WHZ}	Write to Output in High Z	0	25	0	25	ns	
t _{dW}	Data to Write Time Overlap	25	-	30	-	ns	
t _{dH}	Data Hold from Write Time	0	-	0	-	ns	
t _{ow}	Output Active from End of Write	5	-	5	-	ns	

Notes: t_{CHZ1}, t_{CHZ2}, t_{OHZ} and t_{WHZ} are defined as the time at which the outputs achieve the open circuit condition and are not referred to output voltage levels.

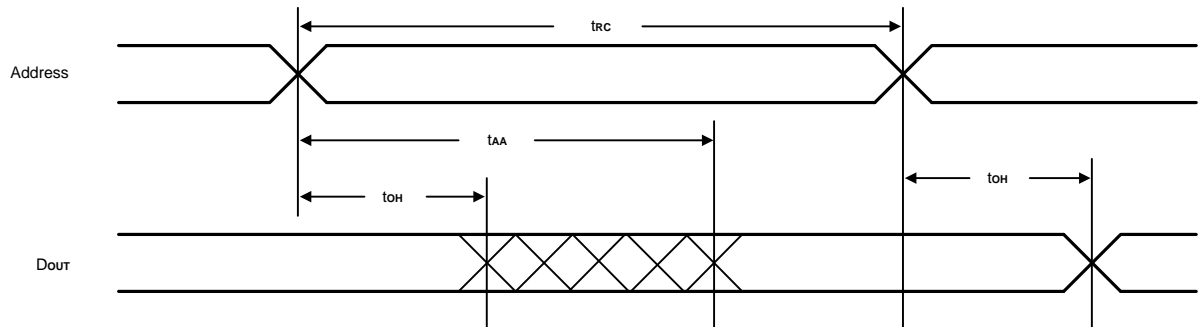
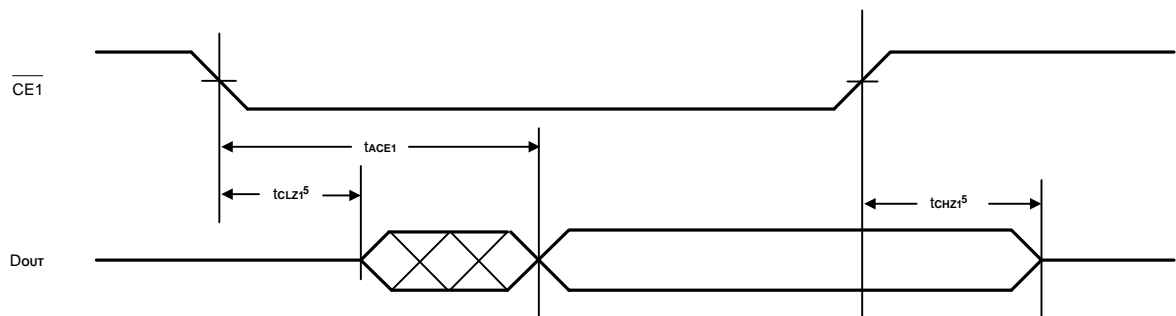
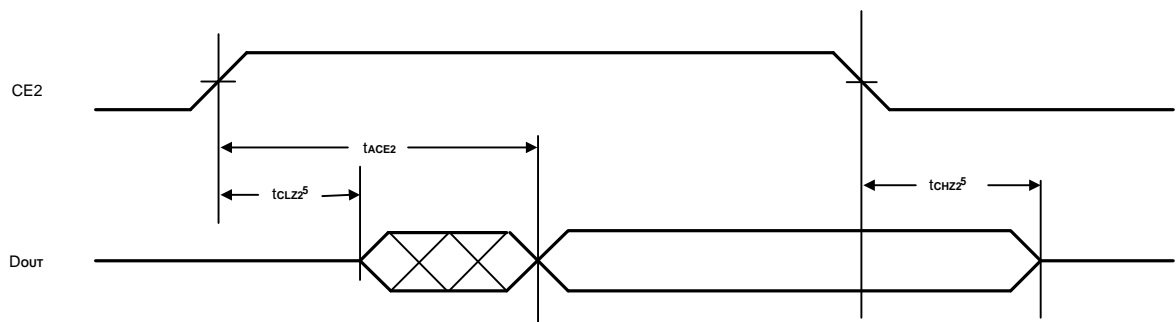
Timing Waveforms
Read Cycle 1 (1, 2, 4)

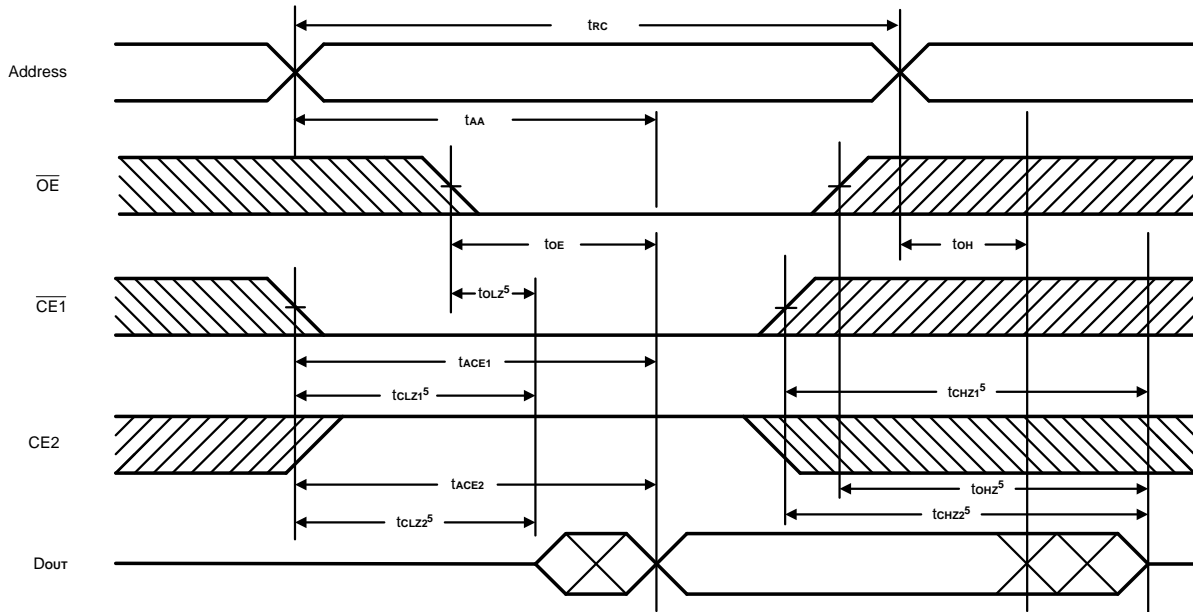
Read Cycle 2 (1, 3, 4, 6)

Read Cycle 3 (1, 4, 7, 8)

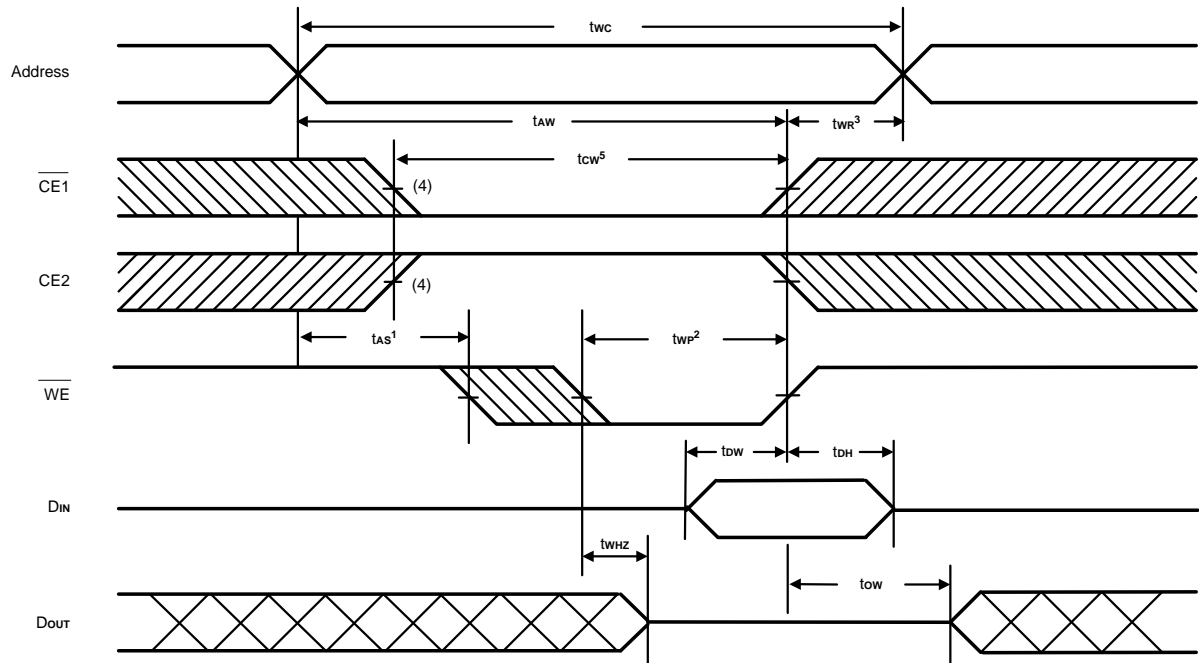
Timing Waveforms (continued)
Read Cycle 4 ⁽¹⁾

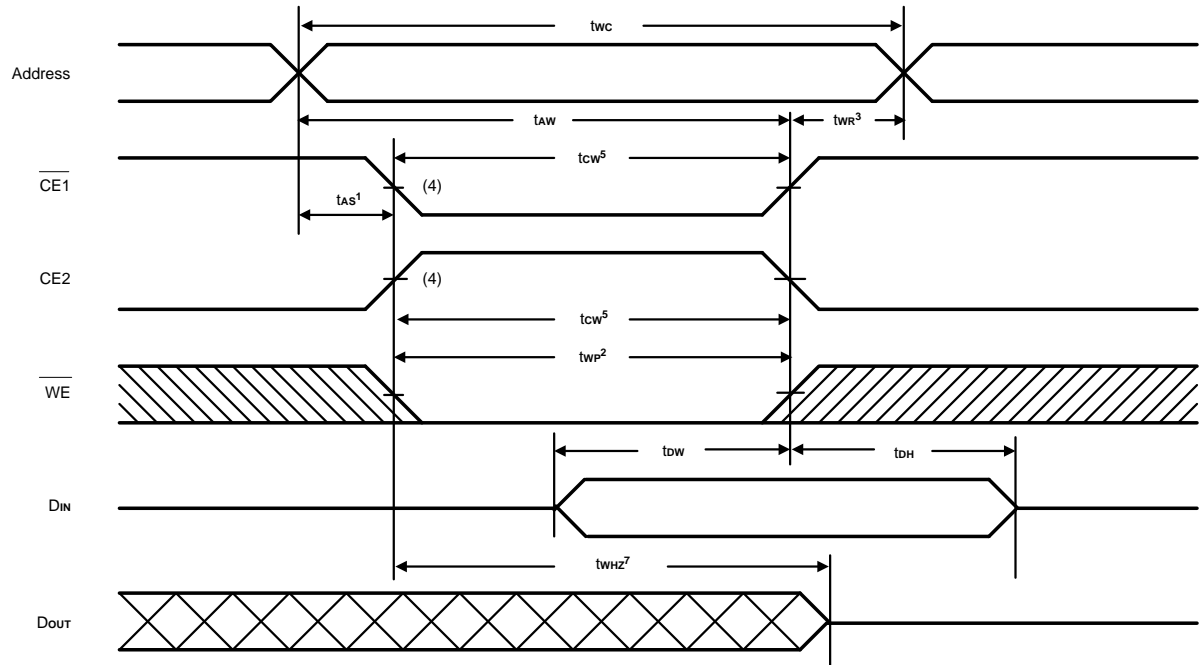
- Notes:
1. \overline{WE} is high for Read Cycle.
 2. Device is continuously enabled $\overline{CE1} = V_{IL}$ and $CE2 = V_{IH}$.
 3. Address valid prior to or coincident with $\overline{CE1}$ transition low.
 4. $\overline{OE} = V_{IL}$.
 5. Transition is measured $\pm 500\text{mV}$ from steady state. This parameter is sampled and not 100% tested.
 6. CE2 is high.
 7. $\overline{CE1}$ is low.
 8. Address valid prior to or coincident with CE2 transition high.

Timing Waveforms (continued)
**Write Cycle 1⁽⁶⁾
(Write Enable Controlled)**

Timing Waveforms (continued)
**Write Cycle 2
(Chip Enable Controlled)**

- Notes:
1. t_{As} is measured from the address valid to the beginning of Write.
 2. A Write occurs during the overlap (t_{wp}) of a low $\overline{CE1}$, a high CE2 and a low \overline{WE} .
 3. t_{wr}^3 is measured from the earliest of $\overline{CE1}$ or \overline{WE} going high or CE2 going low to the end of the Write cycle.
 4. If the $\overline{CE1}$ low transition or the CE2 high transition occurs simultaneously with the \overline{WE} low transition or after the \overline{WE} transition, outputs remain in a high impedance state.
 5. t_{cw}^5 is measured from the later of $\overline{CE1}$ going low or CE2 going high to the end of Write.
 6. \overline{OE} is continuously low. ($\overline{OE} = V_{IL}$)
 7. Transition is measured $\pm 500\text{mV}$ from steady state. This parameter is sampled and not 100% tested.

AC Test Conditions

Input Pulse Levels	0.4V to 2.4V
Input Rise and Fall Time	5 ns
Input and Output Timing Reference Levels	1.5V
Output Load	See Figures 1 and 2

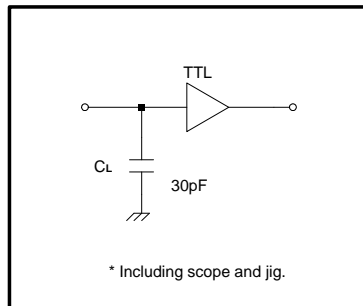
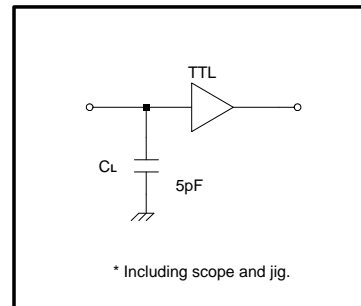
Figure 1. Output Load

Figure 2. Output Load for t_{CLZ1} , t_{CLZ2} , t_{OHZ} , t_{OLZ} , t_{CHZ1} , t_{CHZ2} , t_{WHZ} , and t_{OW}
Data Retention Characteristics ($T_A = 0^\circ\text{C}$ to $+70^\circ\text{C}$ or -40°C to $+85^\circ\text{C}$)

Symbol	Parameter	Min.	Max.	Unit	Conditions
V_{DR1}	VCC for Data Retention	2.0	3.6	V	$\overline{CE1} \geq VCC - 0.2V$
V_{DR2}		2.0	3.6	V	$CE2 \leq 0.2V$
I_{CCDR1}	Data Retention Current	-	1*	μA	$VCC = 2.0V$ $\overline{CE1} \geq VCC - 0.2V$ $V_{IN} \geq 0V$
I_{CCDR2}		-	1*	μA	$VCC = 2.0V$ $CE2 \leq 0.2V$ $V_{IN} \geq 0V$
t_{CDR}	Chip Disable to Data Retention Time	0	-	ns	See Retention Waveform
t_R	Operation Recovery Time	t_{RC}	-	ns	
t_{VR}	VCC Rise Time from Data Retention Voltage to Operating Voltage	5	-	ms	

* A62S6308A-55S/70S
A62S6308A-55SU/70SU

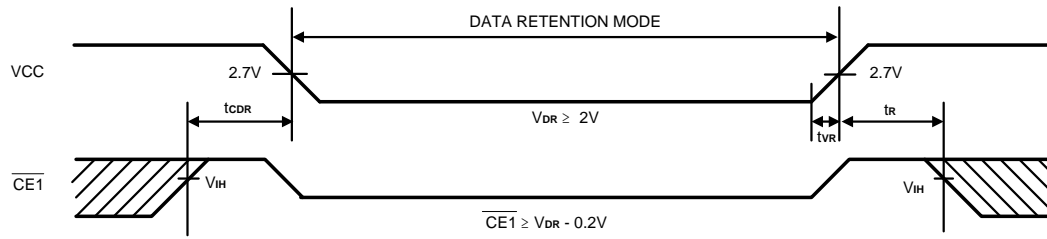
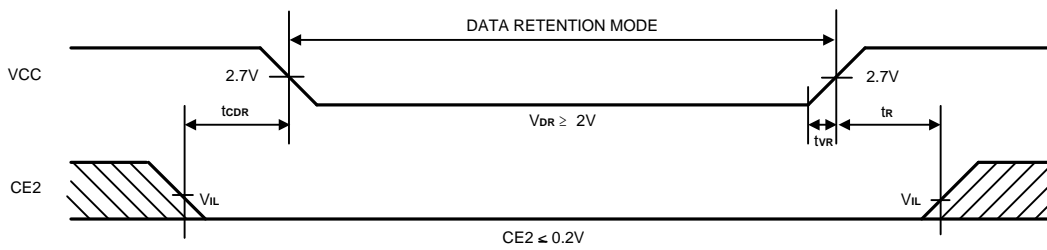
I_{CCDR} : Max. $1\mu\text{A}$ at $T_A = 0^\circ\text{C}$ to $+40^\circ\text{C}$
 I_{CCDR} : Max. $1\mu\text{A}$ at $T_A = 0^\circ\text{C}$ to $+40^\circ\text{C}$

Low VCC Data Retention Waveform (1) ($\overline{CE1}$ Controlled)

Low VCC Data Retention Waveform (2) (CE2 Controlled)

Ordering Information

Part No.	Access Time (ns)	Operating Current Max. (mA)	Standby Current Max. (μ A)	Package
A62S6308AM-55SF	55	30	5	32L Pb-Free SOP
A62S6308AM-55SUF				32L Pb-Free SOP
A62S6308AV-55SF				32L Pb-Free TSOP
A62S6308AV-55SUF				32L Pb-Free TSOP
A62S6308AX-55SF				32L Pb-Free sTSOP
A62S6308AX-55SUF				32L Pb-Free sTSOP
A62S6308AM-70SF	70	30	5	32L Pb-Free SOP
A62S6308AM-70SUF				32L Pb-Free SOP
A62S6308AV-70SF				32L Pb-Free TSOP
A62S6308AV-70SUF				32L Pb-Free TSOP
A62S6308AX-70SF				32L Pb-Free sTSOP
A62S6308AX-70SUF				32L Pb-Free sTSOP

Package Information
SOP (W.B.) 32L Outline Dimensions

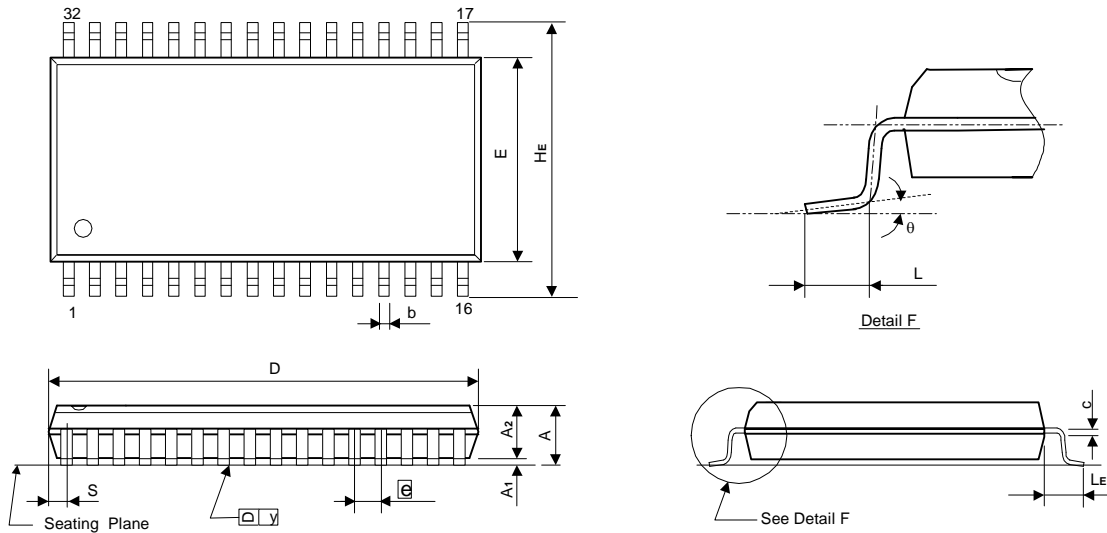
unit: inches/mm



Symbol	Dimensions in inches			Dimensions in mm		
	Min	Nom	Max	Min	Nom	Max
A	-	-	0.118	-	-	3.00
A1	0.004	-	-	0.10	-	-
A2	0.101	0.106	0.111	2.57	2.69	2.82
b	0.014	0.016	0.020	0.36	0.41	0.51
c	0.006	0.008	0.012	0.15	0.20	0.31
D	-	0.805	0.817	-	20.45	20.75
E	0.440	0.445	0.450	11.18	11.30	11.43
e	0.044	0.050	0.056	1.12	1.27	1.42
HE	0.546	0.556	0.566	13.87	14.12	14.38
L	0.023	0.031	0.039	0.58	0.79	0.99
LE	0.047	0.055	0.063	1.19	1.40	1.60
S	-	-	0.036	-	-	0.91
y	-	-	0.004	-	-	0.10
θ	0°	-	10°	0°	-	10°

Notes:

1. The maximum value of dimension D includes end flash.
2. Dimension E does not include resin fins.
3. Dimension S includes end flash.

Package Information
TSOP 32L TYPE I (8 X 20mm) Outline Dimensions

unit: inches/mm

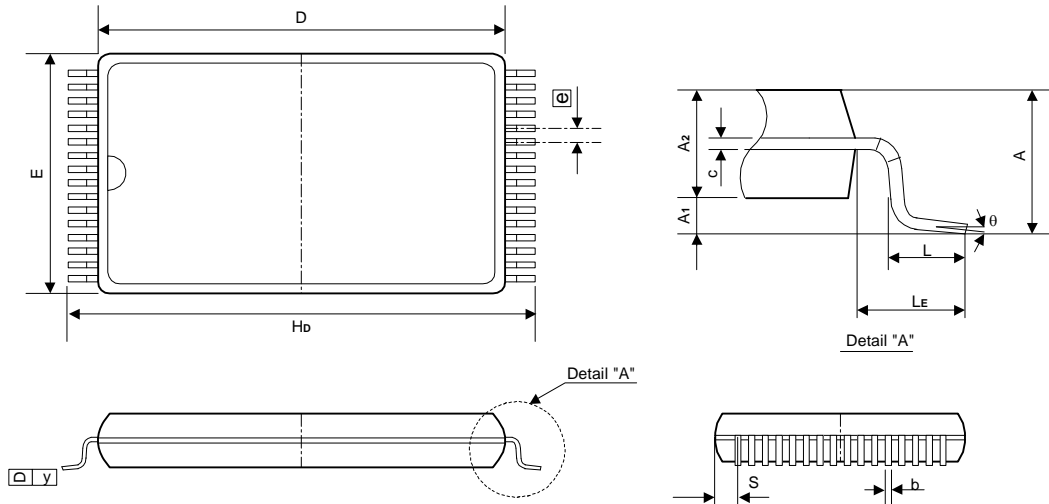

Symbol	Dimensions in inches			Dimensions in mm		
	Min	Nom	Max	Min	Nom	Max
A	-	-	0.047	-	-	1.20
A ₁	0.002	-	0.006	0.05	-	0.15
A ₂	0.037	0.039	0.041	0.95	1.00	1.05
b	0.007	0.009	0.011	0.18	0.22	0.27
c	0.004	-	0.008	0.11	-	0.20
D	0.720	0.724	0.728	18.30	18.40	18.50
E	-	0.315	0.319	-	8.00	8.10
e	0.020 BSC			0.50 BSC		
H _D	0.779	0.787	0.795	19.80	20.00	20.20
L	0.016	0.020	0.024	0.40	0.50	0.60
L _E	-	0.032	-	-	0.80	-
S	-	-	0.020	-	-	0.50
y	-	-	0.003	-	-	0.08
θ	0°	-	5°	0°	-	5°

Notes:

1. The maximum value of dimension D includes end flash.
2. Dimension E does not include resin fins.
3. Dimension S includes end flash.

Package Information
sTSOP 32L TYPE I (8 X 13.4mm) Outline Dimensions

unit: inches/mm

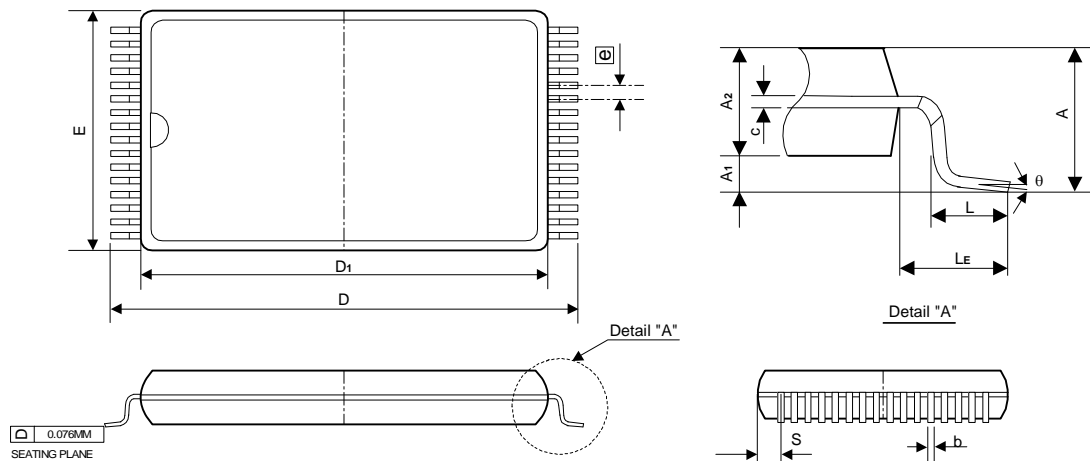

Symbol	Dimensions in inches			Dimensions in mm		
	Min	Nom	Max	Min	Nom	Max
A	-	-	0.049	-	-	1.25
A ₁	0.002	-	-	0.05	-	-
A ₂	0.037	0.039	0.041	0.95	1.00	1.05
b	0.007	0.008	0.009	0.17	0.20	0.23
c	0.0056	0.0059	0.0062	0.142	0.150	0.158
E	0.311	0.315	0.319	7.90	8.00	8.10
[e]	0.020 TYP			0.50 TYP		
D	0.520	0.528	0.535	13.20	13.40	13.60
D ₁	0.461	0.465	0.469	11.70	11.80	11.90
L	0.012	0.020	0.028	0.30	0.50	0.70
LE	0.0275	0.0315	0.0355	0.700	0.800	0.900
S	0.0109 TYP			0.278 TYP		
θ	0°	3°	5°	0°	3°	5°

Notes:

1. The maximum value of dimension D₁ includes end flash.
2. Dimension E does not include resin fins.
3. Dimension S includes end flash.