



A29L008 Series

1M X 8 Bit CMOS 3.0 Volt-only, Boot Sector Flash Memory

Document Title

1M X 8 Bit CMOS 3.0 Volt-only, Boot Sector Flash Memory

Revision History

<u>Rev. No.</u>	<u>History</u>	<u>Issue Date</u>	<u>Remark</u>
0.0	Initial issue	November 1, 2002	Preliminary
1.0	Final version release	October 7, 2003	Final
1.1	Add Pb-Free package type	August 20, 2004	
1.2	Page 1: Change from typical 100,000 cycles to minimum 100,000 cycles	January 24, 2011	



A29L008 Series

1M X 8 Bit CMOS 3.0 Volt-only, Boot Sector Flash Memory

Features

- Single power supply operation
 - Full voltage range: 2.7 to 3.6 volt read and write operations for battery-powered applications
- Access times:
 - 70/90 (max.)
- Current:
 - 9 mA typical active read current
 - 20 mA typical program/erase current
 - 200 nA typical CMOS standby
 - 200 nA Automatic Sleep Mode current
- Flexible sector architecture
 - 16 Kbyte/ 8 KbyteX2/ 32 Kbyte/ 64 KbyteX15 sectors
 - Any combination of sectors can be erased
 - Supports full chip erase
 - Sector protection:
 - A hardware method of protecting sectors to prevent any inadvertent program or erase operations within that sector. Temporary Sector Unprotect feature allows code changes in previously locked sectors
- Extended operating temperature range: -40°C ~ +85°C for -U series
- Unlock Bypass Program Command
 - Reduces overall programming time when issuing multiple program command sequence
- Top or bottom boot block configurations available
- Embedded Algorithms
 - Embedded Erase algorithm will automatically erase the entire chip or any combination of designated sectors and verify the erased sectors
 - Embedded Program algorithm automatically writes and verifies data at specified addresses
- Minimum 100,000 program/erase cycles per sector
- 20-year data retention at 125°C
 - Reliable operation for the life of the system
- Compatible with JEDEC-standards
 - Pinout and software compatible with single-power-supply Flash memory standard
 - Superior inadvertent write protection
- Data Polling and toggle bits
 - Provides a software method of detecting completion of program or erase operations
- Ready / $\overline{\text{BUSY}}$ pin (RY / $\overline{\text{BY}}$)
 - Provides a hardware method of detecting completion of program or erase operations
- Erase Suspend/Erase Resume
 - Suspends a sector erase operation to read data from, or program data to, a non-erasing sector, then resumes the erase operation
- Hardware reset pin ($\overline{\text{RESET}}$)
 - Hardware method to reset the device to reading array data
- Package options
 - 40-pin TSOP (I)

General Description

The A29L008 is an 8Mbit, 3.0 volt-only Flash memory organized as 1,048,576 bytes. The data appear on I/O₀ - I/O₇. The A29L008 is offered in 40-pin TSOP package. This device is designed to be programmed in-system with the standard system 3.0 volt VCC supply. Additional 12.0 volt VPP is not required for in-system write or erase operations. However, the A29L008 can also be programmed in standard EPROM programmers.

The A29L008 has the first toggle bit, I/O₆, which indicates whether an Embedded Program or Erase is in progress, or it is in the Erase Suspend. Besides the I/O₆ toggle bit, the A29L008 has a second toggle bit, I/O₂, to indicate whether the addressed sector is being selected for erase. The A29L008 also offers the ability to program in the Erase Suspend mode. The standard A29L008 offers access times of 70 and 90ns, allowing high-speed microprocessors to operate without wait states. To eliminate bus contention the device has separate chip enable ($\overline{\text{CE}}$), write enable ($\overline{\text{WE}}$) and output enable ($\overline{\text{OE}}$) controls.

The device requires only a single 3.0 volt power supply for both read and write functions. Internally generated and regulated voltages are provided for the program and erase operations.

The A29L008 is entirely software command set compatible with the JEDEC single-power-supply Flash standard.

Commands are written to the command register using standard microprocessor write timings. Register contents serve as input to an internal state-machine that controls the erase and programming circuitry. Write cycles also internally latch addresses and data needed for the programming and erase operations. Reading data out of the device is similar to reading from other Flash or EPROM devices.

Device programming occurs by writing the proper program command sequence. This initiates the Embedded Program algorithm - an internal algorithm that automatically times the program pulse widths and verifies proper program margin.

Device erasure occurs by executing the proper erase command sequence. This initiates the Embedded Erase algorithm - an internal algorithm that automatically preprograms the array (if it is not already programmed) before executing the erase operation. During erase, the device automatically times the erase pulse widths and verifies proper erase margin. The Unlock Bypass mode facilitates faster programming times by requiring only two write cycles to program data instead of four.

The host system can detect whether a program or erase operation is complete by observing the RY / $\overline{\text{BY}}$ pin, or by reading the I/O₇ (Data Polling) and I/O₆ (toggle) status bits. After a program or erase cycle has been completed, the

device is ready to read array data or accept another command.

The sector erase architecture allows memory sectors to be erased and reprogrammed without affecting the data contents of other sectors. The A29L008 is fully erased when shipped from the factory.

The hardware sector protection feature disables operations for both program and erase in any combination of the sectors of memory. This can be achieved via programming equipment.

The Erase Suspend/Erase Resume feature enables the user to put erase on hold for any period of time to read data from, or program data to, any other sector that is not selected for erasure. True background erase can thus be achieved.

The hardware $\overline{\text{RESET}}$ pin terminates any operation in progress and resets the internal state machine to reading array data. The $\overline{\text{RESET}}$ pin may be tied to the system reset circuitry. A system reset would thus also reset the device, enabling the system microprocessor to read the boot-up firmware from the Flash memory.

The device offers two power-saving features. When addresses have been stable for a specified amount of time, the device enters the automatic sleep mode. The system can also place the device into the standby mode. Power consumption is greatly reduced in both these modes.

Pin Configurations

■ TSOP (I)

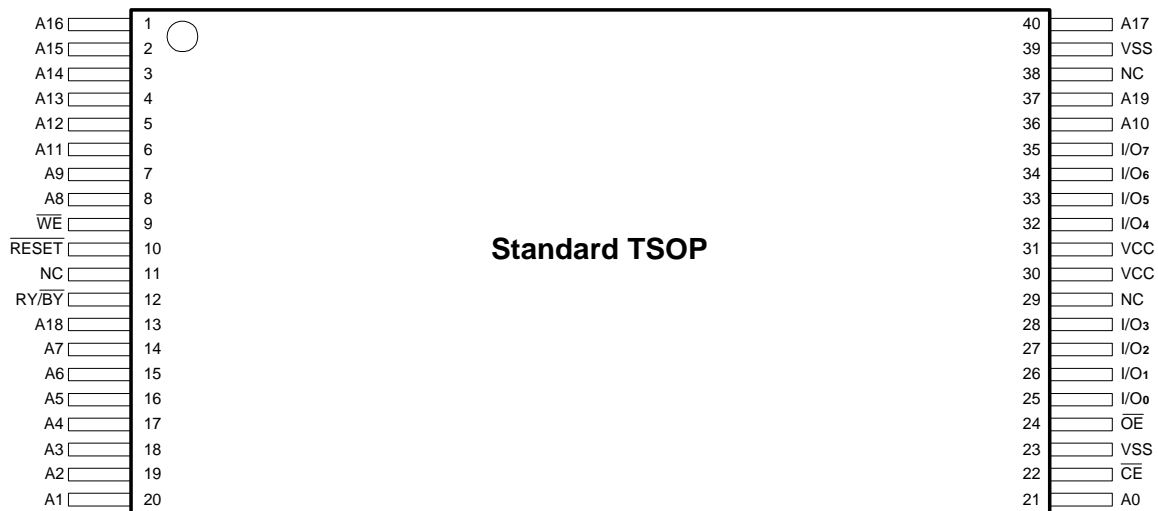

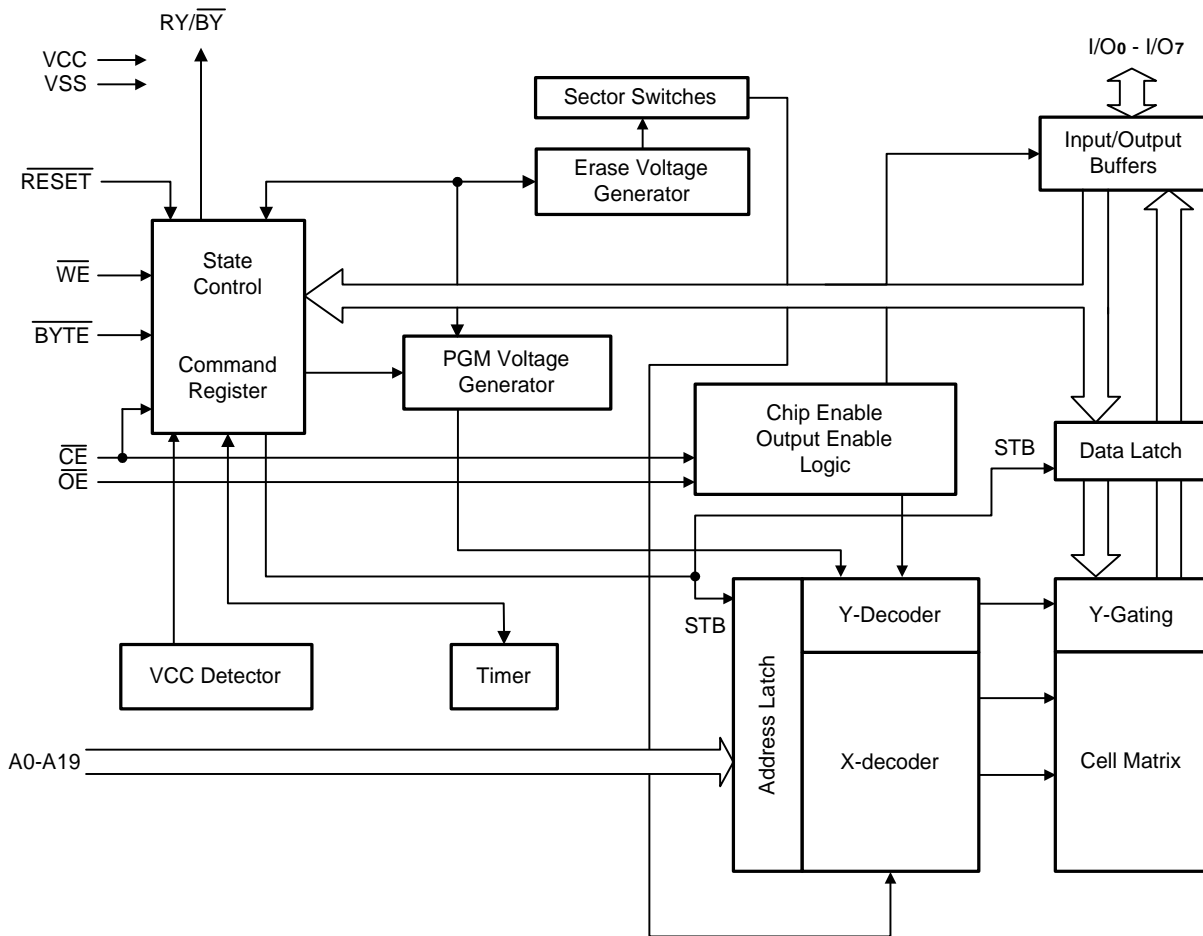
Block Diagram

Pin Descriptions

Pin No.	Description
A0 - A19	Address Inputs
I/O ₀ - I/O ₇	Data Inputs/Outputs
\overline{CE}	Chip Enable
\overline{WE}	Write Enable
\overline{OE}	Output Enable
\overline{RESET}	Hardware Reset
\overline{BYTE}	Selects Byte Mode or Word Mode
RY/ \overline{BY}	Ready/ \overline{BUSY} - Output
VSS	Ground
VCC	Power Supply
NC	Pin not connected internally

Absolute Maximum Ratings*

Storage Temperature Plastic Packages 0°C to + 70°C
 for -U series: -40°C to +85°C
 Ambient Temperature with Power Applied . . . 0°C to + 70°C
 for -U series: -40°C to +85°C
 Voltage with Respect to Ground
 VCC (Note 1) -0.5V to +4.0V
 A9, \overline{OE} & \overline{RESET} (Note 2) -0.5 to +12.5V
 All other pins (Note 1) -0.5V to VCC + 0.5V
 Output Short Circuit Current (Note 3) 200mA

Notes:

1. Minimum DC voltage on input or I/O pins is -0.5V. During voltage transitions, input or I/O pins may undershoot VSS to -2.0V for periods of up to 20ns. Maximum DC voltage on input and I/O pins is VCC +0.5V. During voltage transitions, input or I/O pins may overshoot to VCC +2.0V for periods up to 20ns.
2. Minimum DC input voltage on A9, \overline{OE} and \overline{RESET} is -0.5V. During voltage transitions, A9, \overline{OE} and \overline{RESET} may overshoot VSS to -2.0V for periods of up to 20ns. Maximum DC input voltage on A9 is +12.5V which may overshoot to 14.0V for periods up to 20ns.
3. No more than one output is shorted at a time. Duration of the short circuit should not be greater than one second.

Device Bus Operations

This section describes the requirements and use of the device bus operations, which are initiated through the internal command register. The command register itself does not occupy any addressable memory location. The register is composed of latches that store the commands, along with the address and data information needed to execute the

***Comments**

Stresses above those listed under "Absolute Maximum Ratings" may cause permanent damage to this device. These are stress ratings only. Functional operation of this device at these or any other conditions above those indicated in the operational sections of these specification is not implied or intended. Exposure to the absolute maximum rating conditions for extended periods may affect device reliability.

Operating Ranges
Commercial (C) Devices

Ambient Temperature (TA) 0°C to +70°C

Extended Range Devices

Ambient Temperature (TA) -40°C to +85°C

VCC Supply Voltages

VCC for all devices +2.7V to +3.6V
 Operating ranges define those limits between which the functionality of the device is guaranteed.

command. The contents of the register serve as inputs to the internal state machine. The state machine outputs dictate the function of the device. The appropriate device bus operations table lists the inputs and control levels required, and the resulting output. The following subsections describe each of these operations in further detail.

Table 1. A29L008 Device Bus Operations

Operation	\overline{CE}	\overline{OE}	\overline{WE}	\overline{RESET}	A0 – A19 (Note 1)	I/O ₀ - I/O ₇
Read	L	L	H	H	A _{IN}	D _{OUT}
Write	L	H	L	H	A _{IN}	D _{IN}
CMOS Standby	VCC ± 0.3 V	X	X	VCC ± 0.3 V	X	High-Z
Output Disable	L	H	H	H	X	High-Z
Hardware Reset	X	X	X	L	X	High-Z
Sector Protect (See Note 2)	L	H	L	V _{ID}	Sector Address, A ₆ =L, A ₁ =H, A ₀ =L	D _{IN} , D _{OUT}
Sector Unprotect (See Note 2)	L	H	L	V _{ID}	Sector Address, A ₆ =H, A ₁ =H, A ₀ =L	D _{IN} , D _{OUT}
Temporary Sector Unprotect	X	X	X	V _{ID}	A _{IN}	D _{IN}

Legend:

L = Logic Low = V_{IL}, H = Logic High = V_{IH}, V_{ID} = 12.0 ± 0.5V, X = Don't Care, D_{IN} = Data In, D_{OUT} = Data Out, A_{IN} = Address In

Notes:

1. Addresses are A19-A0 in word mode ($\overline{BYTE}=V_{IH}$), A18: A₁ in byte mode ($\overline{BYTE}=V_{IL}$).

2. See the "Sector Protection/Unprotection" section and Temporary Sector Unprotect for more information.

Requirements for Reading Array Data

To read array data from the outputs, the system must drive the \overline{CE} and \overline{OE} pins to V_{IL} . \overline{CE} is the power control and selects the device. \overline{OE} is the output control and gates array data to the output pins. \overline{WE} should remain at V_{IH} all the time during read operation. The internal state machine is set for reading array data upon device power-up, or after a hardware reset. This ensures that no spurious alteration of the memory content occurs during the power transition. No command is necessary in this mode to obtain array data. Standard microprocessor read cycles that assert valid addresses on the device address inputs produce valid data on the device data outputs. The device remains enabled for read access until the command register contents are altered. See "Reading Array Data" for more information. Refer to the AC Read Operations table for timing specifications and to the Read Operations Timings diagram for the timing waveforms, I_{CC1} in the DC Characteristics table represents the active current specification for reading array data.

Writing Commands/Command Sequences

To write a command or command sequence (which includes programming data to the device and erasing sectors of memory), the system must drive \overline{WE} and \overline{CE} to V_{IL} , and \overline{OE} to V_{IH} . The device features an Unlock Bypass mode to facilitate faster programming. Once the device enters the Unlock Bypass mode, only two write cycles are required to program a word or byte, instead of four. The "Program Command Sequence" section has details on programming data to the device using both standard and Unlock Bypass command sequence. An erase operation can erase one sector, multiple sectors, or the entire device. The Sector Address Tables indicate the address range that each sector occupies. A "sector address" consists of the address inputs required to uniquely select a sector. See the "Command Definitions" section for details on erasing a sector or the entire chip, or suspending/resuming the erase operation.

After the system writes the autoselect command sequence, the device enters the autoselect mode. The system can then read autoselect codes from the internal register (which is separate from the memory array) on $I/O_7 - I/O_0$. Standard read cycle timings apply in this mode. Refer to the "Autoselect Mode" and "Autoselect Command Sequence" sections for more information.

I_{CC2} in the DC Characteristics table represents the active current specification for the write mode. The "AC Characteristics" section contains timing specification tables and timing diagrams for write operations.

Program and Erase Operation Status

During an erase or program operation, the system may check the status of the operation by reading the status bits on $I/O_7 - I/O_0$. Standard read cycle timings and I_{CC} read specifications apply. Refer to "Write Operation Status" for more information, and to each AC Characteristics section for timing diagrams.

Standby Mode

When the system is not reading or writing to the device, it can place the device in the standby mode. In this mode, current consumption is greatly reduced, and the outputs are placed in the high impedance state, independent of the \overline{OE} input.

The device enters the CMOS standby mode when the \overline{CE} & \overline{RESET} pins are both held at $V_{CC} \pm 0.3V$. (Note that this is a more restricted voltage range than V_{IH} .) If \overline{CE} and \overline{RESET} are held at V_{IH} , but not within $V_{CC} \pm 0.3V$, the device will be in the standby mode, but the standby current will be greater. The device requires the standard access time (t_{CE}) before it is ready to read data.

If the device is deselected during erasure or programming, the device draws active current until the operation is completed.

I_{CC3} and I_{CC4} in the DC Characteristics tables represent the standby current specification.

Automatic Sleep Mode

The automatic sleep mode minimizes Flash device energy consumption. The device automatically enables this mode when addresses remain stable for $t_{ACC} + 30ns$. The automatic sleep mode is independent of the \overline{CE} , \overline{WE} and \overline{OE} control signals. Standard address access timings provide new data when addresses are changed. While in sleep mode, output data is latched and always available to the system. I_{CC4} in the DC Characteristics table represents the automatic sleep mode current specification.

Output Disable Mode

When the \overline{OE} input is at V_{IH} , output from the device is disabled. The output pins are placed in the high impedance state.

RESET : Hardware Reset Pin

The \overline{RESET} pin provides a hardware method of resetting the device to reading array data. When the system drives the \overline{RESET} pin low for at least a period of t_{RP} , the device immediately terminates any operation in progress, tristates all data output pins, and ignores all read/write attempts for the duration of the \overline{RESET} pulse. The device also resets the internal state machine to reading array data. The operation that was interrupted should be reinitiated once the device is ready to accept another command sequence, to ensure data integrity.

Current is reduced for the duration of the \overline{RESET} pulse. When \overline{RESET} is held at $V_{SS} \pm 0.3V$, the device draws CMOS standby current (I_{CC4}). If \overline{RESET} is held at V_{IL} but not within $V_{SS} \pm 0.3V$, the standby current will be greater.

The \overline{RESET} pin may be tied to the system reset circuitry. A system reset would thus also reset the Flash memory, enabling the system to read the boot-up firmware from the Flash memory.

If \overline{RESET} is asserted during a program or erase operation, the $\overline{RY}/\overline{BY}$ pin remains a "0" (busy) until the internal reset operation is complete, which requires a time t_{READY} (during Embedded Algorithms). The system can thus monitor $\overline{RY}/\overline{BY}$ to determine whether the reset operation is complete. If \overline{RESET} is asserted when a program or erase operation is not executing ($\overline{RY}/\overline{BY}$ pin is "1"), the reset operation is completed within a time of t_{READY} (not during Embedded Algorithms). The system can read data t_{RH} after the \overline{RESET} pin return to V_{IH} .

Refer to the AC Characteristics tables for \overline{RESET} parameters and diagram.

Table 2. A29L008 Top Boot Block Sector Address Table

Sector	A19	A18	A17	A16	A15	A14	A13	Sector Size (Kbytes)	Address Range (in hexadecimal)
SA0	0	0	0	0	X	X	X	64	0000h - 0FFFFh
SA1	0	0	0	1	X	X	X	64	1000h - 1FFFFh
SA2	0	0	1	0	X	X	X	64	2000h - 2FFFFh
SA3	0	0	1	1	X	X	X	64	3000h - 3FFFFh
SA4	0	1	0	0	X	X	X	64	4000h - 4FFFFh
SA5	0	1	0	1	X	X	X	64	5000h - 5FFFFh
SA6	0	1	1	0	X	X	X	64	6000h - 6FFFFh
SA7	0	1	1	1	X	X	X	64	7000h - 7FFFFh
SA8	1	0	0	0	X	X	X	64	8000h - 8FFFFh
SA9	1	0	0	1	X	X	X	64	9000h - 9FFFFh
SA10	1	0	1	0	X	X	X	64	A000h - AFFFFh
SA11	1	0	1	1	X	X	X	64	B000h - BFFFFh
SA12	1	1	0	0	X	X	X	64	C000h - CFFFFh
SA13	1	1	0	1	X	X	X	64	D000h - DFFFFh
SA14	1	1	1	0	X	X	X	64	E000h - EFFFFh
SA15	1	1	1	1	0	X	X	32	F000h - F7FFFh
SA16	1	1	1	1	1	0	0	8	F800h - F9FFFh
SA17	1	1	1	1	1	0	1	8	FA00h - F8FFFh
SA18	1	1	1	1	1	1	X	16	FC00h - FFFFFh

Table 3. A29L008 Bottom Boot Block Sector Address Table

Sector	A19	A18	A17	A16	A15	A14	A13	Sector Size (Kbytes)	Address Range (in hexadecimal)
SA0	0	0	0	0	0	0	X	16	0000h - 03FFFh
SA1	0	0	0	0	0	1	0	8	0400h - 05FFFh
SA2	0	0	0	0	0	1	1	8	0600h - 07FFFh
SA3	0	0	0	0	1	X	X	32	0800h - 0FFFFh
SA4	0	0	0	1	X	X	X	64	1000h - 1FFFFh
SA5	0	0	1	0	X	X	X	64	2000h - 2FFFFh
SA6	0	0	1	1	X	X	X	64	3000h - 3FFFFh
SA7	0	1	0	0	X	X	X	64	4000h - 4FFFFh
SA8	0	1	0	1	X	X	X	64	5000h - 5FFFFh
SA9	0	1	1	0	X	X	X	64	6000h - 6FFFFh
SA10	0	1	1	1	X	X	X	64	7000h - 7FFFFh
SA11	1	0	0	0	X	X	X	64	8000h - 8FFFFh
SA12	1	0	0	1	X	X	X	64	9000h - 9FFFFh
SA13	1	0	1	0	X	X	X	64	A000h - AFFFFh
SA14	1	0	1	1	X	X	X	64	B000h - BFFFFh
SA15	1	1	0	0	X	X	X	64	C000h - CFFFFh
SA16	1	1	0	1	X	X	X	64	D000h - DFFFFh
SA17	1	1	1	0	X	X	X	64	E000h - EFFFFh
SA18	1	1	1	1	X	X	X	64	F000h - FFFFFh

Autoselect Mode

The autoselect mode provides manufacturer and device identification, and sector protection verification, through identifier codes output on I/O₇ - I/O₀. This mode is primarily intended for programming equipment to automatically match a device to be programmed with its corresponding programming algorithm. However, the autoselect codes can also be accessed in-system through the command register. When using programming equipment, the autoselect mode requires V_{DD} (11.5V to 12.5 V) on address pin A9. Address pins A6, A1, and A0 must be as shown in Autoselect Codes (High Voltage Method) table. In addition, when verifying sector protection, the sector address must appear on the

appropriate highest order address bits. Refer to the corresponding Sector Address Tables. The Command Definitions table shows the remaining address bits that are don't care. When all necessary bits have been set as required, the programming equipment may then read the corresponding identifier code on I/O₇ - I/O₀. To access the autoselect codes in-system, the host system can issue the autoselect command via the command register, as shown in the Command Definitions table. This method does not require V_{DD}. See "Command Definitions" for details on using the autoselect mode.

Table 4. A29L008 Autoselect Codes (High Voltage Method)

Description	\overline{CE}	\overline{OE}	\overline{WE}	A19 to A13	A12 to A10	A9	A8 to A7	A6	A5 to A2	A1	A0	I/O ₇ to I/O ₀
Manufacturer ID: AMIC	L	L	H	X	X	V _{DD}	X	L	X	L	L	37h
Device ID: A29L008 (Top Boot Block)	L	L	H	X	X	V _{DD}	X	L	X	L	H	1Ah
Device ID: A29L008 (Bottom Boot Block)	L	L	H	X	X	V _{DD}	X	L	X	L	H	9Bh
Continuation ID	L	L	H	X	X	V _{DD}	X	L	X	H	H	7Fh
Sector Protection Verification	L	L	H	SA	X	V _{DD}	X	L	X	H	L	01h (protected)
												00h (unprotected)

L=Logic Low= V_{IL}, H=Logic High=V_{IH}, SA=Sector Address, X=Don't Care.

Note: The autoselect codes may also be accessed in-system via command sequences.

Sector Protection/Unprotection

The hardware sector protection feature disables both program and erase operations in any sector. The hardware sector unprotection feature re-enables both program and erase operations in previously protected sectors.

It is possible to determine whether a sector is protected or unprotected. See "Autoselect Mode" for details.

Sector protection / unprotection can be implemented via two methods. The primary method requires VID on the $\overline{\text{RESET}}$ pin only, and can be implemented either in-system or via programming equipment. Figure 2 shows the algorithm and the Sector Protect / Unprotect Timing Diagram illustrates the timing waveforms for this feature. This method uses standard microprocessor bus cycle timing. For sector unprotect, all unprotected sectors must first be protected prior to the first sector unprotect write cycle. The alternate method must be implemented using programming equipment. The procedure requires a high voltage (V_{ID}) on address pin A9 and the control pins.

The device is shipped with all sectors unprotected.

It is possible to determine whether a sector is protected or unprotected. See "Autoselect Mode" for details.

Hardware Data Protection

The requirement of command unlocking sequence for programming or erasing provides data protection against inadvertent writes (refer to the Command Definitions table). In addition, the following hardware data protection measures prevent accidental erasure or programming, which might otherwise be caused by spurious system level signals during V_{CC} power-up transitions, or from system noise. The device is powered up to read array data to avoid accidentally writing data to the array.

Write Pulse "Glitch" Protection

Noise pulses of less than 5ns (typical) on $\overline{\text{OE}}$, $\overline{\text{CE}}$ or $\overline{\text{WE}}$ do not initiate a write cycle.

Logical Inhibit

Write cycles are inhibited by holding any one of $\overline{\text{OE}} = V_{IL}$, $\overline{\text{CE}} = V_{IH}$ or $\overline{\text{WE}} = V_{IH}$. To initiate a write cycle, $\overline{\text{CE}}$ and $\overline{\text{WE}}$ must be a logical zero while $\overline{\text{OE}}$ is a logical one.

Power-Up Write Inhibit

If $\overline{\text{WE}} = \overline{\text{CE}} = V_{IL}$ and $\overline{\text{OE}} = V_{IH}$ during power up, the device does not accept commands on the rising edge of $\overline{\text{WE}}$. The internal state machine is automatically reset to reading array data on the initial power-up.

Temporary Sector Unprotect

This feature allows temporary unprotection of previous protected sectors to change data in-system. The Sector Unprotect mode is activated by setting the $\overline{\text{RESET}}$ pin to V_{ID} . During this mode, formerly protected sectors can be programmed or erased by selecting the sector addresses. Once V_{ID} is removed from the $\overline{\text{RESET}}$ pin, all the previously protected sectors are protected again. Figure 1 shows the algorithm, and the Temporary Sector Unprotect diagram shows the timing waveforms, for this feature.

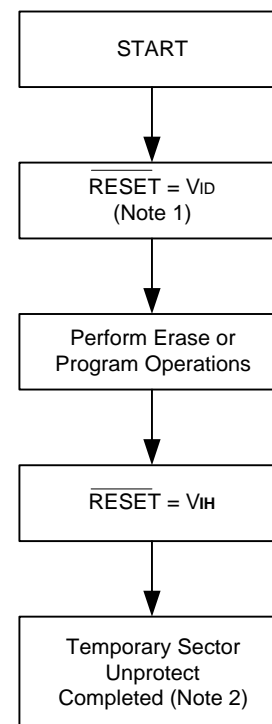

Notes:

1. All protected sectors unprotected.
2. All previously protected sectors are protected once again.

Figure 1. Temporary Sector Unprotect Operation

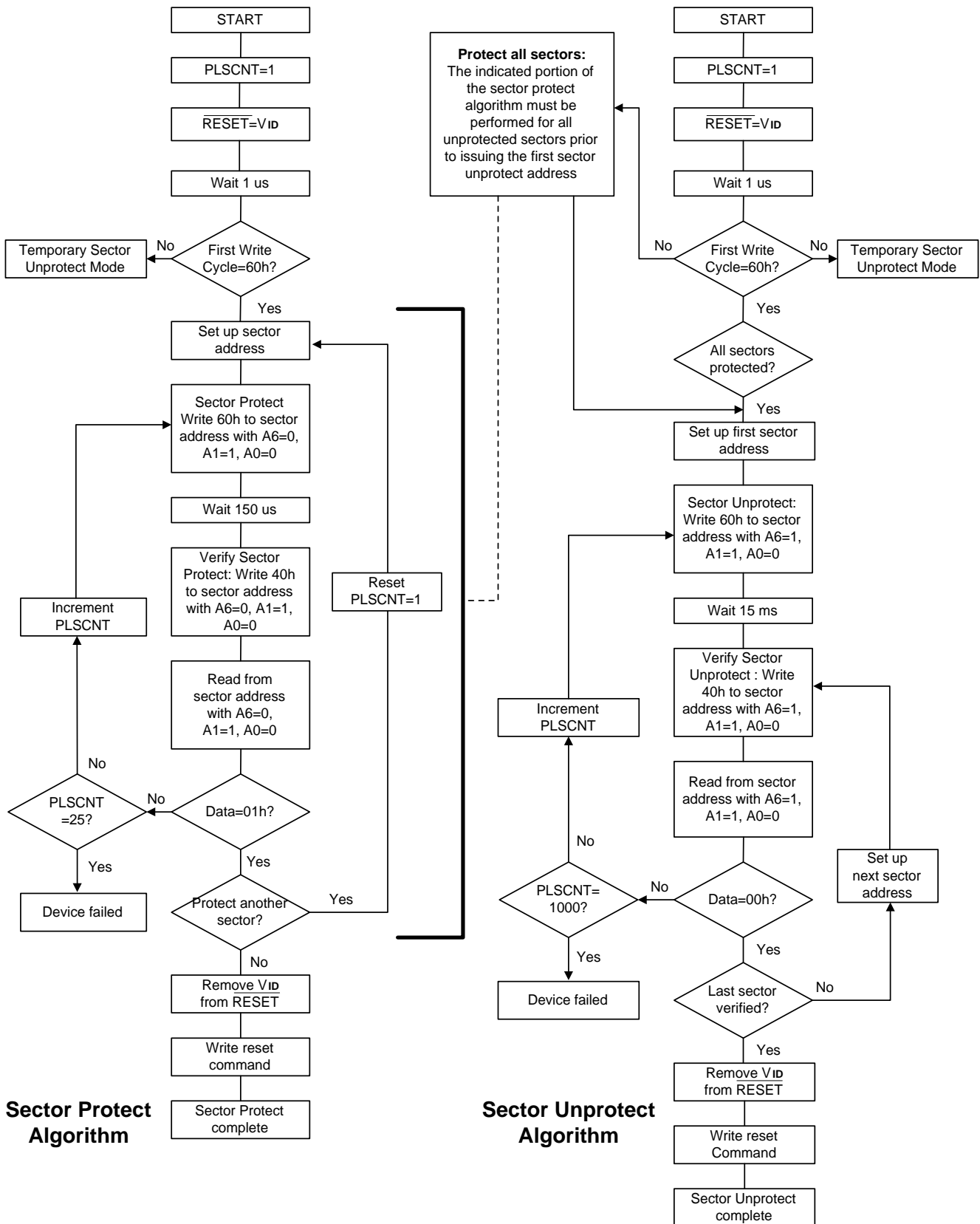
Figure 2. In-System Sector Protect/Unprotect Algorithms

Command Definitions

Writing specific address and data commands or sequences into the command register initiates device operations. The Command Definitions table defines the valid register command sequences. Writing incorrect address and data values or writing them in the improper sequence resets the device to reading array data.

All addresses are latched on the falling edge of \overline{WE} or \overline{CE} , whichever happens later. All data is latched on the rising edge of WE or CE , whichever happens first. Refer to the appropriate timing diagrams in the "AC Characteristics" section.

Reading Array Data

The device is automatically set to reading array data after device power-up. No commands are required to retrieve data. The device is also ready to read array data after completing an Embedded Program or Embedded Erase algorithm. After the device accepts an Erase Suspend command, the device enters the Erase Suspend mode. The system can read array data using the standard read timings, except that if it reads at an address within erase-suspended sectors, the device outputs status data. After completing a programming operation in the Erase Suspend mode, the system may once again read array data with the same exception. See "Erase Suspend/Erase Resume Commands" for more information on this mode.

The system must issue the reset command to re-enable the device for reading array data if I/O_5 goes high, or while in the autoselect mode. See the "Reset Command" section, next. See also "Requirements for Reading Array Data" in the "Device Bus Operations" section for more information. The Read Operations table provides the read parameters, and Read Operation Timings diagram shows the timing diagram.

Reset Command

Writing the reset command to the device resets the device to reading array data. Address bits are don't care for this command. The reset command may be written between the sequence cycles in an erase command sequence before erasing begins. This resets the device to reading array data. Once erasure begins, however, the device ignores reset commands until the operation is complete.

The reset command may be written between the sequence cycles in a program command sequence before programming begins. This resets the device to reading array data (also applies to programming in Erase Suspend mode). Once programming begins, however, the device ignores reset commands until the operation is complete.

The reset command may be written between the sequence cycles in an autoselect command sequence. Once in the autoselect mode, the reset command must be written to return to reading array data (also applies to autoselect during Erase Suspend).

If I/O_5 goes high during a program or erase operation, writing the reset command returns the device to reading array data (also applies during Erase Suspend).

Autoselect Command Sequence

The autoselect command sequence allows the host system to access the manufacturer and device codes, and determine whether or not a sector is protected. The Command Definitions table shows the address and data requirements. This method is an alternative to that shown in the Autoselect Codes (High Voltage Method) table, which is intended for PROM programmers and requires V_{DD} on address bit A9.

The autoselect command sequence is initiated by writing two unlock cycles, followed by the autoselect command. The device then enters the autoselect mode, and the system may read at any address any number of times, without initiating another command sequence.

A read cycle at address XX00h retrieves the manufacturer code and another read cycle at XX03h retrieves the continuation code. A read cycle at address XX01h returns the device code. A read cycle containing a sector address (SA) and the address 02h in returns 01h if that sector is protected, or 00h if it is unprotected. Refer to the Sector Address tables for valid sector addresses.

The system must write the reset command to exit the autoselect mode and return to reading array data.

Byte Program Command Sequence

Programming is a four-bus-cycle operation. The program command sequence is initiated by writing two unlock write cycles, followed by the program set-up command. The program address and data are written next, which in turn initiate the Embedded Program algorithm. The system is not required to provide further controls or timings. The device automatically provides internally generated program pulses and verify the programmed cell margin. Table 5 shows the address and data requirements for the byte program command sequence.

When the Embedded Program algorithm is complete, the device then returns to reading array data and addresses are longer latched. The system can determine the status of the program operation by using I/O_7 , I/O_6 , or RY/BY. See "Write Operation Status" for information on these status bits.

Any commands written to the device during the Embedded Program Algorithm are ignored. Note that a hardware reset immediately terminates the programming operation. The Byte Program command sequence should be reinitiated once the device has reset to reading array data, to ensure data integrity.

Programming is allowed in any sequence and across sector boundaries. A bit cannot be programmed from a "0" back to a "1". Attempting to do so may halt the operation and set I/O_5 to "1", or cause the \overline{Data} Polling algorithm to indicate the operation was successful. However, a succeeding read will show that the data is still "0". Only erase operations can convert a "0" to a "1".

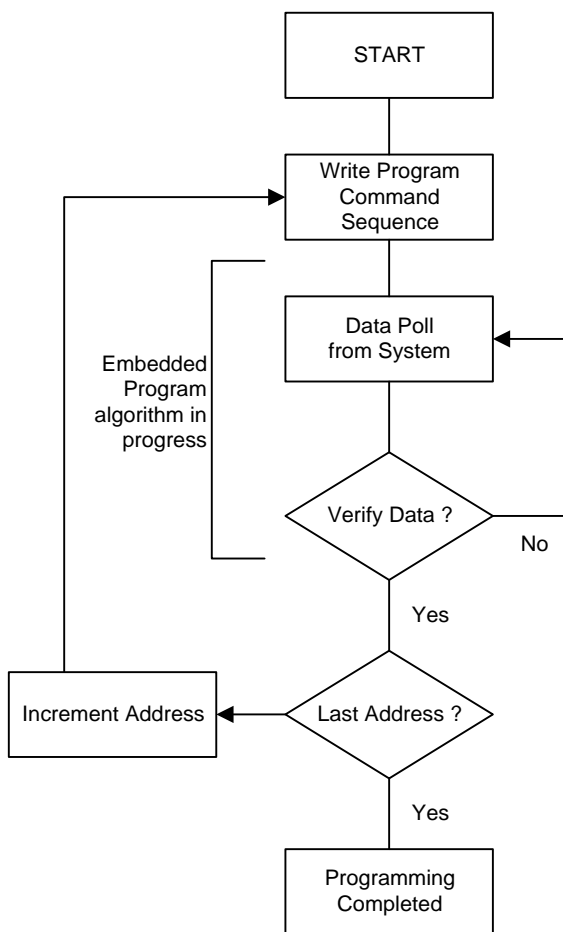

Note : See the appropriate Command Definitions table for program command sequence.

Figure 3. Program Operation

Unlock Bypass Command Sequence

The unlock bypass feature allows the system to program bytes or words to the device faster than using the standard program command sequence. The unlock bypass command sequence is initiated by first writing two unlock cycles. This is followed by a third write cycle containing the unlock bypass command, 20h. The device then enters the unlock bypass mode. A two-cycle unlock bypass program command sequence is all that is required to program in this mode. The first cycle in this sequence contains the unlock bypass program command, A0h; the second cycle contains the program address and data. Additional data is programmed in the same manner. This mode dispenses with the initial two unlock cycles required in the standard program command sequence, resulting in faster total programming time. Table 5 shows the requirements for the command sequence.

During the unlock bypass mode, only the Unlock Bypass Program and Unlock Bypass Reset commands are valid. To exit the unlock bypass mode, the system must issue the two-cycle unlock bypass reset command sequence. The first cycle must contain the data 90h; the second cycle the data

00h. Addresses are don't care for both cycle. The device returns to reading array data.

Figure 3 illustrates the algorithm for the program operation. See the Erase/Program Operations in "AC Characteristics" for parameters, and to Program Operation Timings for timing diagrams.

Chip Erase Command Sequence

Chip erase is a six-bus-cycle operation. The chip erase command sequence is initiated by writing two unlock cycles, followed by a set-up command. Two additional unlock write cycles are then followed by the chip erase command, which in turn invokes the Embedded Erase algorithm. The device does not require the system to preprogram prior to erase. The Embedded Erase algorithm automatically preprograms and verifies the entire memory for an all zero data pattern prior to electrical erase. The system is not required to provide any controls or timings during these operations. The Command Definitions table shows the address and data requirements for the chip erase command sequence.

Any commands written to the chip during the Embedded Erase algorithm are ignored. The system can determine the status of the erase operation by using I/O7, I/O6, or I/O2. See "Write Operation Status" for information on these status bits. When the Embedded Erase algorithm is complete, the device returns to reading array data and addresses are no longer latched.

Figure 4 illustrates the algorithm for the erase operation. See the Erase/Program Operations tables in "AC Characteristics" for parameters, and to the Chip/Sector Erase Operation Timings for timing waveforms.

Sector Erase Command Sequence

Sector erase is a six-bus-cycle operation. The sector erase command sequence is initiated by writing two unlock cycles, followed by a set-up command. Two additional unlock write cycles are then followed by the address of the sector to be erased, and the sector erase command. The Command Definitions table shows the address and data requirements for the sector erase command sequence.

The device does not require the system to preprogram the memory prior to erase. The Embedded Erase algorithm automatically programs and verifies the sector for an all zero data pattern prior to electrical erase. The system is not required to provide any controls or timings during these operations.

After the command sequence is written, a sector erase time-out of 50µs begins. During the time-out period, additional sector addresses and sector erase commands may be written. Loading the sector erase buffer may be done in any sequence, and the number of sectors may be from one sector to all sectors. The time between these additional cycles must be less than 50µs, otherwise the last address and command might not be accepted, and erasure may begin. It is recommended that processor interrupts be disabled during this time to ensure all commands are accepted. The interrupts can be re-enabled after the last Sector Erase command is written. If the time between additional sector erase commands can be assumed to be less than 50µs, the system need not monitor I/O3. Any command other than Sector Erase or Erase Suspend during the time-out period resets the device to reading array data. The system must rewrite the command sequence and any additional sector addresses and commands.

The system can monitor I/O₃ to determine if the sector erase timer has timed out. (See the "I/O₃: Sector Erase Timer" section.) The time-out begins from the rising edge of the final WE pulse in the command sequence.

Once the sector erase operation has begun, only the Erase Suspend command is valid. All other commands are ignored. When the Embedded Erase algorithm is complete, the device returns to reading array data and addresses are no longer latched. The system can determine the status of the erase operation by using I/O₇, I/O₆, or I/O₂. Refer to "Write Operation Status" for information on these status bits.

4 illustrates the algorithm for the erase operation. Refer to the Erase/Program Operations tables in the "AC Characteristics" section for parameters, and to the Sector Erase Operations Timing diagram for timing waveforms.

Erase Suspend/Erase Resume Commands

The Erase Suspend command allows the system to interrupt a sector erase operation and then read data from, or program data to, any sector not selected for erasure. This command is valid only during the sector erase operation, including the 50μs time-out period during the sector erase command sequence. The Erase Suspend command is ignored if written during the chip erase operation or Embedded Program algorithm. Writing the Erase Suspend command during the Sector Erase time-out immediately terminates the time-out period and suspends the erase operation. Addresses are "don't cares" when writing the Erase Suspend command.

When the Erase Suspend command is written during a sector erase operation, the device requires a maximum of 20μs to suspend the erase operation. However, when the Erase Suspend command is written during the sector erase time-out, the device immediately terminates the time-out period and suspends the erase operation.

After the erase operation has been suspended, the system can read array data from or program data to any sector not selected for erasure. (The device "erases" all sectors selected for erasure.) Normal read and write timings and command definitions apply. Reading at any address within erase-suspended sectors produces status data on I/O₇ - I/O₆. The system can use I/O₇, I/O₆ and I/O₂ together, to determine if a sector is actively erasing or is erase-suspended. See "Write Operation Status" for information on these status bits.

After an erase-suspended program operation is complete, the system can once again read array data within non-suspended sectors. The system can determine the status of the program operation using the I/O₇ or I/O₆ status bits, just as in the standard program operation. See "Write Operation Status" for more information.

The system may also write the autoselect command sequence when the device is in the Erase Suspend mode. The device allows reading autoselect codes even at addresses within erasing sectors, since the codes are not stored in the memory array. When the device exits the autoselect mode, the device reverts to the Erase Suspend mode, and is ready for another valid operation. See "Autoselect Command Sequence" for more information.

The system must write the Erase Resume command (address bits are "don't care") to exit the erase suspend mode and continue the sector erase operation. Further writes of the Resume command are ignored. Another Erase Suspend command can be written after the device has resumed erasing.

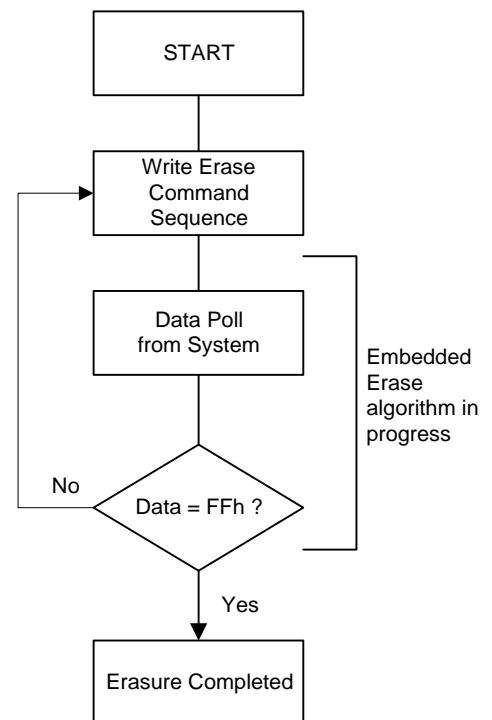

Note :

1. See the appropriate Command Definitions table for erase command sequences.
2. See "I/O₃ : Sector Erase Timer" for more information.

Figure 4. Erase Operation

Table 5. A29L008 Command Definitions

Command Sequence (Note 1)		Cycles	Bus Cycles (Notes 2 - 4)											
			First		Second		Third		Fourth		Fifth		Sixth	
			Addr	Data	Addr	Data	Addr	Data	Addr	Data	Addr	Data	Addr	Data
Read (Note 5)		1	RA	RD										
Reset (Note 6)		1	XXX	F0										
Autoselect (Note 7)	Manufacturer ID	4	555	AA	2AA	55	555	90	X00	37				
	Device ID, Top Boot Block	4	555	AA	2AA	55	555	90	X01	1A				
	Device ID, Bottom Boot Block	4	555	AA	2AA	55	555	90	X01	9B				
	Continuation ID	4	555	AA	2AA	55	555	90	X03	7F				
	Sector Protect Verify (Note 8)	4	555	AA	2AA	55	555	90	(SA) X02	XX00 XX01				
Program		4	555	AA	2AA	55	555	A0	PA	PD				
Unlock Bypass		3	555	AA	2AA	55	555	20						
Unlock Bypass Program (Note 9)		2	XXX	A0	PA	PD								
Unlock Bypass Reset (Note 10)		2	XXX	90	XXX	00								
Chip Erase		6	555	AA	2AA	55	555	80	555	AA	2AA	55	555	10
Sector Erase		6	555	AA	2AA	55	555	80	555	AA	2AA	55	SA	30
Erase Suspend (Note 11)		1	XXX	B0										
Erase Resume (Note 12)		1	XXX	30										

Legend:

X = Don't care

RA = Address of the memory location to be read.

RD = Data read from location RA during read operation.

PA = Address of the memory location to be programmed. Addresses latch on the falling edge of the \overline{WE} or \overline{CE} pulse, whichever happens later.

PD = Data to be programmed at location PA. Data latches on the rising edge of \overline{WE} or \overline{CE} pulse, whichever happens first.

SA = Address of the sector to be verified (in autoselect mode) or erased. Address bits A19 - A13 select a unique sector.

Note:

- See Table 1 for description of bus operations.
- All values are in hexadecimal.
- Except when reading array or autoselect data, all bus cycles are write operation.
- Address bits A19 - A11 are don't cares for unlock and command cycles, unless SA or PA required.
- No unlock or command cycles required when reading array data.
- The Reset command is required to return to reading array data when device is in the autoselect mode, or if I/Os goes high (while the device is providing status data).
- The fourth cycle of the autoselect command sequence is a read cycle.
- The data is 00h for an unprotected sector and 01h for a protected sector. See "Autoselect Command Sequence" for more information.
- The Unlock Bypass command is required prior to the Unlock Bypass Program command.
- The Unlock Bypass Reset command is required to return to reading array data when the device is in the unlock bypass mode.
- The system may read and program in non-erasing sectors, or enter the autoselect mode, when in the Erase Suspend mode.
- The Erase Resume command is valid only during the Erase Suspend mode.

Write Operation Status

Several bits, I/O_2 , I/O_3 , I/O_5 , I/O_6 , I/O_7 , $\overline{RY}/\overline{BY}$ are provided in the A29L008 to determine the status of a write operation. Table 6 and the following subsections describe the functions of these status bits. I/O_7 , I/O_6 and $\overline{RY}/\overline{BY}$ each offer a method for determining whether a program or erase operation is complete or in progress. These three bits are discussed first.

I/O_7 : $\overline{\text{Data}}$ Polling

The $\overline{\text{Data}}$ Polling bit, I/O_7 , indicates to the host system whether an Embedded Algorithm is in progress or completed, or whether the device is in Erase Suspend. $\overline{\text{Data}}$ Polling is valid after the rising edge of the final \overline{WE} pulse in the program or erase command sequence.

During the Embedded Program algorithm, the device outputs on I/O_7 the complement of the datum programmed to I/O_7 . This I/O_7 status also applies to programming during Erase Suspend. When the Embedded Program algorithm is complete, the device outputs the datum programmed to I/O_7 . The system must provide the program address to read valid status information on I/O_7 . If a program address falls within a protected sector, $\overline{\text{Data}}$ Polling on I/O_7 is active for approximately $2\mu\text{s}$, then the device returns to reading array data.

During the Embedded Erase algorithm, $\overline{\text{Data}}$ Polling produces a "0" on I/O_7 . When the Embedded Erase algorithm is complete, or if the device enters the Erase Suspend mode, $\overline{\text{Data}}$ Polling produces a "1" on I/O_7 . This is analogous to the complement/true datum output described for the Embedded Program algorithm: the erase function changes all the bits in a sector to "1"; prior to this, the device outputs the "complement," or "0." The system must provide an address within any of the sectors selected for erasure to read valid status information on I/O_7 .

After an erase command sequence is written, if all sectors selected for erasing are protected, $\overline{\text{Data}}$ Polling on I/O_7 is active for approximately $100\mu\text{s}$, then the device returns to reading array data. If not all selected sectors are protected, the Embedded Erase algorithm erases the unprotected sectors, and ignores the selected sectors that are protected. When the system detects I/O_7 has changed from the complement to true data, it can read valid data at $I/O_7 - I/O_0$ on the following read cycles. This is because I/O_7 may change asynchronously with $I/O_0 - I/O_6$ while Output Enable (\overline{OE}) is asserted low. The $\overline{\text{Data}}$ Polling Timings (During Embedded Algorithms) in the "AC Characteristics" section illustrates this. Table 6 shows the outputs for $\overline{\text{Data}}$ Polling on I/O_7 . Figure 5 shows the $\overline{\text{Data}}$ Polling algorithm.

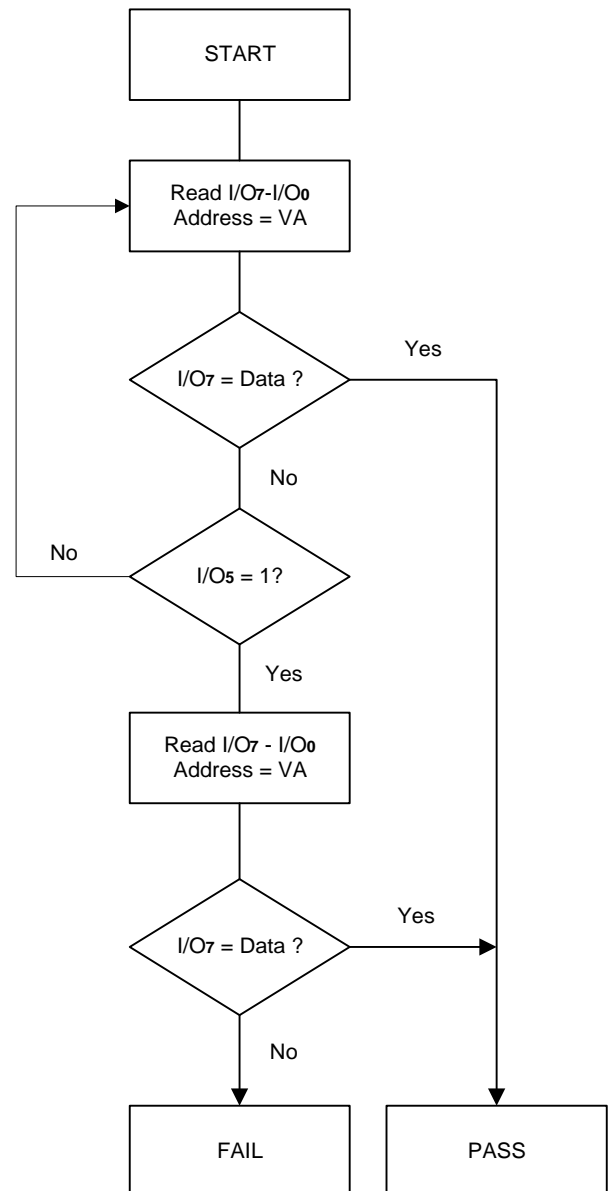

Note :

1. VA = Valid address for programming. During a sector erase operation, a valid address is an address within any sector selected for erasure. During chip erase, a valid address is any non-protected sector address.
2. I/O_7 should be rechecked even if $I/O_6 = "1"$ because I/O_7 may change simultaneously with I/O_6 .

Figure 5. $\overline{\text{Data}}$ Polling Algorithm

$\overline{RY}/\overline{BY}$: Read/ \overline{Busy}

The $\overline{RY}/\overline{BY}$ is a dedicated, open-drain output pin that indicates whether an Embedded algorithm is in progress or complete. The $\overline{RY}/\overline{BY}$ status is valid after the rising edge of the final \overline{WE} pulse in the command sequence. Since $\overline{RY}/\overline{BY}$ is an open-drain output, several $\overline{RY}/\overline{BY}$ pins can be tied together in parallel with a pull-up resistor to VCC.

If the output is low (Busy), the device is actively erasing or programming. (This includes programming in the Erase Suspend mode.) If the output is high (Ready), the device is ready to read array data (including during the Erase Suspend mode), or is in the standby mode.

Table 6 shows the outputs for $\overline{RY}/\overline{BY}$. Refer to "RESET Timings", "Timing Waveforms for Program Operation" and "Timing Waveforms for Chip/Sector Erase Operation" for more information.

I/O_6 : Toggle Bit I

Toggle Bit I on I/O_6 indicates whether an Embedded Program or Erase algorithm is in progress or complete, or whether the device has entered the Erase Suspend mode. Toggle Bit I may be read at any address, and is valid after the rising edge of the final \overline{WE} pulse in the command sequence (prior to the program or erase operation), and during the sector erase time-out.

During an Embedded Program or Erase algorithm operation, successive read cycles to any address cause I/O_6 to toggle. (The system may use either \overline{OE} or \overline{CE} to control the read cycles.) When the operation is complete, I/O_6 stops toggling.

After an erase command sequence is written, if all sectors selected for erasing are protected, I/O_6 toggles for approximately 100 μ s, then returns to reading array data. If not all selected sectors are protected, the Embedded Erase algorithm erases the unprotected sectors, and ignores the selected sectors that are protected.

The system can use I/O_6 and I/O_2 together to determine whether a sector is actively erasing or is erase-suspended. When the device is actively erasing (that is, the Embedded Erase algorithm is in progress), I/O_6 toggles. When the device enters the Erase Suspend mode, I/O_6 stops toggling. However, the system must also use I/O_2 to determine which sectors are erasing or erase-suspended. Alternatively, the system can use I/O_7 (see the subsection on " I/O_7 : Data Polling").

If a program address falls within a protected sector, I/O_6 toggles for approximately 2 μ s after the program command sequence is written, then returns to reading array data.

I/O_6 also toggles during the erase-suspend-program mode, and stops toggling once the Embedded Program algorithm is complete.

The Write Operation Status table shows the outputs for Toggle Bit I on I/O_6 . Refer to Figure 6 for the toggle bit algorithm, and to the Toggle Bit Timings figure in the "AC Characteristics" section for the timing diagram. The I/O_2 vs. I/O_6 figure shows the differences between I/O_2 and I/O_6 in graphical form. See also the subsection on " I/O_2 : Toggle Bit II".

I/O_2 : Toggle Bit II

The "Toggle Bit II" on I/O_2 , when used with I/O_6 , indicates whether a particular sector is actively erasing (that is, the Embedded Erase algorithm is in progress), or whether that

sector is erase-suspended. Toggle Bit II is valid after the rising edge of the final \overline{WE} pulse in the command sequence. I/O_2 toggles when the system reads at addresses within those sectors that have been selected for erasure. (The system may use either \overline{OE} or \overline{CE} to control the read cycles.) But I/O_2 cannot distinguish whether the sector is actively erasing or is erase-suspended. I/O_6 , by comparison, indicates whether the device is actively erasing, or is in Erase Suspend, but cannot distinguish which sectors are selected for erasure. Thus, both status bits are required for sector and mode information. Refer to Table 6 to compare outputs for I/O_2 and I/O_6 .

Figure 6 shows the toggle bit algorithm in flowchart form, and the section " I/O_2 : Toggle Bit II" explains the algorithm. See also the " I/O_6 : Toggle Bit I" subsection. Refer to the Toggle Bit Timings figure for the toggle bit timing diagram. The I/O_2 vs. I/O_6 figure shows the differences between I/O_2 and I/O_6 in graphical form.

Reading Toggle Bits I/O_6 , I/O_2

Refer to Figure 6 for the following discussion. Whenever the system initially begins reading toggle bit status, it must read I/O_7 - I/O_0 at least twice in a row to determine whether a toggle bit is toggling. Typically, a system would note and store the value of the toggle bit after the first read. After the second read, the system would compare the new value of the toggle bit with the first. If the toggle bit is not toggling, the device has completed the program or erase operation. The system can read array data on I/O_7 - I/O_0 on the following read cycle.

However, if after the initial two read cycles, the system determines that the toggle bit is still toggling, the system also should note whether the value of I/O_5 is high (see the section on I/O_5). If it is, the system should then determine again whether the toggle bit is toggling, since the toggle bit may have stopped toggling just as I/O_5 went high. If the toggle bit is no longer toggling, the device has successfully completed the program or erase operation. If it is still toggling, the device did not complete the operation successfully, and the system must write the reset command to return to reading array data.

The remaining scenario is that the system initially determines that the toggle bit is toggling and I/O_5 has not gone high. The system may continue to monitor the toggle bit and I/O_5 through successive read cycles, determining the status as described in the previous paragraph. Alternatively, it may choose to perform other system tasks. In this case, the system must start at the beginning of the algorithm when it returns to determine the status of the operation (top of Figure 6).

I/O_5 : Exceeded Timing Limits

I/O_5 indicates whether the program or erase time has exceeded a specified internal pulse count limit. Under these conditions I/O_5 produces a "1." This is a failure condition that indicates the program or erase cycle was not successfully completed.

The I/O_5 failure condition may appear if the system tries to program a "1" to a location that is previously programmed to "0." Only an erase operation can change a "0" back to a "1." Under this condition, the device halts the operation, and when the operation has exceeded the timing limits, I/O_5 produces a "1."

Under both these conditions, the system must issue the reset command to return the device to reading array data.

I/O₃: Sector Erase Timer

After writing a sector erase command sequence, the system may read I/O₃ to determine whether or not an erase operation has begun. (The sector erase timer does not apply to the chip erase command.) If additional sectors are selected for erasure, the entire time-out also applies after each additional sector erase command. When the time-out is complete, I/O₃ switches from "0" to "1." The system may ignore I/O₃ if the system can guarantee that the time between additional sector erase commands will always be less than 50μs. See also the "Sector Erase Command Sequence" section.

After the sector erase command sequence is written, the system should read the status on I/O₇ ($\overline{\text{Data}}$ Polling) or I/O₆ (Toggle Bit I) to ensure the device has accepted the command sequence, and then read I/O₃. If I/O₃ is "1", the internally controlled erase cycle has begun; all further commands (other than Erase Suspend) are ignored until the erase operation is complete. If I/O₃ is "0", the device will accept additional sector erase commands. To ensure the command has been accepted, the system software should check the status of I/O₃ prior to and following each subsequent sector erase command. If I/O₃ is high on the second status check, the last command might not have been accepted. Table 6 shows the outputs for I/O₃.

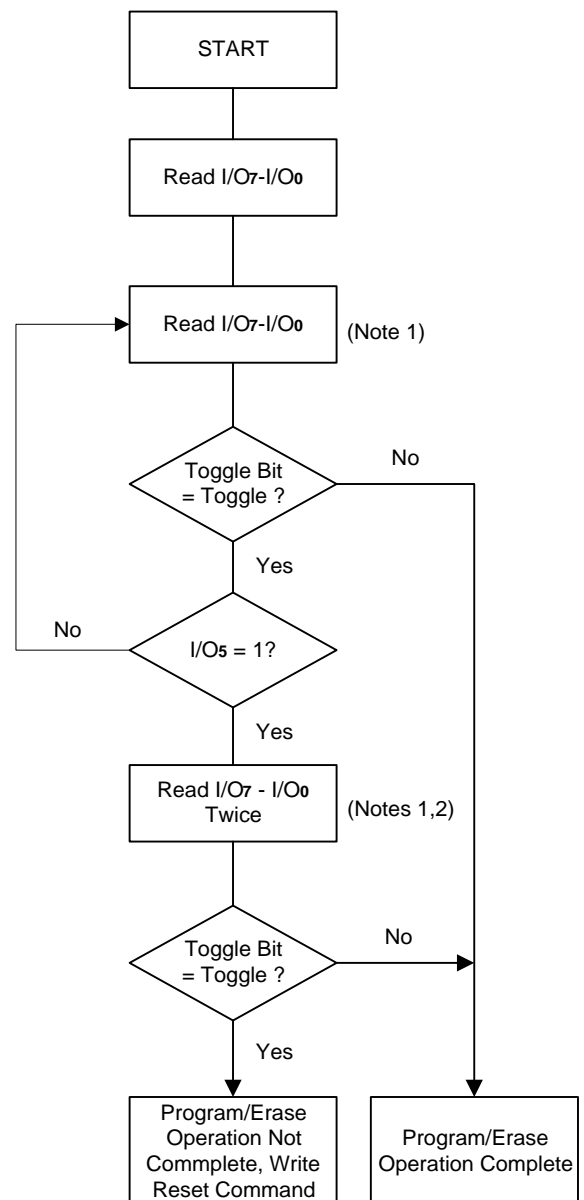

Notes :

1. Read toggle bit twice to determine whether or not it is toggling. See text.
2. Recheck toggle bit because it may stop toggling as I/O₅ changes to "1". See text.

Figure 6. Toggle Bit Algorithm

Table 6. Write Operation Status

Operation		I/O ₇ (Note 1)	I/O ₆	I/O ₅ (Note 2)	I/O ₃	I/O ₂ (Note 1)	RY/ $\overline{\text{BY}}$
Standard Mode	Embedded Program Algorithm	$\overline{\text{I/O}}_7$	Toggle	0	N/A	No toggle	0
	Embedded Erase Algorithm	0	Toggle	0	1	Toggle	0
Erase Suspend Mode	Reading within Erase Suspended Sector	1	No toggle	0	N/A	Toggle	1
	Reading within Non-Erase Suspended Sector	Data	Data	Data	Data	Data	1
	Erase-Suspend-Program	$\overline{\text{I/O}}_7$	Toggle	0	N/A	N/A	0

Notes:

1. I/O₇ and I/O₂ require a valid address when reading status information. Refer to the appropriate subsection for further details.
2. I/O₅ switches to "1" when an Embedded Program or Embedded Erase operation has exceeded the maximum timing limits. See "I/O₅: Exceeded Timing Limits" for more information.

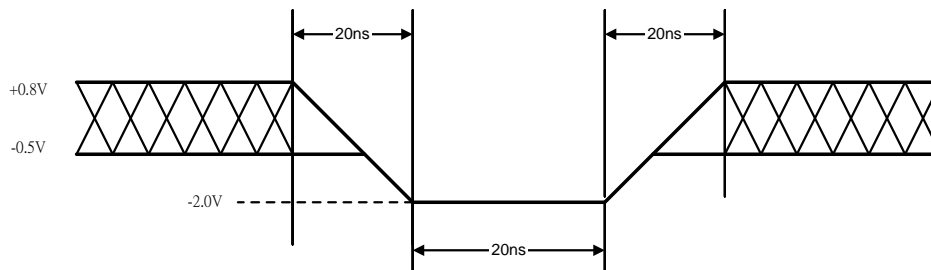
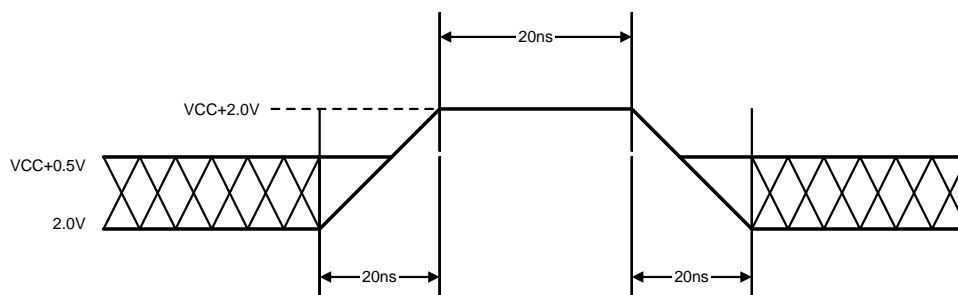
Maximum Negative Input Overshoot

Maximum Positive Input Overshoot

DC Characteristics
CMOS Compatible ($T_A=0^{\circ}\text{C}$ to 70°C or -40°C to $+85^{\circ}\text{C}$)

Parameter Symbol	Parameter Description	Test Description	Min.	Typ.	Max.	Unit
I_{LI}	Input Load Current	$V_{IN} = V_{SS}$ to V_{CC} . $V_{CC} = V_{CC}$ Max			± 1.0	μA
I_{LIT}	A9 Input Load Current	$V_{CC} = V_{CC}$ Max, A9 = 12.5V			35	μA
I_{LO}	Output Leakage Current	$V_{OUT} = V_{SS}$ to V_{CC} . $V_{CC} = V_{CC}$ Max			± 1.0	μA
I_{CC1}	VCC Active Read Current (Notes 1, 2)	$\overline{CE} = V_{IL}$, $\overline{OE} = V_{IH}$	5 MHz	9	16	mA
		Byte Mode	1 MHz	2	4	
		$\overline{CE} = V_{IL}$, $\overline{OE} = V_{IH}$	5 MHz	9	16	
		Word Mode	1 MHz	2	4	
I_{CC2}	VCC Active Write (Program/Erase) Current (Notes 2, 3, 4)	$\overline{CE} = V_{IL}$, $\overline{OE} = V_{IH}$		20	30	mA
I_{CC3}	VCC Standby Current (Note 2)	$\overline{CE} = V_{IH}$, $\overline{RESET} = V_{CC} \pm 0.3\text{V}$		0.2	5	μA
I_{CC4}	VCC Standby Current During Reset (Note 2)	$\overline{RESET} = V_{SS} \pm 0.3\text{V}$		0.2	5	μA
I_{CC5}	Automatic Sleep Mode (Note 2, 4, 5)	$V_{IH} = V_{CC} \pm 0.3\text{V}$; $V_{IL} = V_{SS} \pm 0.3\text{V}$		0.2	5	μA
V_{IL}	Input Low Level		-0.5		0.8	V
V_{IH}	Input High Level		$0.7 \times V_{CC}$		$V_{CC} + 0.3$	V
V_{ID}	Voltage for Autoselect and Temporary Unprotect Sector	$V_{CC} = 3.3\text{V}$	11.5		12.5	V
V_{OL}	Output Low Voltage	$I_{OL} = 4.0\text{mA}$, $V_{CC} = V_{CC}$ Min			0.45	V
V_{OH1}	Output High Voltage	$I_{OH} = -2.0\text{mA}$, $V_{CC} = V_{CC}$ Min	$0.85 \times V_{CC}$			V
V_{OH2}		$I_{OH} = -100\ \mu\text{A}$, $V_{CC} = V_{CC}$ Min	$V_{CC} - 0.4$			V

Notes:

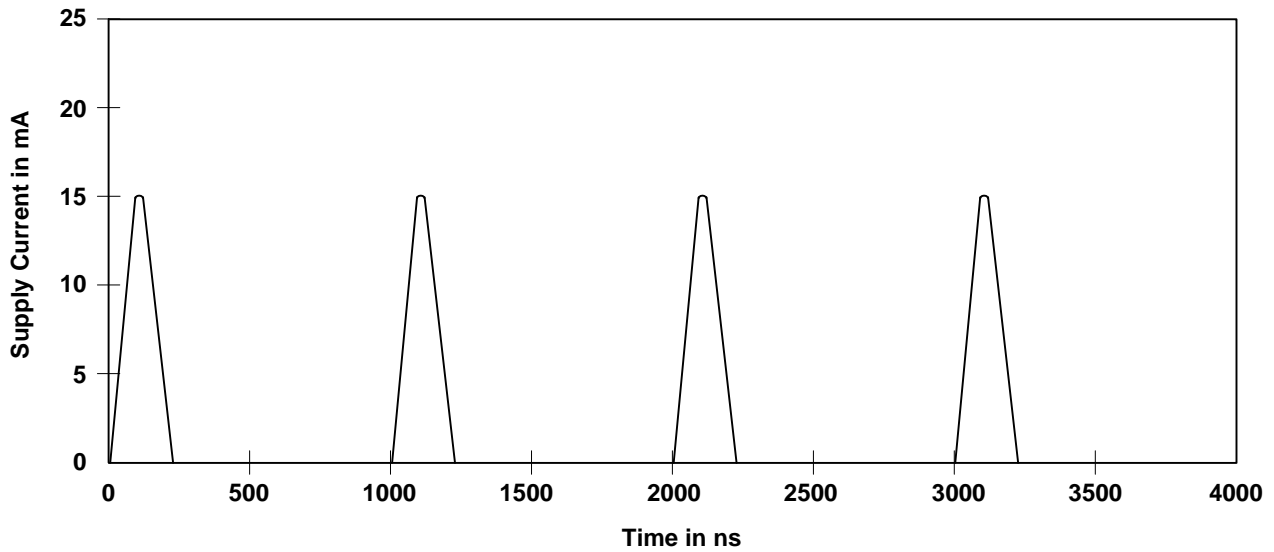
1. The I_{CC} current listed is typically less than 2 mA/MHz, with \overline{OE} at V_{IH} . Typical V_{CC} is 3.0V.
2. Maximum I_{CC} specifications are tested with $V_{CC} = V_{CC}$ max.
3. I_{CC} active while Embedded Algorithm (program or erase) is in progress.
4. Automatic sleep mode enables the low power mode when addresses remain stable for $t_{acc} + 30\text{ns}$. Typical sleep mode current is 200nA.
5. Not 100% tested.

DC Characteristics (continued)
Zero Power Flash

Note: Addresses are switching at 1MHz

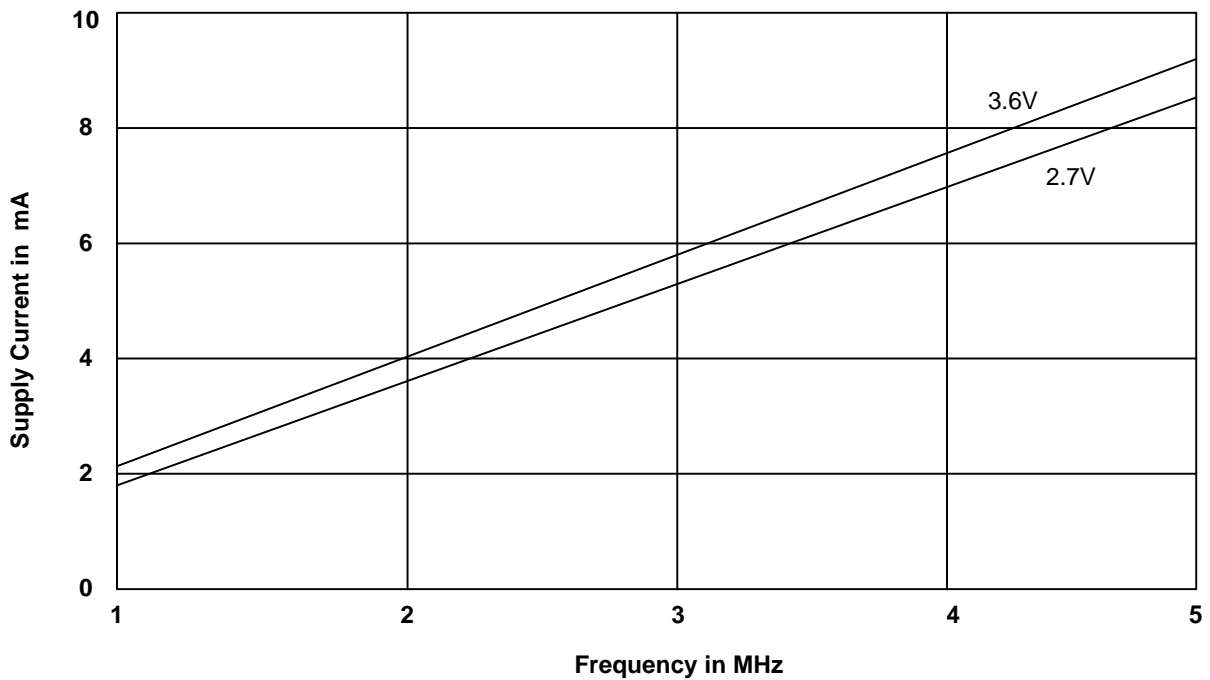
Icc1 Current vs. Time (Showing Active and Automatic Sleep Currents)

Note : T = 25°C

Typical Icc1 vs. Frequency

AC Characteristics
Read Only Operations ($T_A=0^{\circ}\text{C}$ to 70°C or -40°C to $+85^{\circ}\text{C}$)

Parameter Symbols		Description	Test Setup		Speed		Unit
JEDEC	Std				-70	-90	
tAVAV	trc	Read Cycle Time (Note 1)		Min.	70	90	ns
tAVQV	tACC	Address to Output Delay	$\overline{\text{CE}} = V_{\text{IL}}$ $\overline{\text{OE}} = V_{\text{IL}}$	Max.	70	90	ns
tELQV	tCE	Chip Enable to Output Delay	$\overline{\text{OE}} = V_{\text{IL}}$	Max.	70	90	ns
tGLQV	toE	Output Enable to Output Delay		Max.	30	35	ns
	toEH	Output Enable Hold Time (Note 1)	Read	Min.	0	0	ns
			Toggle and Data Polling	Min.	10	10	ns
tEHQZ	tDF	Chip Enable to Output High Z (Notes 1)		Max.	25	30	ns
tGHQZ	tDF	Output Enable to Output High Z (Notes 1)			25	30	ns
tAXQX	toH	Output Hold Time from Addresses, $\overline{\text{CE}}$ or $\overline{\text{OE}}$, Whichever Occurs First (Note 1)		Min.	0	0	ns

Notes:

1. Not 100% tested.
2. See Test Conditions and Test Setup for test specifications.

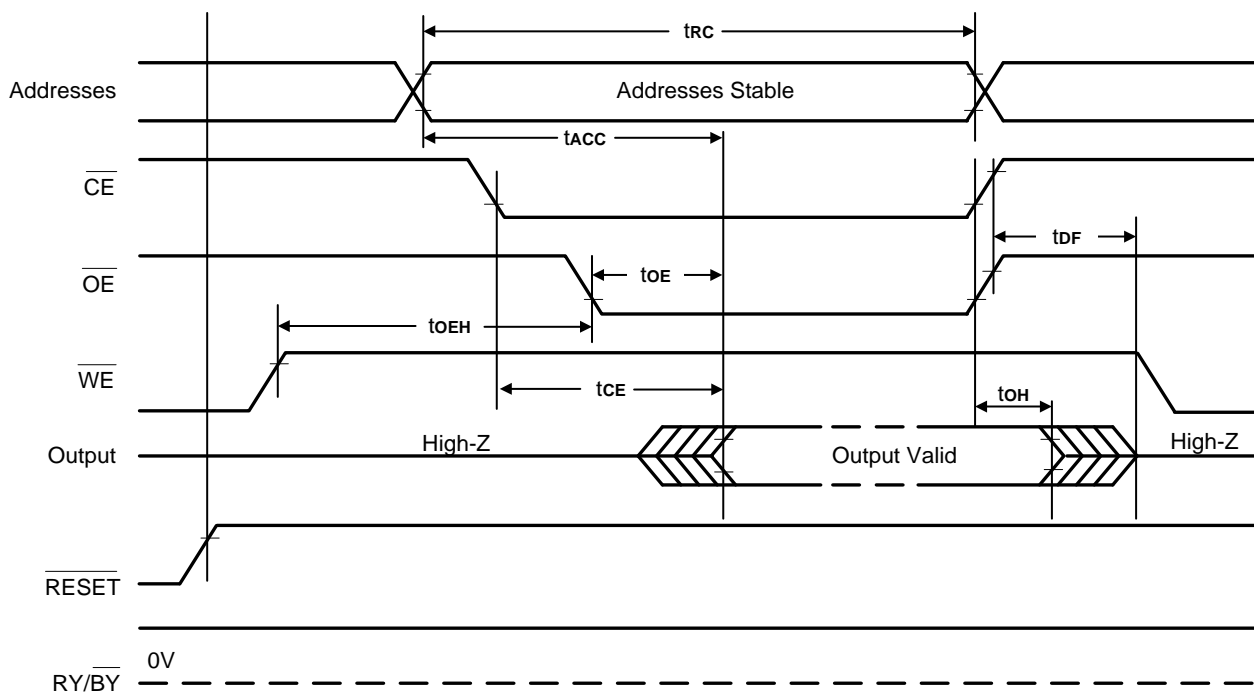
Timing Waveforms for Read Only Operation

AC Characteristics
Hardware Reset ($\overline{\text{RESET}}$) ($T_A=0^\circ\text{C}$ to 70°C or -40°C to $+85^\circ\text{C}$)

Parameter		Description	Test Setup		All Speed Options	Unit
JEDEC	Std					
	t_{READY}	$\overline{\text{RESET}}$ Pin Low (During Embedded Algorithms) to Read or Write (See Note)		Max	20	μs
	t_{READY}	$\overline{\text{RESET}}$ Pin Low (Not During Embedded Algorithms) to Read or Write (See Note)		Max	500	ns
	t_{RP}	$\overline{\text{RESET}}$ Pulse Width		Min	500	ns
	t_{RH}	$\overline{\text{RESET}}$ High Time Before Read (See Note)		Min	50	ns
	t_{RB}	$\text{RY}/\overline{\text{BY}}$ Recovery Time		Min	0	ns
	t_{RPD}	$\overline{\text{RESET}}$ Low to Standby Mode		Min	20	μs

Note: Not 100% tested.

 $\overline{\text{RESET}}$ Timings

Temporary Sector Unprotect ($T_A=0^{\circ}\text{C}$ to 70°C or -40°C to $+85^{\circ}\text{C}$)

Parameter		Description		All Speed Options	Unit
JEDEC	Std				
	tVIDR	V _{ID} Rise and Fall Time (See Note)	Min	500	ns
	tRSP	RESET Setup Time for Temporary Sector Unprotect	Min	4	μs

Note: Not 100% tested.

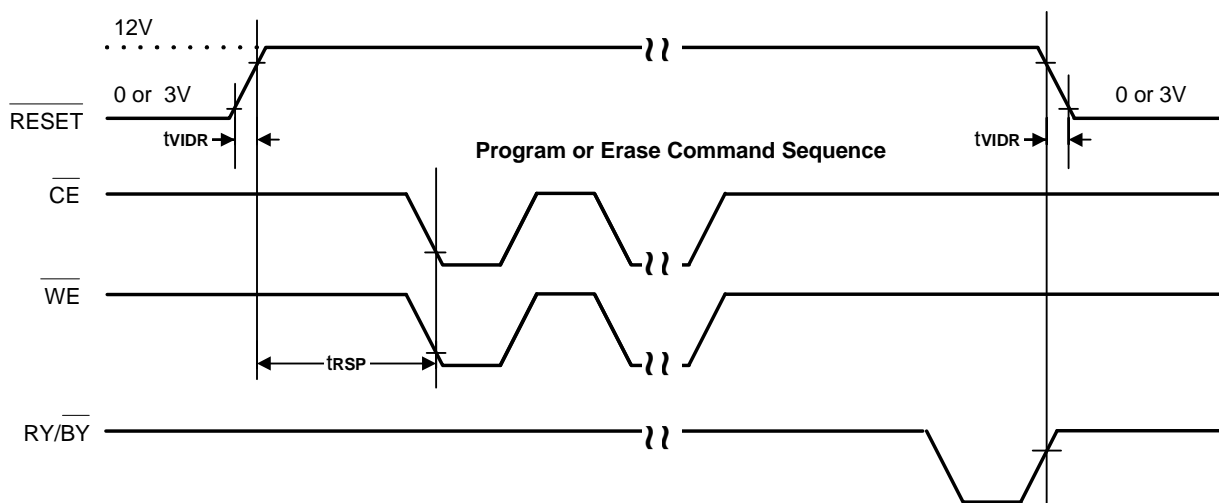
Temporary Sector Unprotect Timing Diagram

AC Characteristics
Erase and Program Operations (T_A=0°C to 70°C or -40°C to +85°C)

Parameter		Description		Speed		Unit
JEDEC	Std			-70	-90	
t _{AVAV}	t _{wc}	Write Cycle Time (Note 1)	Min.	70	90	ns
t _{AVWL}	t _{as}	Address Setup Time	Min.	0		ns
t _{WLAX}	t _{ah}	Address Hold Time	Min.	45	45	ns
t _{dvWH}	t _{ds}	Data Setup Time	Min.	35	45	ns
t _{wHDX}	t _{dh}	Data Hold Time	Min.	0		ns
	t _{oes}	Output Enable Setup Time	Min.	0		ns
t _{ghWL}	t _{ghWL}	Read Recover Time Before Write (\overline{OE} high to \overline{WE} low)	Min.	0		ns
t _{elWL}	t _{cs}	\overline{CE} Setup Time	Min.	0		ns
t _{wHEH}	t _{ch}	\overline{CE} Hold Time	Min.	0		ns
t _{wLWH}	t _{wP}	Write Pulse Width	Min.	35	35	ns
t _{wHWL}	t _{wPH}	Write Pulse Width High	Min.	30		ns
t _{whWH1}	t _{whWH1}	Programming Operation (Note 2)	Typ.	5		μs
t _{whWH2}	t _{whWH2}	Sector Erase Operation (Note 2)	Typ.	0.7		sec
	t _{vcs}	VCC Set Up Time (Note 1)	Min.	50		μs
	t _{rb}	Recovery Time from RY/ \overline{BY}	Min.	0		ns
	t _{busy}	Program/Erase Valid to RY/ \overline{BY} Delay	Min.	90		ns

Notes:

1. Not 100% tested.
2. See the "Erase and Programming Performance" section for more information.

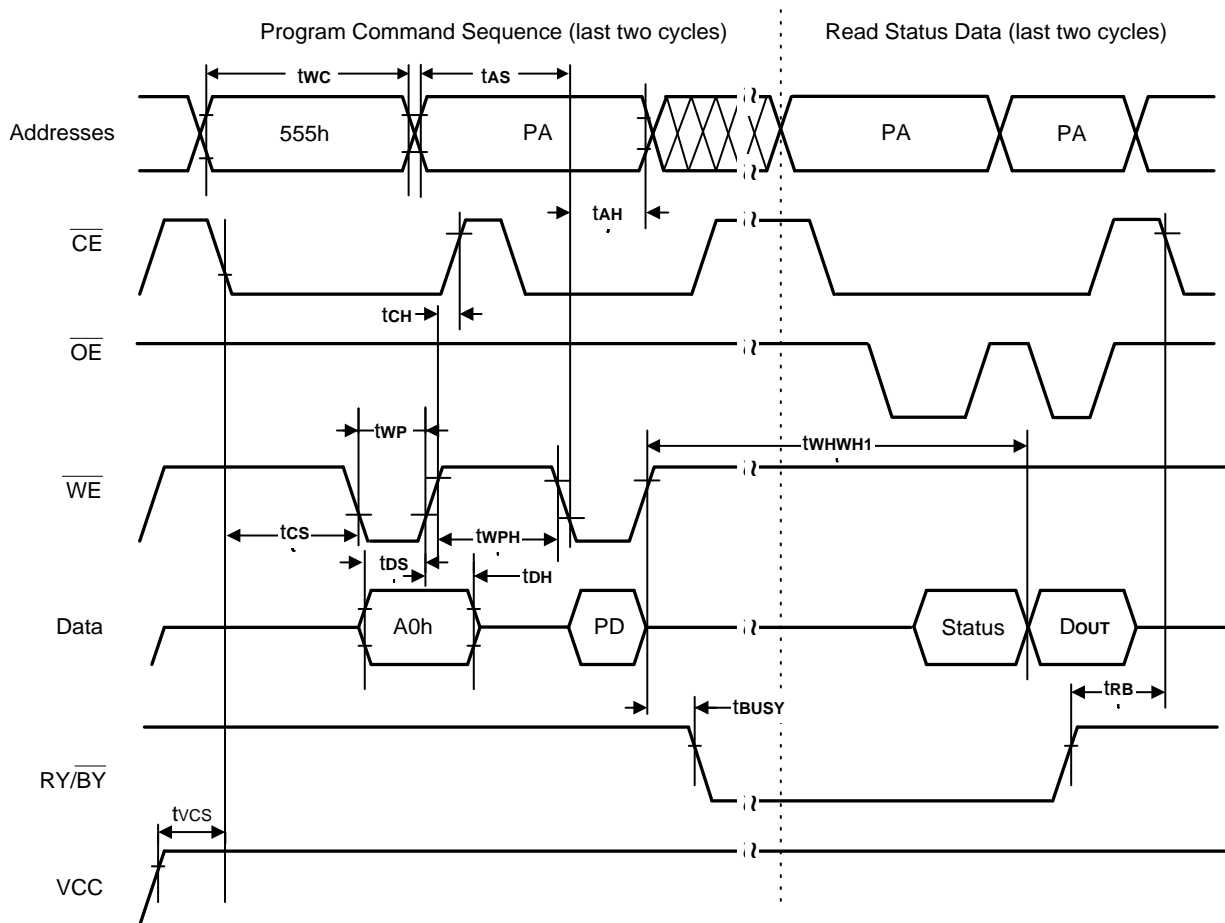
Timing Waveforms for Program Operation

Note :

1. PA = program address, PD = program data, Dour is the true data at the program address.
2. Illustration shows device in word mode.

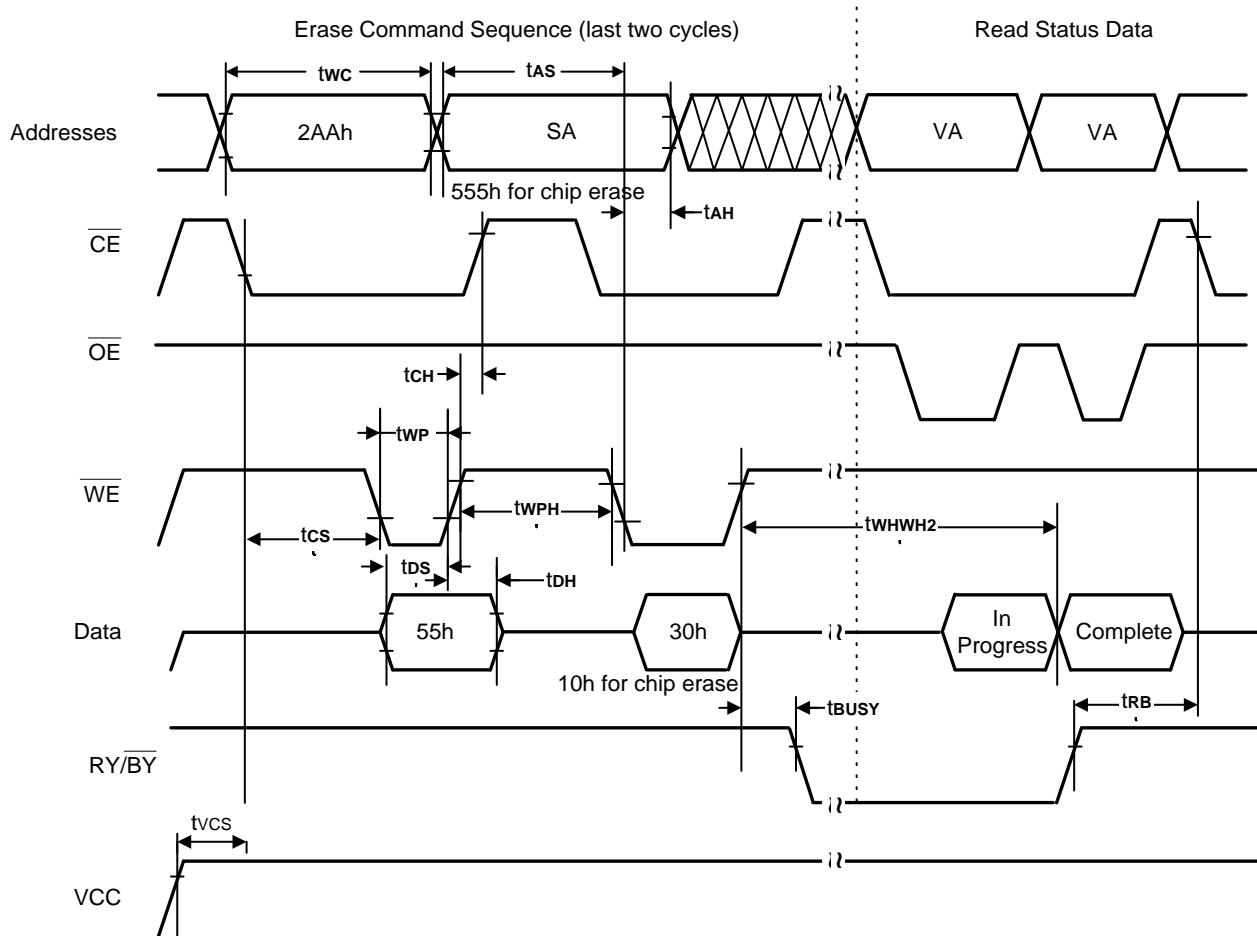
Timing Waveforms for Chip/Sector Erase Operation

Note :

1. SA = Sector Address (for Sector Erase), VA = Valid Address for reading status data (see "Write Operation Status").
2. Illustration shows device in word mode.

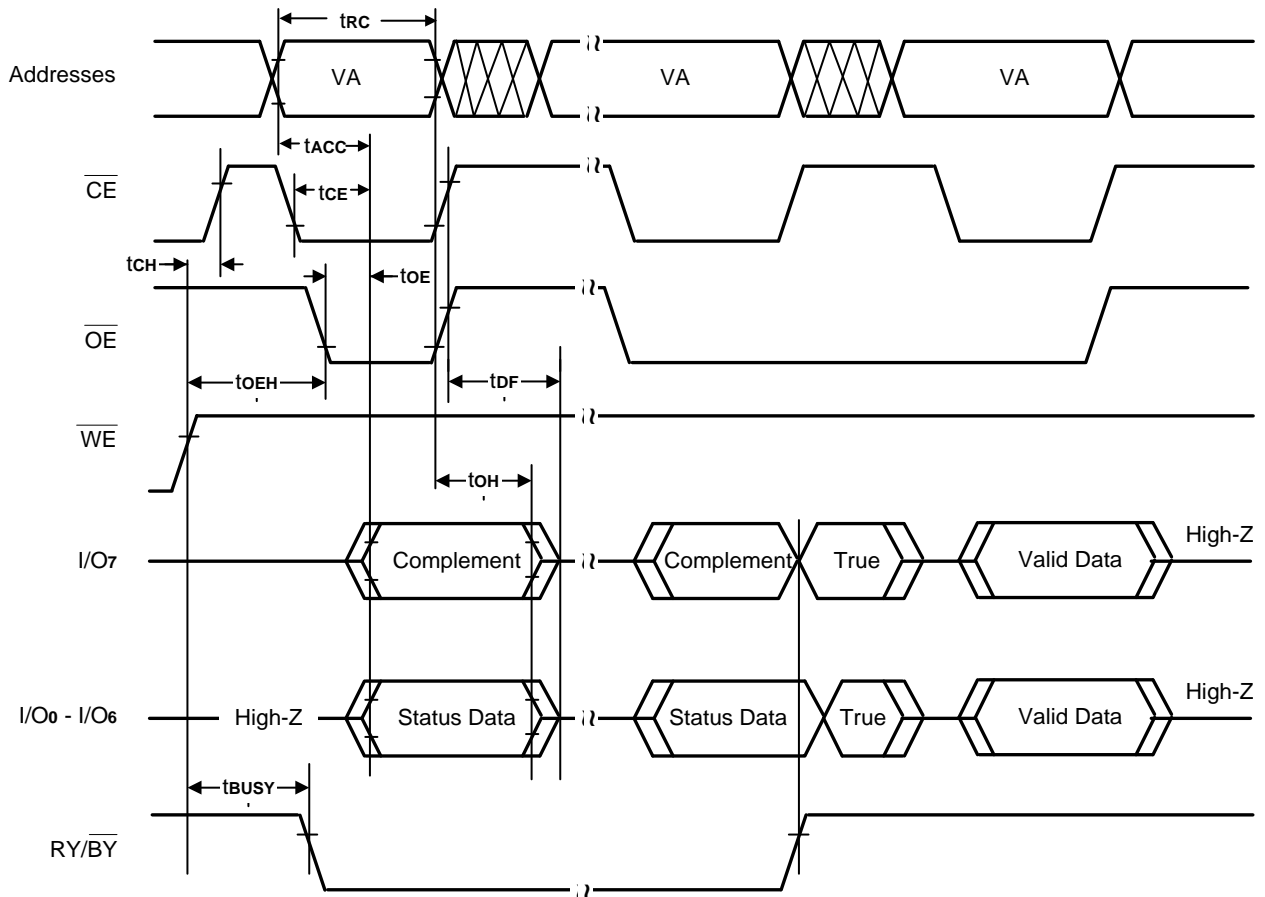
Timing Waveforms for Data Polling (During Embedded Algorithms)

Note : VA = Valid Address. Illustration shows first status cycle after command sequence, last status read cycle, and array data read cycle.

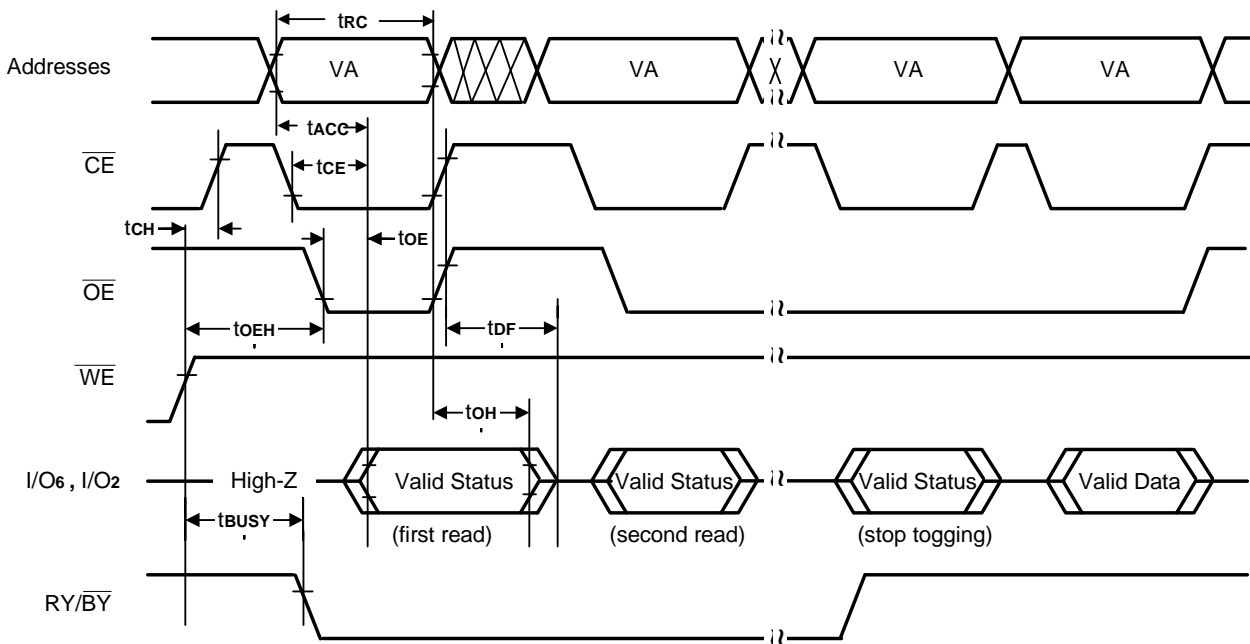
Timing Waveforms for Toggle Bit (During Embedded Algorithms)

Note: VA = Valid Address; not required for I/O₆. Illustration shows first two status cycle after command sequence, last status read cycle, and array data read cycle.

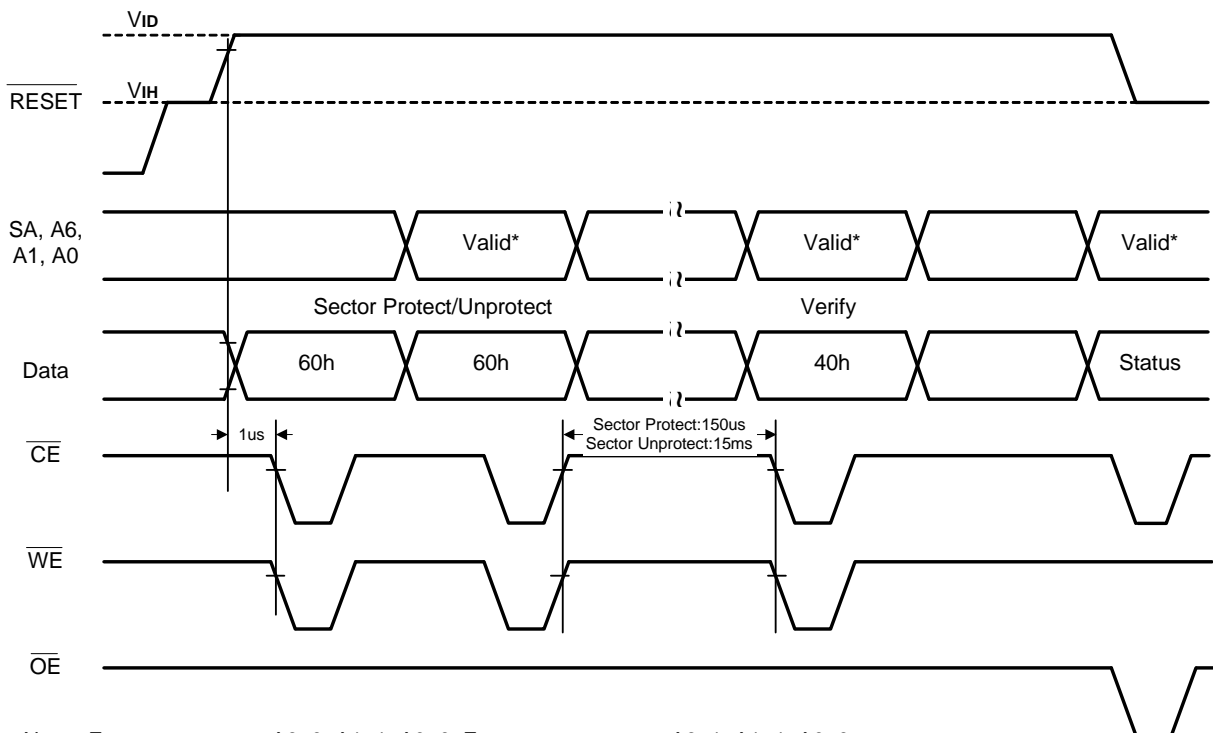
Timing Waveforms for Sector Protect/Unprotect

Note : For sector protect, A₆=0, A₁=1, A₀=0. For sector unprotect, A₆=1, A₁=1, A₀=0

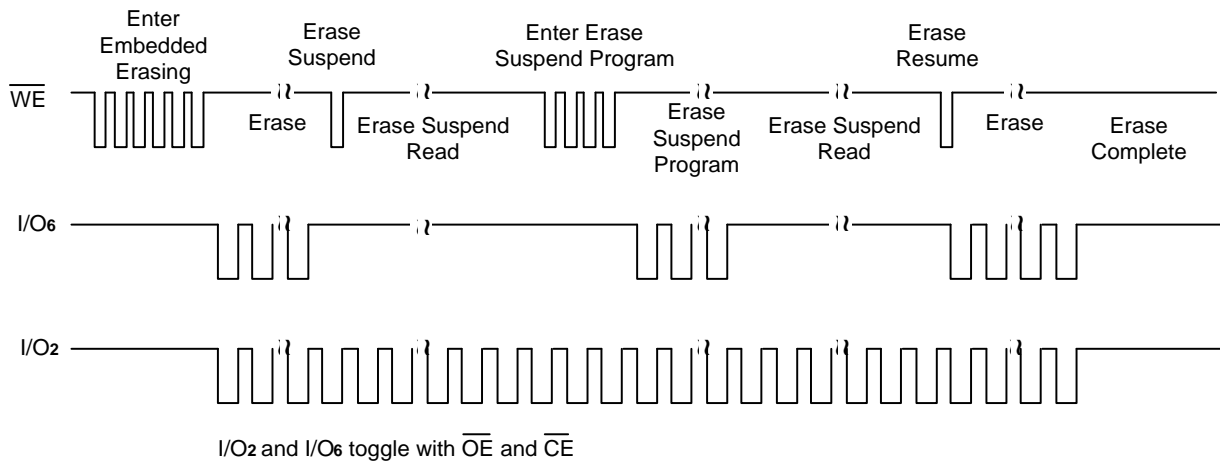
Timing Waveforms for I/O₂ vs. I/O₆

Note : Both I/O₆ and I/O₂ toggle with \overline{OE} or \overline{CE} . See the text on I/O₆ and I/O₂ in the section "Write Operation Status" for more information.

AC Characteristics
Erase and Program Operations

Alternate \overline{CE} Controlled Writes ($T_A=0^\circ\text{C}$ to 70°C or -40°C to $+85^\circ\text{C}$)

Parameter		Description		Speed		Unit
JEDEC	Std			-70	-90	
tAVAV	twc	Write Cycle Time (Note 1)	Min.	70	90	ns
tAVEL	tas	Address Setup Time	Min.	0		ns
tELAX	tAH	Address Hold Time	Min.	45	45	ns
tDVEH	tDS	Data Setup Time	Min.	35	45	ns
tHDX	tDH	Data Hold Time	Min.	0		ns
	tOES	Output Enable Setup Time	Min.	0		ns
tGHEL	tGHEL	Read Recover Time Before Write (\overline{OE} High to \overline{WE} Low)	Min.	0		ns
twLEL	tWS	\overline{WE} Setup Time	Min.	0		ns
tEWHH	tWH	\overline{WE} Hold Time	Min.	0		ns
tELEH	tCP	\overline{CE} Pulse Width	Min.	35	35	ns
tEHEL	tCPH	\overline{CE} Pulse Width High	Min.	30		ns
tWHWH1	tWHWH1	Programming Operation (Note 2)	Typ.	5		μs
tWHWH2	tWHWH2	Sector Erase Operation (Note 2)	Typ.	0.7		sec

Notes:

1. Not 100% tested.
2. See the "Erase and Programming Performance" section for more information.

Latch-up Characteristics

Description	Min.	Max.
Input Voltage with respect to VSS on all I/O pins	-1.0V	VCC+1.0V
VCC Current	-100 mA	+100 mA
Input voltage with respect to VSS on all pins except I/O pins (including A9, \overline{OE} and \overline{RESET})	-1.0V	12.5V

Includes all pins except VCC. Test conditions: VCC = 3.3V, one pin at time.

TSOP Pin Capacitance

Parameter Symbol	Parameter Description	Test Setup	Typ.	Max.	Unit
C _{IN}	Input Capacitance	V _{IN} =0	6	7.5	pF
C _{OUT}	Output Capacitance	V _{OUT} =0	8.5	12	pF
C _{IN2}	Control Pin Capacitance	V _{IN} =0	7.5	9	pF

Notes:

1. Sampled, not 100% tested.
2. Test conditions T_A = 25°C, f = 1.0MHz

Data Retention

Parameter	Test Conditions	Min	Unit
Minimum Pattern Data Retention Time	150°C	10	Years
	125°C	20	Years

Test Conditions

Test Specifications

Test Condition	-70	-90	Unit
Output Load	1 TTL gate		
Output Load Capacitance, C_L (including jig capacitance)	30	100	pF
Input Rise and Fall Times	5	5	ns
Input Pulse Levels	0.0 - 3.0	0.0 - 3.0	V
Input timing measurement reference levels	1.5	1.5	V
Output timing measurement reference levels	1.5	1.5	V

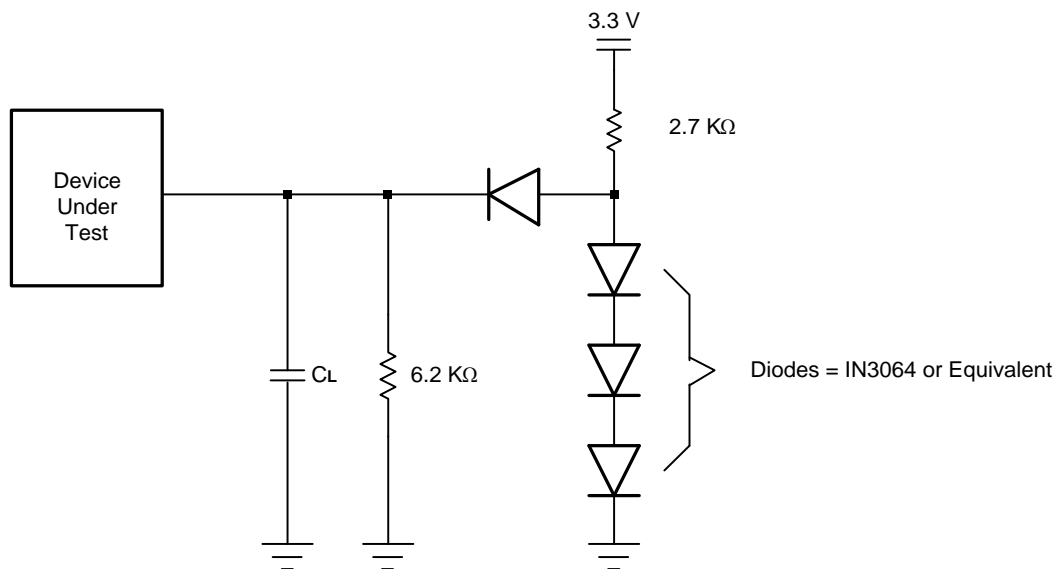
Test Setup

Ordering Information
Top Boot Sector Flash

Part No.	Access Time (ns)	Active Read Current Typ. (mA)	Program/Erase Current Typ. (mA)	Standby Current Typ. (μ A)	Package
A29L008TV-70	70	9	20	0.2	40-pin TSOP
A29L008TV-70F					40-pin Pb-Free TSOP
A29L008TV-90	90	9	20	0.2	40-pin TSOP
A29L008TV-90F					40-pin Pb-Free TSOP
A29L008TV-90U					40-pin TSOP
A29L008TV-90UF					40-pin Pb-Free TSOP

Bottom Boot Sector Flash

Part No.	Access Time (ns)	Active Read Current Typ. (mA)	Program/Erase Current Typ. (mA)	Standby Current Typ. (μ A)	Package
A29L008UV-70	70	9	20	0.2	40-pin TSOP
A29L008UV-70F					40-pin Pb-Free TSOP
A29L008UV-90	90	9	20	0.2	40-pin TSOP
A29L008UV-90F					40-pin Pb-Free TSOP
A29L008UV-90U					40-pin TSOP
A29L008UV-90UF					40-pin Pb-Free TSOP

Package Information
TSOP 40L TYPE I (10 X 20mm) Outline Dimensions

unit: inches/mm

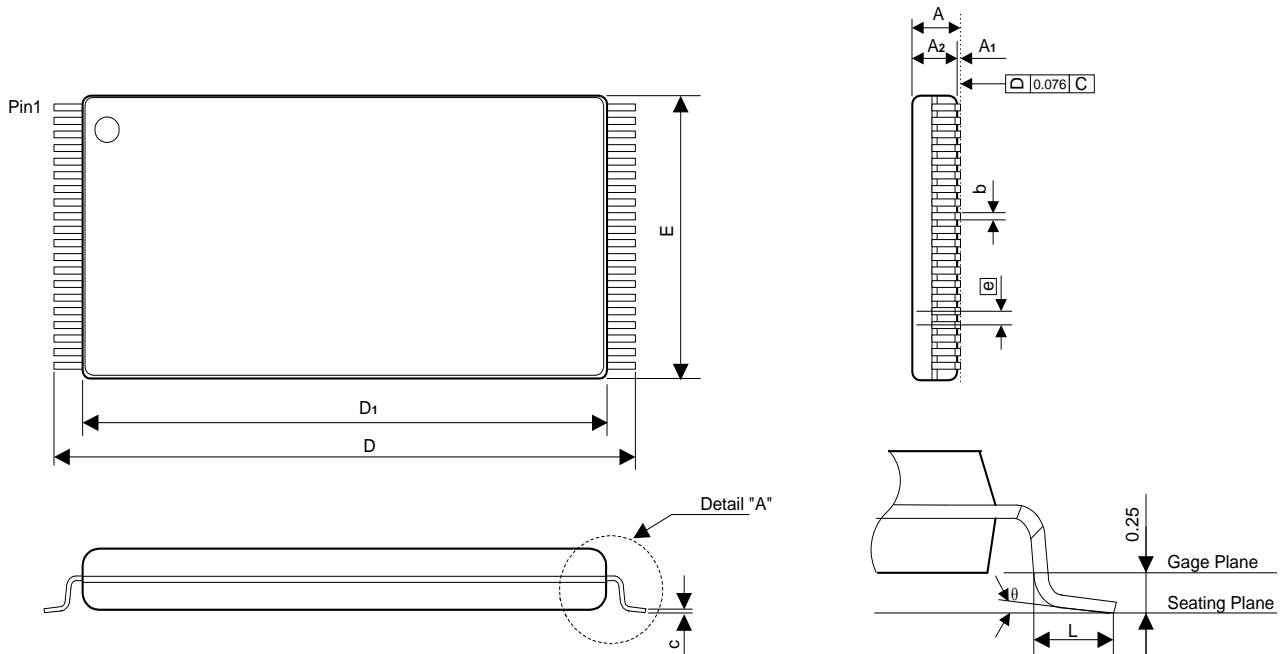

Symbol	Dimensions in inches			Dimensions in mm		
	Min	Nom	Max	Min	Nom	Max
A	-	-	0.047	-	-	1.20
A ₁	0.002	-	0.006	0.05	-	0.15
A ₂	0.037	0.039	0.041	0.95	1.00	1.05
b	0.0067	0.0087	0.0106	0.17	0.22	0.27
c	0.004	-	0.0083	0.10	-	0.21
E	0.394 BSC			10.00 BSC		
\square e	0.020 BSC			0.50 BSC		
D	0.787 BSC			20.00 BSC		
D ₁	0.724 BSC			18.40 BSC		
L	0.020	0.024	0.028	0.50	0.60	0.70
θ	0°	3°	5°	0°	3°	5°

Notes:

1. Dimension D₁ and E do not include mold flash.
2. The lead width dimension does not include dambar protrusion.
Total in excess of the lead width dimension at maximum material condition.
Dambar cannot be located on the lower radius of the foot.