

AMIC

FQV01 · FQV02 · FQV03 · FQV04 · FQV05

3.3 Volt Asynchronous x9 First-In/First-Out Queue

FlexQ™ Async

Document Title

3.3 Volt Asynchronous x9 First-In/First-Out Queue

Revision History

<u>Rev. No.</u>	<u>History</u>	<u>Issue Date</u>	<u>Remark</u>
C	Page 1, 2, 5, 6, 7, 8, 13, 14	August 1, 2003	
D	Add Pb-free package type on page 14	May 8, 2006	



3.3 Volt Asynchronous x9 First-In/First-Out Queue

FlexQ™ Async

3.3 Volt Asynchronous x9 First-In/First-Out Queue

Memory	Device
8,192 x 9	FQV05
4,096 x 9	FQV04
2,048 x 9	FQV03
1,024 x 9	FQV02
512 x 9	FQV01

Key Features:

- Industry leading First-In/First-Out Queues (up to 50MHz)
- Independent Write and Read cycle time
- Asynchronous and simultaneous read and write
- 3.3V power supply
- Fully expandable in both word depth and width
- Retransmit capability
- Full, Empty, and Half Full flag indicators
- Available packages: 32-pin Plastic Lead Chip Carrier (PLCC)
- All Pb-free (Lead-free) products are RoHS compliant
- (0°C to 70°C) Commercial operating temperature available for access time of 12ns and above
- (-40°C to 85°C) Industrial operating temperature available for access time of 25ns
- Pin-to-pin compatible with IDT (72V01, 72V02, 72V03, 72V04, 72V05)

Product Description:

AMIC's FlexQ™ Async FIFO offers industry leading 0.25um process technology and memory densities from 512 x 9 to 8,192 x 9. System designer has full flexibility of implementing deeper and wider queues using the depth and width expansion features. Full and Empty indicators allow easy handshaking between transmitters and receivers.

Independent Write and Read controls provide rate-matching capability. System designer can re-read data from the starting position by using Retransmit (RET). Retransmit allows reset of the read pointer to its initial position. Half Full flag (HALF) is available in the single device mode and width expansion mode, but not in depth expansion mode.

These FlexQ™ Async devices have low power consumption, hence minimizing system power requirements. In addition, industry standard 32 - pin PLCC are offered to save system board space.

These queues are ideal for applications such as data communication, telecommunication, graphics, multiprocessing, test equipment, medical systems, network switching, etc.

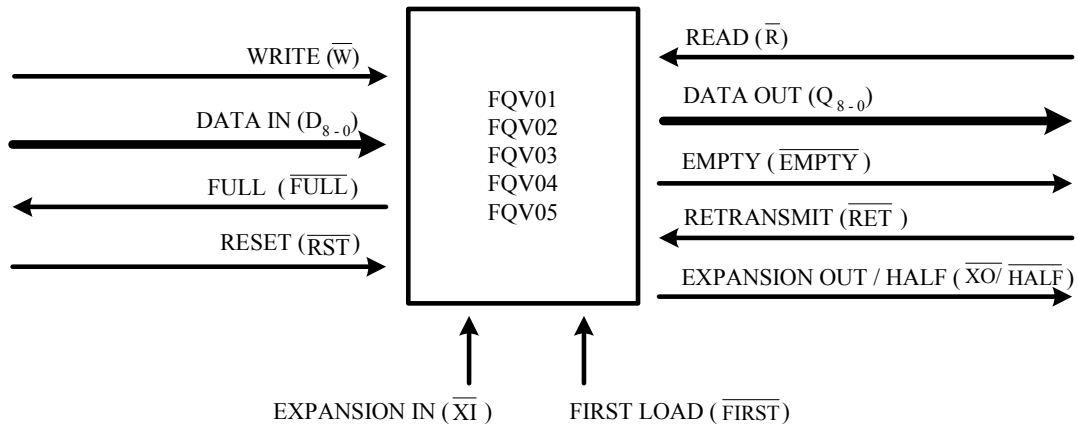

Figure 1. Device Configuration Signal Flow Diagram

Block Diagram of Single Asynchronous Queue
 8,192 x 9 / 4,096 x 9 / 2,048 x 9 / 1,024 x 9 / 512 x 9

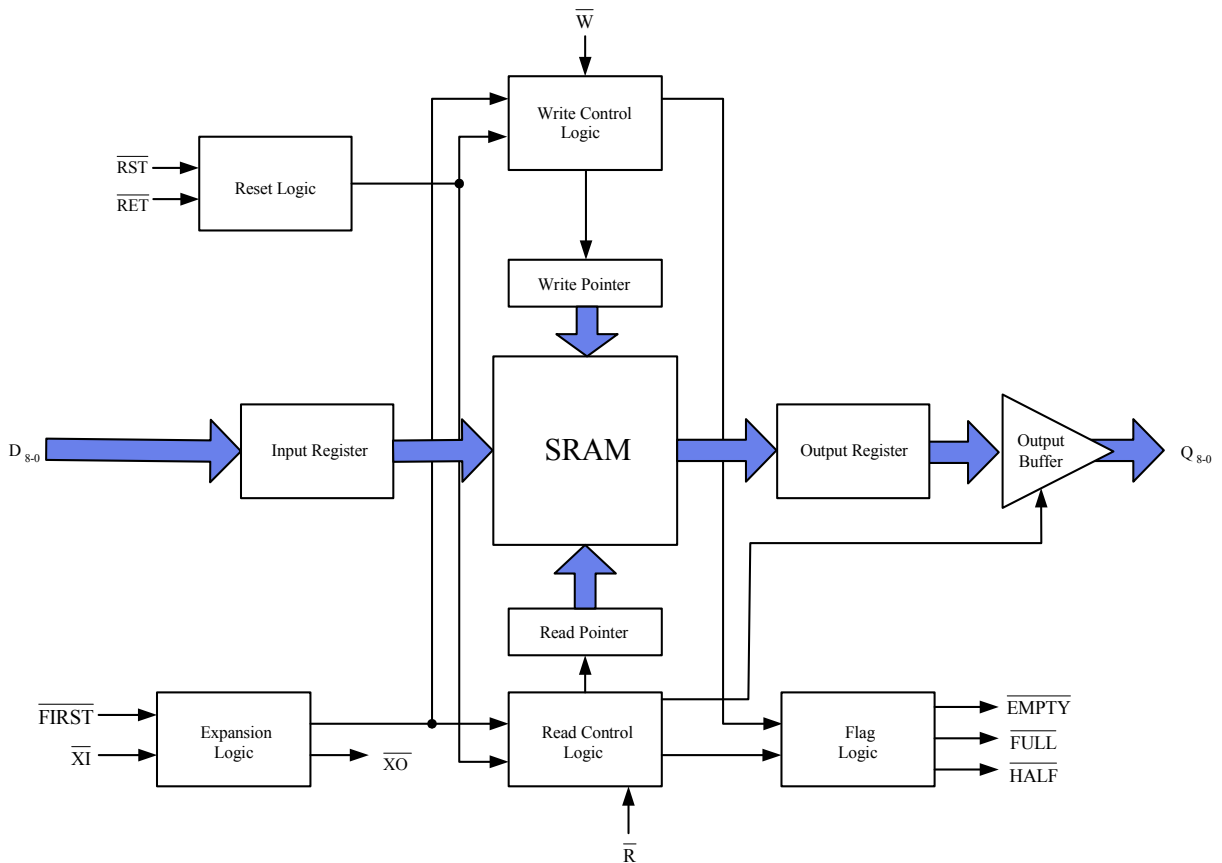
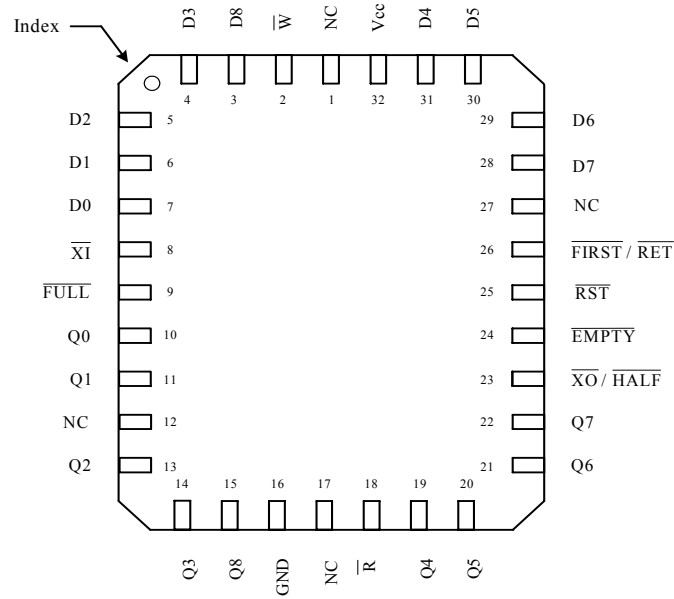

Figure 2. Device Architecture



PLCC - 32 (Drw No: J-01A; Order code: J)

Top View

Figure 3. Device Pin-Out

Pin #	Symbol	Name	Input/Output	Description
25	$\overline{\text{RST}}$	Reset	Input	Reset is required to initialize Write and Read pointers to the first position of the queue by setting $\overline{\text{RST}}$ low. $\overline{\text{FULL}}$ will go high; $\overline{\text{EMPTY}}$ will go low.
2	$\overline{\text{W}}$	Write	Input	Writes data into queue during low to high transitions of $\overline{\text{W}}$ if queue is not full yet.
3, 4, 5, 6, 7, 28, 29, 30, 31	D_{8-0}	Data Inputs	Input	9 - bit wide input data bus.
18	$\overline{\text{R}}$	Read	Input	Reads data from queue during high to low transitions of $\overline{\text{R}}$ if queue is not empty.
10, 11, 13, 14, 15, 19, 20, 21	Q_{8-0}	Data Output	Output	9 - bit wide output data bus.
26	FIRST / $\overline{\text{RET}}$	First Load/ Retransmit	Input	FIRST / $\overline{\text{RET}}$ is used differently depending on mode. In Depth Expansion Mode, the pin is grounded to indicate first load. In Single Device Mode, the pin acts as
8	$\overline{\text{XI}}$	Expansion In	Input	$\overline{\text{XI}}$ is used to indicate operations in different modes. When the pin is grounded, it indicates an operation in the Single Device Mode. When it is tied to V_{cc} , it indicates an operation in Depth Expansion Mode.
9	$\overline{\text{FULL}}$	Full Flag	Output	Queue is full when $\overline{\text{FULL}}$ goes low. This prohibits further writes into the queue. The assertion of $\overline{\text{FULL}}$ is synchronous to the falling edge of $\overline{\text{W}}$ and the deassertion is synchronous to the rising edge of $\overline{\text{R}}$.
24	$\overline{\text{EMPTY}}$	Empty Flag	Output	Queue is empty when $\overline{\text{EMPTY}}$ goes low. This prohibits further reads from the queue. The assertion of $\overline{\text{EMPTY}}$ is synchronous to the falling edge of $\overline{\text{R}}$ and the deassertion is synchronous to the rising edge of $\overline{\text{W}}$.
23	$\overline{\text{XO}}$ / HALF	Expansion Out / Half Full Flag	Output	$\overline{\text{XO}}$ / HALF is used differently depending on mode. In Depth Expansion Mode, $\overline{\text{XI}}$ is connected to the previous device's $\overline{\text{XO}}$ pin. When the previous device has reached the last location of memory, this pin will send pulses to the next device in the Daisy Chain. In Single Device Mode, when $\overline{\text{XI}}$ is grounded, this pin indicates queue is half-full.
32	V_{cc}	Power	N/A	3.3V power supply.
16	GND	Ground	N/A	0V Ground.
1, 12, 17, 27	NC	No Connection	N/A	No connection.

Table 1. Pin Descriptions

Symbol	Rating	Com'l & Ind'l	Unit
V _{TERM}	Terminal Voltage with respect to GND	-0.5 to +7	V
T _{STG}	Storage Temperature	-55 to +125	°C
I _{OUT}	DC Output Current	-50 to +50	mA

NOTES:

Absolute Max Ratings are for reference only. Permanent damage to the device may occur if extended period of operation is outside this range. Standard operation should fall within the Recommended Operating Conditions.

Table 2. Absolute Maximum Ratings

		FQV05, FQV04, FQV03, FQV02, FQV01						Unit
		Commercial t _A = 12ns, 25ns, 35ns			Industrial t _A = 25ns			
Symbol	Parameter	Min.	Typ.	Max.	Min.	Typ.	Max.	Unit
Recommended Operating Conditions								
V _{CC}	Supply Voltage Com'l/Ind'l	3.0	3.3	3.6	3.0	3.3	3.6	V
GND	Supply Voltage	0	0	0	0	0	0	V
V _{IH}	Input High Voltage Com'l/Ind'l	2.0	-	-	2.0	-	-	V
V _{IL}	Input Low Voltage Com'l/Ind'l	-	-	0.8	-	-	0.8	V
T _A	Operating Temperature	0	-	70	-40	-	85	°C
DC Electrical Characteristics								
I _{LI} ⁽¹⁾	Input Leakage Current (any input)	-10	-	10	-10	-	10	μA
I _{LO}	Output Leakage Current	-10	-	10	-10	-	10	μA
V _{OH}	Output Logic "1" Voltage, I _{OH} =-2mA	2.4	-	-	2.4	-	-	V
V _{OL}	Output Logic "0" Voltage, I _{OL} = 8mA	-	-	0.4	-	-	0.4	V
Power Consumption								
I _{CC1} ^(2,3,4)	Active Power Supply Current	-	-	50	-	-	50	mA
I _{CC2} ^(2,5)	Standby Current	-	-	5	-	-	5	mA
Capacitance at 1.0MHz Ambient Temperature (25°C)								
Symbol	Parameter	Conditions			Max.	Unit		
C _{IN} ⁽⁶⁾	Input Capacitance	V _{IN} = 0V			8	pF		
C _{OUT} ⁽⁶⁾	Output Capacitance	V _{OUT} = 0V			8	pF		

NOTES:

1. Measurement with 0.4<=V_{IN}<=V_{CC}
2. Tested with outputs open (I_{OUT}=0)
3. Tested at f=20MHz
4. Typical I_{CC1}=15+2*fs+0.02*CL*fc (in mA) with V_{CC}=3.3V, t_A=25°C, fs=WCLK frequency=RCLK frequency (in MHz, using TTL levels), data switching at fs/2, CL=Capacitive load (in PF)
5. All inputs = V_{CC}-0.2V or GND+0.2V and (R=W=RST=FIRST/RET=V_{IH})
6. Design simulated, not tested.

Table 3. DC Specifications

Symb	Parameter	Commercial & Industrial						Unit
		FQV05-12 FQV04-12 FQV03-12 FQV02-12 FQV01-12		FQV05-25 FQV04-25 FQV03-25 FQV02-25 FQV01-25		FQV05-35 FQV04-35 FQV03-35 FQV02-35 FQV01-35		
		Min.	Max	Min.	Max	Min.	Max	
f _s	Shift Frequency	-	40	-	28.5	-	22.2	MHz
t _{RC}	Read Cycle Time	25	-	35	-	45	-	ns
t _A	Access Time	-	15	-	25	-	35	ns
t _{RR}	Read Recovery Time	10	-	10	-	10	-	ns
t _{RPW}	Read Pulse Width	15	-	25	-	35	-	ns
t _{RLZ}	Read Pulse Low to Data Bus at Low Z ⁽¹⁾	3	-	3	-	3	-	ns
t _{WLZ}	Write Pulse High to Data Bus at Low Z ^(1,2)	5	-	5	-	5	-	ns
t _{DV}	Data Valid from Read Pulse High	5	-	5	-	5	-	ns
t _{RHZ}	Read Pulse High to Data Bus at High Z ⁽¹⁾	-	15	-	18	-	20	ns
t _{WC}	Write Cycle Time	25	-	35	-	45	-	ns
t _{WPW}	Write Pulse Width	15	-	25	-	35	-	ns
t _{WR}	Write Recovery Time	10	-	10	-	10	-	ns
t _{DS}	Data Set-up Time	11	-	15	-	18	-	ns
t _{DH}	Data Hold Time	0	-	0	-	0	-	ns
t _{RSTC}	Reset Cycle Time	25	-	35	-	45	-	ns
t _{RST}	Reset Pulse Width	15	-	25	-	35	-	ns
t _{RSTS}	Reset Set-up Time ⁽¹⁾	15	-	25	-	35	-	ns
t _{RSTR}	Reset Recovery Time	10	-	10	-	10	-	ns
t _{RETC}	Retransmit Cycle Time	25	-	35	-	45	-	ns
t _{RET}	Retransmit Pulse Width	15	-	25	-	35	-	ns
t _{RETS}	Retransmit Set-up Time ⁽¹⁾	15	-	25	-	35	-	ns
t _{RETR}	Retransmit Recovery Time	10	-	10	-	10	-	ns
t _{EFL}	Reset to Empty Flag Low	-	25	-	35	-	45	ns
t _{HFH}	Reset to Half-Full and Full Flag High	-	25	-	35	-	45	ns
t _{RETF}	Retransmit Low to Flags Valid	-	25	-	35	-	45	ns
t _{REMPY}	Read Low to Empty Flag Low	-	15	-	25	-	30	ns
t _{RFULL}	Read High to Full Flag High	-	15	-	25	-	30	ns
t _{RPE}	Read Pulse Width after Empty Flag High	15	-	25	-	35	-	ns
t _{WEMPTY}	Write High to Empty Flag High	-	15	-	25	-	30	ns
t _{WFULL}	Write Low to Full Flag Low	-	15	-	25	-	30	ns
t _{WHALF}	Write Low to Half-Full Flag Low	-	25	-	35	-	45	ns
t _{RHALF}	Read High to Half-Full Flag High	-	25	-	35	-	45	ns
t _{WPF}	Write Pulse Width after Full Flag High	15	-	25	-	35	-	ns
t _{XOL}	Read/Write to XO Low	-	15	-	25	-	35	ns
t _{XOH}	Read/Write to XO High	-	15	-	25	-	35	ns
t _{XI}	XT Pulse Width	15	-	25	-	35	-	ns
t _{XIR}	XT Recovery Time	10	-	10	-	10	-	ns
t _{XIS}	XT Set-up Time	10	-	10	-	10	-	ns

NOTES:

- Design simulated, not tested.
- Only applies to read data flow-through mode.

Table 4. AC Electrical Characteristics

Input Pulse Levels	GND to 3.0V
Input Rise/Fall Times	5ns
Input Timing Reference Levels	1.5V
Output Reference Levels	1.5V
Output Load	Refer to Figure 4

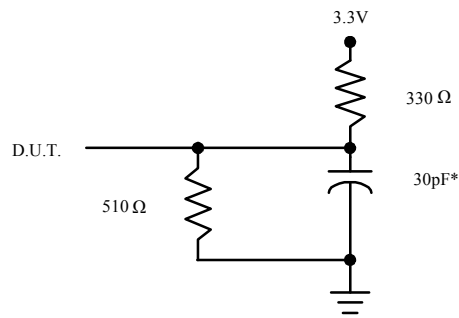
Table 5. AC Test Condition

Figure 4. Output Load

*Includes jig and scope capacitances.

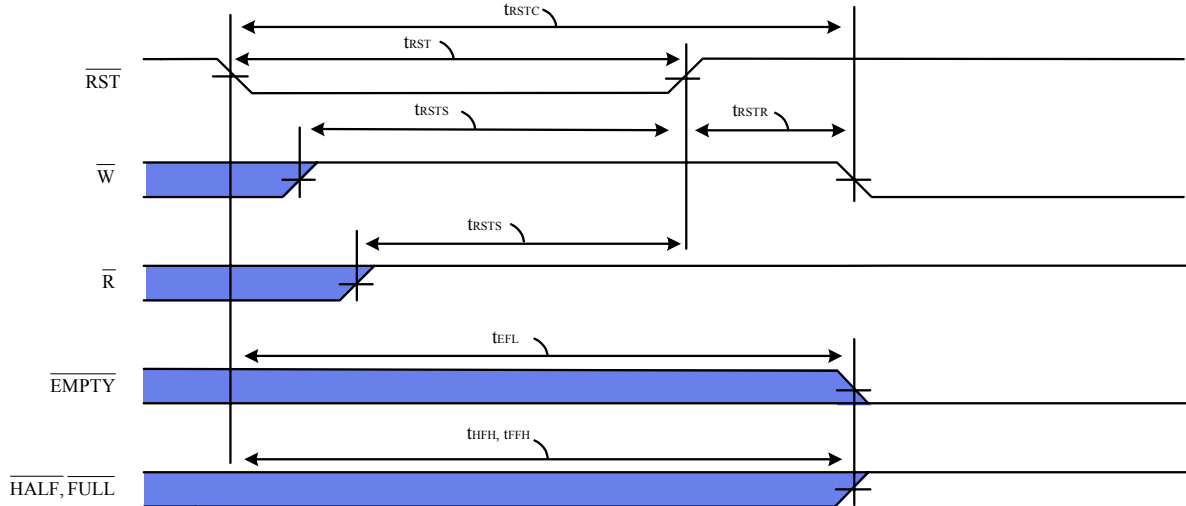
Timing Diagrams

NOTES:

1. EMPTY, FULL, and HALF may change status during Reset, but are valid at trSTC.
2. W and R = VIH near rising edge of RST.

Diagram 1. Reset Timing

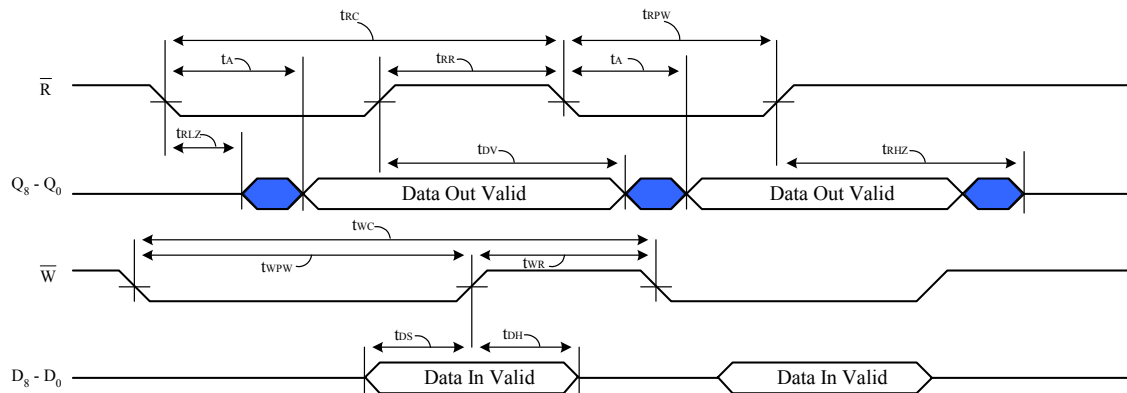
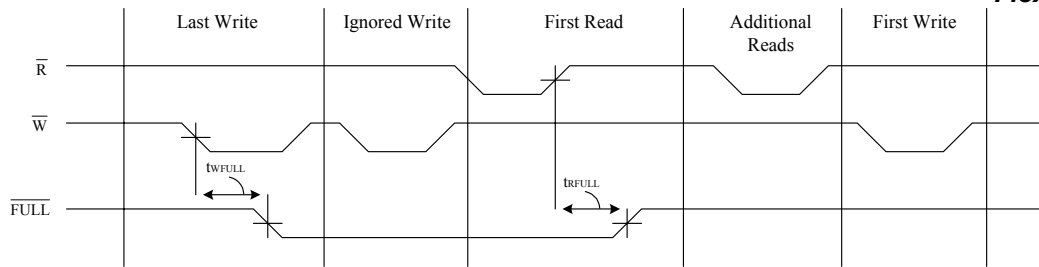
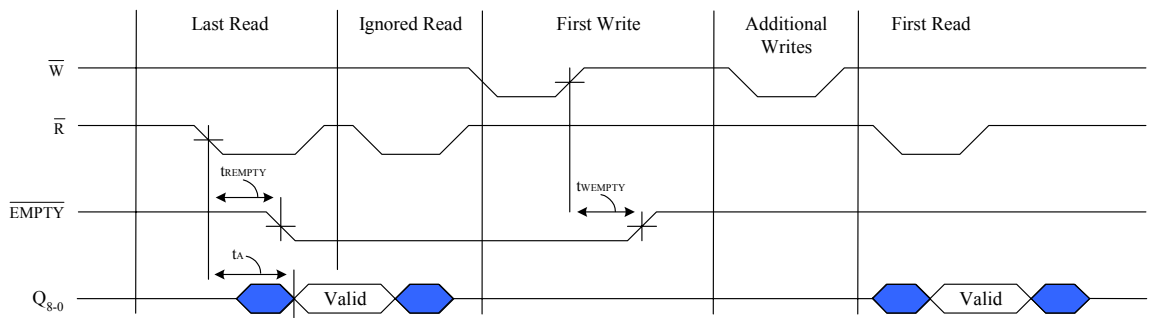
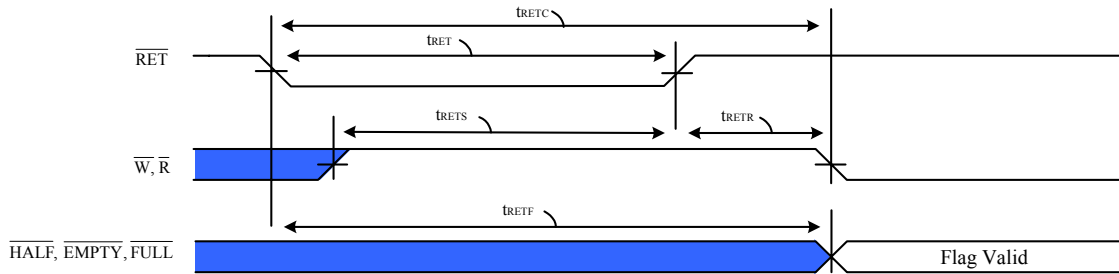
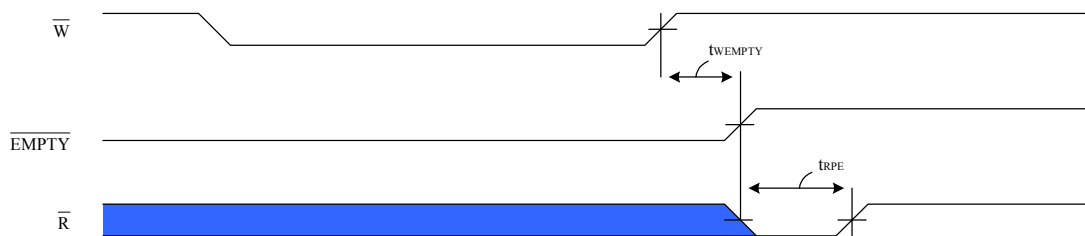
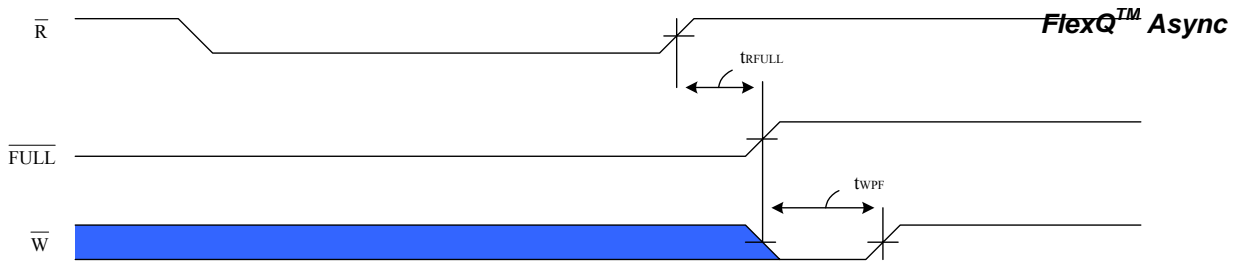
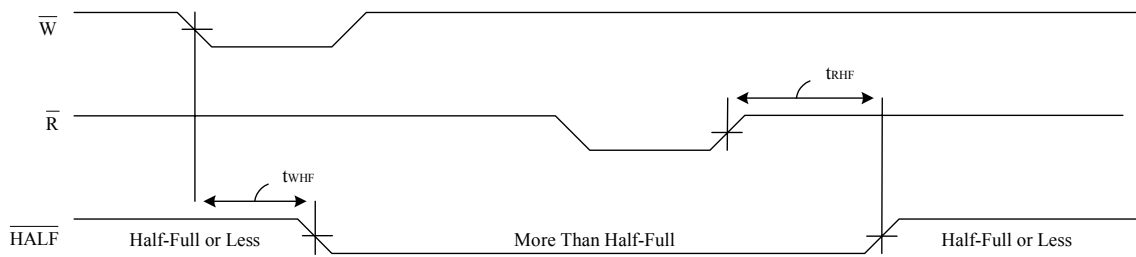
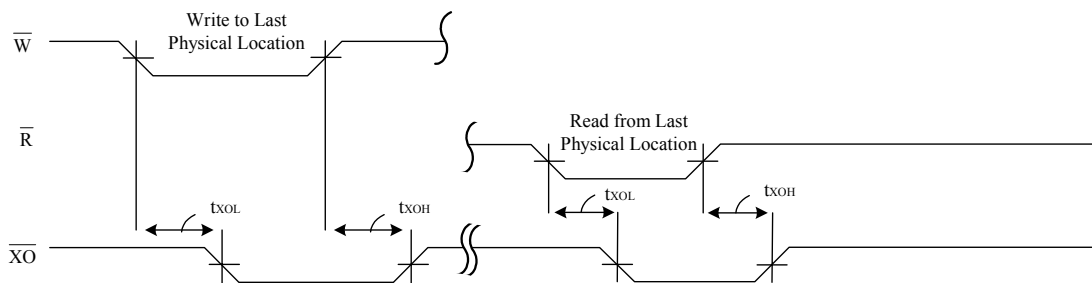
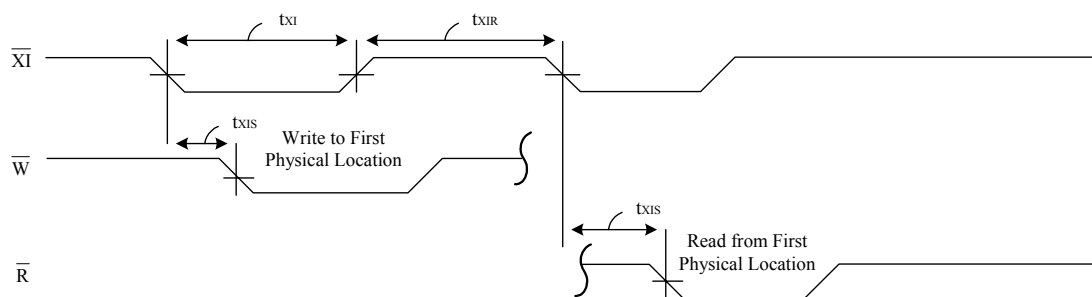

Diagram 2. Asynchronous Write and Read Operation

Diagram 3. Full Flag From Last Write to First Read

Diagram 4. Empty Flag From Last Read to First Write

Diagram 5. Retransmit

Diagram 6. Minimum Timing for an Empty Flag Coincident Read Pulse

Diagram 7. Minimum Timing for a Full Flag Coincident Write Pulse

Diagram 8. Half-Full Flag Timing

Diagram 9. Expansion Out

Diagram 10. Expansion In

Operating Modes

Single Device Mode: When application requirements are for 256/512/1,024/2,048/4,096/8,192 words or less, a single device may be used. These devices are in Single Device Mode when Expansion In (\overline{XI}) is grounded.

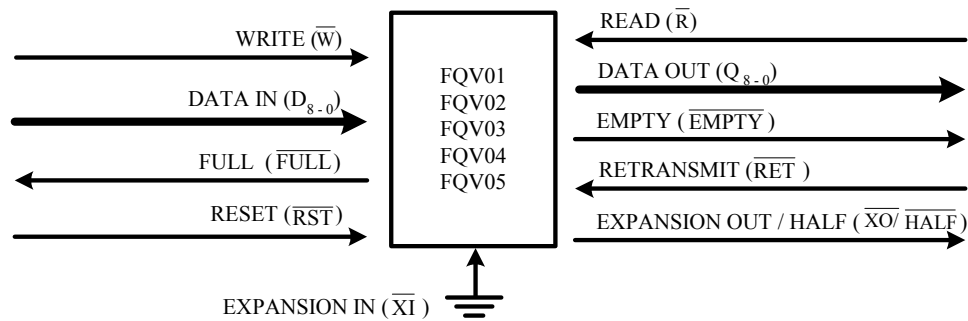

Figure 5. Single Device Mode

Depth Expansion Mode: When application requirements are greater than 256/512/1,024/2,048/4,096/8,192 words, multiple devices may be used for Depth Expansion. These devices are in Depth Expansion Mode when the following conditions are met:

1. The first device's First Load (\overline{FIRST}) pin must be grounded.
2. All other devices' First Load (\overline{FIRST}) pin must be tied to HIGH
3. All devices' Expansion Out (\overline{XO}) pin must be tied to the next devices' Expansion In (\overline{XI}) pin.
4. Retransmit (\overline{RET}) and Half-Full Flag (\overline{HALF}) are non-functional in Depth Expansion Mode.
5. An external logic is required to generate a composite Full Flag (\overline{FULL}) and Empty Flag (\overline{EMPTY}). This requires the ORing of all Empty and Full Flags.

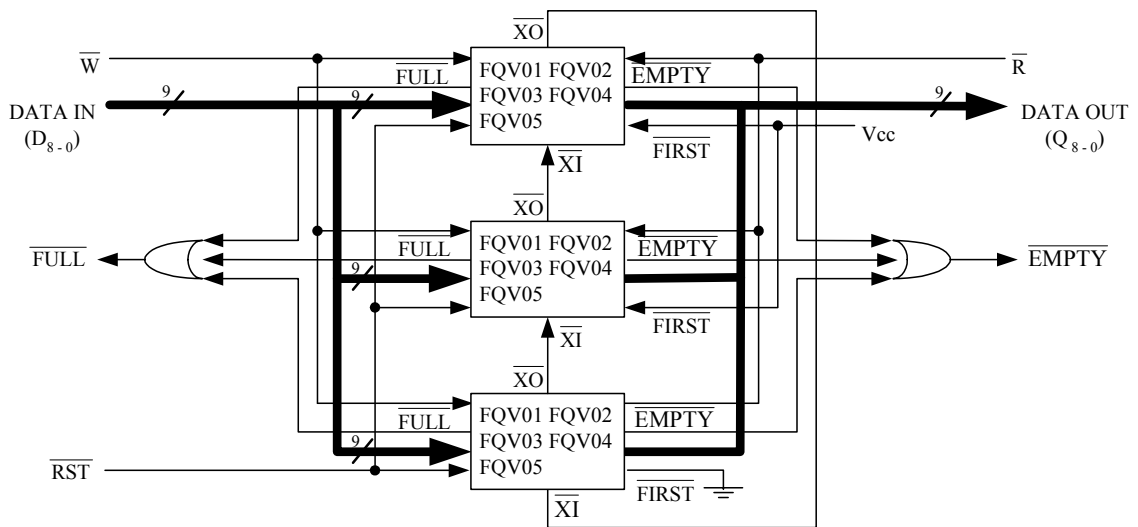

Figure 6. Depth Expansion Mode

Usage Modes

Width Expansion Mode: When applications require increased word width, multiple devices may be used for Width Expansion Mode. These devices are in Width Expansion Mode when the same signals from multiple devices are connected. Any word width may be achieved by connecting additional devices. Status flags are functional for any one device.

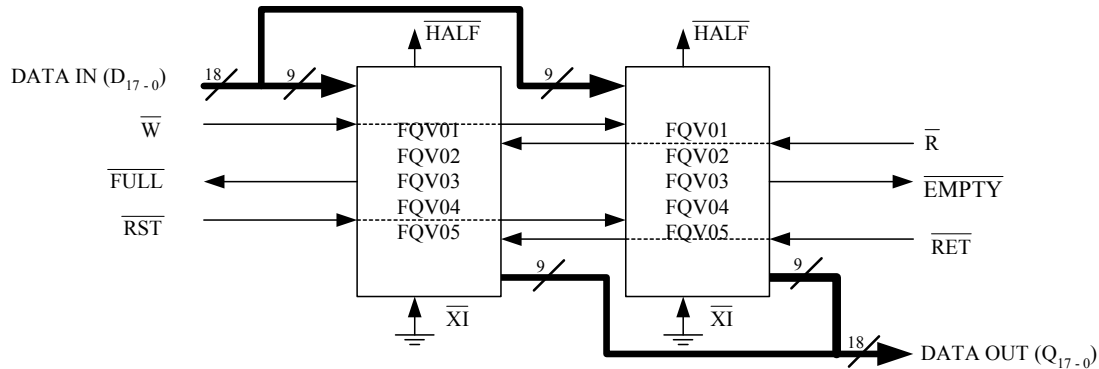

Figure 7. Width Expansion Mode

Bidirectional Mode: When applications require data buffering between two systems that are capable of Read and Write operations, a pair of devices may be used for Bidirectional Mode. Both Depth Expansion and Width Expansion may be used in this mode.

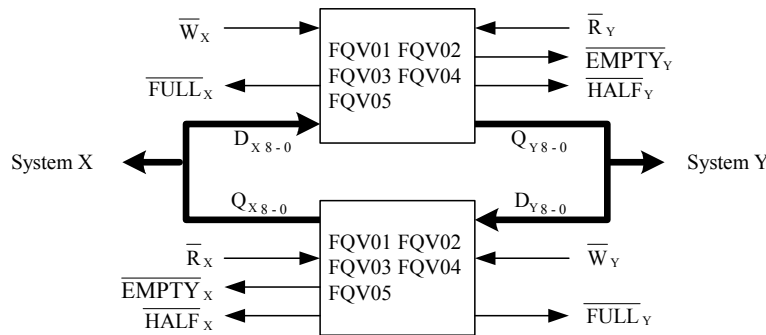
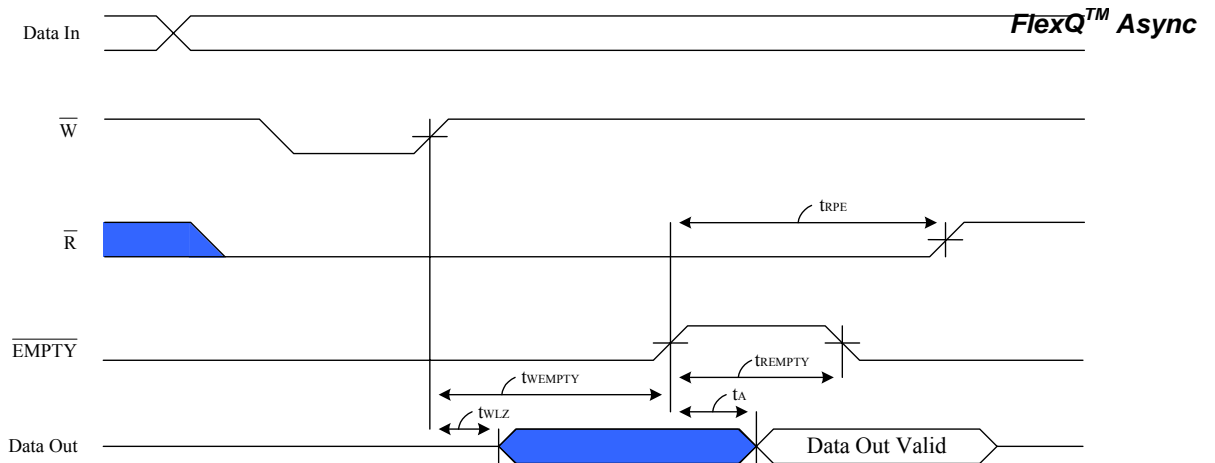
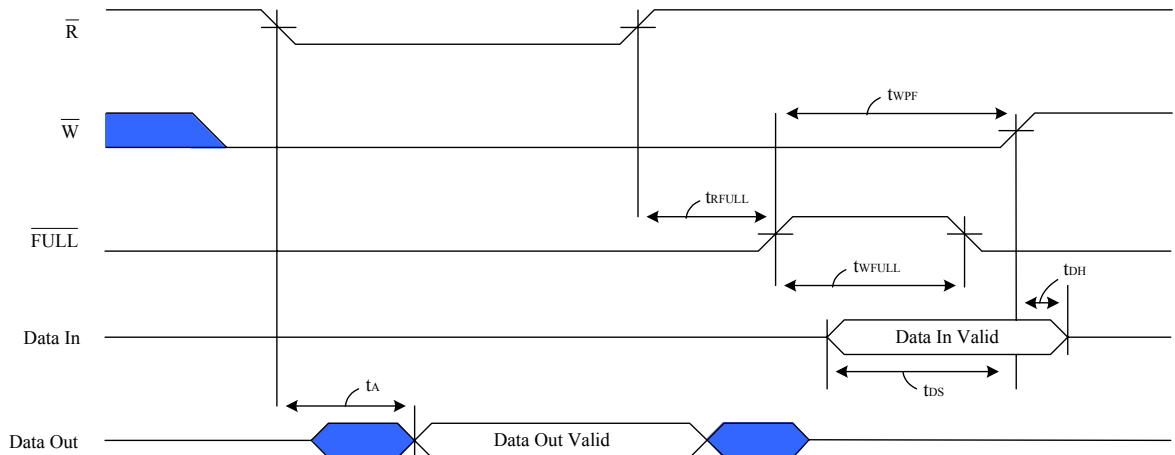
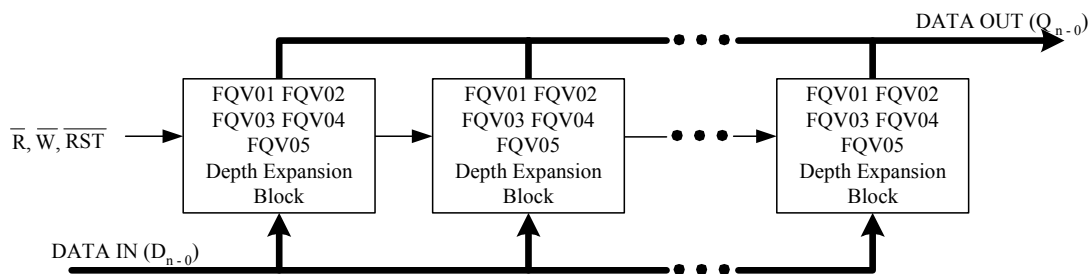

Figure 8. Bidirectional Mode

Data Flow-Through Mode: There are two types of flow-through modes, read flow-through and write flow-through. In the read flow-through mode, the device allows a single word to be read after one word of data has been written into an empty FIFO. The data is enabled on the bus after the rising edge of \overline{W} , and remains on the bus until \overline{R} goes from Low to High. Then the bus goes into a three-state mode. \overline{EMPTY} will have a pulse showing temporary deassertion and then would be asserted. In the write flow-through mode, the device allows a single word to be written after one word of data has been read from a full FIFO. \overline{R} causes \overline{FULL} to be deasserted but a Low \overline{W} causes it to be asserted again for the new data word. The new word goes into the FIFO on the rising edge of \overline{W} . \overline{W} must be toggled when \overline{FULL} is not asserted to write new data into the FIFO and to increment the write pointer.

Diagram 11. Read Data Flow-Through Mode

Diagram 12. Write Data Flow-Through Mode

Compound Expansion Mode: Compound Expansion Mode is a combination of Depth and Width Expansion Modes to achieve large FIFO arrays.

Figure 9. Compound Expansion Mode



Order Information:

AMIC Device Family	Device Type	Power	Speed (ns)*	Package**	Temperature Range	Material
<u>XX</u> FQV	<u>XX</u> 05 (8,192 x 9) 04 (4,096 x 9) 03 (2,048 x 9) 02 (1,024 x 9) 01 (512 x 9)	<u>X</u> Low	<u>XX</u> 12 – 50 MHz 25 – 29 MHz 35 – 22 MHz	<u>X</u> J	<u>X</u> Blank – Commercial (0°C to 70°C) I – Industrial (-40° to 85°C)†	<u>X</u> Blank – Normal material -F – Pb-Free material

*Speed – Slower speeds available upon request.

**Package – 32 - pin Plastic Lead Chip Carrier (PLCC)

†Temperature – Industrial only offered in 25ns

Example:

FQV05L12J (8k x 9, 12ns, PLCC, Commercial temp, Normal material)
 FQV05L12J-F (8k x 9, 12ns, PLCC, Commercial temp, Pb-Free material)