

**AMIC**

**LP62S1024B-I Series**

**128K X 8 BIT LOW VOLTAGE CMOS SRAM**

---

**Document Title**

**128K X 8 BIT LOW VOLTAGE CMOS SRAM**

**Revision History**

| <b><u>Rev. No.</u></b> | <b><u>History</u></b>                                    | <b><u>Issue Date</u></b> | <b><u>Remark</u></b> |
|------------------------|--|--------------------------|----------------------|
| 0.0                    | Initial issue  | May 30, 2002             | Preliminary          |
| 0.1                    | Add 32L Pb-Free TSSOP package type                       | October 2, 2002          |                      |
| 1.0                    | Final version release                                    | July 18, 2003            | Final                |
| 1.1                    | Change IccDR1, IccDR2 (max.) from 3 $\mu$ A to 1 $\mu$ A | June 29, 2004            |                      |
| 1.2                    | Add Pb-Free package type for all parts                   | August 9, 2004           |                      |
| 1.3                    | Change Data Retention Spec. from 2V to 1.5V              | January 23, 2007         |                      |
| 1.4                    | Add access time 45ns grade                               | December 26, 2008        |                      |

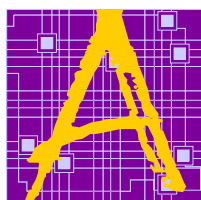

**AMIC**

## LP62S1024B-I Series

### 128K X 8 BIT LOW VOLTAGE CMOS SRAM

#### Features

- Power supply range: 2.7V to 3.6V
- Access times: 45/55/70 ns (max.)
- Current:
  - Very low power version: Operating: 30mA(max.)
  - Standby: 5uA (max.)
- Full static operation, no clock or refreshing required
- All inputs and outputs are directly TTL-compatible
- Common I/O using three-state output
- Output enable and two chip enable inputs for easy application
- Data retention voltage: 1.5V (min.)
- Available in 32-pin SOP, TSOP, TSSOP (8 X 13.4mm) forward type and 36-pin CSP packages
- All Pb-free (Lead-free) products are RoHS compliant

#### General Description

The LP62S1024B-I is a low operating current 1,048,576-bit static random access memory organized as 131,072 words by 8 bits and operates on a low power voltage: 2.7V to 3.6V. It is built using AMIC's high performance CMOS process. Inputs and three-state outputs are TTL compatible and allow for direct interfacing with common system bus structures. Two chip enable inputs are provided for POWER-DOWN and device enable and an output enable input is included for easy interfacing. Data retention is guaranteed at a power supply voltage as low as 1.5V.

#### Product Family

| Product Family | Operating Temperature | VCC Range | Speed          | Power Dissipation                         |                                   |                                     | Package Type                                 |
|----------------|-----------------------|-----------|----------------|---|-----------------------------------|-------------------------------------|--|
|                |                       |           |                | Data Retention (I <sub>CCDR</sub> , Typ.) | Standby (I <sub>SB1</sub> , Typ.) | Operating (I <sub>CC2</sub> , Typ.) |  |
| LP62S1024B     | -40°C ~ +85°C         | 2.7V~3.6V | 45ns/55ns/70ns | 0.05μA                                    | 0.08μA                            | 1.5mA                               | 32L SOP<br>32L TSOP<br>32L TSSOP<br>36B μBGA |

1. Typical values are measured at VCC = 3.0V, T<sub>A</sub> = 25°C and not 100% tested.
2. Data retention current VCC = 1.5V.

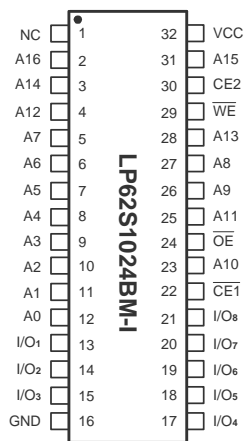
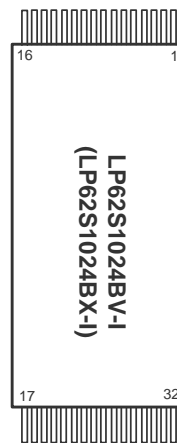
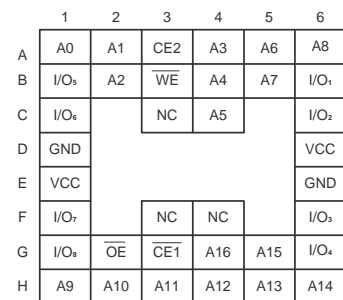
**Pin Configurations**
**■ SOP**

**■ TSOP/TSSOP**

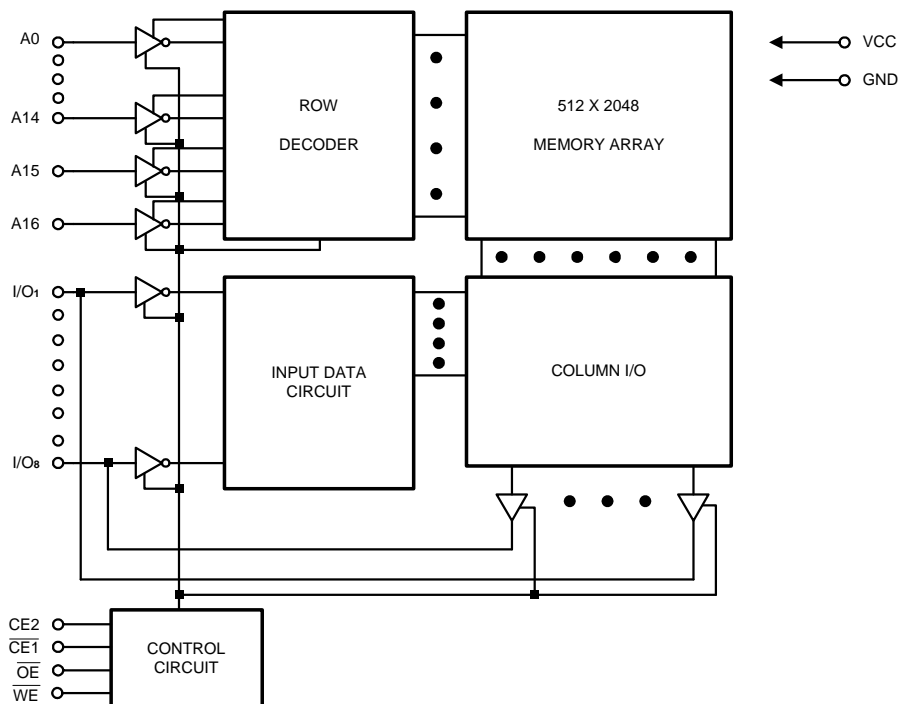
**■ CSP (Chip Size Package)**
**36-pin Top View**

|          |     |    |    |     |                  |                  |                  |     |                  |                  |                  |                  |                  |     |     |    |
|----------|-----|----|----|-----|------------------|------------------|------------------|-----|------------------|------------------|------------------|------------------|------------------|-----|-----|----|
| Pin No.  | 1   | 2  | 3  | 4   | 5                | 6                | 7                | 8   | 9                | 10               | 11               | 12               | 13               | 14  | 15  | 16 |
| Pin Name | A11 | A9 | A8 | A13 | WE               | CE2              | A15              | VCC | NC               | A16              | A14              | A12              | A7               | A6  | A5  | A4 |
| Pin No.  | 17  | 18 | 19 | 20  | 21               | 22               | 23               | 24  | 25               | 26               | 27               | 28               | 29               | 30  | 31  | 32 |
| Pin Name | A3  | A2 | A1 | A0  | I/O <sub>1</sub> | I/O <sub>2</sub> | I/O <sub>3</sub> | GND | I/O <sub>4</sub> | I/O <sub>5</sub> | I/O <sub>6</sub> | I/O <sub>7</sub> | I/O <sub>8</sub> | CE1 | A10 | OE |

**Block Diagram**

**Pin Descriptions - SOP**

| Pin No.                    | Symbol                              | Description        |
|----------------------------|-------------------------------------|--------------------|
| 1                          | NC                                  | No Connection      |
| 2 - 12, 23,<br>25 - 28, 31 | A0 - A16                            | Address Inputs     |
| 13 - 15,<br>17 - 21        | I/O <sub>1</sub> - I/O <sub>8</sub> | Data Input/Outputs |
| 16                         | GND                                 | Ground             |
| 22                         | $\overline{CE1}$                    | Chip Enable        |
| 24                         | $\overline{OE}$                     | Output Enable      |
| 29                         | $\overline{WE}$                     | Write Enable       |
| 30                         | CE2                                 | Chip Enable        |
| 32                         | VCC                                 | Power Supply       |

**Pin Description – TSOP/TSSOP**

| Pin No.                  | Symbol                              | Description        |
|--------------------------|-------------------------------------|--------------------|
| 1 - 4, 7,<br>10 - 20, 31 | A0 - A16                            | Address Inputs     |
| 5                        | $\overline{WE}$                     | Write Enable       |
| 6                        | CE2                                 | Chip Enable        |
| 8                        | VCC                                 | Power Supply       |
| 9                        | NC                                  | No Connection      |
| 21 - 23,<br>25 - 29      | I/O <sub>1</sub> - I/O <sub>8</sub> | Data Input/Outputs |
| 24                       | GND                                 | Ground             |
| 30                       | $\overline{CE1}$                    | Chip Enable        |
| 32                       | $\overline{OE}$                     | Output Enable      |

**Pin Description - CSP**

| Symbol           | Description    | Symbol                              | Description       |
|------------------|----------------|-------------------------------------|-------------------|
| A0 - A16         | Address Inputs | NC                                  | No Connection     |
| $\overline{WE}$  | Write Enable   | I/O <sub>1</sub> - I/O <sub>8</sub> | Data Input/Output |
| $\overline{OE}$  | Output Enable  | VCC                                 | Power Supply      |
| $\overline{CE1}$ | Chip Enable    | GND                                 | Ground            |
| CE2              | Chip Enable    | --                                  | --                |

**Recommended DC Operating Conditions**

 (T<sub>A</sub> = -40°C to +85°C)

| Symbol          | Parameter          | Min. | Typ. | Max.      | Unit |
|-----------------|--------------------|------|------|-----------|------|
| VCC             | Supply Voltage     | 2.7  | 3.0  | 3.6       | V    |
| GND             | Ground             | 0    | 0    | 0         | V    |
| V <sub>IH</sub> | Input High Voltage | 2.2  | -    | VCC + 0.3 | V    |
| V <sub>IL</sub> | Input Low Voltage  | -0.3 | -    | +0.6      | V    |
| C <sub>L</sub>  | Output Load        | -    | -    | 30        | pF   |
| TTL             | Output Load        | -    | -    | 1         | -    |

**Absolute Maximum Ratings\***

VCC to GND .....-0.5V to +4.6V  
 IN, IN/OUT Volt to GND ..... -0.5V to VCC +0.5V  
 Operating Temperature, T<sub>opr</sub> ..... -40°C to +85°C  
 Storage Temperature, T<sub>stg</sub> ..... -55°C to +125°C  
 Temperature Under Bias, T<sub>bias</sub> ..... -40°C to +85°C  
 Power Dissipation, P<sub>r</sub> ..... 0.7W

**\*Comments**

Stresses above those listed under "Absolute Maximum Ratings" may cause permanent damage to this device. These are stress ratings only. Functional operation of this device at these or any other conditions above those indicated in the operational sections of this specification is not implied or intended. Exposure to the absolute maximum rating conditions for extended periods may affect device reliability.

**DC Electrical Characteristics** (T<sub>A</sub> = -40°C to +85°C, VCC = 2.7V to 3.6V, GND = 0V)

| Symbol           | Parameter                    | LP62S1024B-45LLI/55LLI/70LLI |      | Unit | Conditions  |
|------------------|------------------------------|------------------------------|------|------|---|
|                  |                              | Min.                         | Max. |      |   |
| I <sub>LI</sub>  | Input Leakage Current        | -                            | 1    | μA   | V <sub>IN</sub> = GND to VCC  |
| I <sub>LO</sub>  | Output Leakage Current       | -                            | 1    | μA   | $\overline{CE1} = V_{IH}$ or $CE2 = V_{IL}$<br>or $\overline{OE} = V_{IH}$ or $\overline{WE} = V_{IL}$<br>V <sub>I/O</sub> = GND to VCC |
| I <sub>CC</sub>  | Active Power Supply Current  | -                            | 3    | mA   | $\overline{CE1} = V_{IL}$ , CE2 = V <sub>IH</sub><br>I <sub>I/O</sub> = 0mA   |
| I <sub>CC1</sub> | Dynamic Operating Current    | -                            | 30   | mA   | Min. Cycle, Duty = 100%<br>$\overline{CE1} = V_{IL}$ , CE2 = V <sub>IH</sub><br>I <sub>I/O</sub> = 0mA                                  |
| I <sub>CC2</sub> |                              | -                            | 3    | mA   | $\overline{CE1} = V_{IL}$ , CE2 = V <sub>IH</sub><br>V <sub>IH</sub> = VCC, V <sub>IL</sub> = 0V<br>f = 1 MHz, I <sub>I/O</sub> = 0mA   |
| I <sub>SB</sub>  | Standby Power Supply Current | -                            | 0.5  | mA   | VCC ≤ 3.3V, $\overline{CE1} = V_{IH}$ or CE2 = V <sub>IL</sub>  |
| I <sub>SB1</sub> |                              | -                            | 5    | μA   | VCC ≤ 3.3V, $\overline{CE1} \geq VCC - 0.2V$ or<br>CE2 ≤ 0.2V, V <sub>IN</sub> ≥ 0V   |
| V <sub>OL</sub>  | Output Low Voltage           | -                            | 0.4  | V    | I <sub>OL</sub> = 2.1mA   |
| V <sub>OH</sub>  | Output High Voltage          | 2.2                          | -    | V    | I <sub>OH</sub> = -1.0mA  |

**Truth Table**

| Mode           | $\overline{CE1}$ | CE2 | $\overline{OE}$ | $\overline{WE}$ | I/O Operation    | Supply Current             |
|----------------|------------------|-----|-----------------|-----------------|------------------|----------------------------|
| Standby        | H                | X   | X               | X               | High Z           | $I_{SB}, I_{SB1}$          |
|                | X                | L   | X               | X               | High Z           | $I_{SB}, I_{SB1}$          |
| Output Disable | L                | H   | H               | H               | High Z           | $I_{CC}, I_{CC1}, I_{CC2}$ |
| Read           | L                | H   | L               | H               | D <sub>OUT</sub> | $I_{CC}, I_{CC1}, I_{CC2}$ |
| Write          | L                | H   | X               | L               | D <sub>IN</sub>  | $I_{CC}, I_{CC1}, I_{CC2}$ |

Note: X = H or L

**Capacitance** ( $T_A = 25^\circ\text{C}$ ,  $f = 1.0\text{MHz}$ )

| Symbol     | Parameter                | Min. | Max. | Unit | Conditions    |
|------------|--------------------------|------|------|------|---------------|
| $C_{IN}^*$ | Input Capacitance        |      | 6    | pF   | $V_{IN} = 0V$ |
| $C_{IO}^*$ | Input/Output Capacitance |      | 8    | pF   | $V_{IO} = 0V$ |

\* These parameters are sampled and not 100% tested.

**AC Characteristics** ( $T_A = -40^{\circ}\text{C}$  to  $+85^{\circ}\text{C}$ ,  $V_{CC} = 2.7\text{V}$  to  $3.6\text{V}$ )

| Symbol            | Parameter                          | LP62S1024B-45LLI        |      | LP62S1024B-55LLI |      | LP62S1024B-70LLI |      | Unit |    |
|-------------------|------------------------------------|-------------------------|------|------------------|------|------------------|------|------|----|
|                   |                                    | Min.                    | Max. | Min.             | Max. | Min.             | Max. |      |    |
| Read Cycle        |                                    |                         |      |                  |      |                  |      |      |    |
| t <sub>RC</sub>   | Read Cycle Time                    | 45                      | -    | 55               | -    | 70               | -    | ns   |    |
| t <sub>AA</sub>   | Address Access Time                | -                       | 45   | -                | 55   | -                | 70   | ns   |    |
| t <sub>ACE1</sub> | Chip Enable Access Time            | $\overline{\text{CE1}}$ | -    | 45               | -    | 55               | -    | 70   | ns |
| t <sub>ACE2</sub> |                                    | CE2                     | -    | 45               | -    | 55               | -    | 70   | ns |
| t <sub>OE</sub>   | Output Enable to Output Valid      | -                       | 20   | -                | 30   | -                | 35   | ns   |    |
| t <sub>CLZ1</sub> | Chip Enable to Output in Low Z     | $\overline{\text{CE1}}$ | 5    | -                | 10   | -                | 10   | -    | ns |
| t <sub>CLZ2</sub> |                                    | CE2                     | 5    | -                | 10   | -                | 10   | -    | ns |
| t <sub>OLZ</sub>  | Output Enable to Output in Low Z   | 5                       | -    | 5                | -    | 5                | -    | ns   |    |
| t <sub>CHZ1</sub> | Chip Disable to Output in High Z   | $\overline{\text{CE1}}$ | 0    | 15               | 0    | 20               | 0    | 25   | ns |
| t <sub>CHZ2</sub> |                                    | CE2                     | 0    | 15               | 0    | 20               | 0    | 25   | ns |
| t <sub>OHZ</sub>  | Output Disable to Output in High Z | 0                       | 15   | 0                | 20   | 0                | 25   | ns   |    |
| t <sub>OH</sub>   | Output Hold from Address Change    | 5                       | -    | 5                | -    | 10               | -    | ns   |    |
| Write Cycle       |                                    |                         |      |                  |      |                  |      |      |    |
| t <sub>WC</sub>   | Write Cycle Time                   | 45                      | -    | 55               | -    | 70               | -    | ns   |    |
| t <sub>CW</sub>   | Chip Enable to End of Write        | 35                      | -    | 50               | -    | 60               | -    | ns   |    |
| t <sub>AS</sub>   | Address Setup Time                 | 0                       | -    | 0                | -    | 0                | -    | ns   |    |
| t <sub>AW</sub>   | Address Valid to End of Write      | 35                      | -    | 50               | -    | 60               | -    | ns   |    |
| t <sub>WP</sub>   | Write Pulse Width                  | 35                      | -    | 40               | -    | 50               | -    | ns   |    |
| t <sub>WR</sub>   | Write Recovery Time                | 0                       | -    | 0                | -    | 0                | -    | ns   |    |
| t <sub>WHZ</sub>  | Write to Output in High Z          | 0                       | 20   | 0                | 25   | 0                | 25   | ns   |    |
| t <sub>DW</sub>   | Data to Write Time Overlap         | 20                      | -    | 25               | -    | 30               | -    | ns   |    |
| t <sub>DH</sub>   | Data Hold from Write Time          | 0                       | -    | 0                | -    | 0                | -    | ns   |    |
| t <sub>OW</sub>   | Output Active from End of Write    | 5                       | -    | 5                | -    | 5                | -    | ns   |    |

Notes: t<sub>CHZ1</sub>, t<sub>CHZ2</sub>, t<sub>OHZ</sub>, and t<sub>WHZ</sub> are defined as the time at which the outputs achieve the open circuit condition and are not referred to output voltage levels.

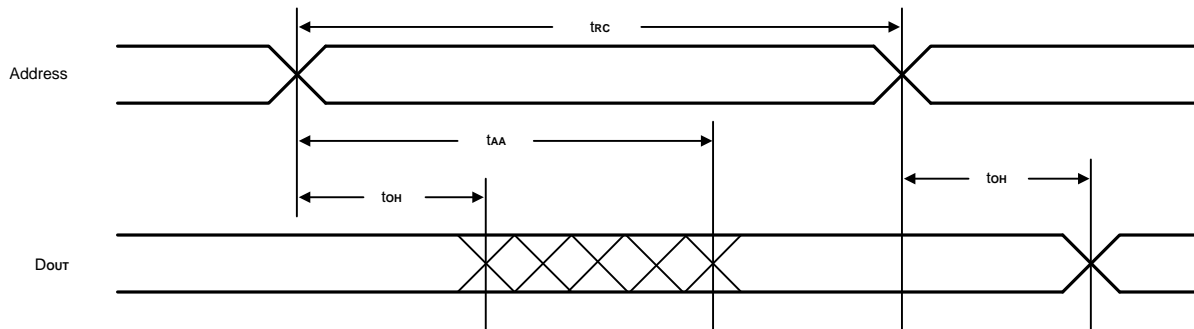
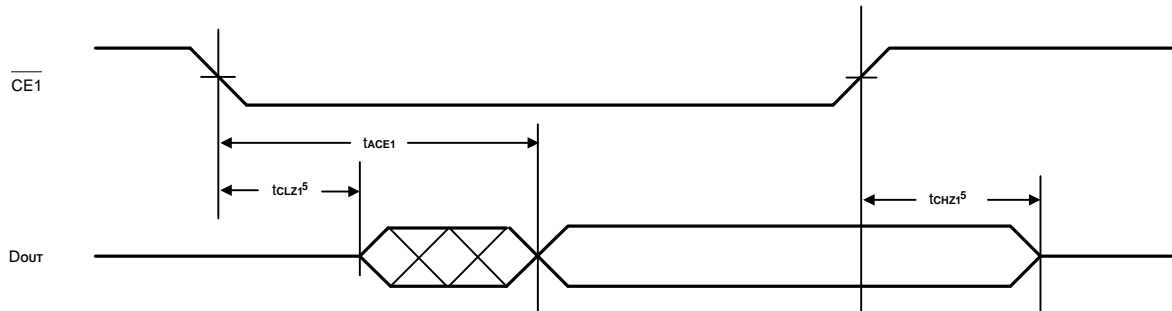
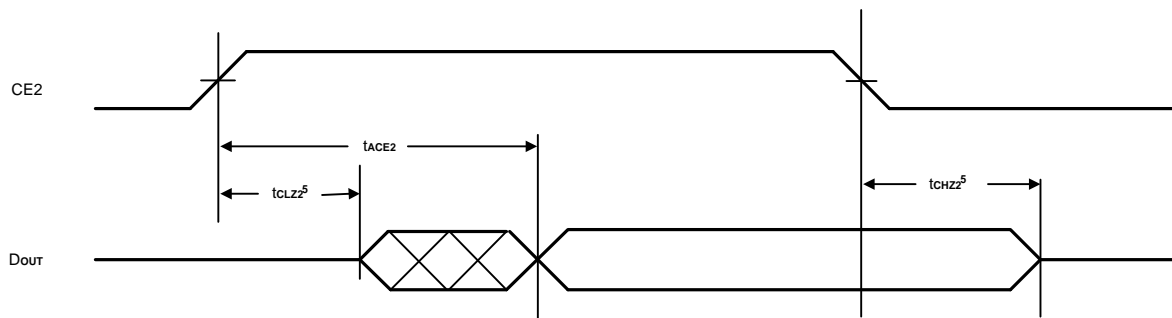
**Timing Waveforms**
**Read Cycle 1 (1, 2, 4)**

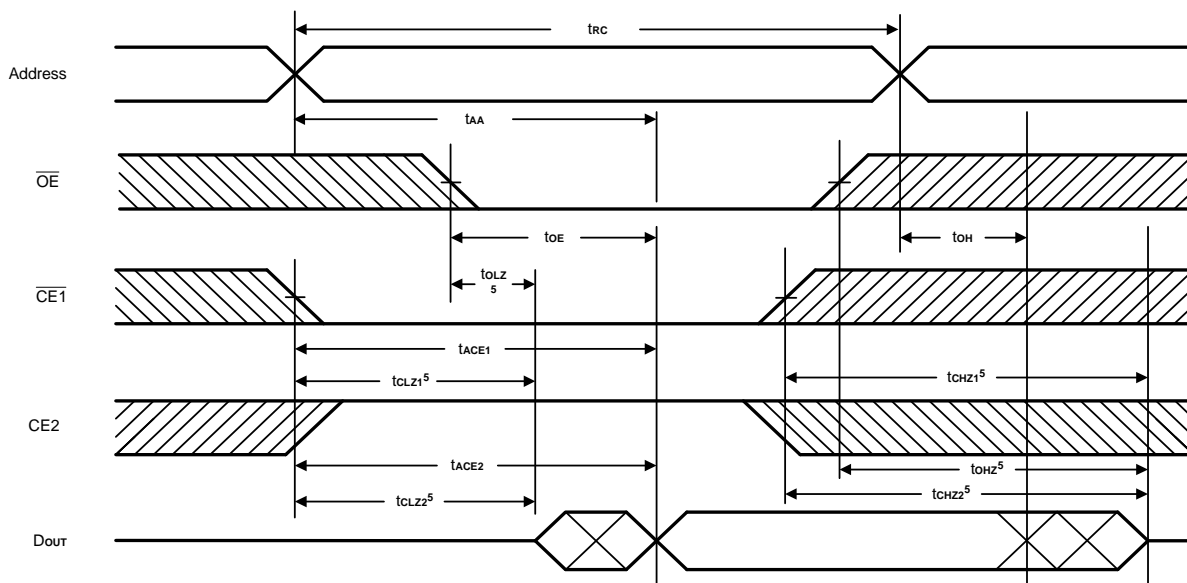
**Read Cycle 2 (1, 3, 4, 6)**

**Read Cycle 3 (1, 4, 7, 8)**

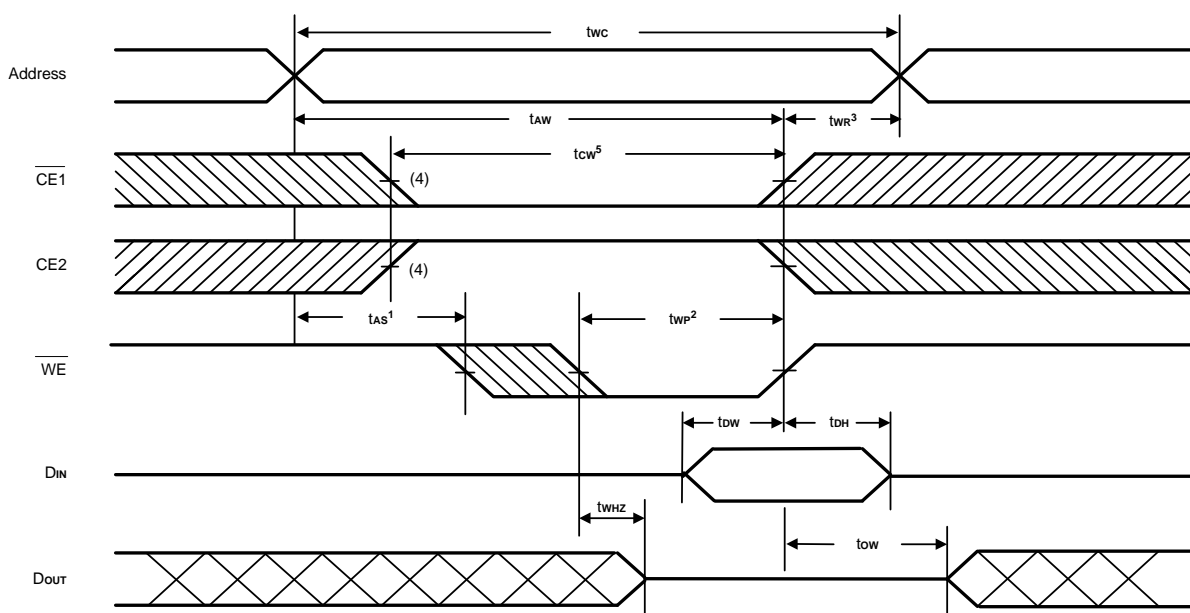
**Timing Waveforms (continued)**
**Read Cycle 4 <sup>(1)</sup>**

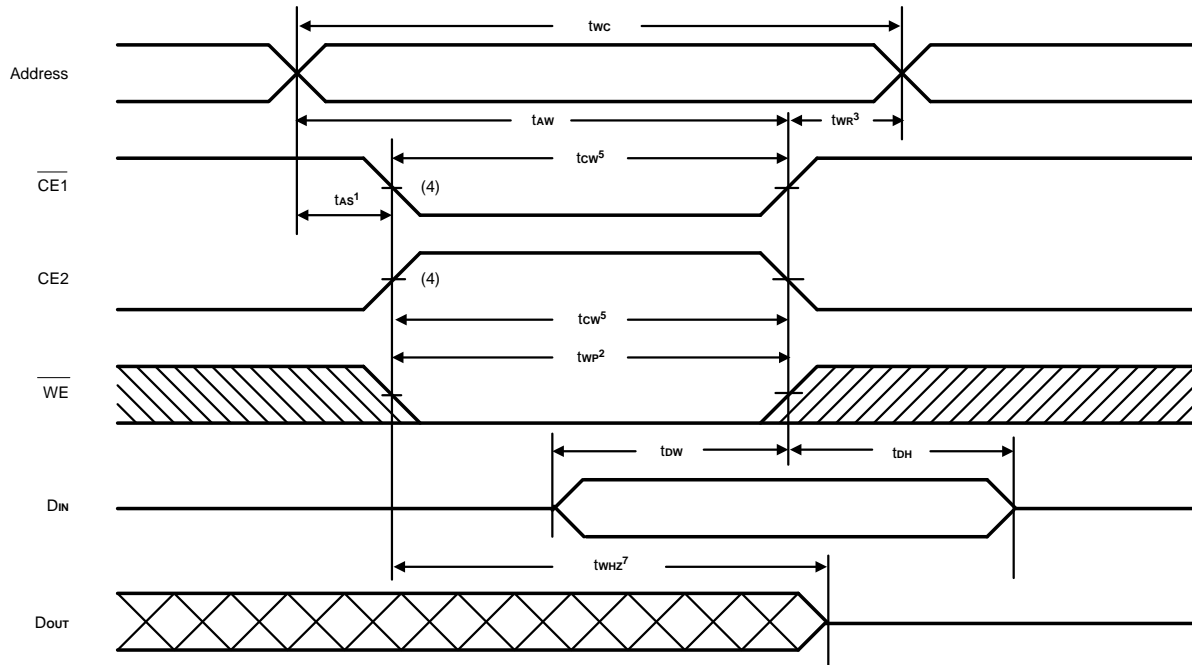
- Notes:
1.  $\overline{WE}$  is high for Read Cycle.
  2. Device is continuously enabled  $\overline{CE1} = V_{IL}$  and  $CE2 = V_{IH}$ .
  3. Address valid prior to or coincident with  $\overline{CE1}$  transition low.
  4.  $\overline{OE} = V_{IL}$ .
  5. Transition is measured  $\pm 500\text{mV}$  from steady state. This parameter is sampled and not 100% tested.
  6.  $\overline{CE2}$  is high.
  7.  $\overline{CE1}$  is low.
  8. Address valid prior to or coincident with  $CE2$  transition high.

**Write Cycle 1 <sup>(6)</sup>**
**(Write Enable Controlled)**

**Timing Waveforms (continued)**
**Write Cycle 2  
(Chip Enable Controlled)**

- Notes:
1.  $t_{as}$  is measured from the address valid to the beginning of Write.
  2. A Write occurs during the overlap ( $t_{wp}$ ) of a low  $\overline{CE1}$ , a high CE2 and a low  $\overline{WE}$ .
  3.  $t_{wr}$  is measured from the earliest of  $\overline{CE1}$  or  $\overline{WE}$  going high or CE2 going low to the end of the Write cycle.
  4. If the  $\overline{CE1}$  low transition or the CE2 high transition occurs simultaneously with the  $\overline{WE}$  low transition or after the  $\overline{WE}$  transition, outputs remain in a high impedance state.
  5.  $t_{cw}$  is measured from the later of  $\overline{CE1}$  going low or CE2 going high to the end of Write.
  6.  $\overline{OE}$  is continuously low. ( $\overline{OE} = V_{IL}$ )
  7. Transition is measured  $\pm 500\text{mV}$  from steady state. This parameter is sampled and not 100% tested.

**AC Test Conditions**

|  |                     |
|--|---------------------|
| Input Pulse Levels                       | 0.4V to 2.4V        |
| Input Rise and Fall Time                 | 5 ns                |
| Input and Output Timing Reference Levels | 1.5V                |
| Output Load                              | See Figures 1 and 2 |

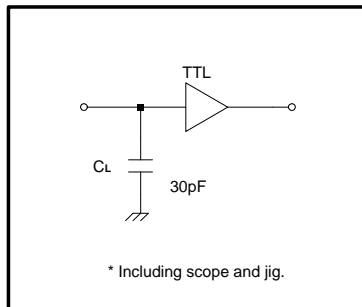
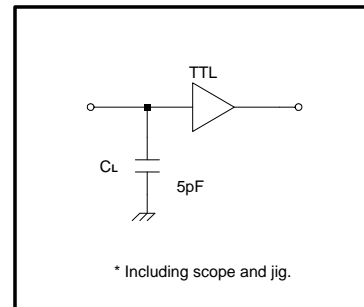
**Figure 1. Output Load**

**Figure 2. Output Load for  $t_{CL1}$ ,  $t_{CL2}$ ,  $t_{OHZ}$ ,  $t_{OLZ}$ ,  $t_{CHZ1}$ ,  $t_{CHZ2}$ ,  $t_{WHZ}$ , and  $t_{OW}$** 
**Data Retention Characteristics** ( $T_A = -40^\circ\text{C}$  to  $85^\circ\text{C}$ )

| Symbol      | Parameter                           | Min. | Max. | Unit          | Conditions   |
|-------------|-------------------------------------|------|------|---------------|--|
| $V_{DR1}$   | VCC for Data Retention              | 1.5  | 3.6  | V             | $\overline{CE1} \geq V_{CC} - 0.2V$  |
| $V_{DR2}$   |                                     | 1.5  | 3.6  | V             | $CE2 \leq 0.2V$ ,  |
| $I_{CCDR1}$ | Data Retention Current              | -    | 1*   | $\mu\text{A}$ | $V_{CC} = 1.5V$ ,<br>$\overline{CE1} \geq V_{CC} - 0.2V$ ,<br>$V_{IN} \geq 0V$ |
| $I_{CCDR2}$ |                                     | -    | 1*   | $\mu\text{A}$ | $V_{CC} = 1.5V$ ,<br>$CE2 \leq 0.2V$ ,<br>$V_{IN} \geq 0V$                     |
| $t_{CDR}$   | Chip Disable to Data Retention Time | 0    | -    | ns            | See Retention Waveform   |
| $t_R$       | Operation Recovery Time             | 5    | -    | ms            |  |

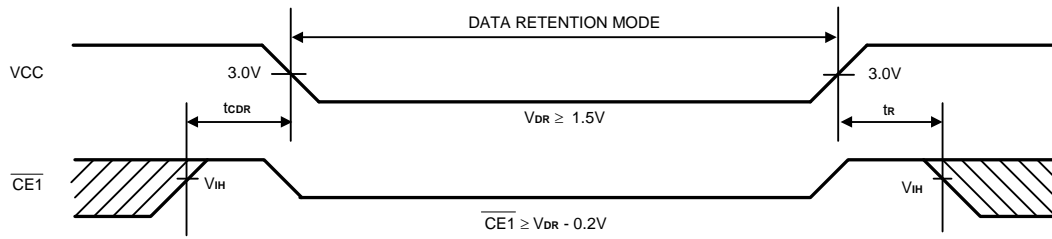
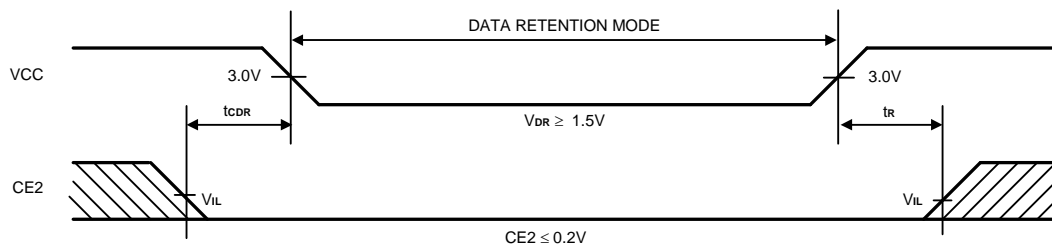
\* LP62S1024B-45LLI/55LLI/70LLI  $I_{CCDR}$ : max.  $1\mu\text{A}$  at  $T_A = 0^\circ\text{C}$  to  $+40^\circ\text{C}$

**Low VCC Data Retention Waveform (1) ( $\overline{\text{CE1}}$  Controlled)**

**Low VCC Data Retention Waveform (2) (CE2 Controlled)**

**Ordering Information**

| Part No.           | Access Time (ns) | Operating Current Max. (mA) | Standby Current Max. ( $\mu$ A) | Package           |
|--------------------|------------------|-----------------------------|---------------------------------|-------------------|
| LP62S1024BM-45LLIF | 45               | 30                          | 5                               | 32L Pb-Free SOP   |
| LP62S1024BV-45LLIF |                  |                             |                                 | 32L Pb-Free TSOP  |
| LP62S1024BX-45LLIF |                  |                             |                                 | 32L Pb-Free TSSOP |
| LP62S1024BU-45LLIF |                  |                             |                                 | 36L Pb-Free CSP   |
| LP62S1024BM-55LLI  | 55               | 30                          | 5                               | 32L SOP           |
| LP62S1024BM-55LLIF |                  |                             |                                 | 32L Pb-Free SOP   |
| LP62S1024BV-55LLI  |                  |                             |                                 | 32L TSOP          |
| LP62S1024BV-55LLIF |                  |                             |                                 | 32L Pb-Free TSOP  |
| LP62S1024BX-55LLI  |                  |                             |                                 | 32L TSSOP         |
| LP62S1024BX-55LLIF |                  |                             |                                 | 32L Pb-Free TSSOP |
| LP62S1024BU-55LLI  |                  |                             |                                 | 36L CSP           |
| LP62S1024BU-55LLIF |                  |                             |                                 | 36L Pb-Free CSP   |
| LP62S1024BM-70LLI  | 70               | 30                          | 5                               | 32L SOP           |
| LP62S1024BM-70LLIF |                  |                             |                                 | 32L Pb-Free SOP   |
| LP62S1024BV-70LLI  |                  |                             |                                 | 32L TSOP          |
| LP62S1024BV-70LLIF |                  |                             |                                 | 32L Pb-Free TSOP  |
| LP62S1024BX-70LLI  |                  |                             |                                 | 32L TSSOP         |
| LP62S1024BX-70LLIF |                  |                             |                                 | 32L Pb-Free TSSOP |
| LP62S1024BU-70LLI  |                  |                             |                                 | 36L CSP           |
| LP62S1024BU-70LLIF |                  |                             |                                 | 36L Pb-Free CSP   |

**Package Information**
**SOP (W.B.) 32L Outline Dimensions**

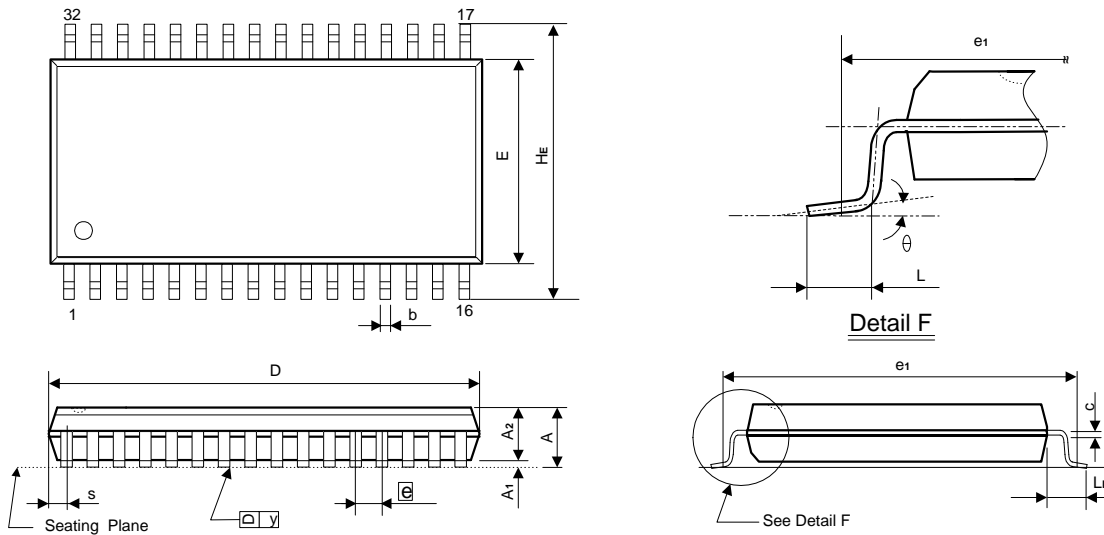
unit: inches/mm



| Symbol         | Dimensions in inches    | Dimensions in mm        |
|----------------|-------------------------|-------------------------|
| A              | 0.118 Max.              | 3.00 Max.               |
| A1             | 0.004 Min.              | 0.10 Min.               |
| A2             | 0.106±0.005             | 2.69±0.13               |
| b              | 0.016 +0.004<br>-0.002  | 0.41 +0.10<br>-0.05     |
| c              | 0.008 +0.004<br>-0.002  | 0.20 +0.10<br>-0.05     |
| D              | 0.805 Typ. (0.820 Max.) | 20.45 Typ. (20.83 Max.) |
| E              | 0.445±0.010             | 11.30±0.25              |
| e              | 0.050 ±0.006            | 1.27±0.15               |
| e <sub>1</sub> | 0.525 NOM.              | 13.34 NOM.              |
| HE             | 0.556±0.010             | 14.12±0.25              |
| L              | 0.031±0.008             | 0.79±0.20               |
| LE             | 0.055±0.008             | 1.40±0.20               |
| S              | 0.044 Max.              | 1.12 Max.               |
| y              | 0.004 Max.              | 0.10 Max.               |
| θ              | 0° ~ 10°                | 0° ~ 10°                |

**Notes:**

1. The maximum value of dimension D includes end flash.
2. Dimension E does not include resin fins.
3. Dimension e<sub>1</sub> is for PC Board surface mount pad pitch design reference only.
4. Dimension S includes end flash.

**Package Information**
**TSOP 32L TYPE I (8 X 20mm) Outline Dimensions**

unit: inches/mm

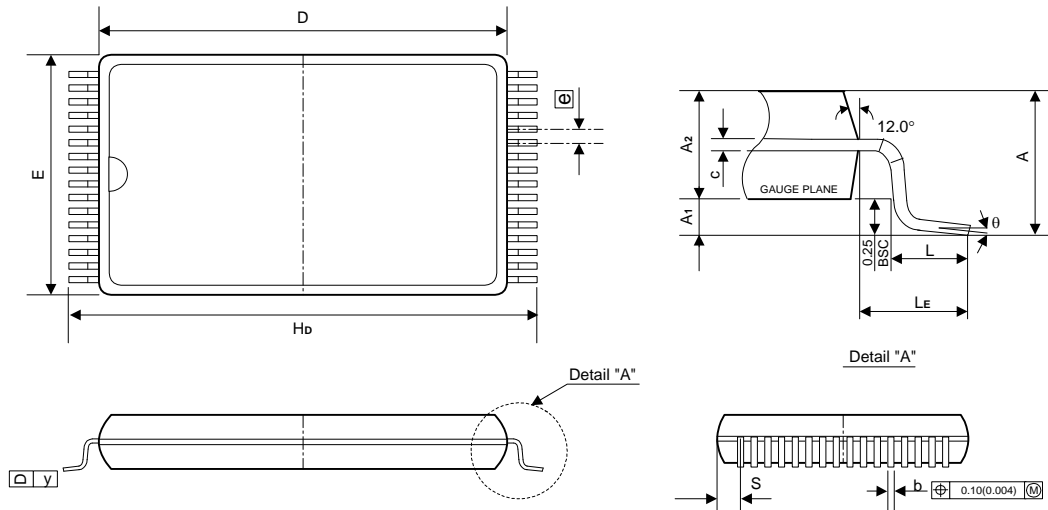

| Symbol         | Dimensions in inches | Dimensions in mm |
|----------------|----------------------|------------------|
| A              | 0.047 Max.           | 1.20 Max.        |
| A1             | 0.004±0.002          | 0.10±0.05        |
| A2             | 0.039±0.002          | 1.00±0.05        |
| b              | 0.008±0.001          | 0.20±0.03        |
| c              | 0.006±0.001          | 0.15±0.02        |
| D              | 0.724±0.004          | 18.40±0.10       |
| E              | 0.315±0.004          | 8.00±0.10        |
| e <sub>1</sub> | 0.020 TYP.           | 0.50 TYP.        |
| Hb             | 0.787±0.007          | 20.00±0.20       |
| L              | 0.020±0.004          | 0.50±0.10        |
| LE             | 0.031 TYP.           | 0.80 TYP.        |
| S              | 0.0167 TYP.          | 0.425 TYP.       |
| Y              | 0.004 Max.           | 0.10 Max.        |
| θ              | 0° ~ 6°              | 0° ~ 6°          |

**Notes:**

1. The maximum value of dimension D includes end flash.
2. Dimension E does not include resin fins.
3. Dimension e<sub>1</sub> is for PC Board surface mount pad pitch design reference only.
4. Dimension S includes end flash.

**Package Information**
**TSSOP 32L TYPE I (8 X 13.4mm) Outline Dimensions**

unit: inches/mm

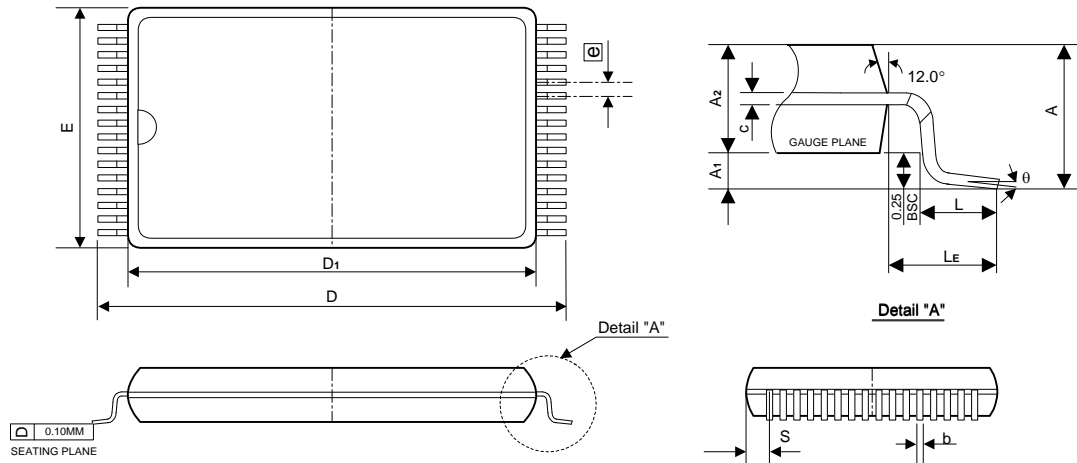

| Symbol | Dimensions in inches | Dimensions in mm |
|--------|----------------------|------------------|
| A      | 0.049 Max.           | 1.25 Max.        |
| A1     | 0.002 Min.           | 0.05 Min.        |
| A2     | 0.039±0.002          | 1.00±0.05        |
| b      | 0.008±0.001          | 0.20±0.03        |
| c      | 0.006±0.0003         | 0.15±0.008       |
| E      | 0.315±0.004          | 8.00±0.10        |
| e      | 0.020 TYP.           | 0.50 TYP.        |
| D      | 0.528±0.008          | 13.40±0.20       |
| D1     | 0.465±0.004          | 11.80±0.10       |
| L      | 0.02±0.008           | 0.50±0.20        |
| LE     | 0.0266 Min.          | 0.675 Min.       |
| S      | 0.0109 TYP.          | 0.278 TYP.       |
| y      | 0.004 Max.           | 0.10 Max.        |
| θ      | 0° ~ 6°              | 0° ~ 6°          |

**Notes:**

1. The maximum value of dimension D includes end flash.
2. Dimension E does not include resin fins.
3. Dimension e<sub>1</sub> is for PC Board surface mount pad pitch design reference only.
4. Dimension S includes end flash.

**Package Information**
**36LD CSP (6 x 8 mm) Outline Dimensions**

unit: mm

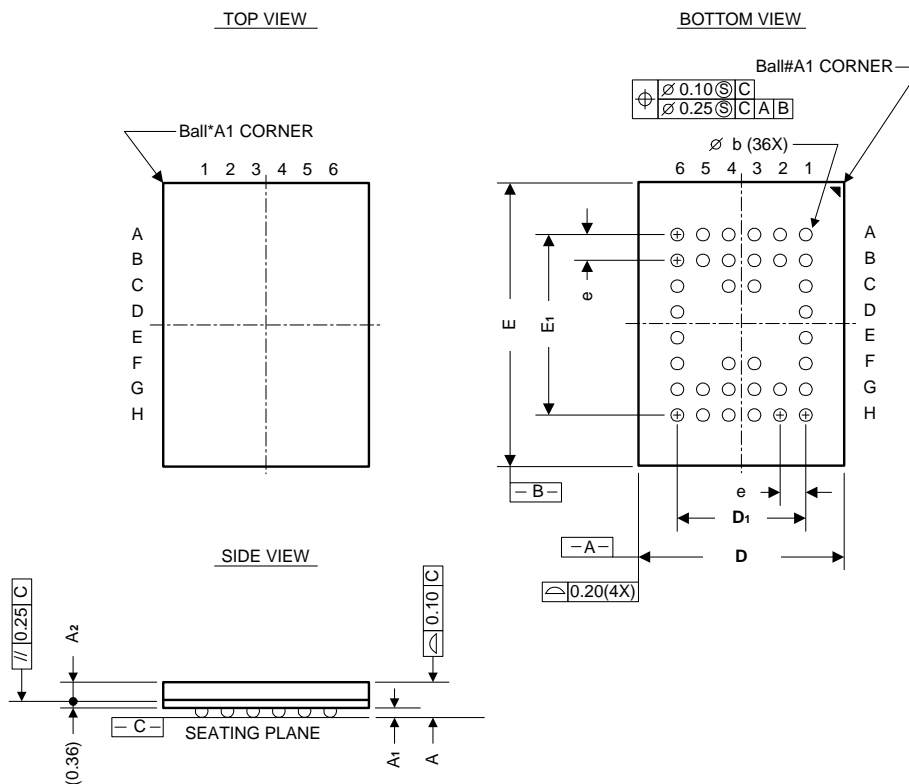

| Symbol         | Dimensions in mm |      |      |
|----------------|------------------|------|------|
|                | MIN.             | NOM. | MAX. |
| A              | 1.00             | 1.10 | 1.20 |
| A <sub>1</sub> | 0.16             | 0.21 | 0.26 |
| A <sub>2</sub> | 0.48             | 0.53 | 0.58 |
| D              | 5.80             | 6.00 | 6.20 |
| E              | 7.80             | 8.00 | 8.20 |
| D <sub>1</sub> | ---              | 3.75 | ---  |
| E <sub>1</sub> | ---              | 5.25 | ---  |
| e              | ---              | 0.75 | ---  |
| b              | 0.25             | 0.30 | 0.35 |

**Note:**

1. THE BALL DIAMETER, BALL PITCH, STAND-OFF & PACKAGE THICKNESS ARE DIFFERENT FROM JEDEC SPEC MO192 (LOW PROFILE BGA FAMILY).
2. PRIMARY DATUM C AND SEATING PLANE ARE DEFINED BY THE SPHERICAL CROWNS OF THE SOLDER BALLS.
3. DIMENSION b IS MEASURED AT THE MAXIMUM.
4. THERE SHALL BE A MINIMUM CLEARANCE OF 0.25mm BETWEEN THE EDGE OF THE SOLDER BALL AND THE BODY EDGE.