



LP621024D-I Series

128K X 8 BIT CMOS SRAM

Document Title

128K X 8 BIT CMOS SRAM

Revision History

<u>Rev. No.</u>	<u>History</u>	<u>Issue Date</u>	<u>Remark</u>
0.0	Initial issue	August 9, 2002	Preliminary
1.0	Final version release	July 17, 2003	Final
1.1	Add Pb-Free package type	August 19, 2004	
1.2	Remove non-Pb-free package type	July 3, 2006	



LP621024D-I Series

128K X 8 BIT CMOS SRAM

Features

- Single +5V power supply
- Access times: 55/70 ns (max.)
- Current:
 - Very low power version: Operating: 70mA (max.)
 - Standby: 50µA (max.)
- Full static operation, no clock or refreshing required
- All inputs and outputs are directly TTL-compatible
- Common I/O using three-state output
- Output enable and two chip enable inputs for easy application
- Data retention voltage: 2V (min.)
- Available in 32-pin DIP, SOP TSOP and TSSOP (8 X 13.4mm) packages
- Pb-Free package only
- All Pb-free (Lead-free) products are RoHS compliant

General Description

The LP621024D-I is a low operating current 1,048,576-bit static random access memory organized as 131,072 words by 8 bits and operates on a single 5V power supply. Inputs and three-state outputs are TTL compatible and allow for direct interfacing with common system bus structures.

Two chip enable inputs are provided for POWER-DOWN and device enable and an output enable input is included for easy interfacing.

Data retention is guaranteed at a power supply voltage as low as 2V.

Product Family

Product Family	Operating Temperature	VCC Range	Speed	Power Dissipation			Package Type
				Data Retention (I _{CCDR} , Typ.)	Standby (I _{SB1} , Typ.)	Operating (I _{CC2} , Typ.)	
LP621024D	-40°C ~ +85°C	4.5V~5.5V	55ns / 70ns	0.5µA	2µA	10mA	32L DIP/ SOP/TSOP/ TSSOP

1. Typical values are measured at VCC = 5.0V, T_A = 25°C and not 100% tested.
2. Data retention current VCC = 2.0V.

Pin Configurations

■ DIP

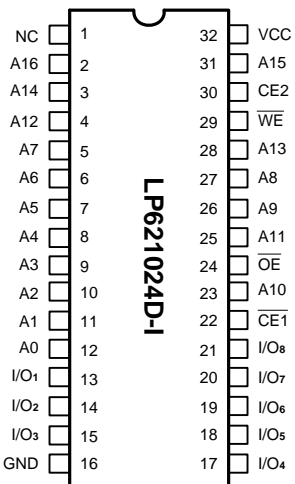

■ SOP

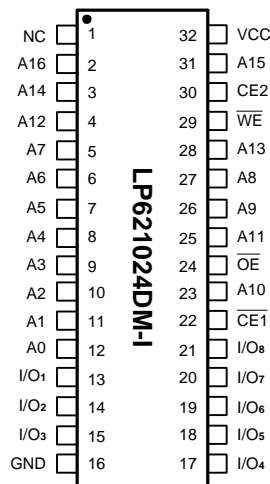

■ TSOP/(TSSOP)

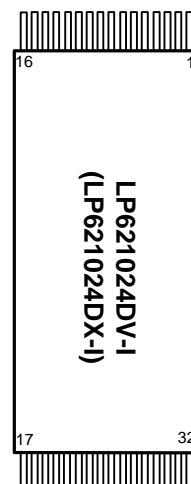

Pin No.	1	2	3	4	5	6	7	8	9	10	11	12	13	14	15	16
Pin Name	A11	A9	A8	A13	WE	CE2	A15	VCC	NC	A16	A14	A12	A7	A6	A5	A4
Pin No.	17	18	19	20	21	22	23	24	25	26	27	28	29	30	31	32
Pin Name	A3	A2	A1	A0	I/O1	I/O2	I/O3	GND	I/O4	I/O5	I/O6	I/O7	I/O8	CE1	A10	OE

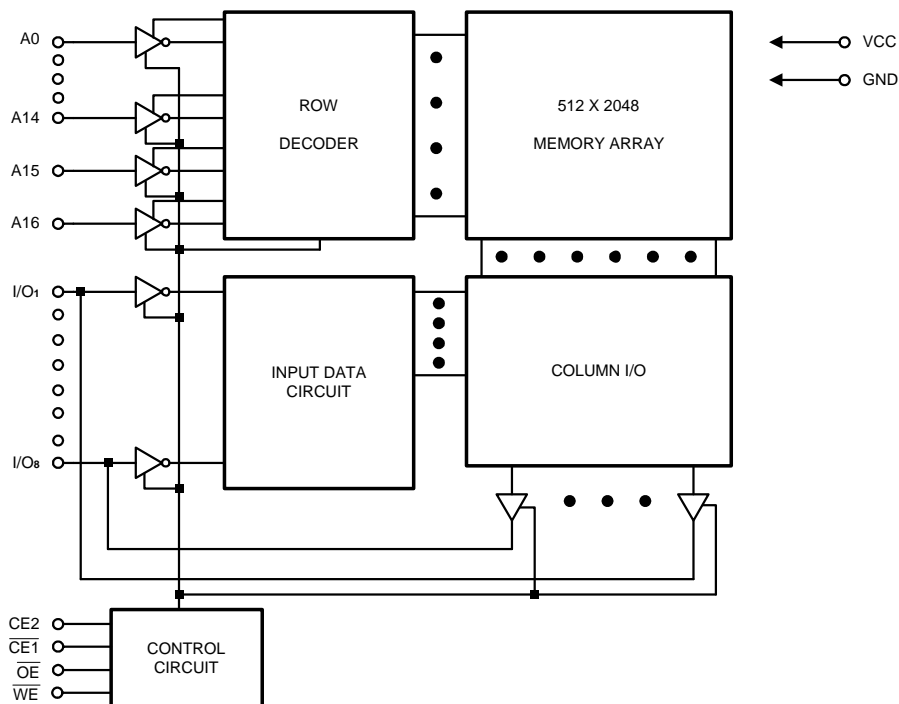
Block Diagram

Pin Descriptions - DIP/SOP

Pin No.	Symbol	Description
1	NC	No Connection
2 - 12, 23, 25 - 28, 31	A0 - A16	Address Inputs
13 - 15, 17 - 21	I/O ₁ - I/O ₈	Data Input/Outputs
16	GND	Ground
22	$\overline{CE1}$	Chip Enable
24	\overline{OE}	Output Enable
29	\overline{WE}	Write Enable
30	CE2	Chip Enable
32	VCC	Power Supply (+5V)

Pin Description - TSOP/TSSOP

Pin No.	Symbol	Description
1 - 4, 7, 10 - 20, 31	A0 - A16	Address Inputs
5	\overline{WE}	Write Enable
6	CE2	Chip Enable
8	VCC	Power Supply
9	NC	No Connection
21 - 23, 25 - 29	I/O ₁ - I/O ₈	Data Input/Outputs
24	GND	Ground
30	$\overline{CE1}$	Chip Enable
32	\overline{OE}	Output Enable

Recommended DC Operating Conditions

 (T_A = -40°C to + 85°C)

Symbol	Parameter	Min.	Typ.	Max.	Unit
	Supply Voltage	4.5	5.0	5.5	V
GND	Ground	0	0	0	V
V _{IH}	Input High Voltage	2.2	3.5	VCC + 0.3	V
V _{IL}	Input Low Voltage	-0.3	0	+0.8	V
C _L	Output Load	-	-	30	pF
TTL	Output Load	-	-	1	-

Absolute Maximum Ratings*

VCC to GND-0.5V to + 7.0V
 IN, IN/OUT Volt to GND -0.5V to VCC + 0.5V
 Operating Temperature, Topr -40°C to + 85°C
 Storage Temperature, Tstg -55°C to + 125°C
 Temperature Under Bias, Tbias -40°C to + 85°C
 Power Dissipation, Pr 0.7W
 Soldering Temp. & Time 260°C, 10 sec

***Comments**

Stresses above those listed under "Absolute Maximum Ratings" may cause permanent damage to this device. These are stress ratings only. Functional operation of this device at these or any other conditions above those indicated in the operational sections of this specification is not implied or intended. Exposure to the absolute maximum rating conditions for extended periods may affect device reliability.

DC Electrical Characteristics (T_A = -40°C to + 85°C, VCC = 5V ± 10%, GND = 0V)

Symbol	Parameter	LP621024D-55LLI		LP621024D-70LLI		Unit	Conditions
		Min.	Max.	Min.	Max.		
I _{LI}	Input Leakage Current	-	1	-	1	μA	V _{IN} = GND to VCC
I _{LO}	Output Leakage Current	-	1	-	1	μA	$\overline{CE1} = V_{IH}$ or $CE2 = V_{IL}$ or $\overline{OE} = V_{IH}$ or $\overline{WE} = V_{IL}$ V _{IO} = GND to VCC
I _{CC}	Active Power Supply Current	-	15	-	15	mA	$\overline{CE1} = V_{IL}$, CE2 = V _{IH} I _{VO} = 0mA
I _{CC1}	Dynamic Operating Current	-	70	-	70	mA	Min. Cycle, Duty = 100% $\overline{CE1} = V_{IL}$, CE2 = V _{IH} I _{VO} = 0mA
I _{CC2}		-	15	-	15	mA	$\overline{CE1} = V_{IL}$, CE2 = V _{IH} V _{IH} = VCC, V _{IL} = 0V f = 1MHz, I _{VO} = 0mA

DC Electrical Characteristics (continued)

Symbol	Parameter	LP621024D-55LLI		LP621024D-70LLI		Unit	Conditions
		Min.	Max.	Min.	Max.		
I _{SB}	Standby Power Supply Current	-	2	-	2	mA	$\overline{CE1} = V_{IH}$ or $CE2 = V_{IL}$
I _{SB1}		-	50	-	50	μA	$\overline{CE1} \geq V_{CC} - 0.2V$ $CE2 \geq V_{CC} - 0.2V$ $V_{IN} \geq 0V$
I _{SB2}		-	50	-	50	μA	$CE2 \leq 0.2V$ $V_{IN} \geq 0V$
V _{OL}	Output Low Voltage	-	0.4	-	0.4	V	I _{OL} = 2.1mA
V _{OH}	Output High Voltage	2.4	-	2.4	-	V	I _{OH} = -1.0mA

Truth Table

Mode	$\overline{CE1}$	CE2	\overline{OE}	\overline{WE}	I/O Operation	Supply Current
Standby	H	X	X	X	High Z	I _{SB} , I _{SB1}
	X	L	X	X	High Z	I _{SB} , I _{SB2}
Output Disable	L	H	H	H	High Z	I _{CC} , I _{CC1} , I _{CC2}
Read	L	H	L	H	D _{OUT}	I _{CC} , I _{CC1} , I _{CC2}
Write	L	H	X	L	D _{IN}	I _{CC} , I _{CC1} , I _{CC2}

Note: X = H or L

Capacitance (T_A = 25°C, f = 1.0MHz)

Symbol	Parameter	Min.	Max.	Unit	Conditions
C _{IN} *	Input Capacitance		6	pF	V _{IN} = 0V
C _{I/O} *	Input/Output Capacitance		8	pF	V _{I/O} = 0V

* These parameters are sampled and not 100% tested.

AC Characteristics ($T_A = -40^{\circ}\text{C}$ to $+85^{\circ}\text{C}$, $V_{CC} = 5\text{V} \pm 10\%$)

Symbol	Parameter	LP621024D-55LLI		LP621024D-70LLI		Unit	
		Min.	Max.	Min.	Max.		
Read Cycle							
t _{RC}	Read Cycle Time	55	-	70	-	ns	
t _{AA}	Address Access Time	-	55	-	70	ns	
t _{ACE1}	Chip Enable Access Time	$\overline{\text{CE1}}$	-	55	-	70	ns
t _{ACE2}		CE2	-	55	-	70	ns
t _{OE}	Output Enable to Output Valid	-	30	-	35	ns	
t _{CLZ1}	Chip Enable to Output in Low Z	$\overline{\text{CE1}}$	10	-	10	-	ns
t _{CLZ2}		CE2	10	-	10	-	ns
t _{OLZ}	Output Enable to Output in Low Z	5	-	5	-	ns	
t _{CHZ1}	Chip Disable to Output in High Z	$\overline{\text{CE1}}$	0	20	0	25	ns
t _{CHZ2}		CE2	0	20	0	25	ns
t _{OHZ}	Output Disable to Output in High Z	0	20	0	25	ns	
t _{OH}	Output Hold from Address Change	5	-	5	-	ns	
Write Cycle							
t _{WC}	Write Cycle Time	55	-	70	-	ns	
t _{CW}	Chip Enable to End of Write	50	-	60	-	ns	
t _{AS}	Address Setup Time	0	-	0	-	ns	
t _{AW}	Address Valid to End of Write	50	-	60	-	ns	
t _{WP}	Write Pulse Width	40	-	50	-	ns	
t _{WR}	Write Recovery Time	0	-	0	-	ns	
t _{WHZ}	Write to Output in High Z	0	25	0	30	ns	
t _{DW}	Data to Write Time Overlap	25	-	30	-	ns	
t _{DH}	Data Hold from Write Time	0	-	0	-	ns	
t _{OW}	Output Active from End of Write	5	-	5	-	ns	

Notes: t_{CHZ1}, t_{CHZ2}, t_{OHZ}, and t_{WHZ} are defined as the time at which the outputs achieve the open circuit condition and are not referred to output voltage levels.

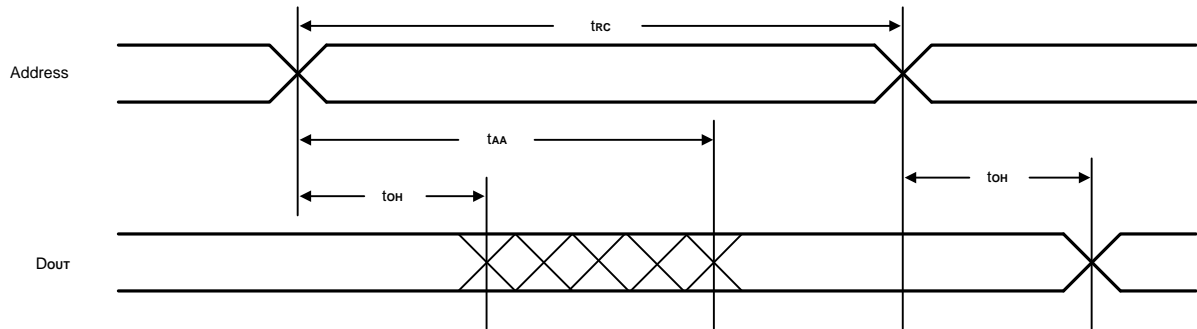
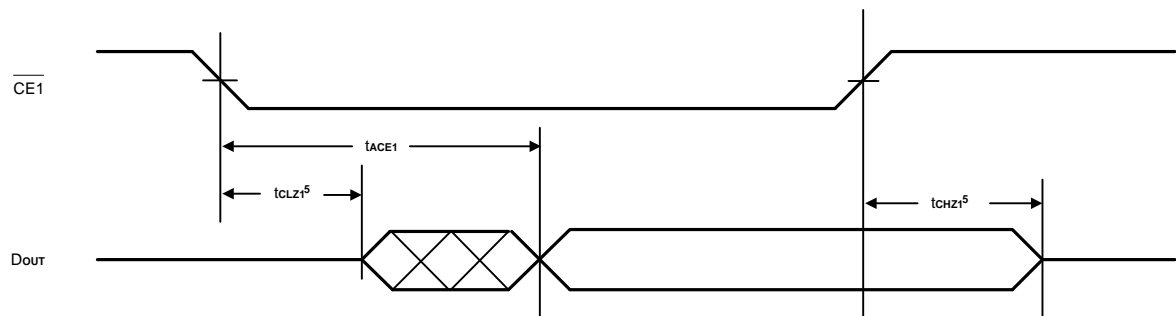
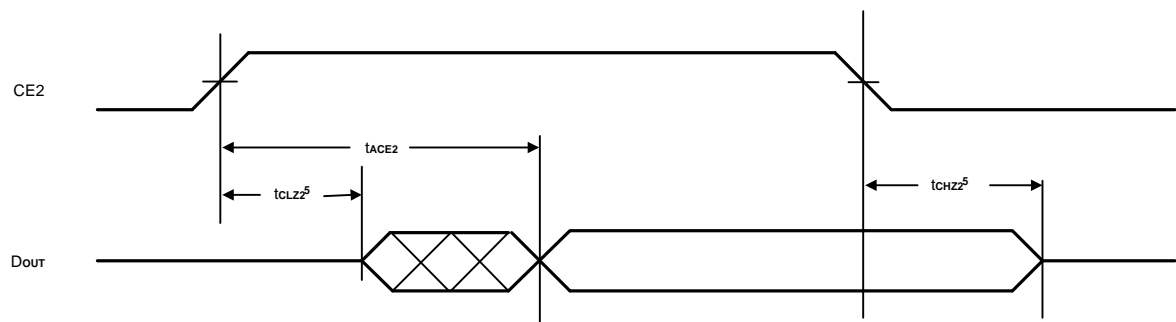
Timing Waveforms
Read Cycle 1^(1, 2, 4)

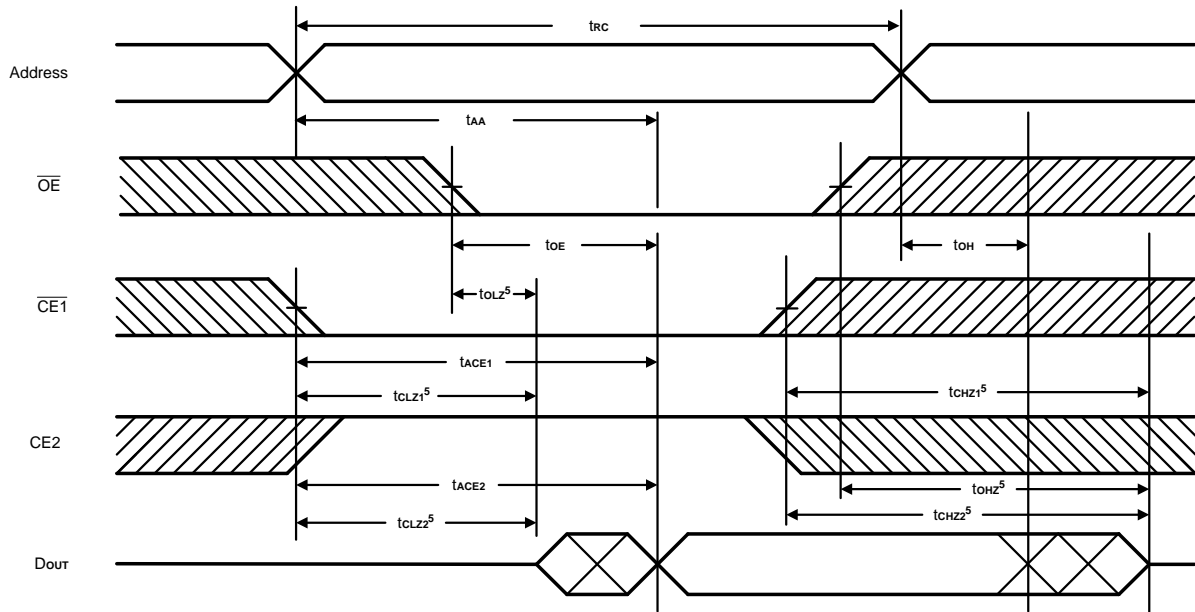
Read Cycle 2^(1, 3, 4, 6)

Read Cycle 3^(1, 4, 7, 8)

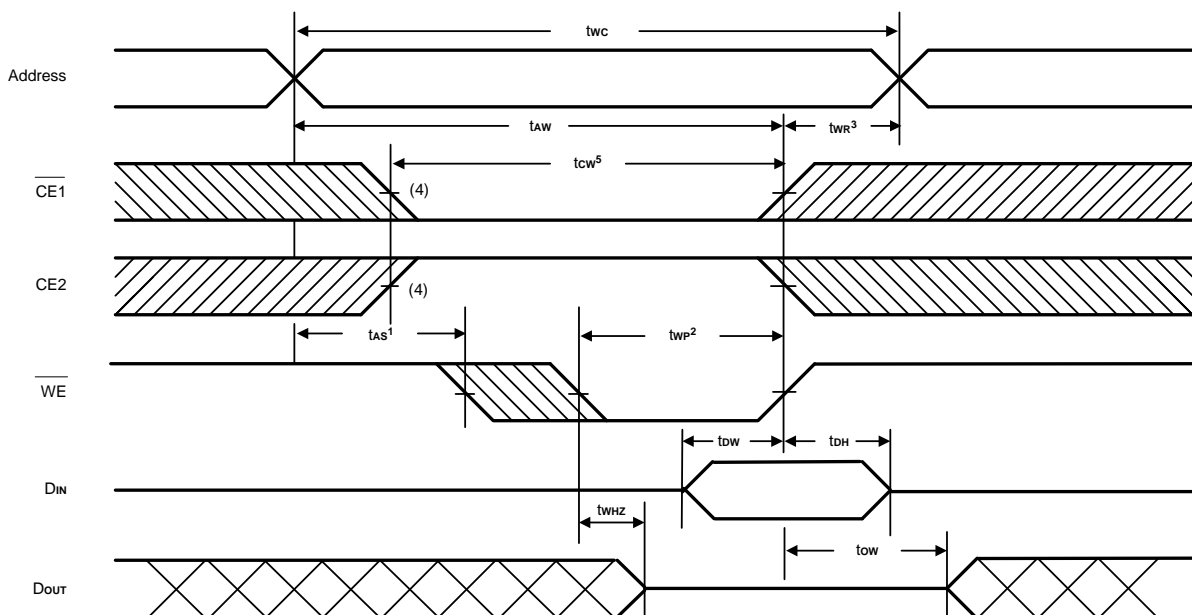
Timing Waveforms (continued)
Read Cycle 4⁽¹⁾

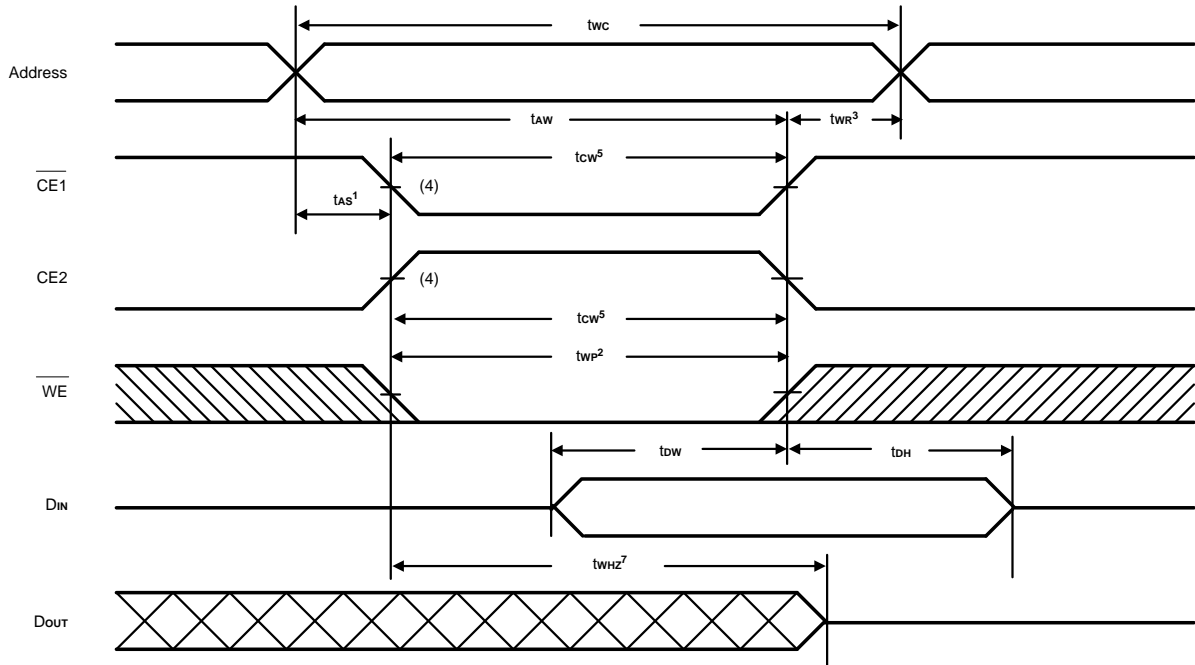
- Notes:
1. \overline{WE} is high for Read Cycle.
 2. Device is continuously enabled $\overline{CE1} = V_{IL}$ and $CE2 = V_{IH}$.
 3. Address valid prior to or coincident with $\overline{CE1}$ transition low.
 4. $\overline{OE} = V_{IL}$.
 5. Transition is measured $\pm 500\text{mV}$ from steady state. This parameter is sampled and not 100% tested.
 6. $\overline{CE2}$ is high.
 7. $\overline{CE1}$ is low.
 8. Address valid prior to or coincident with $CE2$ transition high.

Write Cycle 1⁽⁶⁾
(Write Enable Controlled)

Timing Waveforms (continued)
**Write Cycle 2
(Chip Enable Controlled)**

- Notes:
1. t_{AS} is measured from the address valid to the beginning of Write.
 2. A Write occurs during the overlap (t_{wp}) of a low $\overline{CE1}$, a high CE2 and a low \overline{WE} .
 3. t_{WR} is measured from the earliest of $\overline{CE1}$ or \overline{WE} going high or CE2 going low to the end of the Write cycle.
 4. If the $\overline{CE1}$ low transition or the CE2 high transition occurs simultaneously with the \overline{WE} low transition or after the \overline{WE} transition, outputs remain in a high impedance state.
 5. t_{cw} is measured from the later of $\overline{CE1}$ going low or CE2 going high to the end of Write.
 6. \overline{OE} is continuously low. ($\overline{OE} = V_{IL}$)
 7. Transition is measured $\pm 500\text{mV}$ from steady state. This parameter is sampled and not 100% tested.

AC Test Conditions

Input Pulse Levels	0V to 3.0V
Input Rise and Fall Time	5 ns
Input and Output Timing Reference Levels	1.5V
Output Load	See Figures 1 and 2

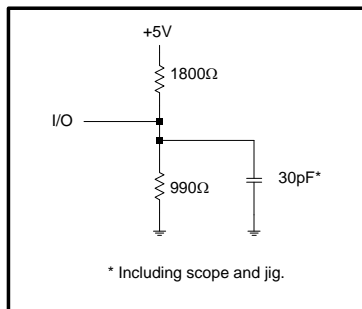
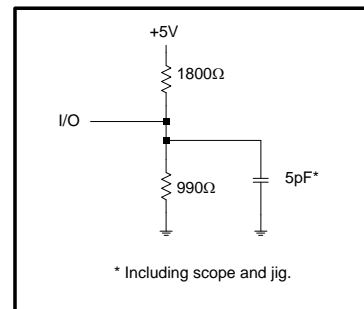
Figure 1. Output Load

Figure 2. Output Load for t_{CLZ1} , t_{CLZ2} , t_{OHZ} , t_{OLZ} , t_{CHZ1} , t_{CHZ2} , t_{WHZ} , and t_{OW}
Data Retention Characteristics ($T_A = -40^\circ\text{C}$ to 85°C)

Symbol	Parameter	Min.	Max.	Unit	Conditions
V_{DR1}	VCC for Data Retention	2.0	5.5	V	$\overline{CE1} \geq V_{CC} - 0.2V$
V_{DR2}		2.0	5.5	V	$CE2 \leq 0.2V$ $\overline{CE1} \geq V_{CC} - 0.2V$ or $\overline{CE1} \leq 0.2V$
I_{CCDR1}	Data Retention Current	-	20**	μA	$V_{CC} = 2.0V$, $\overline{CE1} \geq V_{CC} - 0.2V$ $CE2 \geq V_{CC} - 0.2V$ $V_{IN} \geq 0V$
I_{CCDR2}					$V_{CC} = 2.0V$ $CE2 \leq 0.2V$ $V_{IN} \geq 0V$
t_{CDR}	Chip Disable to Data Retention Time	0	-	ns	See Retention Waveform
t_R	Operation Recovery Time	5	-	ms	

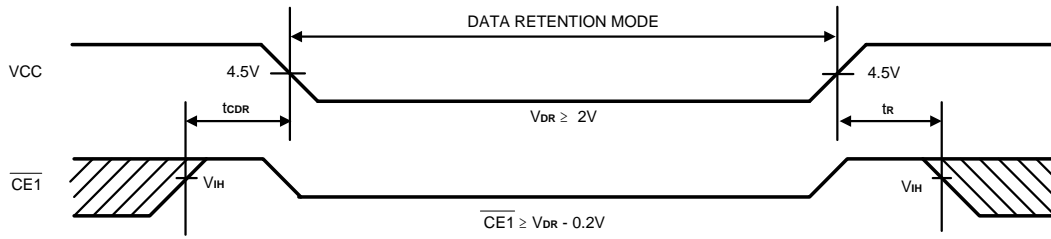
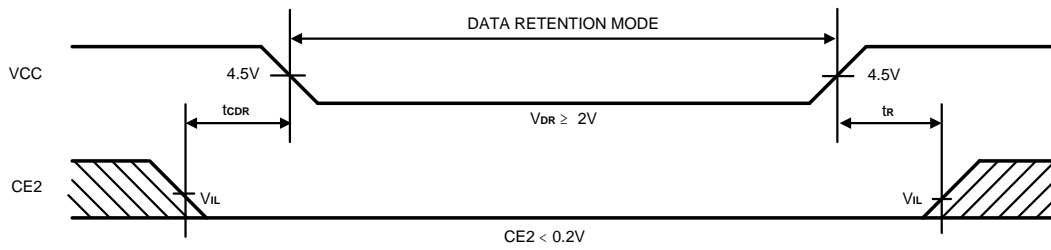
** LP621024D-55LLI/70LLI I_{CCDR} : Max. $2\mu\text{A}$ at $T_A = 0^\circ\text{C}$ to $+40^\circ\text{C}$

Low VCC Data Retention Waveform (1) ($\overline{\text{CE1}}$ Controlled)

Low VCC Data Retention Waveform (2) (CE2 Controlled)

Ordering Information

Part No.	Access Time (ns)	Operating Current Max. (mA)	Standby Current Max. (μ A)	Package
LP621024D-55LLIF	55	70	50	32L Pb-Free DIP
LP621024DM-55LLIF		70	50	32L Pb-Free SOP
LP621024DV-55LLIF		70	50	32L Pb-Free TSOP
LP621024DX-55LLIF		70	50	32L Pb-Free TSSOP
LP621024D-70LLIF	70	70	50	32L Pb-Free DIP
LP621024DM-70LLIF		70	50	32L Pb-Free SOP
LP621024DV-70LLIF		70	50	32L Pb-Free TSOP
LP621024DX-70LLIF		70	50	32L Pb-Free TSSOP

Package Information
P-DIP 32L Outline Dimensions

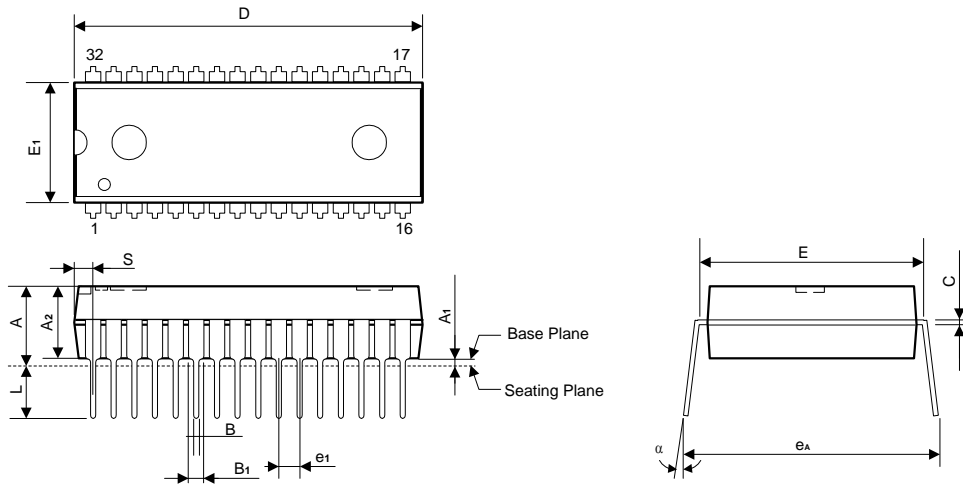
unit: inches/mm



Symbol	Dimensions in inches	Dimensions in mm
A	0.210 Max.	5.33 Max.
A1	0.010 Min.	0.25 Min.
A2	0.155±0.010	3.94±0.25
B	0.018 +0.004 -0.002	0.46 +0.10 -0.05
B1	0.050 +0.004 -0.002	1.27 +0.10 -0.05
C	0.010 +0.004 -0.002	0.25 +0.11 -0.05
D	1.650 Typ. (1.670 Max.)	41.91 Typ. (42.42 Max.)
E	0.600±0.010	15.24±0.25
E1	0.550 Typ. (0.562 Max.)	13.97 Typ. (14.27 Max.)
e1	0.100±0.010	2.54±0.25
L	0.130±0.010	3.30±0.25
α	0° ~ 15°	0° ~ 15°
eA	0.655±0.035	16.64±0.89
S	0.090 Max.	2.29 Max.

Notes:

1. The maximum value of dimension D includes end flash.
2. Dimension E1 does not include resin fins.
3. Dimension S includes end flash.

Package Information
SOP (W.B.) 32L Outline Dimensions

unit: inches/mm

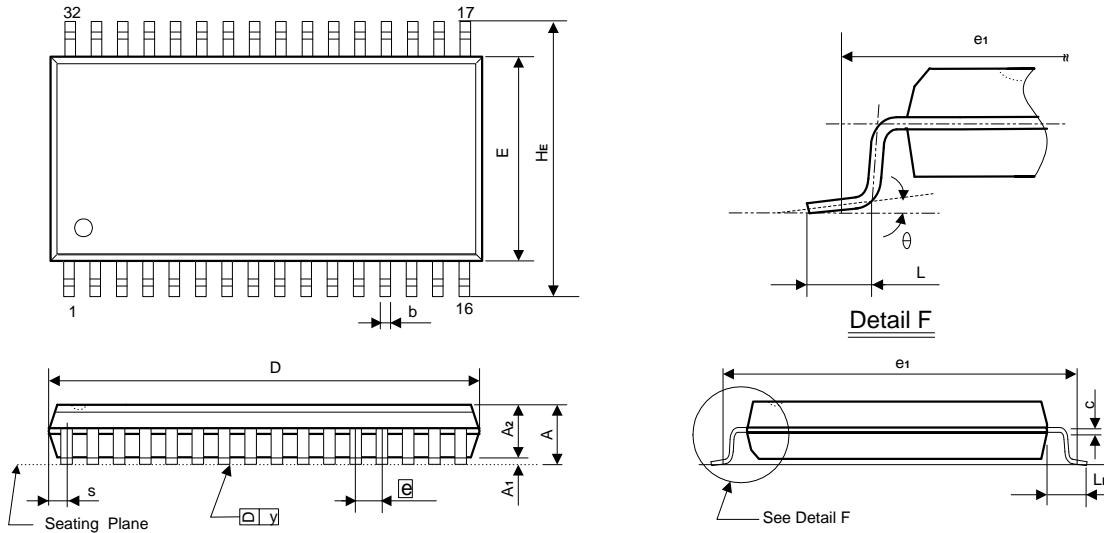

Symbol	Dimensions in inches	Dimensions in mm
A	0.118 Max.	3.00 Max.
A1	0.004 Min.	0.10 Min.
A2	0.106±0.005	2.69±0.13
b	0.016 +0.004 -0.002	0.41 +0.10 -0.05
c	0.008 +0.004 -0.002	0.20 +0.10 -0.05
D	0.805 Typ. (0.820 Max.)	20.45 Typ. (20.83 Max.)
E	0.445±0.010	11.30±0.25
e	0.050 ±0.006	1.27±0.15
e ₁	0.525 NOM.	13.34 NOM.
HE	0.556±0.010	14.12±0.25
L	0.031±0.008	0.79±0.20
LE	0.055±0.008	1.40±0.20
S	0.044 Max.	1.12 Max.
y	0.004 Max.	0.10 Max.
θ	0° ~ 10°	0° ~ 10°

Notes:

1. The maximum value of dimension D includes end flash.
2. Dimension E does not include resin fins.
3. Dimension e₁ is for PC Board surface mount pad pitch design reference only.
4. Dimension S includes end flash.

Package Information
TSOP 32L TYPE I (8 X 20mm) Outline Dimensions

unit: inches/mm

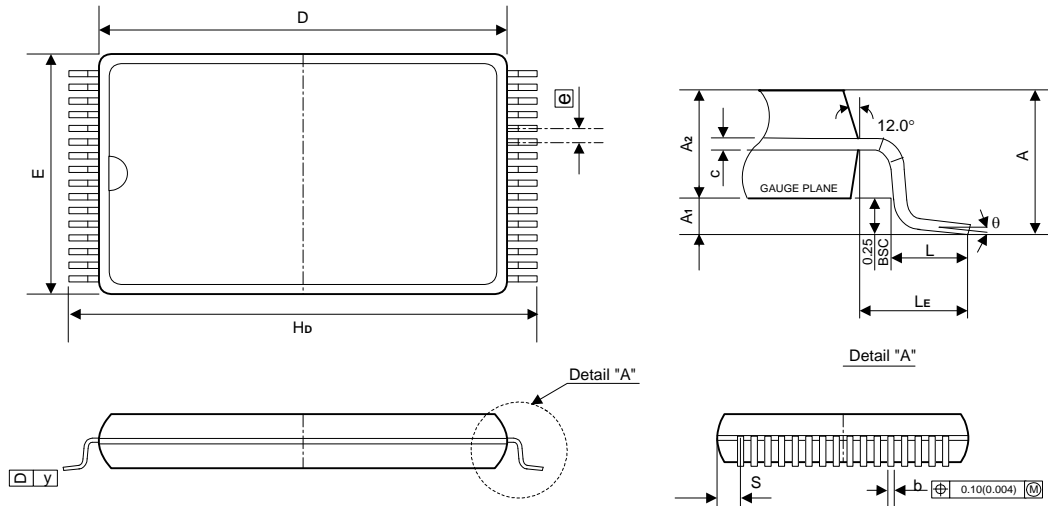

Symbol	Dimensions in inches	Dimensions in mm
A	0.047 Max.	1.20 Max.
A1	0.004±0.002	0.10±0.05
A2	0.039±0.002	1.00±0.05
b	0.008±0.001	0.20±0.03
c	0.006±0.001	0.15±0.02
D	0.724±0.004	18.40±0.10
E	0.315±0.004	8.00±0.10
e ₁	0.020 TYP.	0.50 TYP.
Hb	0.787±0.007	20.00±0.20
L	0.020±0.004	0.50±0.10
LE	0.031 TYP.	0.80 TYP.
S	0.0167 TYP.	0.425 TYP.
Y	0.004 Max.	0.10 Max.
θ	0° ~ 6°	0° ~ 6°

Notes:

1. The maximum value of dimension D includes end flash.
2. Dimension E does not include resin fins.
3. Dimension e₁ is for PC Board surface mount pad pitch design reference only.
4. Dimension S includes end flash.

Package Information
TSSOP 32L TYPE I (8 X 13.4mm) Outline Dimensions

unit: inches/mm

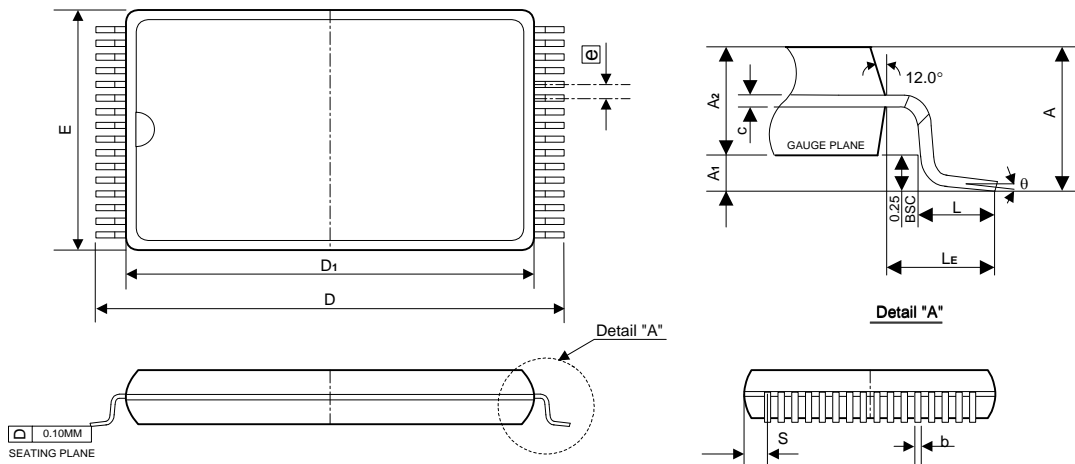

Symbol	Dimensions in inches	Dimensions in mm
A	0.049 Max.	1.25 Max.
A1	0.002 Min.	0.05 Min.
A2	0.039±0.002	1.00±0.05
b	0.008±0.001	0.20±0.03
c	0.006±0.0003	0.15±0.008
E	0.315±0.004	8.00±0.10
e	0.020 TYP.	0.50 TYP.
D	0.528±0.008	13.40±0.20
D1	0.465±0.004	11.80±0.10
L	0.02±0.008	0.50±0.20
LE	0.0266 Min.	0.675 Min.
S	0.0109 TYP.	0.278 TYP.
y	0.004 Max.	0.10 Max.
θ	0° ~ 6°	0° ~ 6°

Notes:

1. The maximum value of dimension D includes end flash.
2. Dimension E does not include resin fins.
3. Dimension e₁ is for PC Board surface mount pad pitch design reference only.
4. Dimension S includes end flash.