

AZP51

Low Phase Noise Sine Wave / CMOS to LVPECL Buffer / Translator

www.azmicrotek.com

DESCRIPTION

The AZP51 is a sine wave/CMOS to LVPECL buffer/translator optimized for very low phase noise (-165dBc/Hz). It is particularly useful in converting crystal or SAW based oscillators into LVPECL outputs for up to 800MHz of bandwidth. For greater bandwidth, refer to the [AZP63](#).

The [AZP51](#) is one of a family of parts that provide options of fixed $\div 1$, fixed $\div 2$ and selectable $\div 1$, $\div 2$ modes as well as active high enable or active low enable to oscillator designers. Refer to Table 2 for the comparison of parts within the AZP5x and AZP63 family.

BLOCK DIAGRAM

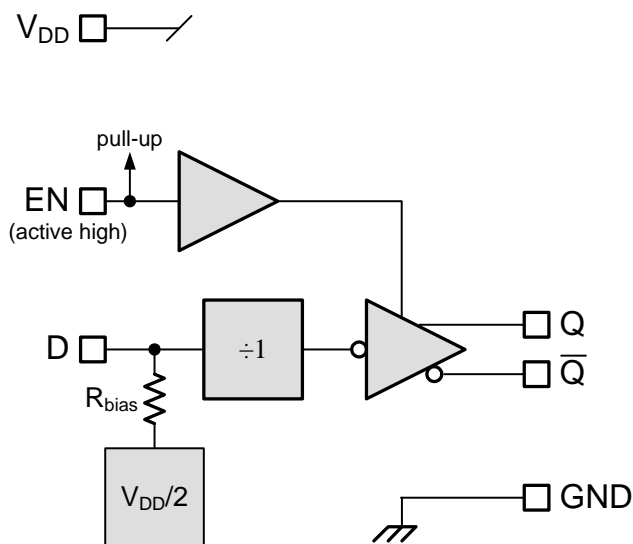

FEATURES

- LVPECL outputs optimized for very low phase noise (-165dBc/Hz)
- Up to 800MHz bandwidth
- Fixed $\div 1$ output
- 3.0V to 3.6V operation

APPLICATIONS

- PECL clock sources
- Crystal or SAW based oscillators with LVPECL output

PACKAGE AVAILABILITY

- SC70-6
 - Green/RoHS Compliant/Pb-Free

Order Number	Package	Marking
AZP51SG ¹	SC70-6	B <Date Code> ²

¹ [Tape & Reel](#) - Add 'R1' at end of order number for 7in (1k parts), 'R2' (2.5k) for 13in

² See www.azmicrotek.com for date code format

PIN DESCRIPTION AND CONFIGURATION

Table 1 - Pin Description

Pin	Name	Type	Function
1	V _{DD}	Power	Positive Supply
2	GND	Power	Negative Supply
3	D	Input	Sine or CMOS Input
4	EN	Input	Enable
5	\bar{Q}	Output	LVPECL Output
6	Q	Output	LVPECL Output

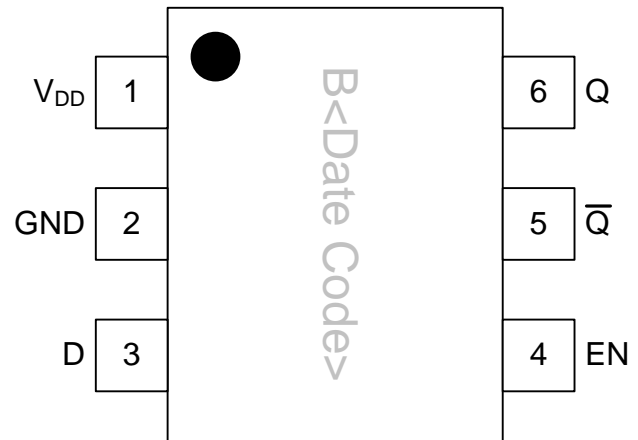

Figure 1 – Pin Configuration

ENGINEERING NOTES

FUNCTIONALITY

The AZP51 is one of a family of parts that provide options of fixed $\div 1$, fixed $\div 2$ and selectable $\div 1$, $\div 2$ modes as well as active high enable or active low enable to oscillator designers. Table 2 details the differences between the parts to assist designers in selecting the optimal part for their design.

Table 3 lists the specific AZP51 functional operation.

Figure 2 plots the S-parameters of the D input. [S-parameter](#) and [IBIS](#) model files for the AZP51 are also available for download.

Table 2 - AZP51-54 & AZP63 Family

Part Number	Divide Ratio	EN Logic	EN pull-up/pull-down	Bandwidth
AZP51	$\div 1$	active HIGH	Pull-up	> 800MHz
AZP52	$\div 2$	active HIGH	Pull-up	> 800MHz
AZP53	Selectable $\div 1$ or $\div 2$	selectable	selectable	> 800MHz
AZP54	$\div 1$	active LOW	Pull-down	> 800MHz
AZP63	Selectable $\div 1$ or $\div 2$	selectable	selectable	≥ 1 GHz

Table 3 - AZP51 Functional Operation

Part Number	Inputs		Outputs	
	EN	D	Q	\bar{Q}
AZP51	High, NC ¹	Low	Low	High
		High	High	Low
	Low	X ²	Z ³	Z ³

¹ Not connected

² Don't care

³ Tri-State

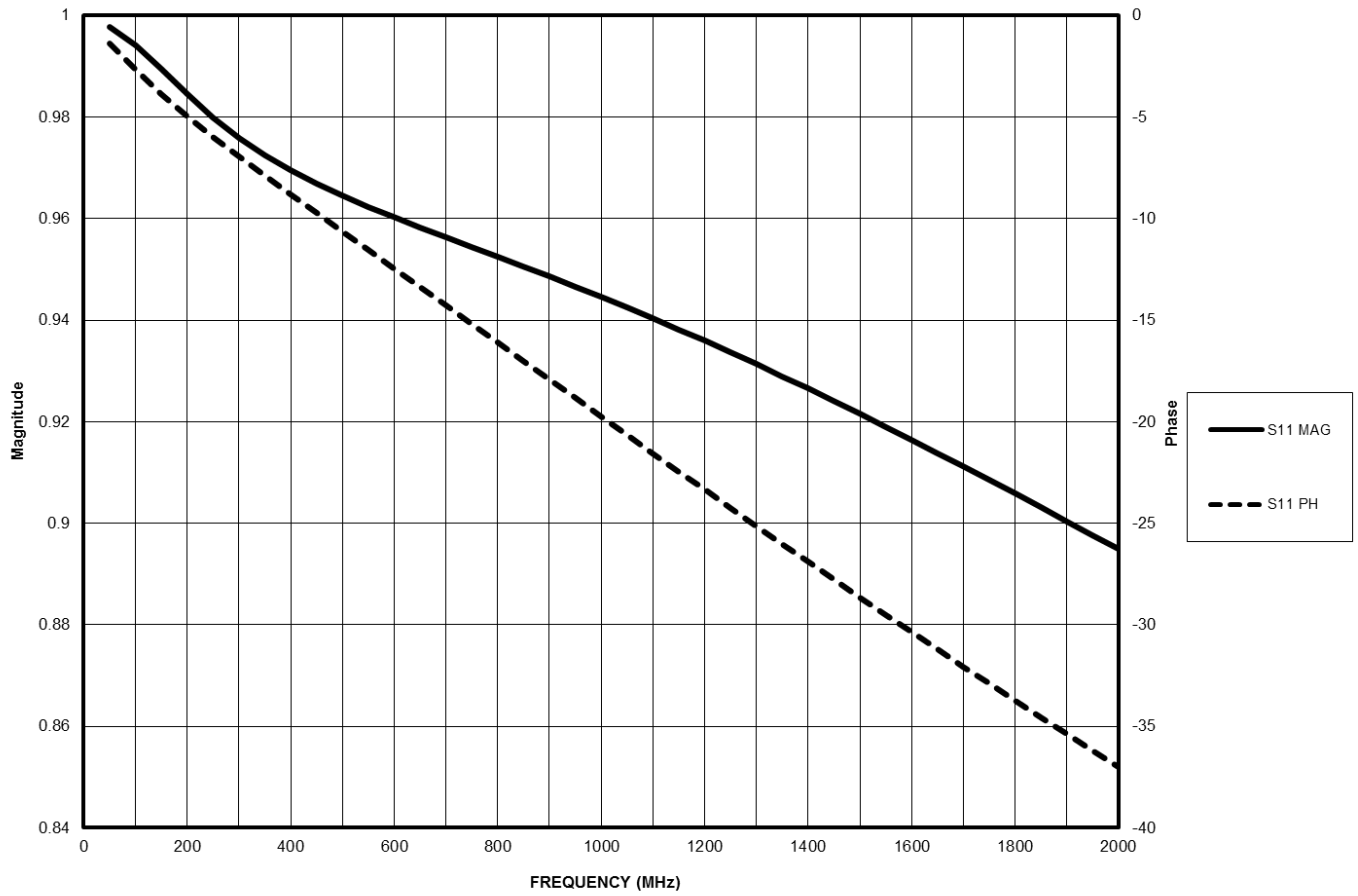

Figure 2- S11, Parameters, D Input

INPUT TERMINATION

The D input bias is $V_{DD}/2$ fed through an internal $10k\Omega$ resistor. For clock applications, an input signal of at least $750mV_{pp}$ ensures the AZP51 meets AC specifications. The input should also be AC coupled to maintain a 50% duty cycle on the outputs. The input can be driven to any voltage between 0V and V_{DD} without damage or waveform degradation.

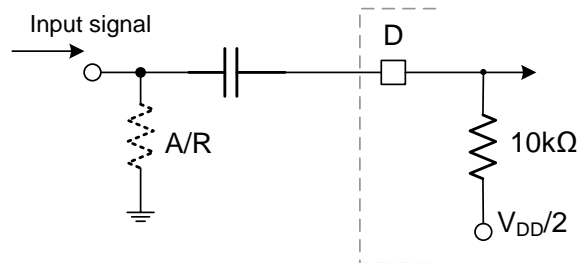

Figure 3 - Input Termination

OUTPUT TERMINATION TECHNIQUES

The LVPECL compatible output stage of the AZP51 uses a current drive topology to maximize switching speed as illustrated below in Figure 4. Two current source PMOS transistors (M1-M2) feed the output pins. M5 is an NMOS current source which is switched by M3 and M4. When M4 is on, M5 takes current from M2. This produces an output current of 5.1mA (low output state). M3 is off, and the entire 21.1mA flows through the output pin. The associated output voltage swings match LVPECL levels when external 50Ω resistors terminate the outputs.

Both Q and \bar{Q} should always be terminated identically to avoid waveform distortion and circulating current caused by unsymmetrical loads. This rule should be followed even if only one output is in use.

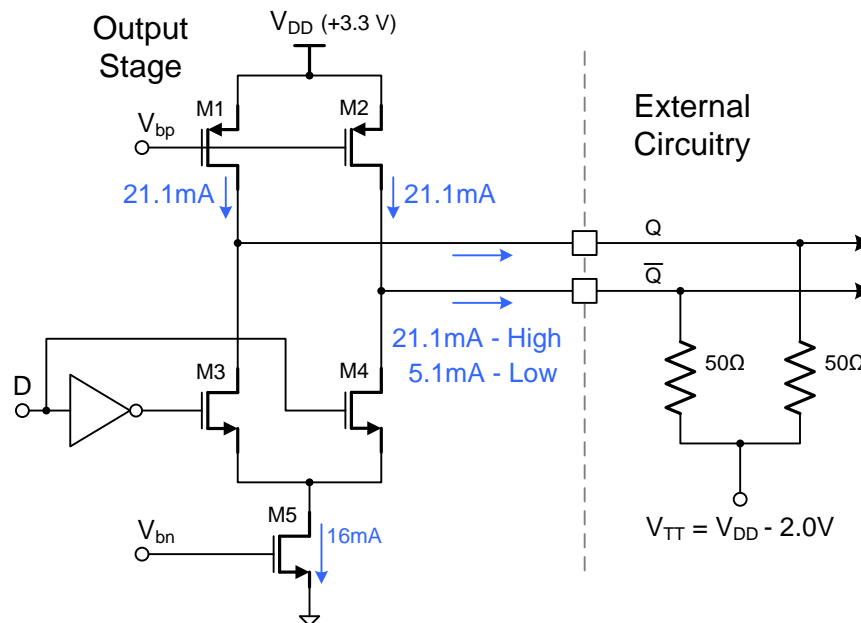

Figure 4 - Typical Output Termination

DUAL SUPPLY LVPECL OUTPUT TERMINATION

The standard LVPECL loads are a pair of 50Ω resistors connected between the outputs and $V_{DD}-2.0V$ (Figure 4). The resistors provide both the DC and the AC loads, assuming 50Ω interconnect. If an additional supply is available within the application, a four resistor termination configuration is possible (Figure 5).

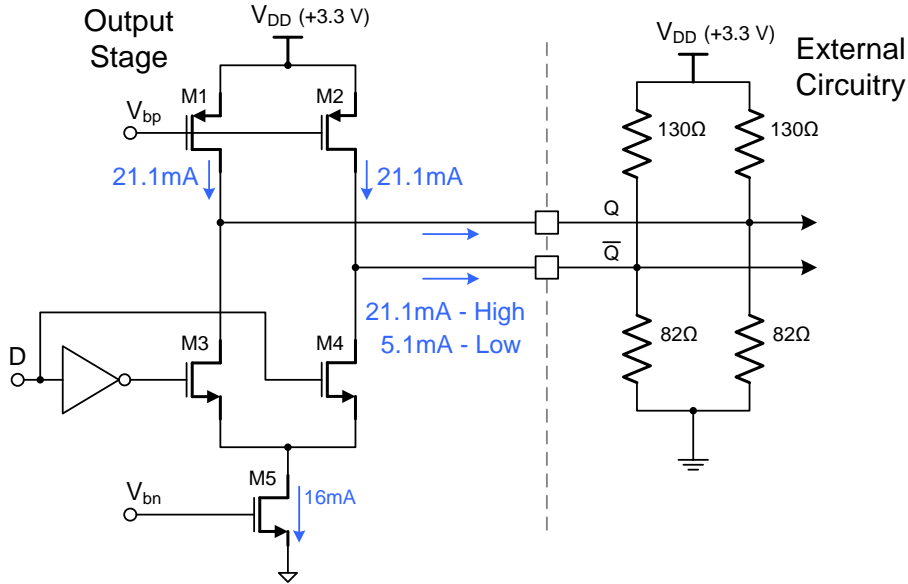

Figure 5 - Dual Supply Output Termination

THREE RESISTOR TERMINATION

Another termination variant eliminates the need for the additional supply (Figure 6). Alternately three resistors and one capacitor accomplish the same termination and reduce power consumption.

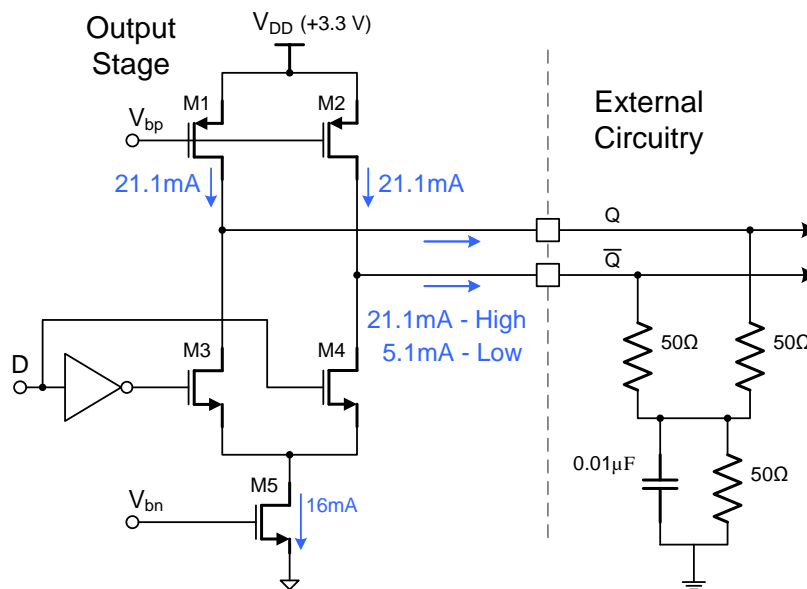

Figure 6 - Three Resistor Termination

EVALUATION BOARD (EBP53)

Arizona Microtek's evaluation board EBP53 provides the most convenient way to test and prototype AZP51 series circuits. Built for the AZP53Q 1.5x1.0 mm package, it is designed to support both dual and single supply operation. Dual supply operation ($V_{DD}=+2.0V$, $V_{SS}=-1.3V$) enables direct coupling to 50Ω time domain test equipment (Figure 7).

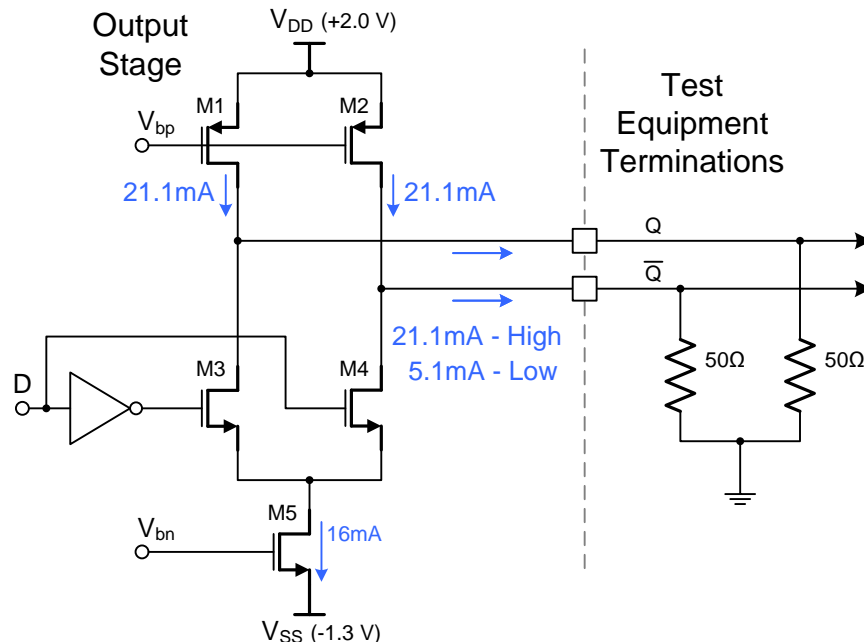

Figure 7 - Split Supply LVPECL Output Termination

AC TERMINATION

Clock applications or phase noise/frequency domain testing scenarios typically require AC coupling. Figure 8 below shows the AC coupling technique. The 200Ω resistors form the required DC loads, and the 50Ω resistors provide the AC termination. The parallel combination of the 200Ω and 50Ω resistors results in a net 40Ω AC load termination. In many cases this will work well. If necessary, the 50Ω resistors can be increased to about 56Ω. Alternately, bias tees combined with current setting resistors will eliminate the lowered AC load impedance. The 50Ω resistors are typically connected to ground but can be connected to the bias level needed by the succeeding stage.

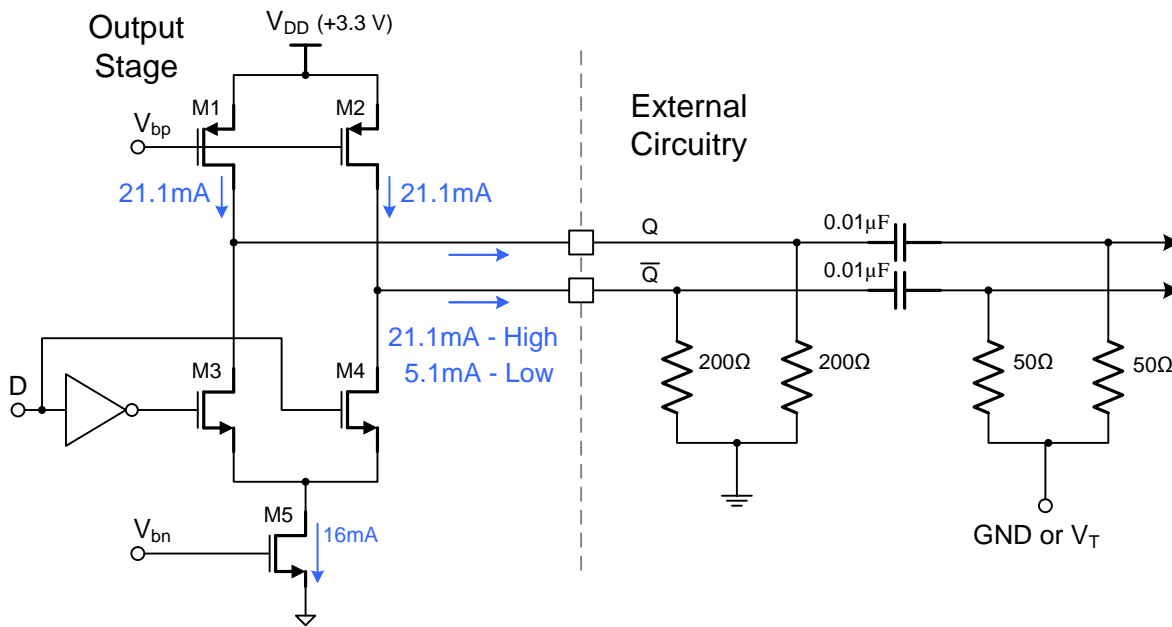

Figure 8 - AC Termination

PERFORMANCE DATA

Table 4 - Absolute Maximum Ratings

Absolute Maximum Ratings are those values beyond which device life may be impaired.

Symbol	Characteristic	Rating	Unit
V _{DD}	Power Supply	0 to +5.5	V
V _I	Input Voltage	-0.5 to V _{DD} + 0.5	V
T _A	Operating Temperature Range	-40 to +85	°C
T _{STG}	Storage Temperature Range	-65 to +150	°C
ESD _{HBM}	Human Body Model	2500	V
ESD _{MM}	Machine Model	200	V
ESD _{CDM}	Charged Device Model	2500	V

Table 5 - DC Characteristics

DC Characteristics ($V_{DD} = 3.0V$ to $3.6V$ unless otherwise specified, $T_A = -40$ to 85 °C)

Symbol	Characteristic	Conditions		Min	Typ	Max	Unit
V_{OH}	Output HIGH Voltage ¹	-40 C	$V_{DD} = 3.3V$	2.05		2.415	V
		25 C		2.05		2.48	
		85 C		2.05		2.54	
V_{OL}	Output LOW Voltage ¹	-40 C	$V_{DD} = 3.3V$	1.365		1.615	V
		25 C		1.43		1.68	
		85 C		1.49		1.74	
I_Z	Output Leakage Current, Tri-state ²	EN=Low		-10		10	μA
V_{IH}	High Level Input Voltage	EN		2			V
V_{IL}	Low Level Input Voltage	EN				0.8	V
I_{PD}	Pull-down Current	EN			-2.2		μA
R_{BIAS}	Bias Resistor	D Input to Internal $V_{DD}/2$ Reference			10k		Ω
I_{DD}	Power Supply Current				22	35	mA
I_{DDZ}	Power Supply Current	D Input $\leq V_{IL}$				8	mA
	Outputs Tri-state ¹	EN=Low					

¹ Specified with outputs terminated through 50Ω resistors to $V_{DD} - 2V$ or Thevenin equivalent.² Measured at Q / \bar{Q} pins.

Table 6 - AC Characteristics

AC Characteristics ($V_{DD} = 3.0V$ to $3.6V$, $T_A = -40$ to 85 °C)

AC Specifications guaranteed by design

Symbol	Characteristic	Min	Typ	Max	Unit
t_r / t_f	Output Rise/Fall ^{1,2}	80		250	ps
	(20% - 80%)				
f_{MAX}	Maximum Input Frequency - Sine wave ²			800	MHz
V_{INMAX}	Maximum Recommended Input Signal			V_{DD}	V _{pp}
V_{INMIN}	Minimum Recommended Input Signal	0.2			V _{pp}
t_{PLH}	Propagation Delay	938		1614	ps
t_{PHL}	Propagation Delay	938		1614	ps
J_{RMS}	RMS Jitter: 12kHz - 20MHz, 155MHz Center Freq		36		fs
n_p	Phase Noise ^{1,2} - 1MHz offset		-165		dBc/Hz

¹ Specified with outputs terminated through 50Ω resistors to $V_{CC} - 2V$ or Thevenin equivalent.² 1.5 v p-p sine wave input, AC coupled to D pin.

PACKAGE DIAGRAM
 SC70-6
 Green/RoHS compliant/Pb-Free
 MSL=1

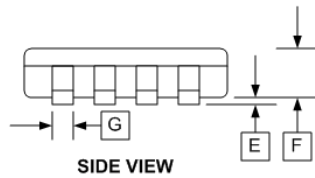
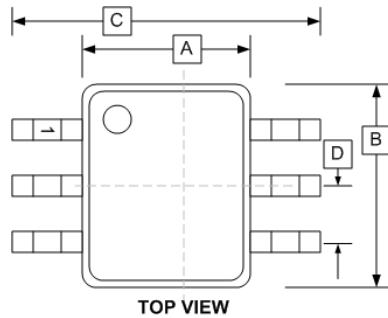

DIM	MILLIMETERS	
	MIN	MAX
A	1.15	1.35
B	1.85	2.25
C	2.00	2.30
D	0.65 BSC	
E	0.00	0.09
F	0.80	0.91
G	0.15	0.30
H	2.467	
I	0.08	0.25
J	0.21	0.41

SC70-6 (S)

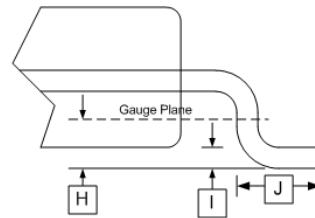

PCB LAND PATTERN/FOOTPRINT
 Dimensions in mm

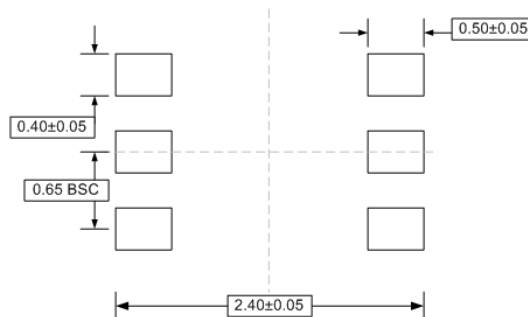

Arizona Microtek, Inc. reserves the right to change circuitry and specifications at any time without prior notice. Arizona Microtek, Inc. makes no warranty, representation or guarantee regarding the suitability of its products for any particular purpose, nor does Arizona Microtek, Inc. assume any liability arising out of the application or use of any product or circuit and specifically disclaims any and all liability, including without limitation special, consequential or incidental damages. Arizona Microtek, Inc. does not convey any license rights nor the rights of others. Arizona Microtek, Inc. products are not designed, intended or authorized for use as components in systems intended to support or sustain life, or for any other application in which the failure of the Arizona Microtek, Inc. product could create a situation where personal injury or death may occur. Should Buyer purchase or use Arizona Microtek, Inc. products for any such unintended or unauthorized application, Buyer shall indemnify and hold Arizona Microtek, Inc. and its officers, employees, subsidiaries, affiliates, and distributors harmless against all claims, costs, damages, and expenses, and reasonable attorney fees arising out of, directly or indirectly, any claim of personal injury or death associated with such unintended or unauthorized use, even if such claim alleges that Arizona Microtek, Inc. was negligent regarding the design or manufacture of the part.