

**FEATURES**

- InGaP HBT Technology
- High Efficiency:
  - 20 % @ +16 dBm P<sub>OUT</sub>
  - (without DC/DC Converter)
  - 40 % @ maximum P<sub>OUT</sub>
- Low Quiescent Current: 8 mA
- Internal Voltage Regulation
- Common V<sub>MODE</sub> Control Line
- Simplified V<sub>CC</sub> Bus PCB routing
- Reduced External Component Count
- Low Profile Surface Mount Package: 1 mm
- HSDPA Compliant
- RoHS Compliant Package, 250 °C MSL-3

**APPLICATIONS**

- WCDMA/HSPA 900/IMT Dual-Band Wireless Handsets and Data Devices

**PRODUCT DESCRIPTION**

The AWT6224 addresses the demand for increased integration in dual-band handsets for EGSM network deployments. The small footprint 3 mm x 5 mm x 1 mm surface mount RoHS compliant package contains independent RF PA paths to ensure optimal performance in both frequency bands, while achieving a 25% PCB space savings compared with solutions requiring two single-band PAs. The package pinout was chosen to enable handset manufacturers to easily route V<sub>CC</sub> to both power amplifiers and simplify control with a common V<sub>MODE</sub> pin. The device is manufactured on an advanced InGaP HBT MMIC technology offering state-of-the-art reliability, temperature stability, and ruggedness. The AWT6224 incorporates ANADIGICS' HELP3™ technology to provide low power consumption without the need for an external voltage regulator. Two operating modes provide optimum efficiency at high and medium/low power output levels, thereby dramatically increasing handset talk-time and standby-time. Its built-in voltage regulator eliminates the need for external voltage regulation and load switches. The 3 mm x 5 mm x 1 mm surface mount package incorporates matching networks optimized for output power, efficiency and linearity in a 50 Ω system.

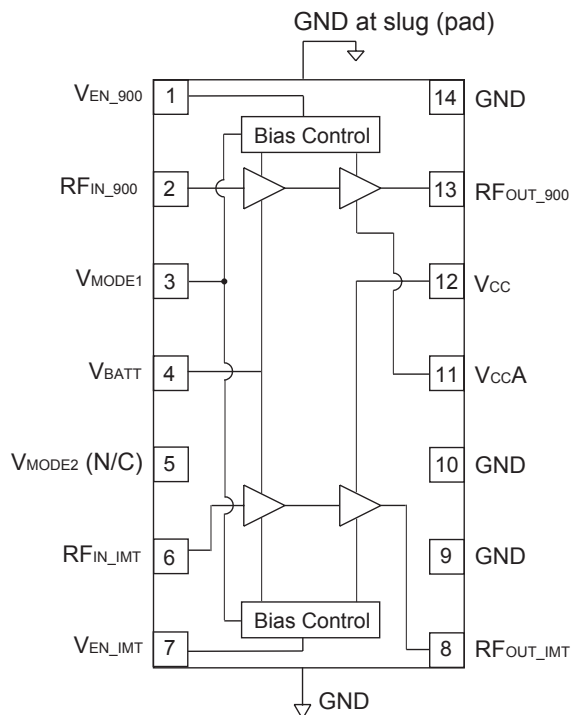
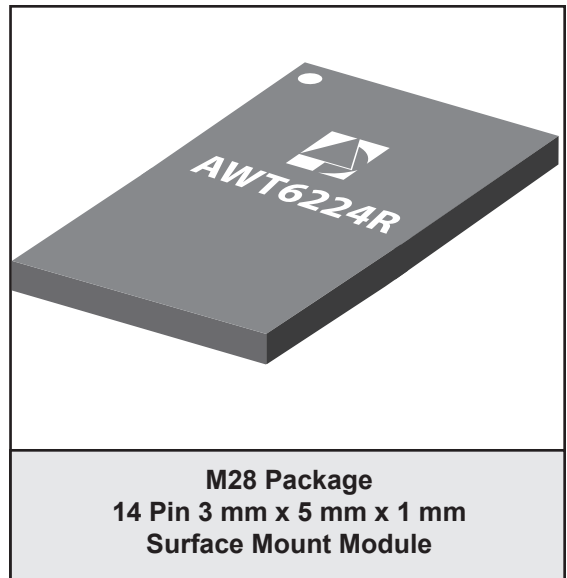
**Figure 1: Block Diagram**

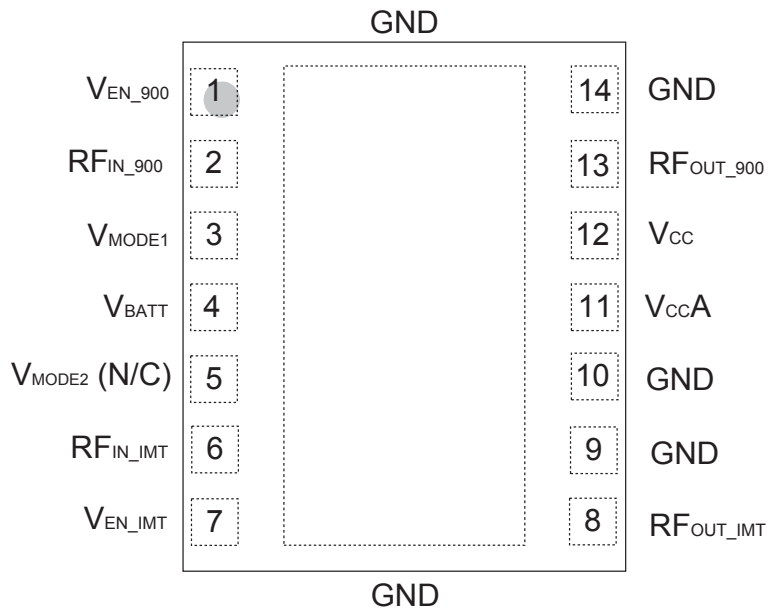

Figure 2: Pinout

Table 1: Pin Description

PIN	NAME	DESCRIPTION
1	$V_{EN\_900}$	Enable Voltage for 900 MHz Band
2	$RF_{IN\_900}$	RF Input for 900 MHz Band
3	$V_{MODE1}$	Mode Control Voltage 1
4	$V_{BATT}$	Battery Voltage
5	$V_{MODE2}$ (N/C)	No Connection
6	$RF_{IN\_IMT}$	RF Input for IMT Band
7	$V_{EN\_IMT}$	Enable Voltage for IMT Band
8	$RF_{OUT\_IMT}$	RF Output for IMT Band
9	GND	Ground
10	GND	Ground
11	$V_{CCA}$	Supply Voltage A
12	$V_{CC}$	Supply Voltage
13	$RF_{OUT\_900}$	RF Output for 900 MHz Band
14	GND	Ground

## ELECTRICAL CHARACTERISTICS

Table 2: Absolute Minimum and Maximum Ratings

PARAMETER	MIN	MAX	UNIT
Supply Voltage ( $V_{BATT}$ , $V_{CC}$ , $V_{CCA}$ )	0	+5	V
Mode Control Voltage ( $V_{MODE}$ )	0	+3.5	V
Enable Voltage ( $V_{EN\_CELL}$ , $V_{EN\_IMT}$ )	0	+3.5	V
RF Input Power ( $P_{IN}$ )	-	+10	dBm
Storage Temperature ( $T_{STG}$ )	-40	+150	°C

Stresses in excess of the absolute ratings may cause permanent damage. Functional operation is not implied under these conditions. Exposure to absolute ratings for extended periods of time may adversely affect reliability.

Table 3: Operating Ranges

PARAMETER	MIN	TYP	MAX	UNIT	COMMENTS
Operating Frequency (f)	880 1920	-	915 1980	MHz	EGSM IMT
Supply Voltage ( $V_{CC}$ and $V_{BATT}$ )	+3.2	+3.4	+4.2	V	
Enable Voltage ( $V_{EN}$ )	+2.2 0	+2.4 -	+3.1 +0.5	V	PA "on" PA "shut down"
Mode Control Voltage ( $V_{MODE}$ )	+2.2 0	+2.4 -	+3.1 +0.5	V	Low Bias Mode High Bias Mode
900 MHz Output Power ( $P_{OUT}$ ) R99 WCDMA, HPM HSPA (MPR=0), HPM R99 WCDMA, LPM HSPA (MPR=0), LPM	28.5 <sup>(1)</sup> 27.5 <sup>(1)</sup> 15.5 <sup>(1)</sup> 14.5 <sup>(1)</sup>	29 28 16 15	29 28 16 15	dBm	3GPP TS 34.121-1, Rel 7 Table C.11.1.3
IMT Output Power ( $P_{OUT}$ ) R99 WCDMA, HPM HSPA (MPR=0), HPM R99 WCDMA, LPM HSPA (MPR=0), LPM	28 <sup>(1)</sup> 27 <sup>(1)</sup> 15.5 <sup>(1)</sup> 14.5 <sup>(1)</sup>	28.5 27.5 16 15	28.5 27.5 16 15	dBm	3GPP TS 34.121-1, Rel 7 Table C.11.1.3
Case Temperature ( $T_C$ )	-20	-	+90	°C	

The device may be operated safely over these conditions; however, parametric performance is guaranteed only over the conditions defined in the electrical specifications.

Notes:

(1) For operation at  $V_{CC} = +3.2$  V,  $P_{OUT}$  is derated by 0.5 dB (all operating modes).

**Table 4: Electrical Specifications - 900 MHz Band**  
 (T<sub>c</sub> = +25 °C, V<sub>BATT</sub> = V<sub>CC</sub> = +3.4 V, V<sub>ENABLE</sub> = +2.4 V, 50 Ω system)

PARAMETER	MIN	TYP	MAX	UNIT	COMMENTS	
					P <sub>OUT</sub>	V <sub>MODE1</sub>
Gain	25.5 13.5	28 16	30.5 18.5	dB	+29 dBm +16 dBm	0 V 2.4 V
ACLR1 at 5 MHz offset <sup>(1)</sup>	- -	-41 -43	-37.5 -38	dBc	+29 dBm +16 dBm	0 V 2.4 V
ACLR2 at 10 MHz offset	- -	-62 -57	-48 -48	dBc	+29 dBm +16 dBm	0 V 2.4 V
Power-Added Efficiency <sup>(1)</sup>	37 17	40 20	- -	%	+29 dBm +16 dBm	0 V 2.4 V
Quiescent Current (I <sub>q</sub> )	-	8	13	mA	V <sub>MODE1</sub> = +2.4 V	
Mode Control Current	-	0.35	0.8	mA	through V <sub>MODE</sub> pin, V <sub>MODE</sub> = +2.4 V	
Enable Current	-	0.5	0.8	mA	through V <sub>ENABLE</sub> pin	
BATT Current	-	3	5	mA	through V <sub>BATT</sub> pin, V <sub>MODE1</sub> = +2.4 V	
Leakage Current	-	<1	5	μA	V <sub>BATT</sub> = +4.3 V, V <sub>CC</sub> = +4.3 V, V <sub>ENABLE</sub> = 0 V, V <sub>MODE1</sub> = 0 V	
Noise in Receive Band <sup>(2)</sup>	- -	-135 -140	-133 -138	dBm/Hz dBm/Hz	P <sub>OUT</sub> = +29 dBm, V <sub>MODE1</sub> = 0 V P <sub>OUT</sub> = +16 dBm, V <sub>MODE1</sub> = +2.4 V	
Harmonics 2fo 3fo, 4fo	- -	-44 -45	-30 -35	dBc	P <sub>OUT</sub> ≤ +29 dBm	
Input Impedance	-	-	2:1	VSWR		
Spurious Output Level (all spurious outputs)	-	-	-70	dBc	See note 3.	
Load mismatch stress with no permanent degradation or failure	8:1	-	-	VSWR	Applies over full operating range	

## Notes:

(1) ACLR and Efficiency measured at 897.5 MHz.

(2) 925 MHz to 960 MHz.

3. P<sub>OUT</sub> < +29 dBm, In-band load VSWR < 5:1, Out-of-band load VSWR < 10:1. Applies over all operating conditions.

**Table 5: Electrical Specifications - IMT Band**  
**(T<sub>C</sub> = +25 °C, V<sub>BATT</sub> = V<sub>CC</sub> = +3.4 V, V<sub>ENABLE</sub> = +2.4 V, 50 Ω system)**

PARAMETER	MIN	TYP	MAX	UNIT	COMMENTS	
					P <sub>OUT</sub>	V <sub>MODE1</sub>
Gain	25.0 12.0	27.5 14.0	30.0 16.5	dB	+28.5 dBm +16 dBm	0 V 2.4 V
ACLR1 at 5 MHz offset <sup>(1)</sup>	- -	-41 -43	-37.5 -37.5	dBc	+28.5 dBm +16 dBm	0 V 2.4 V
ACLR2 at 10 MHz offset	- -	-55 -56	-48 -48	dBc	+28.5 dBm +16 dBm	0 V 2.4 V
Power-Added Efficiency <sup>(1)</sup>	37 18	40 22	- -	%	+28.5 dBm +16 dBm	0 V 2.4 V
Quiescent Current (I <sub>cq</sub> ) Low Bias Mode	-	8	13	mA	V <sub>MODE1</sub> = +2.4 V	
Mode Control Current	-	0.35	0.8	mA	through V <sub>MODE</sub> pin, V <sub>MODE1</sub> = +2.4 V	
Enable Current	-	0.35	0.8	mA	through V <sub>ENABLE</sub> pin	
BATT Current	-	2.5	5	mA	through V <sub>BATT</sub> pin, V <sub>MODE1</sub> = 2.4 V	
Leakage Current	-	<1	5	μA	V <sub>BATT</sub> = +4.3 V, V <sub>CC</sub> = +4.3 V, V <sub>ENABLE</sub> = 0 V, V <sub>MODE1</sub> = 0 V	
Noise in Receive Band <sup>(2)</sup>	- -	-137 -144	-135 -139	dBm/Hz dBm/Hz	P <sub>OUT</sub> ≤ +28.5 dBm, V <sub>MODE1</sub> = 0 V P <sub>OUT</sub> ≤ +16 dBm, V <sub>MODE1</sub> = +2.4 V	
Harmonics 2fo 3fo, 4fo	- -	-37 -46	-30 -35	dBc		
Input Impedance	-	-	2:1	VSWR		
Spurious Output Level (all spurious outputs)	-	-	-70	dBc	See note 3.	
Load mismatch stress with no permanent degradation or failure	8:1	-	-	VSWR	Applies over full operating range	

## Notes:

(1) ACLR and Efficiency measured at 1950 MHz.

(2) Noise measured at 2110 to 2170 MHz.

3. P<sub>OUT</sub> < +28.5 dBm; In-band load VSWR < 5:1; Out-of-band load VSWR < 10:1; Applies over all operating conditions.

**APPLICATION INFORMATION**

To ensure proper performance, refer to all related Application Notes on the ANADIGICS web site: <http://www.anadigics.com>

**Shutdown Mode**

The power amplifier may be placed in a shutdown mode by applying logic low levels (see Operating Ranges table) to the  $V_{ENABLE}$  and  $V_{MODE1}$  pins.

**Bias Modes**

The power amplifier may be placed in either a Low Bias mode or a High Bias mode by applying the appropriate logic level (see Operating Ranges table) to  $V_{MODE1}$ .

The Bias Control table lists the recommended modes of operation for various applications.  $V_{MODE2}$  is not necessary for this PA.

Two operating modes are available to optimize current consumption. High Bias/High Power operating mode is for  $P_{OUT}$  levels > 16 dBm. At around 16 dBm output power, the PA should be “Mode Switched” to Medium/Low power mode for lowest quiescent current consumption.

**Table 6: Bias Control**

APPLICATION	$P_{OUT}$ LEVELS	BIAS MODE	$V_{ENABLE}$	$V_{MODE1}$	$V_{CC}$	$V_{BATT}$
UMTS - low power	$\leq +16$ dBm	Low	+2.4 V	+2.4 V	3.2 - 4.2 V	$\geq 3.2$ V
UMTS - high power	$> +16$ dBm	High	+2.4 V	0 V	3.2 - 4.2 V	$\geq 3.2$ V
OPTIONAL - low power	$\leq +7$ dBm	Low	+2.4 V	+2.4 V	1.5 - 3.2 V	$\geq 3.2$ V
Shutdown	-	Shutdown	0 V	0 V	3.2 - 4.2 V	$\geq 3.2$ V

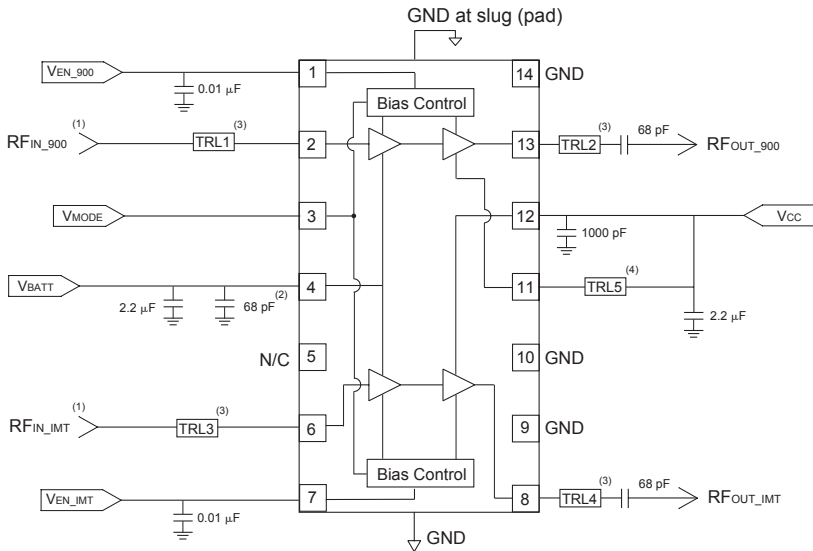

- Note:
- (1) Add blocking cap if DC voltage is present on input pin.
  - (2) 68 pF cap should be placed as close as possible to Pin 4.
  - (3) TRL should be short and of 50  $\Omega$  characteristic impedance.
  - (4) TRL 5 should be as long as possible (minimum of  $0.1 \lambda$  at 800 MHz) and capable of handling 750 mA current. Optional 4.7 nH coil may be substituted.

**Figure 3: Application Circuit**

PACKAGE OUTLINE

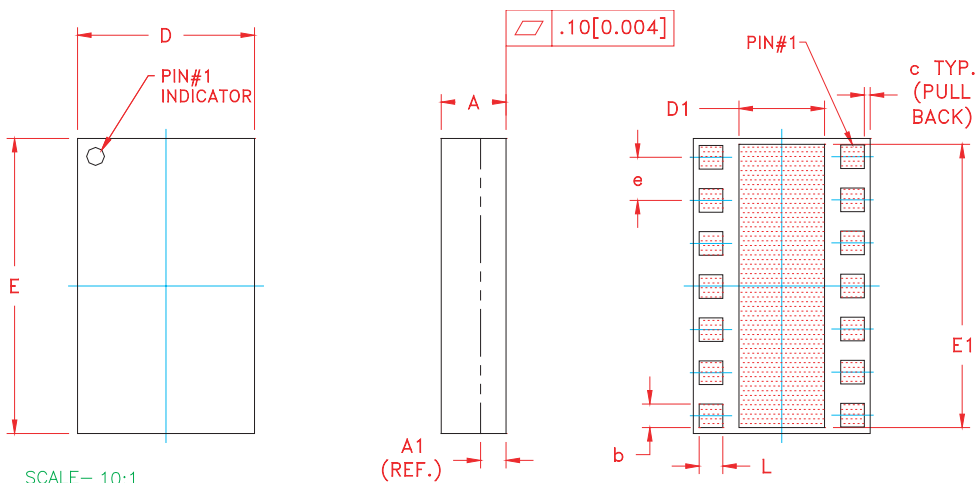

SYMBOL	MILLIMETERS			INCHES			NOTE
	MIN.	NOM.	MAX.	MIN.	NOM.	MAX.	
A	0.90	1.00	1.10	0.035	0.039	0.043	—
A1	0.35 (REF.)			0.014 (REF.)			—
b	0.37	—	0.57	0.015	—	0.022	3
c	—	0.10	—	—	0.004	—	—
D	2.88	3.00	3.12	0.113	0.118	0.123	—
D1	1.58	—	1.83	0.062	—	0.072	3
E	4.88	5.00	5.12	0.192	0.197	0.202	—
E1	4.75	—	4.85	0.187	—	0.190	3
e	—	0.73	—	—	0.029	—	4
L	0.33	—	0.52	0.013	—	0.020	3

NOTES:

1. CONTROLLING DIMENSIONS: MILLIMETERS
2. UNLESS SPECIFIED TOLERANCE=±0.076[0.003].
3. PADS (INCLUDING CENTER) SHOWN UNIFORM SIZE FOR REFERENCE ONLY. ACTUAL PAD SIZE AND LOCATION WILL VARY WITHIN MIN. AND MAX. DIMENSIONS ACCORDING TO SPECIFIC LAMINATE DESIGN.
4. PITCH MEASUREMENT (e) TAKEN CENTERLINE TO CENTERLINE OF SOLDER MASK OPENINGS.
5. UNLESS SPECIFIED DIMENSIONS ARE SYMMETRICAL ABOUT CENTER LINES SHOWN.

Figure 4: Package Outline - 14 Pin 3 mm x 5 mm x 1 mm Surface Mount Module

TOP BRAND



NOTES:

1. ANADIGICS LOGO SIZE: NONE
2. PART NUMBER: FOUR DIGIT NUMERICAL
3. WAFER LOT NUMBER: LLLLL = LOT NUMBER  
NN = WAFER I.D.
4. PIN 1 INDICATOR: LASER DOT
5. B.O.M. # BBBB
6. COUNTRY CODE: CC = TH-for-THAILAND, TW-for-TAIWAN  
CC = PH-for-PHILIPPINES, CH-for-CHINA
7. YEAR & WORK WEEK YY = YEAR, WW = WORK WEEK
8. TYPE : ARIAL  
SIZE : 1.5-POINT  
COLOR : LASER

Figure 5: Branding Specification

## ORDERING INFORMATION

ORDER NUMBER	TEMPERATURE RANGE	PACKAGE DESCRIPTION	COMPONENT PACKAGING
AWT6224RM28Q7	-20 °C to +90 °C	RoHS Compliant 14 Pin 3 mm x 5 mm x 1 mm Surface Mount Module	Tape and Reel, 2500 pieces per Reel
AWT6224RM28P9	-20 °C to +90 °C	RoHS Compliant 14 Pin 3 mm x 5 mm x 1 mm Surface Mount Module	Partial Tape and Reel

**ANADIGICS, Inc.**

141 Mount Bethel Road  
Warren, New Jersey 07059, U.S.A.

Tel: +1 (908) 668-5000

Fax: +1 (908) 668-5132

URL: <http://www.anadigics.com>

E-mail: [Mktg@anadigics.com](mailto:Mktg@anadigics.com)

**IMPORTANT NOTICE**

ANADIGICS, Inc. reserves the right to make changes to its products or to discontinue any product at any time without notice. The product specifications contained in Advanced Product Information sheets and Preliminary Data Sheets are subject to change prior to a product's formal introduction. Information in Data Sheets have been carefully checked and are assumed to be reliable; however, ANADIGICS assumes no responsibilities for inaccuracies. ANADIGICS strongly urges customers to verify that the information they are using is current before placing orders.

**WARNING**

ANADIGICS products are not intended for use in life support appliances, devices or systems. Use of an ANADIGICS product in any such application without written consent is prohibited.