

FEATURES

- Usable to 1 GHz
- High Linearity: 65 dBc CTB/CSO (79 Chan.)
- Low Equivalent Input Noise: 4.5 pA/rHz
- 20 dB Gain Adjust
- 400 Ω Differential Input Impedance: No Transformer Required for Interface to Photodiode
- Single +5 V Supply
- 5 mm x 5 mm x 1 mm Surface Mount Package
- RoHS Compliant Package
- Pin Compatible with the ACA2601

APPLICATIONS

- FTTH RF Amplifier Used in Conjunction With Triplexer in Fiber-Coax Line Terminals
- Post photodiode RF Amplifier in FTTB video receivers for Multiple Dwelling Units (MDUs).



PRODUCT DESCRIPTION

The ANADIGICS ACA2604 amplifier is intended to be used in fiber-to-coax equipment, such as ONUs for FTTH systems incorporating RF overlay, or FTTB optical receivers for MDUs. The device is driven by, and amplifies the output of, the video downstream path photodiode.

The high-impedance input of the ACA2604 eliminates the need for a costly transformer usually needed to interface to the photodiode, and a low equivalent input noise level offers excellent sensitivity. The device

provides sufficient linearity to maintain low CTB and CSO levels in full-bandwidth (132 channel) systems, even across a wide gain adjustment range.

The ACA2604 is manufactured using ANADIGICS's proven MESFET technology that offers state-of-the-art reliability, temperature stability and ruggedness. The device operates from a single +5 V supply and is offered in a 5 mm x 5 mm x 1 mm surface mount package.

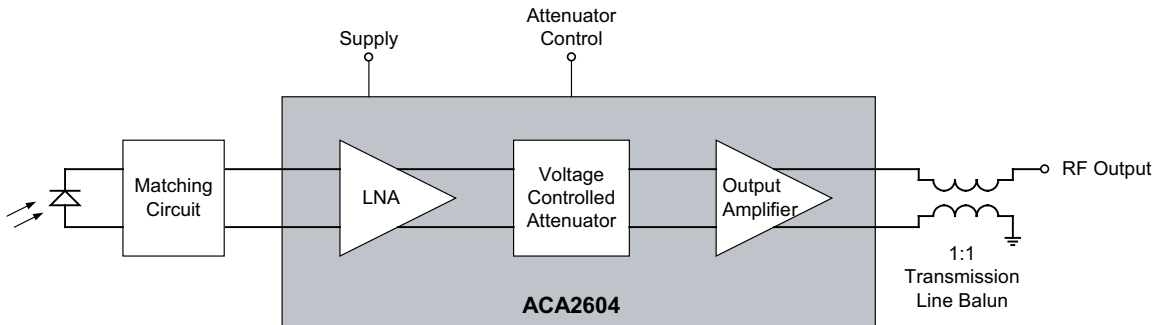

Figure 1: Application Block Diagram

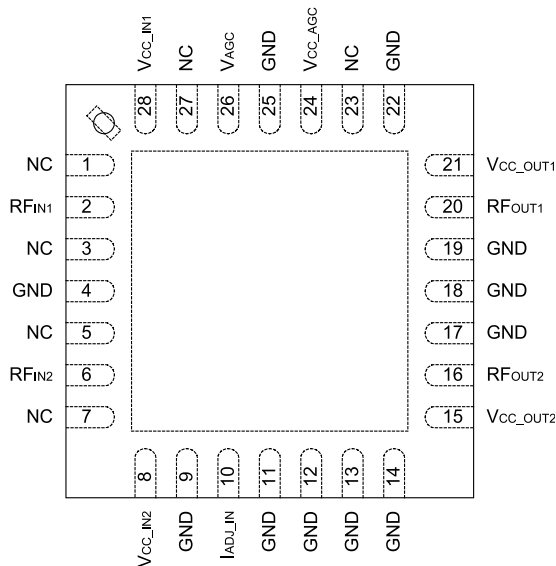

Figure 2: Pinout (X-ray Top View)

Table 1: Pin Description

PIN	NAME	DESCRIPTION	PIN	NAME	DESCRIPTION
1	NC	No Connection	28	V _{CC_IN1}	Input Stage Supply 1
2	RF _{IN1}	RF Input 1	27	NC	No Connection
3	NC	No Connection	26	V _{AGC}	AGC Control Input
4	GND	Ground	25	GND	Ground
5	NC	No Connection	24	V _{CC_AGC}	AGC Supply
6	RF _{IN2}	RF Input 2	23	NC	No Connection
7	NC	No Connection	22	GND	Ground
8	V _{CC_IN2}	Input Stage Supply 2	21	V _{CC_OUT1}	Output Stage Supply 1
9	GND	Ground	20	RF _{OUT1}	RF Output 1
10	I _{ADJ_IN}	Input Stage Current Adjust	19	GND	Ground
11	GND	Ground	18	GND	Ground
12	GND	Ground	17	GND	Ground
13	GND	Ground	16	RF _{OUT2}	RF Output 2
14	GND	Ground	15	V _{CC_OUT2}	Output Stage Supply 2

ELECTRICAL CHARACTERISTICS

Table 2: Absolute Minimum and Maximum Ratings

PARAMETER	MIN	MAX	UNIT	COMMENTS
Supply Voltage (V_{CC})	0	+8	V	
RF Input Power	-	+40	dBmV	per channel 132 channel loading
ESD Rating	500 1000	- -	V	Human Body Model, Class 1B Charged Device Model, Class 3
MSL Level	2-260	-	-	

Stresses in excess of the absolute ratings may cause permanent damage. Functional operation is not implied under these conditions. Exposure to absolute ratings for extended periods of time may adversely affect reliability.

Table 3: Operating Ranges

PARAMETER	MIN	TYP	MAX	UNIT	COMMENTS
Operating Frequency (f)	50	-	1000	MHz	
Supply Voltage (V_{CC})	-	+5	-	V	
RF Output Power (P_{OUT})	-	+18	-	dBmV/ch	
Case Temperature (T_C)	-40	-	+110	°C	

The device may be operated safely over these conditions; however, parametric performance is guaranteed only over the conditions defined in the electrical specifications.

Table 4: Electrical Specifications - RF_{IN} and RF_{OUT} Characterizations (see Figure 3)
(V_{CC} = +5 V, 75 Ω system, T_A = +25 °C)

PARAMETER	MIN	TYP	MAX	UNIT	COMMENTS
RF Gain over Temperature ⁽¹⁾	22.5	24.0	-	dB	at 547.25 MHz
CTB ⁽²⁾	-	-65	-60	dBc	
CSO ⁽²⁾	-	-65	-59	dBc	
Input Impedance	-	400	-	Ω	differential
Current Consumption	-	230	295	mA	
Thermal Resistance	-	18	25	°C/W	

Notes:

(1) Temperature range of -30 to +100 °C referenced to the package slug.

(2) 79 analog channels from 55.25 to 547.25 MHz, +21 dBmV output power, with 14 dB gain reduction by AGC

Table 5: Electrical Specifications - Optical in and RF_{OUT} Characterizations
(V_{CC} = +5 V, optical input, 75 Ω output, T_A = +25 °C, frequency ranges 55.25 to 865.25 MHz)

PARAMETER	MIN	TYP	MAX	UNIT	COMMENTS
Tilt @ V _{AGC} = 1.6 V	4	-	5.6	dB	
Gain Flatness @ V _{AGC} = 1.6 V	-	-	2	dB	
Output Return Loss over Temperature -30 °C to +85 °C +85 °C to +100 °C	16 15	18 -	- -	dB	
Attenuator Adjustment Range	18	20	-	dB	V _{AGC} = 0.5 V to 3.0 V
Equivalent Input Noise (EIN)	-	4.5	5.5	pA/rt Hz	
Equivalent Input Noise over Temperature	-	5.0	-	pA/rt Hz	Temperature range of -30 to +100 °C

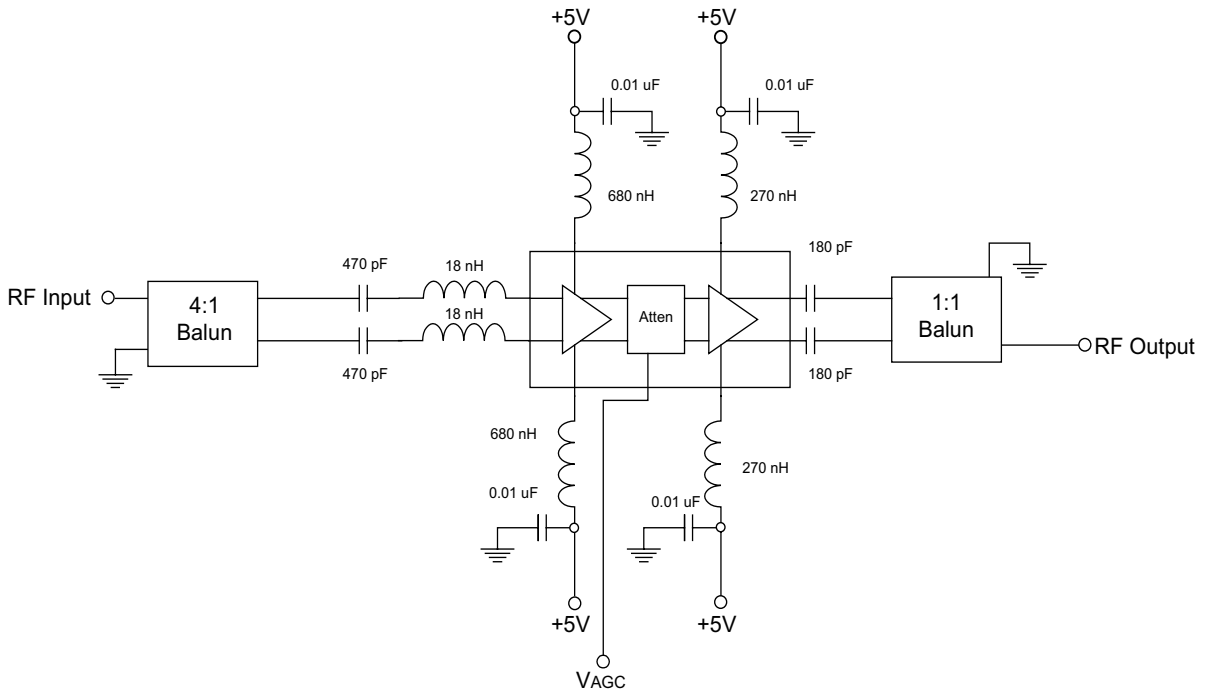

Figure 3: Test Circuit

PERFORMANCE DATA

Performance data on this page measured using application circuit with input photodiode, as shown in Figure 11.

Figure 4: Z21 vs. Frequency over V_{AGC}
(T_A = +25 °C, V_{CC} = + 5 V)

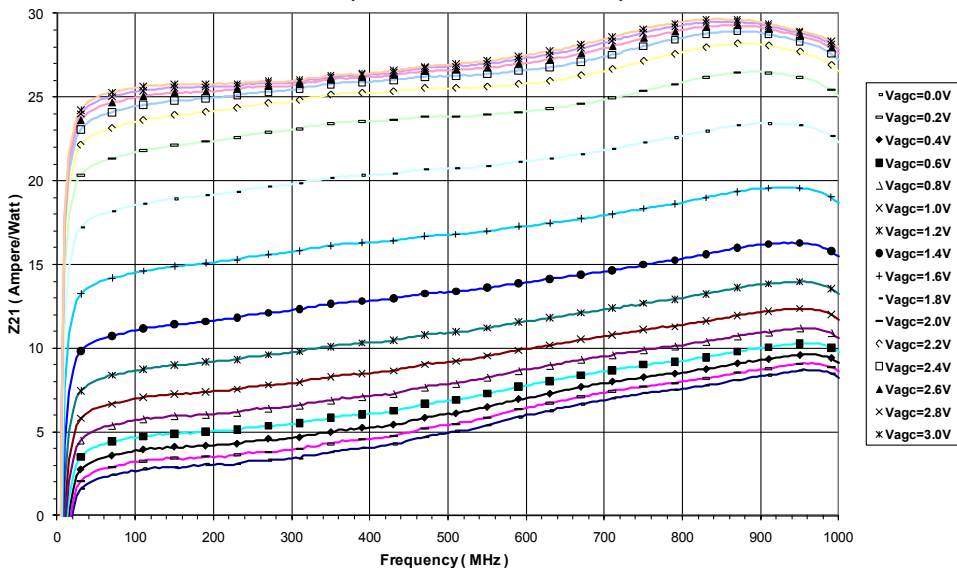
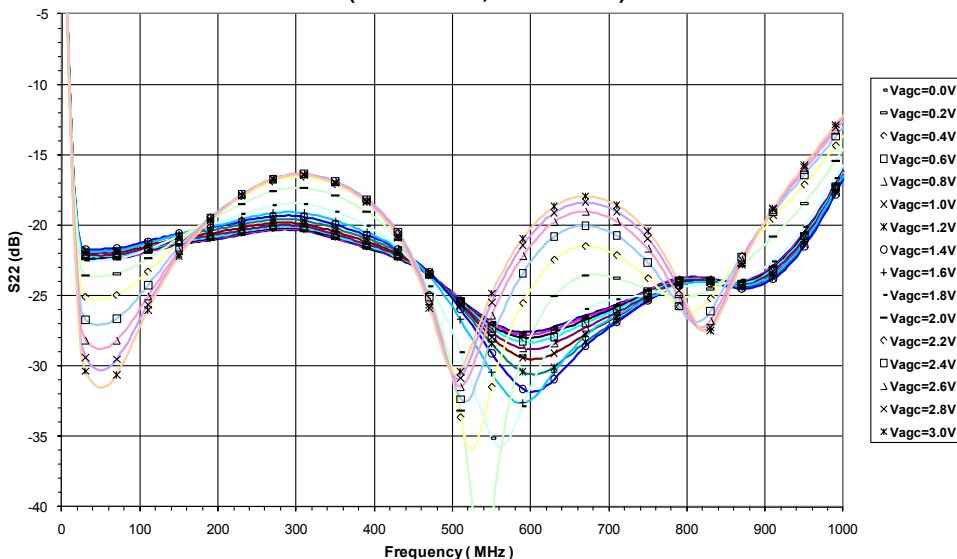

Figure 5: Output Return Loss vs. Frequency over V_{AGC}
(T_A = +25 °C, V_{CC} = + 5 V)



Performance data on this page measured using test circuit shown in Figure 3.

Figure 6: CTB vs. Frequency
 (79 Analog channels (55.25 to 547.25 MHz), +21 dBmV output power, with 14 dB gain reduction by AGC)

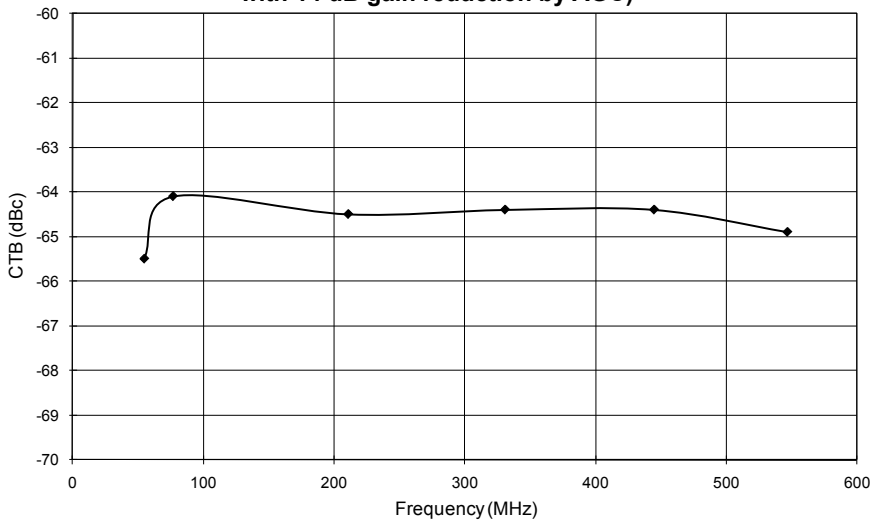
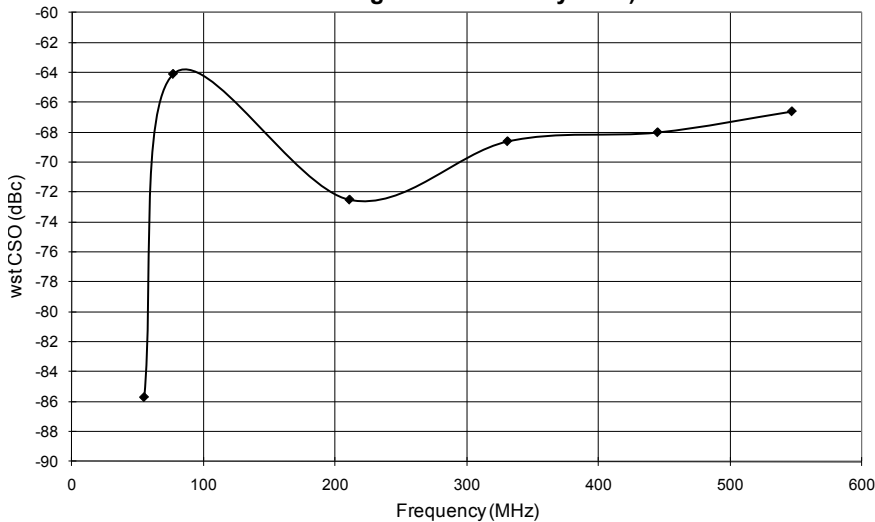

Figure 7: Worst Case CSO vs. Frequency
 (79 Analog channels (55.25 to 547.25 MHz), +21 dBmV output power, with 14 dB gain reduction by AGC)



Performance data on this page measured using application circuit with input photodiode, as shown in Figure 11.

Figure 8: CTB vs. Frequency vs. P_{OPT}
 (79 Analog channels (55.25 to 547.25 MHz), +17 dBmV at 109.25 MHz, 3.5% OMI/ch)

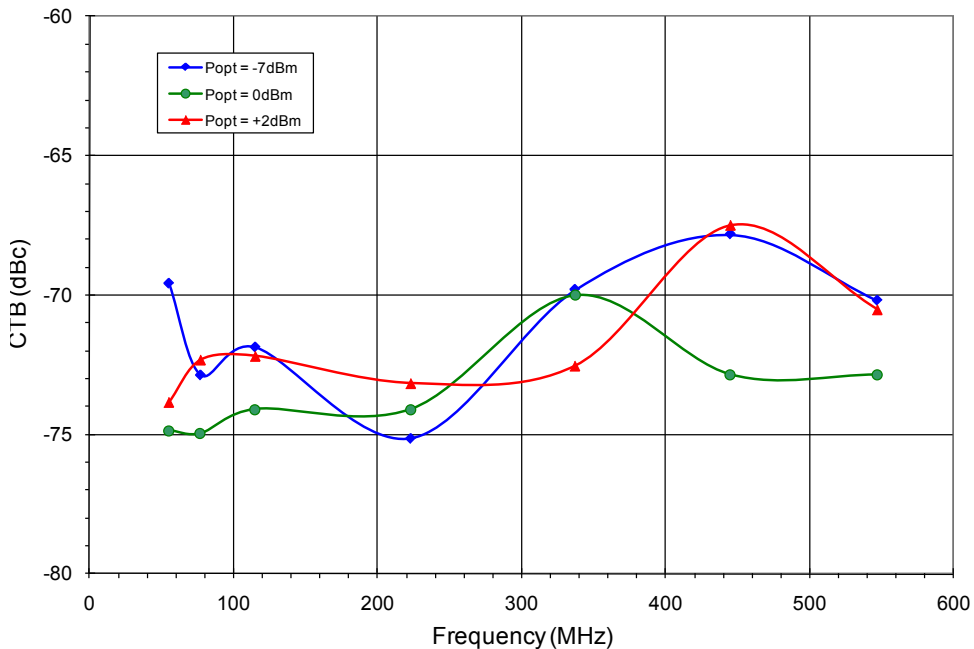
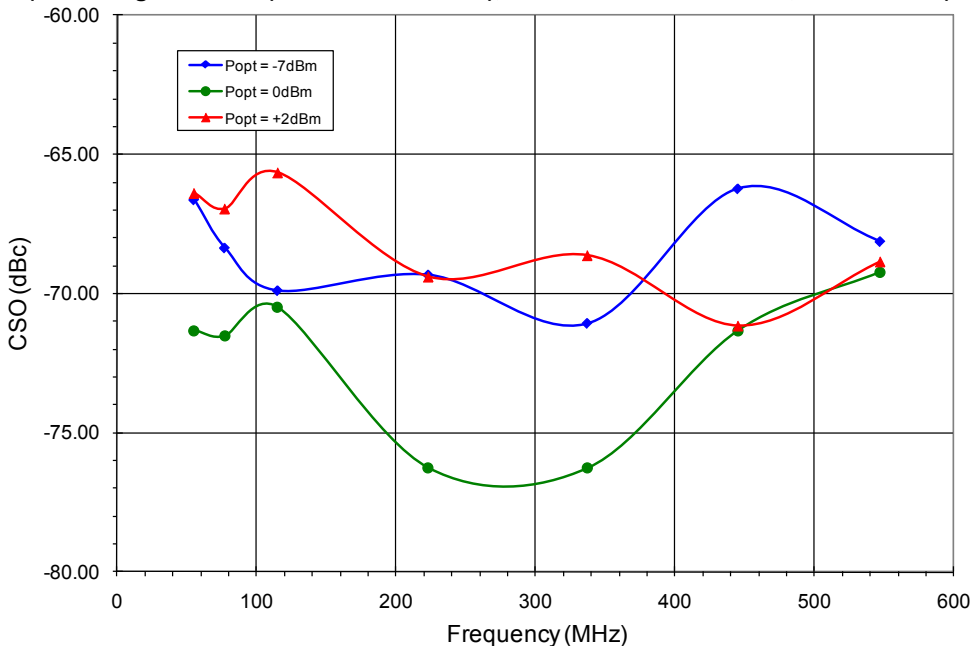
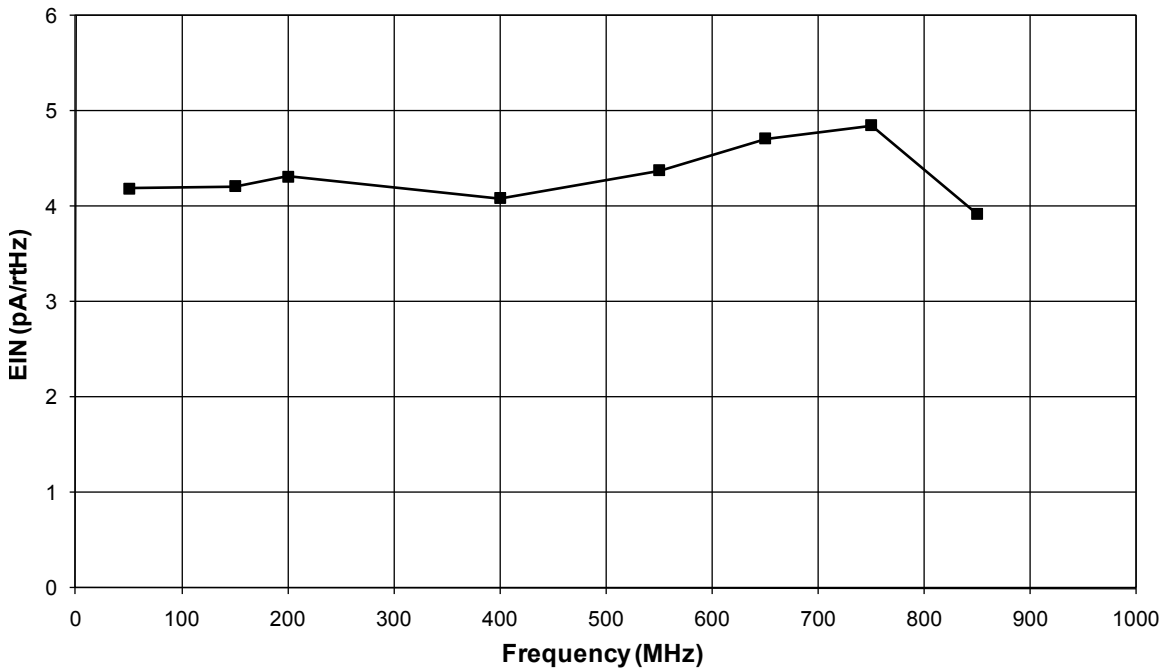

Figure 9: CSO vs. Frequency vs. P_{OPT}
 (79 Analog channels (55.25 to 547.25 MHz), +17 dBmV at 109.25 MHz, 3.5% OMI/ch)



Performance data on this page measured using application circuit with input photodiode, as shown in Figure 11.

Figure 10: Equivalent Input Noise vs. Frequency
(TA = 25 °C, VCC = +5 V, VAGC = +3.0 V)



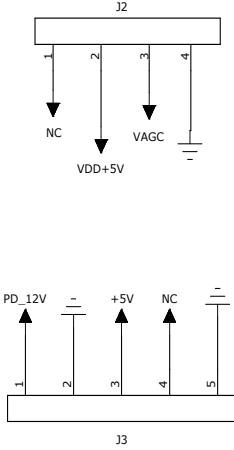
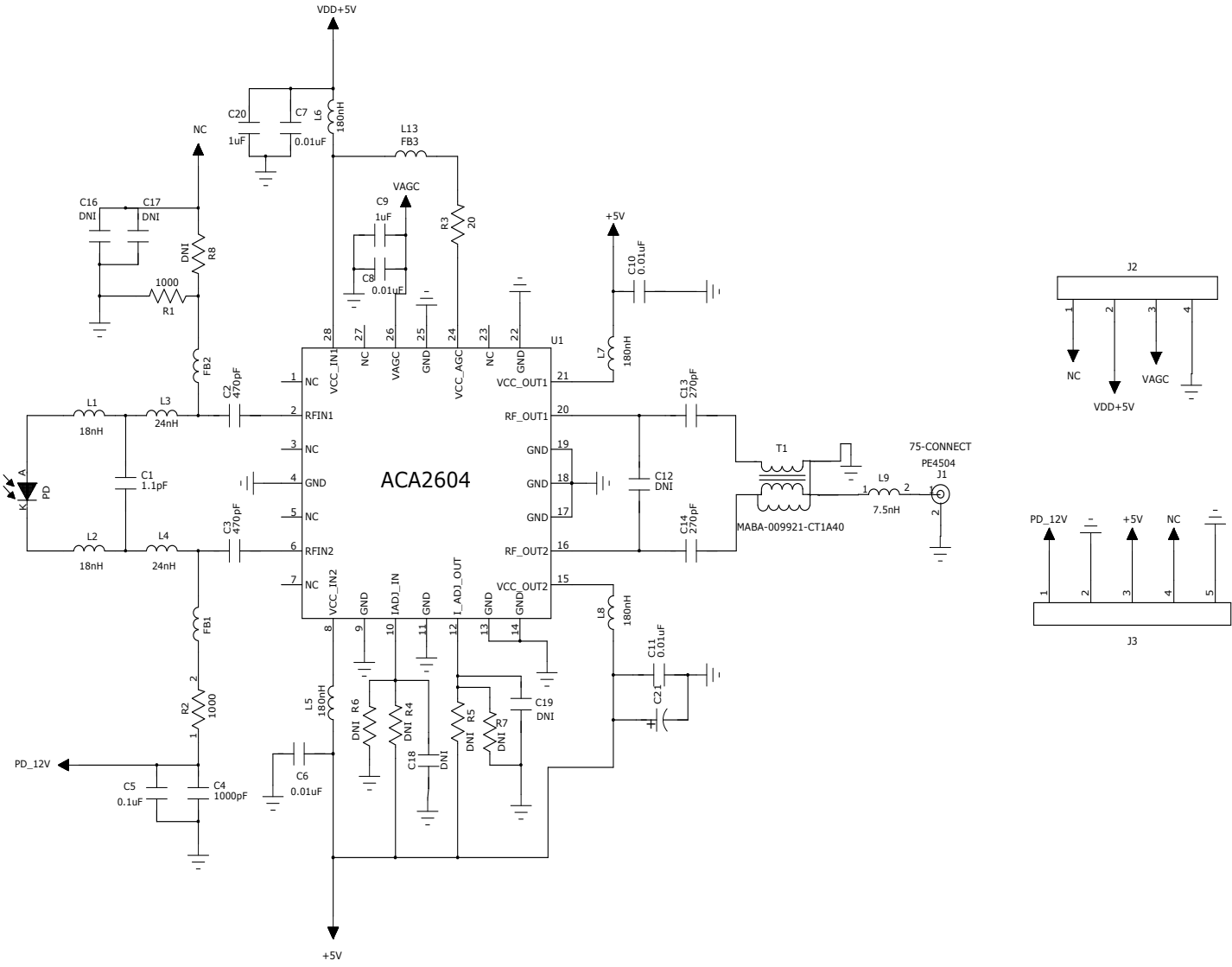

Figure 11: Application Circuit

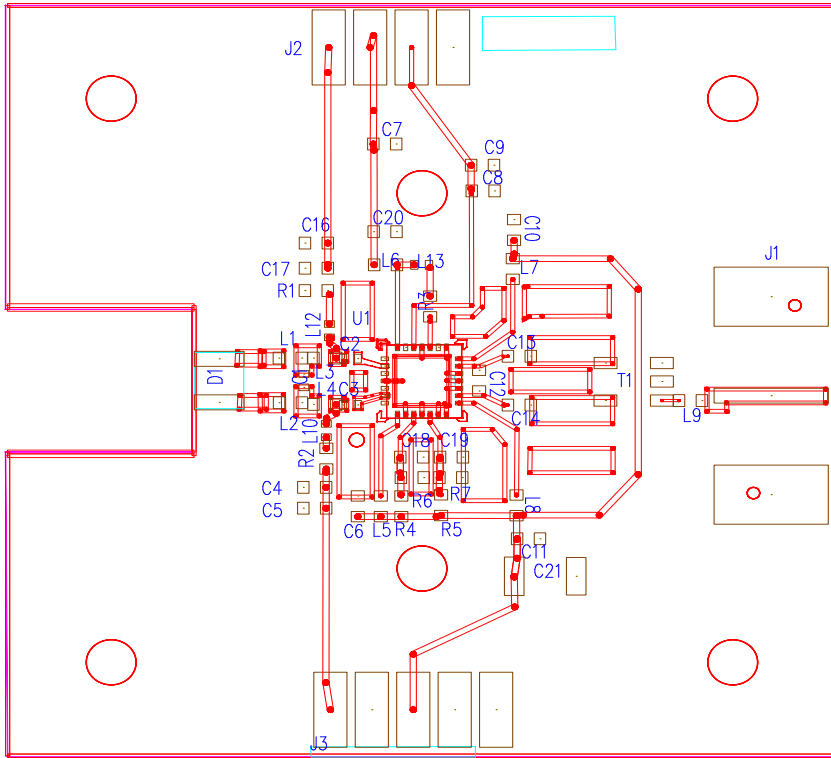
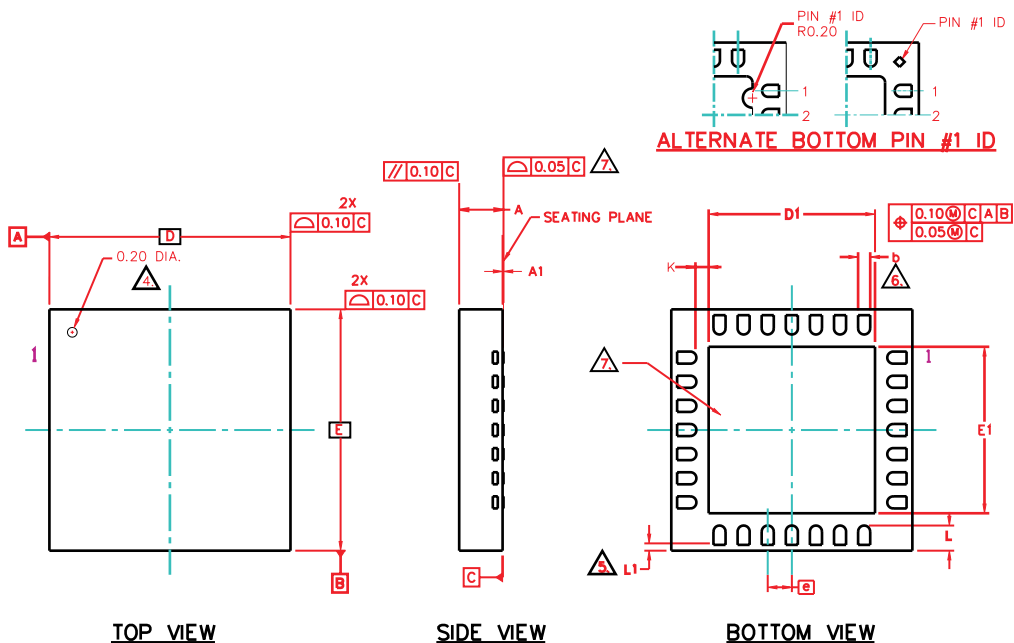

Figure 12: Evaluation Board Layout

Table 9: Evaluation Board Parts List for 50 - 1000 MHz Applications

REF	DESCRIPTION	QTY	VALUE	VENDOR	VENDOR PART NO.
C1	CHIP CAP 0402	1	1.1pF	MURATA ELECTRONICS	GRM1555C1H1R1JZ01
C2-C3	CHIP CAP 0402	2	470pF	MURATA ELECTRONICS	GRM1555C1H471GA01
C4	CHIP CAP 0603	1	1000pF	MURATA ELECTRONICS	GRM1885C1H102JA01D
C5	CHIP CAP 0603	1	0.1uF	MURATA ELECTRONICS	GRM188F51C104ZA01D
C6-C7-C8-C10-C11	CHIP CAP 0603	5	0.01uF	MURATA ELECTRONICS	GRM1885C1HR50CZ01D
C9-C20	CHIP CAP 0603	2	1uF	MURATA ELECTRONICS	GRM188R61C105KA93D
C13-C14	CHIP CAP 0603	2	270pF	MURATA-ELECTRONICS	GRM155R7H271KA01D
C21	ELECTROLITIC CAP	1	47uF	PANASONIC-ACG	ECA-1EM470B
L10-L12	EMI FERRITE CHIP	2		MURATA ELECTRONICS	BLM15HD182SN
L13	EMI FERRITE CHIP	1		MURATA ELECTRONICS	BLM15HG102SN1D
L1-L2	INDUCTOR 0603HP	2	18nH	COILCRAFT	0603HP-18NX_L
L3-L4	INDUCTOR 0603HP	2	24nH	COILCRAFT	0603HP-24NX_L
L5-L6-L7-L8	INDUCTOR 0603LS	4	180nH	COILCRAFT	0603LS-181X_L
L9	CHIP INDUCTOR 0603	1	7.5nH	MURATA	LQG18HN7N5J00
D1	ANALOG PHOTODIODE	1		EGTRAN	PD070-HL1-300 or PD070-HL2-300
R1-R2	CHIP RESISTOR 0603	2	1000	PANASONIC-ECG	ERJ-2GEJ102X
R3	CHIP RESISTOR 0603	1	20	PANASONIC-ECG	ERT-3GEYJ200W
T1	1:1 BALUN TRANS- FORMER	1		M/A-COM	MABA-009921-CT1A40
J1	75 OHMS, N-MALE TYPE CONNECTOR	1		PASTERNAK INTER- PRISES	PE4504
J2	END LAUNCH	1			
J3	END LAUNCH	1			
U1	ACA2604 IC	1		Anadigics	ACA2604

PACKAGE OUTLINE



NOTES :

1. ALL DIMENSIONS ARE IN MILLIMETERS.
 2. MAX. PACKAGE WARPAGE IS 0.05 mm.
 3. MAXIMUM ALLOWABLE BURRS IS 0.076 mm IN ALL DIRECTIONS.
- ⚠ PIN #1 ID ON TOP WILL BE LASER MARKED.
 - ⚠ A MAXIMUM 0.15mm PULL BACK (L1) MAYBE PRESENT. L MINUS L1 TO BE EQUAL TO OR GREATER THAN 0.30mm.
 - ⚠ DIMENSION b APPLIES TO METALLIZED TERMINAL AND IS MEASURED BETWEEN 0.15 AND 0.30mm FROM TERMINAL TIP. IF THE TERMINAL HAS THE OPTIONAL RADIUS ON THE OTHER END OF THE TERMINAL, THE DIMENSION b SHOULD NOT BE MEASURED IN THAT RADIUS AREA.
 - ⚠ BILATERAL COPLANARITY ZONE APPLIES TO THE EXPOSED HEAT SINK SLUG AS WELL AS THE TERMINALS.
 - 8. REFERENCE JEDEC OUTLINE MO-220.

Symbol	DIMENSIONS—MM		Symbol	DIMENSIONS—INCHES	
	MIN.	MAX.		MIN.	MAX.
A	0.80	1.00	A	0.031	0.039
A1	0.00	0.05	A1	0.000	0.002
b	0.18	0.30	b	0.007	0.012
D	5.00 BSC		D	0.197 BSC	
D1	3.30	3.55	D1	0.130	0.140
E	5.00 BSC		E	0.197 BSC	
E1	3.30	3.55	E1	0.130	0.140
K	0.50 BSC		K	0.020 BSC	
L	0.20 MIN.		L	0.007 MIN.	
L1	0.30	0.57	L1	0.012	0.022
L1	0.15 MAX.		L1	0.006 MAX.	

Figure 13: S29 Package Outline - 28 Pin 5 mm x 5 mm x 1 mm QFN

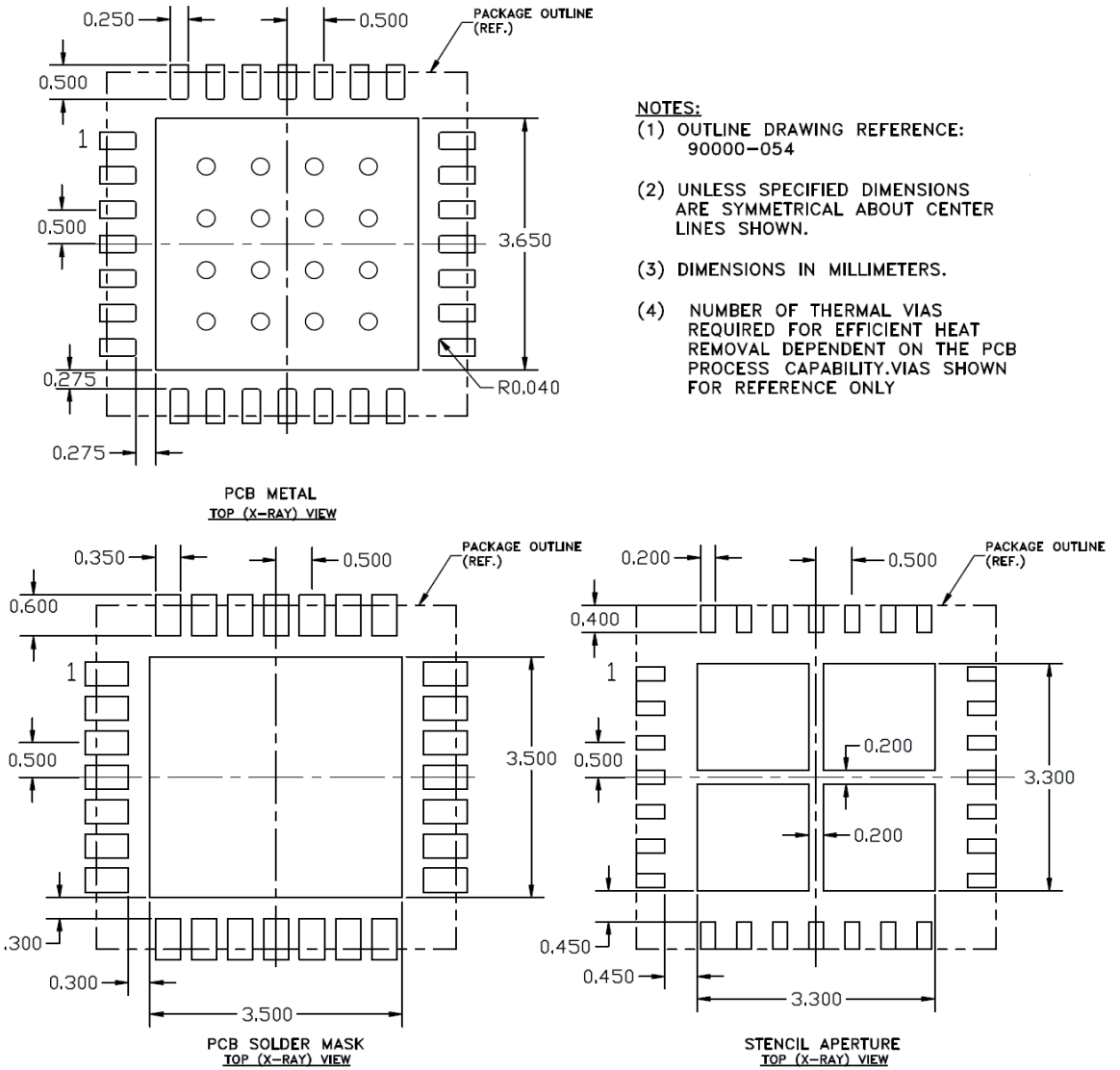

Figure 14: PCB Metal and Solder Mask Details

ORDERING INFORMATION

ORDER NUMBER	TEMPERATURE RANGE	PACKAGE DESCRIPTION	COMPONENT PACKAGING
ACA2604RS29P8	-40 °C to +110 °C	RoHS-Compliant 28 Pin QFN 5 mm x 5 mm x 1 mm	Tape and Reel, 2500 pieces per Reel

**ANADIGICS, Inc.**

141 Mount Bethel Road
Warren, New Jersey 07059, U.S.A.

Tel: +1 (908) 668-5000

Fax: +1 (908) 668-5132

URL: <http://www.anadigics.com>

E-mail: Mktg@anadigics.com

IMPORTANT NOTICE

ANADIGICS, Inc. reserves the right to make changes to its products or to discontinue any product at any time without notice. The product specifications contained in Advanced Product Information sheets and Preliminary Data Sheets are subject to change prior to a product's formal introduction. Information in Data Sheets have been carefully checked and are assumed to be reliable; however, ANADIGICS assumes no responsibilities for inaccuracies. ANADIGICS strongly urges customers to verify that the information they are using is current before placing orders.

WARNING

ANADIGICS products are not intended for use in life support appliances, devices or systems. Use of an ANADIGICS product in any such application without written consent is prohibited.