

FEATURES

- Single Input, Six Output Design
- Wideband Operation to 1 GHz
- Nominal 5 dB Gain
- 4.0 dB Typical Noise Figure
- Single +3.3V or +5V Supply
- High Linearity, Low Distortion
- Current adjust pin for optimizing distortion performance
- Single-Ended 75 Ohm Inputs/Output
- Materials set consistent with RoHS Directives

APPLICATIONS

- All-Digital CATV Set-Top Boxes with Multiple Tuners
- Home Gateways, Multiple-Tuner TVs and Set-top boxes

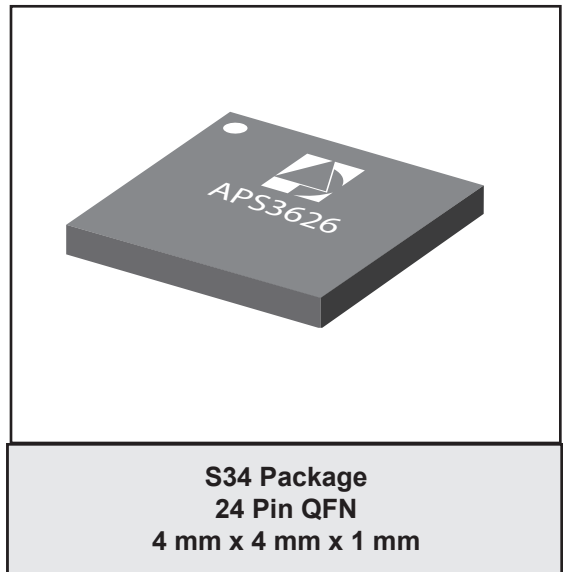

PRODUCT DESCRIPTION

This APS3626 active splitter from ANADIGICS accepts a broadband RF input from 51 MHz to 1002 MHz and splits the signal to provide six broadband RF outputs with minimal degradation of quality. The single-package surface mount device amplifies the input using highly linear, low noise amplification stages, and couples the amplified signal to six separate output paths that can each drive digital video tuners. The overall linearity of each path is maintained across the entire operating frequency range, ensuring low distortion effects on each output signal.

Requiring a single voltage supply of either +3.3V or +5 V, the active splitter is manufactured using ANADIGICS' highly reliable GaAs MESFET process. The small surface mount QFN packaging makes this device ideal for use in today's set-top boxes, televisions and video tuner cards requiring multiple-tuner solutions.

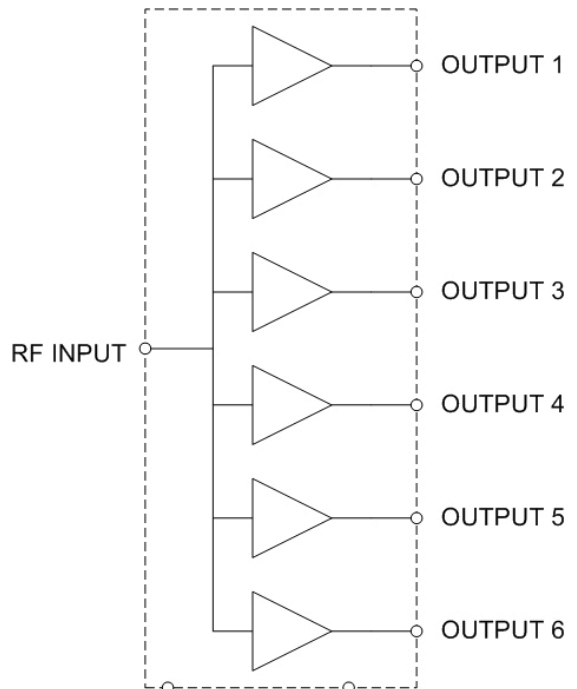

Figure 1: Functional Block Diagram

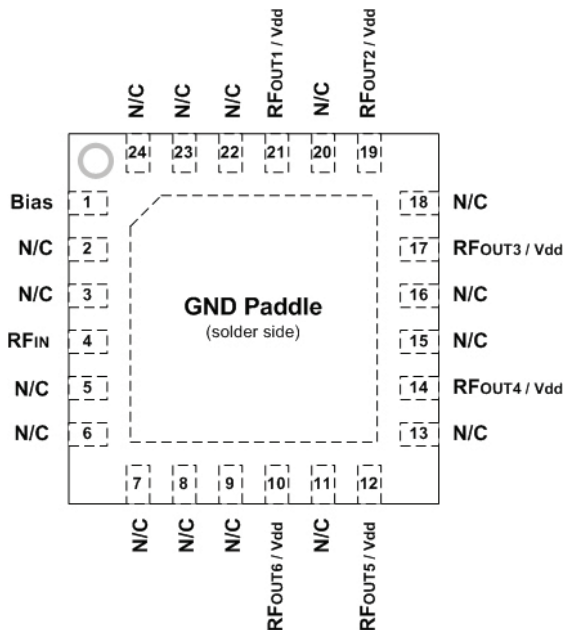

Figure 2: Pinout Diagram (X-ray Top View)

Table 1: Pin Description

PIN	NAME	DESCRIPTION	PIN	NAME	DESCRIPTION
1	Bias	Bias	24	N/C	No Connection
2	N/C	No Connection	23	N/C	No Connection
3	N/C	No Connection	22	N/C	No Connection
4	RF _{IN}	RF Input	21	RF _{OUT1}	RF Output 1/V _{DD}
5	N/C	No Connection	20	N/C	No Connection
6	N/C	No Connection	19	RF _{OUT2}	RF Output 2/V _{DD}
7	N/C	No Connection	18	N/C	No Connection
8	N/C	No Connection	17	RF _{OUT3}	RF Output 3/V _{DD}
9	N/C	No Connection	16	N/C	No Connection
10	RF _{OUT6}	RF Output 6/V _{DD}	15	N/C	No Connection
11	N/C	No Connection	14	RF _{OUT4}	RF Output 4/V _{DD}
12	RF _{OUT5}	RF Output 5/V _{DD}	13	N/C	No Connection

ELECTRICAL CHARACTERISTICS

Table 2: Absolute Minimum and Maximum Ratings

PARAMETER	MIN	MAX	UNIT	COMMENTS
Supply Voltage (V_{CC})	0	+8	V	
RF Input Power	-	+40	dBmV	per channel 132 channel loading
ESD Rating	500 1000	- -	V	Human Body Model, Class 1B Charged Device Model, Class 3
MSL Level	MSL-1	-	-	

Stresses in excess of the absolute ratings may cause permanent damage. Functional operation is not implied under these conditions. Exposure to absolute ratings for extended periods of time may adversely affect reliability.

Table 3: Operating Ranges

PARAMETER	MIN	TYP	MAX	UNIT	COMMENTS
Operating Frequency (f)	50	-	1002	MHz	
Supply Voltage (V_{CC})	+3.0	-	5.25	V	Supplied via output pins
RF Input Power (P_{IN})	-15	-	+15	dBmV	per channel
Current Adjust Pin (I_{ADJ})	0	-	+0.5	V	
Case Temperature (T_C)	-5	-	+85	°C	no damage to device operating over -30 to +95 °C range

The device may be operated safely over these conditions; however, parametric performance is guaranteed only over the conditions defined in the electrical specifications.

Table 4: Electrical Specifications
 (T_{AMB} = +25 °C, V_{CC} = +3.3 V, I_{CC} = 140 mA, 75 Ω system)

PARAMETER	MIN	TYP	MAX	UNIT	COMMENTS
Gain at 50 MHz	4.5	5	-	dB	
Noise Figure	-	4	-	dB	
CTB ⁽¹⁾	-	-70	-	dBc	
CSO ⁽¹⁾	-	-57	-	dBc	
XMOD ⁽¹⁾	-	-67	-	dBc	
RF Isolation Input-Output Output-Output	- - -	25 25	- - -	dB	
Input Return Loss	-	-15	-	dB	
Power Consumption	-	462	-	mW	

Notes:

(1) 132 channels, +15 dBmV input per channel, 0 dB tilt.

APPLICATION INFORMATION

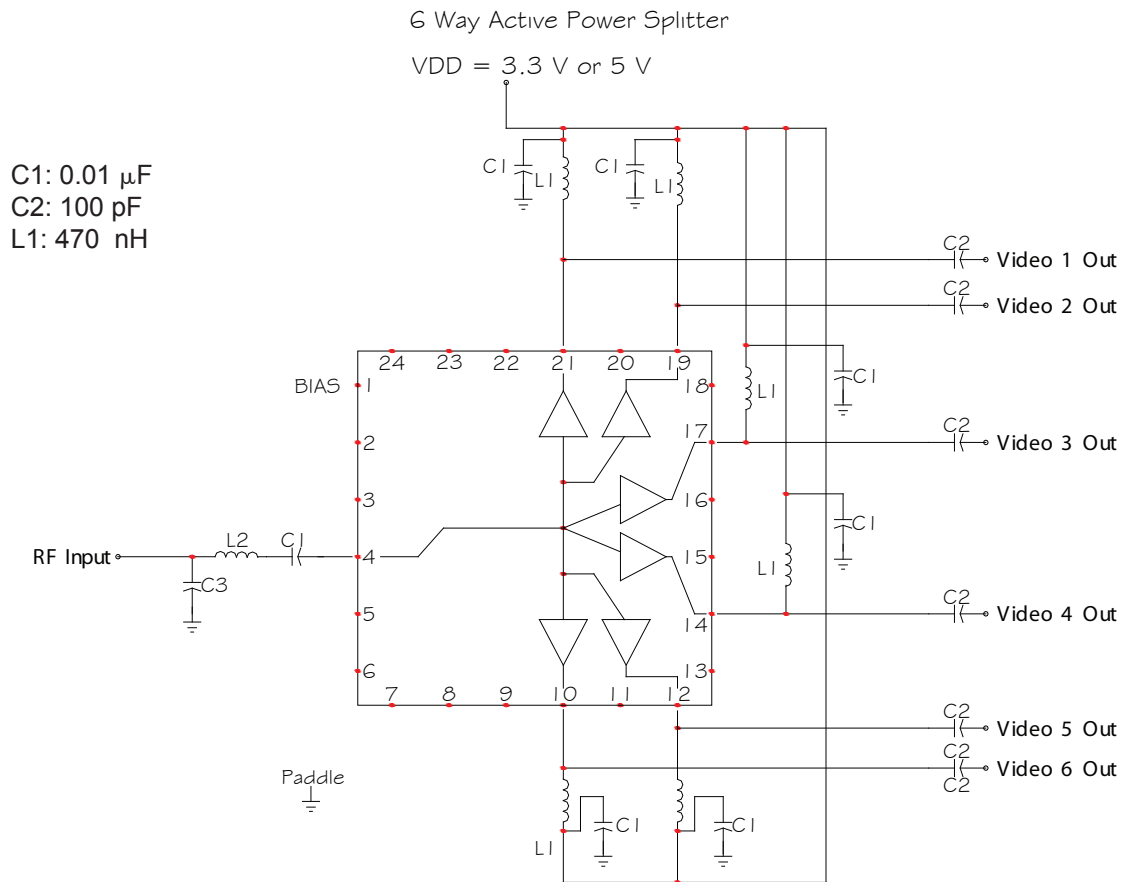
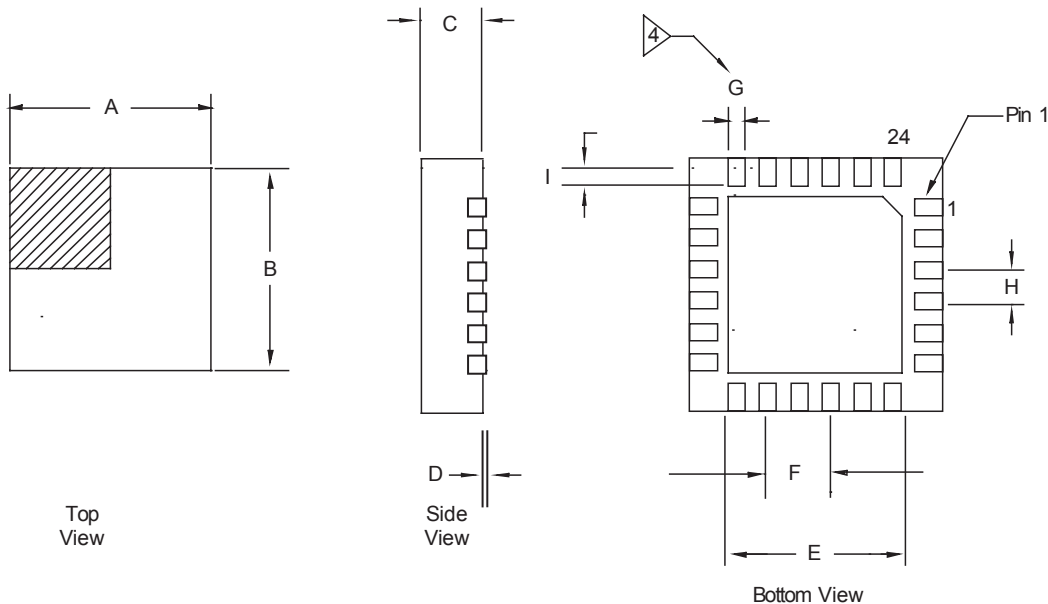

Figure 3: 8-Way Active Splitter Digital Application Circuit

Note:

Application circuits are available for other supply voltages. Contact ANADIGICS broadband engineering for more detail.

PACKAGE OUTLINE



DIMENSION	MILLIMETERS		
	MIN	TYP	MAX
A	3.90	4.00	4.10
B	3.90	4.00	4.10
C	0.80	0.90	1.00
D	0.00	0.02	0.05
E	2.50	2.65	2.80
F	1.00 BSC.		
G	0.180	0.250	0.300
H	0.50 BSC.		
I	0.35	0.40	0.45

1. All dimensions are in millimeters, angles in degrees.
2. The terminal #1 identifier and pad numbering convention shall conform to JESD 95-1 SPP-012
3. Lead coplanarity: 0.05 max
4. Dimension applies to metalized pad and is measured between 0.25 and 0.30 MM from pad tip.

Figure 4: S34 Package Outline - 24 Pin 4 mm x 4 mm x 1 mm QFN

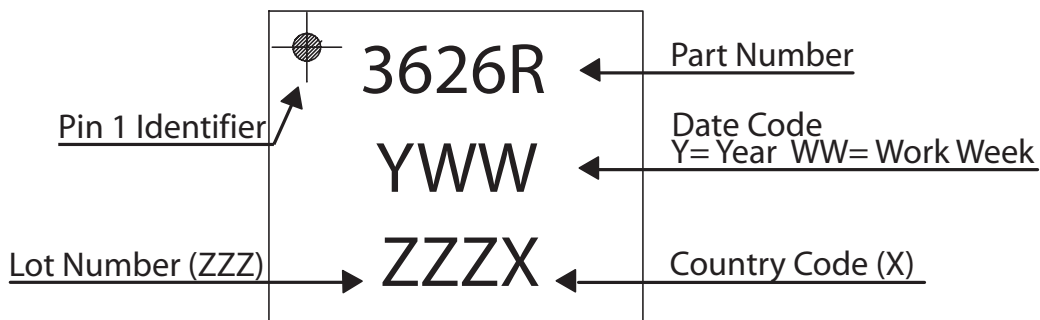

Figure 5: Branding Specification

ORDERING INFORMATION

ORDER NUMBER	TEMPERATURE RANGE	PACKAGE DESCRIPTION	COMPONENT PACKAGING
APS3626RS34Q1	-5 °C to +85 °C	24 Pin 4 mm x 4 mm x 1 mm LPCC (QFN)	2,500 piece Tape & Reel



ANADIGICS, Inc.

141 Mount Bethel Road
Warren, New Jersey 07059, U.S.A.

Tel: +1 (908) 668-5000

Fax: +1 (908) 668-5132

URL: <http://www.anadigics.com>

E-mail: Mktg@anadigics.com

IMPORTANT NOTICE

ANADIGICS, Inc. reserves the right to make changes to its products or to discontinue any product at any time without notice. The product specifications contained in Advanced Product Information sheets and Preliminary Data Sheets are subject to change prior to a product's formal introduction. Information in Data Sheets have been carefully checked and are assumed to be reliable; however, ANADIGICS assumes no responsibilities for inaccuracies. ANADIGICS strongly urges customers to verify that the information they are using is current before placing orders.

WARNING

ANADIGICS products are not intended for use in life support appliances, devices or systems. Use of an ANADIGICS product in any such application without written consent is prohibited.