



## APS3623

1 GHz Three-way Active Power Splitter  
Optimized for MoCA-Enabled  
Subscriber Equipment  
**PRELIMINARY DATA SHEET - Rev 1.3**

### FEATURES

- Single Input, Triple Output Design
- Gain profile compensates for inband MoCA line filter attenuation
- Wideband Operation to 1 GHz
- Supports both Analog TV and Digital TV Lineups
- Nominal 5 dB Gain
- 4.5 dB Typical Noise Figure
- Single +3.3 V or +5 V Supply
- Current adjust pin for optimizing distortion performance
- High Linearity, Low Distortion
- Single-Ended 75 Ohm Inputs/Outputs
- Materials set consistent with RoHS directives

### APPLICATIONS

- Analog/Digital and All-Digital CATV Set-Top Boxes with Multiple Tuners and Multimedia over Coax Alliance (MoCA) Functionality
- Multiple-Tuner TVs, TV Tuner Cards and Broadband Media Centers

### PRODUCT DESCRIPTION

This APS3623 active splitter from ANADIGICS accepts a broadband RF input from 50 MHz to 1 GHz and splits the signal to provide three broadband RF outputs with minimal degradation of quality. The single-package surface mount device amplifies the input using highly linear, low noise amplification stages, and couples the amplified signal to three separate output paths that each can drive either analog video, digital video or digital data tuners. The APS3623 offers a special



frequency/gain profile, which compensates for inband signal attenuation caused by MoCA line filters.

Requiring a single voltage supply of +3.3 V or +5 V, the active splitter is manufactured using ANADIGICS' highly reliable GaAs MESFET process. The small surface mount QFN packaging makes this device ideal for use in today's set-top boxes, televisions and video tuner cards requiring multiple-tuner solutions.

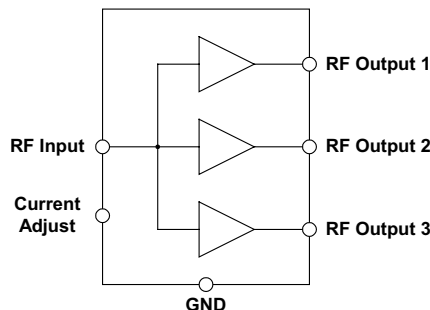

**Figure 1: Functional Block Diagram**

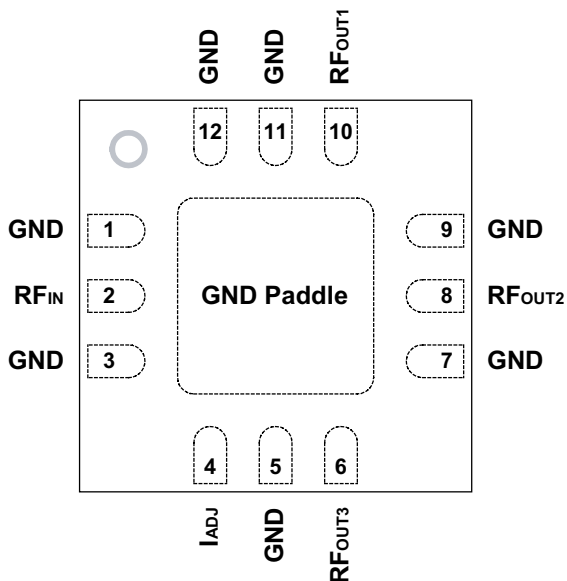

Figure 2: Pinout (X-ray Top View)

Table 1: Pin Description

PIN	NAME	DESCRIPTION
1	GND <sup>(1)</sup>	Ground
2	RF <sub>IN</sub>	RF Input
3	GND <sup>(1)</sup>	Ground
4	I <sub>ADJ</sub>	Current Adjust
5	GND <sup>(1)</sup>	Ground
6	RF <sub>OUT3</sub>	RF Output 3
7	GND <sup>(1)</sup>	Ground
8	RF <sub>OUT2</sub>	RF Output 2
9	GND <sup>(1)</sup>	Ground
10	RF <sub>OUT1</sub>	RF Output 1
11	GND <sup>(1)</sup>	Ground
12	GND <sup>(1)</sup>	Ground

Note:

(1) The only circuit ground required is the GND paddle. Pins 1, 3, 5, 7, 9, 11, and 12 are not connected internally and can be left floating, if preferred.

**ELECTRICAL CHARACTERISTICS**

**Table 2: Absolute Minimum and Maximum Ratings**

PARAMETER	MIN	MAX	UNIT	COMMENTS
Supply Voltage (V <sub>CC</sub> )	0	+8	V	
RF Input Power	-	+40	dBmV	per channel 132 channel loading
ESD Rating	500 1000	- -	V	Human Body Model, Class 1B Charged Device Model, Class 3
MSL Level	MSL-2	-	-	

Stresses in excess of the absolute ratings may cause permanent damage. Functional operation is not implied under these conditions. Exposure to absolute ratings for extended periods of time may adversely affect reliability.

**Table 3: Operating Ranges**

PARAMETER	MIN	TYP	MAX	UNIT	COMMENTS
Operating Frequency (f)	50	-	1002	MHz	
Supply Voltage (V <sub>CC</sub> )	2.95	-	5.25	V	
RF Input Power (P <sub>IN</sub> )	-	-	+18	dBmV	per channel
Case Temperature (T <sub>C</sub> )	-5	-	+85	°C	no damage to device operating over -30 to +95 °C range

The device may be operated safely over these conditions; however, parametric performance is guaranteed only over the conditions defined in the electrical specifications.

**Table 4: Electrical Specifications**  
 (T<sub>AMB</sub> = +25 °C, V<sub>CC</sub> = +5 V, I<sub>CC</sub> = 140 mA, 75 Ω system, ref. Figure 2)

PARAMETER	MIN	TYP	MAX	UNIT	COMMENTS
Gain at 55 MHz	3.9	-	-	dB	
Gain at 100 MHz	-	5.0	-	dB	
Gain at 1002 MHz	5.2	6.0	-	dB	
Noise Figure	-	4.5	-	dB	
CTB <sup>(1)</sup>	-	-77	-66	dBc	
CSO <sup>(1)</sup>	-	-65	-64	dBc	
XMOD <sup>(1)</sup>	-	-72	-	dBc	
RF Isolation Input-Output Output-Output	- - -	21 22	- -	dB	
Input Return Loss	-	-15	-	dB	
Current Consumption (I <sub>CC</sub> )	110	140	170	mA	

Notes:

(1) 132 channels, +15 dBmV input per channel.

**Table 5: Electrical Specifications**  
 (T<sub>AMB</sub> = +25 °C, V<sub>CC</sub> = +3.3 V, I<sub>CC</sub> = 86 mA, 75 Ω system, ref. Figure 3)

PARAMETER	MIN	TYP	MAX	UNIT	COMMENTS
Gain at 55 MHz	-	4.9	-	dB	
Gain at 100 MHz	-	5.0	-	dB	
Gain at 1002 MHz		6.0	-	dB	
Noise Figure	-	4.5	-	dB	
CTB <sup>(1)</sup>	-	-74	-	dBc	
CSO <sup>(1)</sup>	-	-62	-	dBc	
XMOD <sup>(1)</sup>	-	-65	-	dBc	
RF Isolation Input-Output Output-Output	- - -	21 22	- -	dB	
Input Return Loss	-	-15	-	dB	
Current Consumption (I <sub>CC</sub> )	-	86	-	mA	

Notes:

(1) 132 channels, +15 dBmV input per channel.

+5 V Characterization Data:

Figure 5: Gain vs Frequency <sup>(1)</sup>

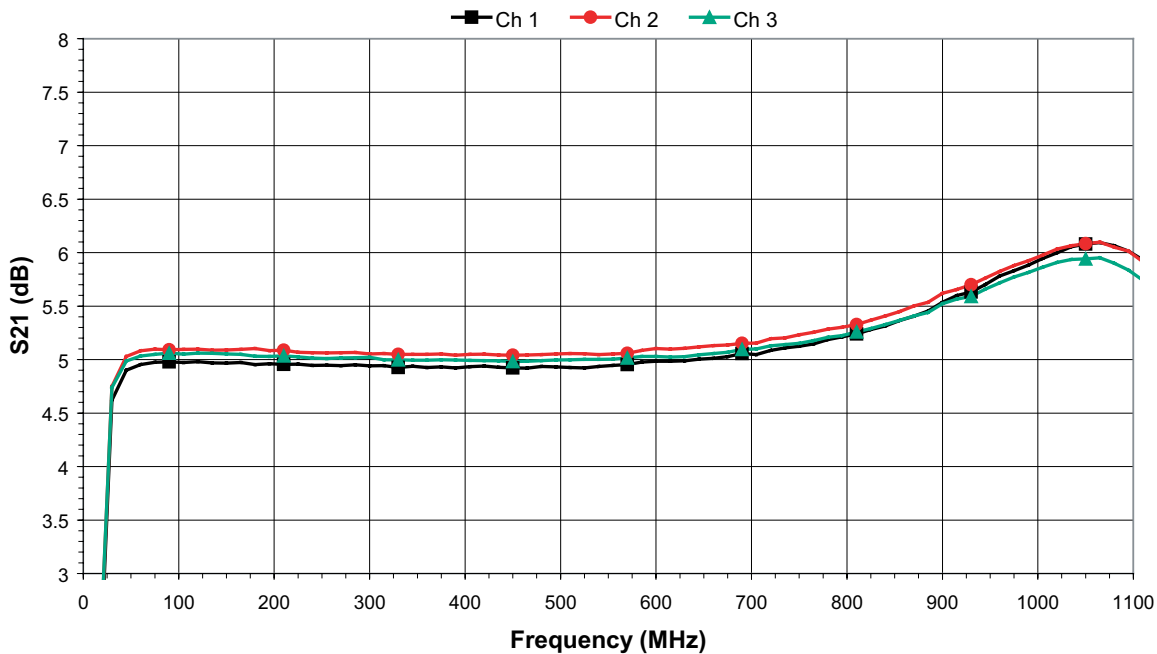

Figure 6: Input Return Loss vs Frequency <sup>(1)</sup>

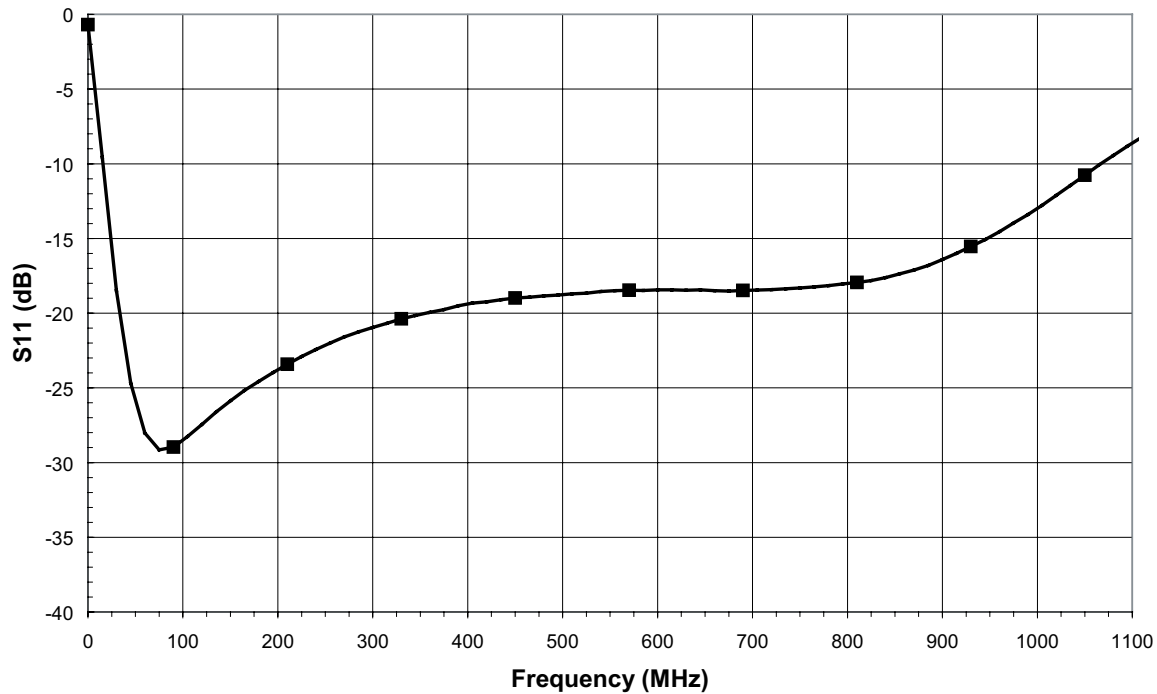

Figure 7: Output Return Loss vs Frequency <sup>(1)</sup>

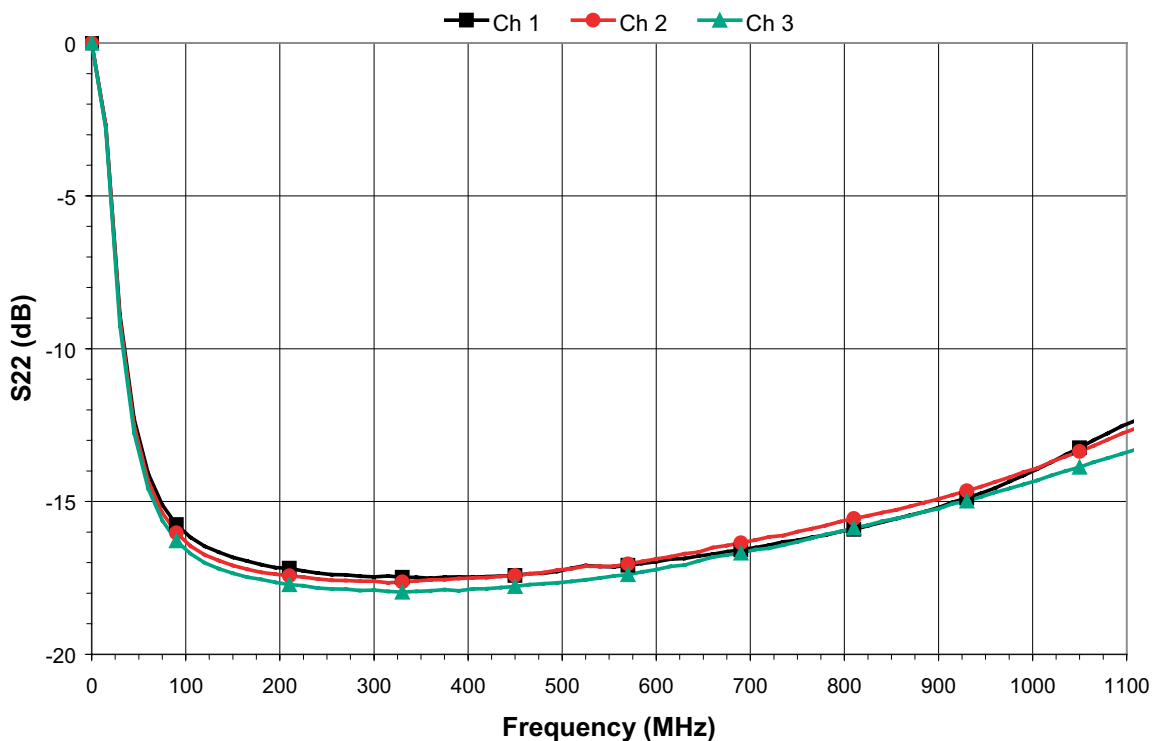

Figure 8: Reverse Isolation vs Frequency <sup>(1)</sup>

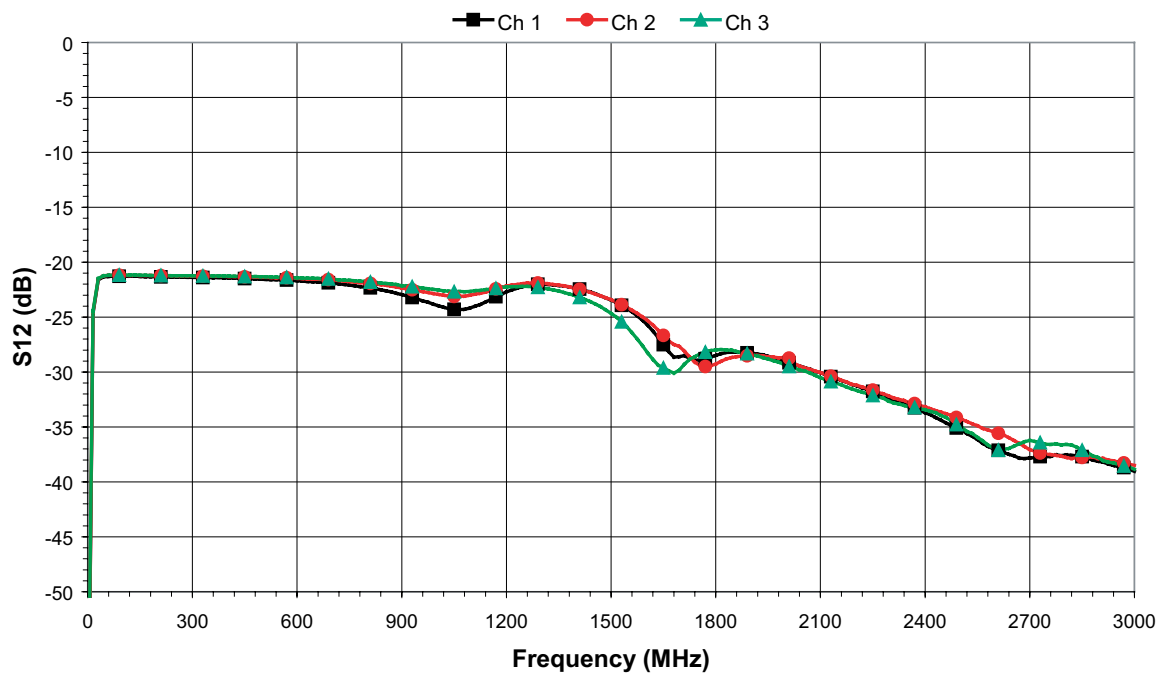

Figure 9: CSO vs Frequency <sup>(2)</sup>

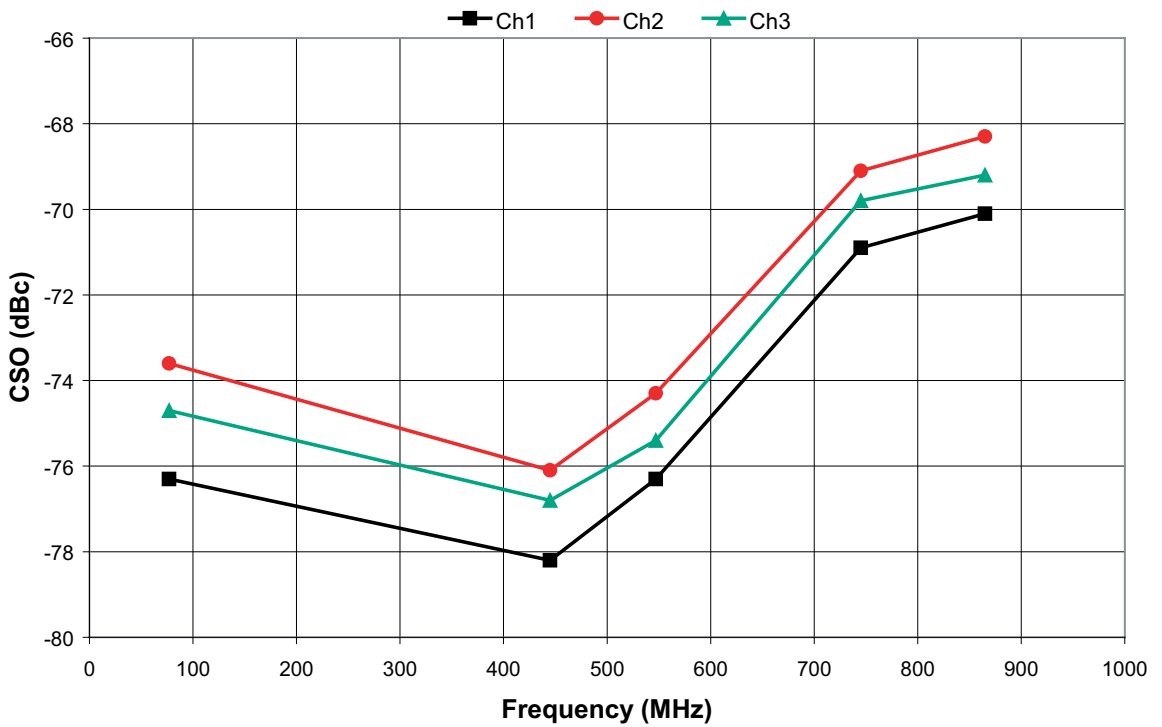

Figure 10: CTB vs Frequency <sup>(2)</sup>

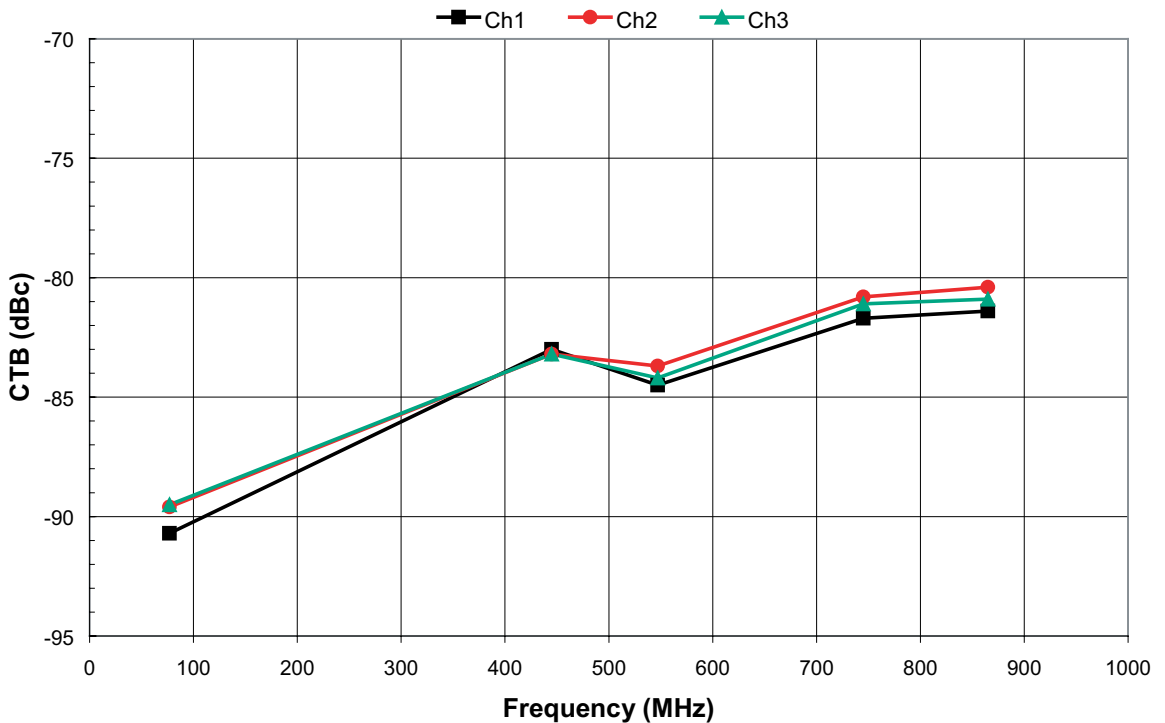

Figure 11: XMOD vs Frequency <sup>(2)</sup>

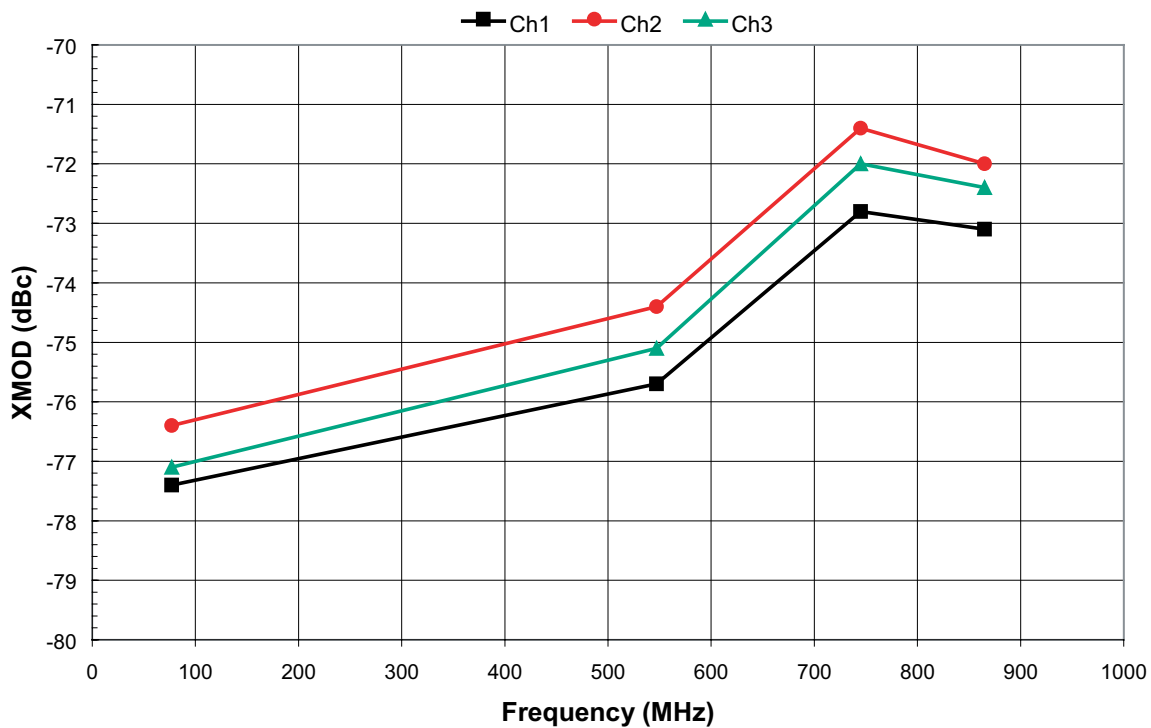

Figure 12: Noise Figure vs Frequency <sup>(2)</sup>

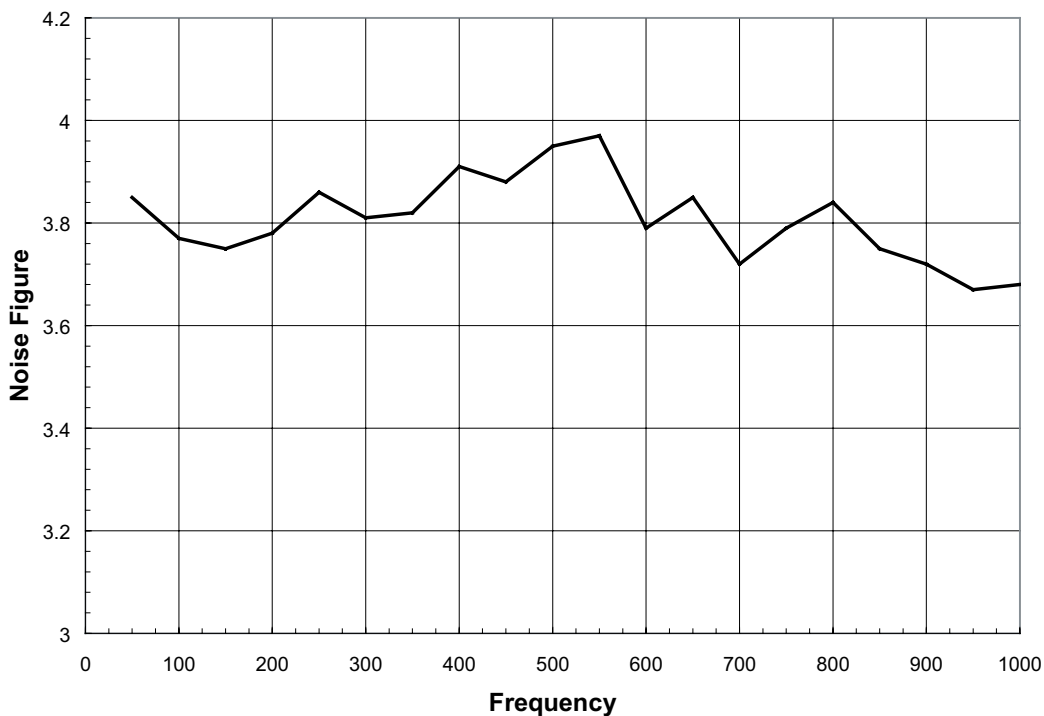
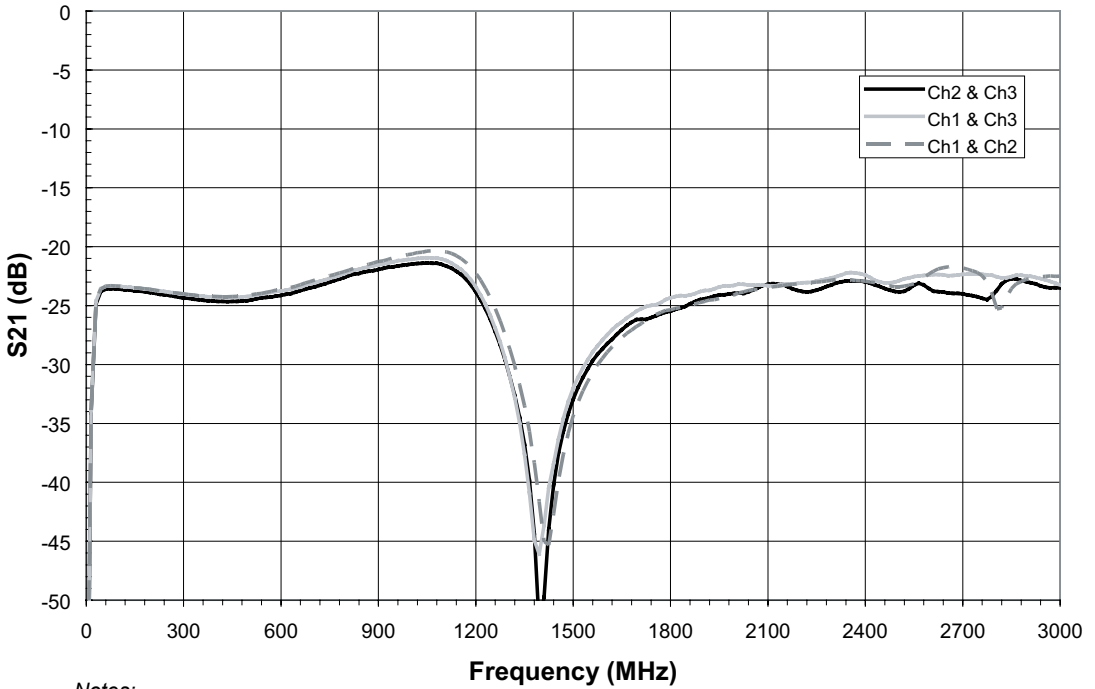

Figure 13: Output Port-to-Port Isolation vs Frequency <sup>(2)</sup>



Notes:

(1) Test Condition:  $T_{AMB} = +25^{\circ}\text{C}$ ,  $V_{CC} = +5\text{ V}$

(2) Test Condition: 132 Channels, 0 dB Tilt, +15 dBmV input power,  $T_{AMB} = +25^{\circ}\text{C}$ ,  $V_{CC} = +5\text{ V}$

**+3.3 V Characterization Data:**

Figure 14: CTB vs Frequency  
( $V_{DD} = +3.3\text{ V}$ , 5% Variation,  $I_{DD} = 86\text{ mA}$ )

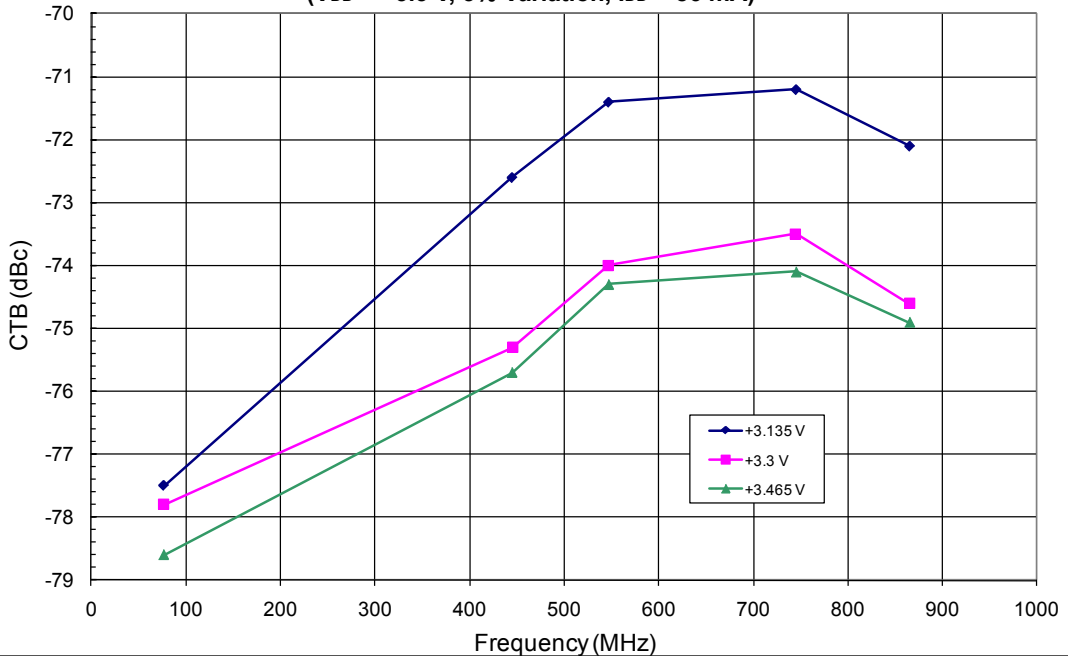

**Figure 15: CSO vs Frequency**  
 ( $V_{DD} = +3.3\text{ V}$ , 5% Variation,  $I_{DD} = 86\text{ mA}$ )

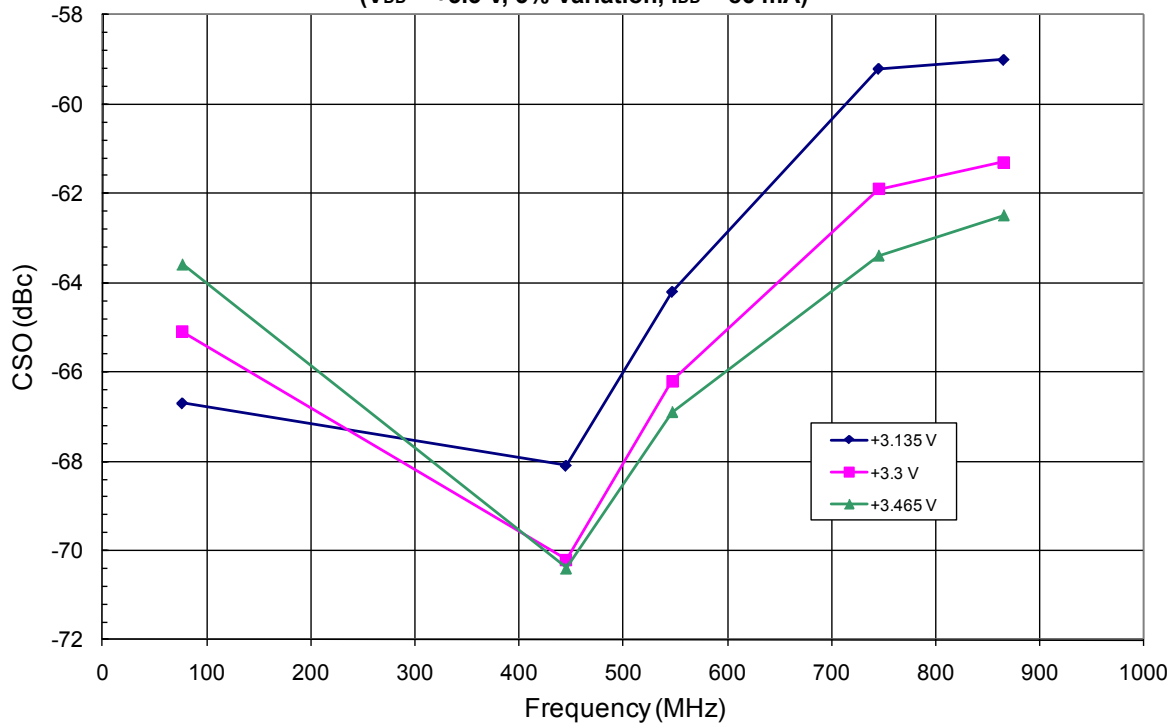

**Figure 16: XMOD vs Frequency**  
 ( $V_{DD} = +3.3\text{ V}$ , 5% Variation,  $I_{DD} = 86\text{ mA}$ )

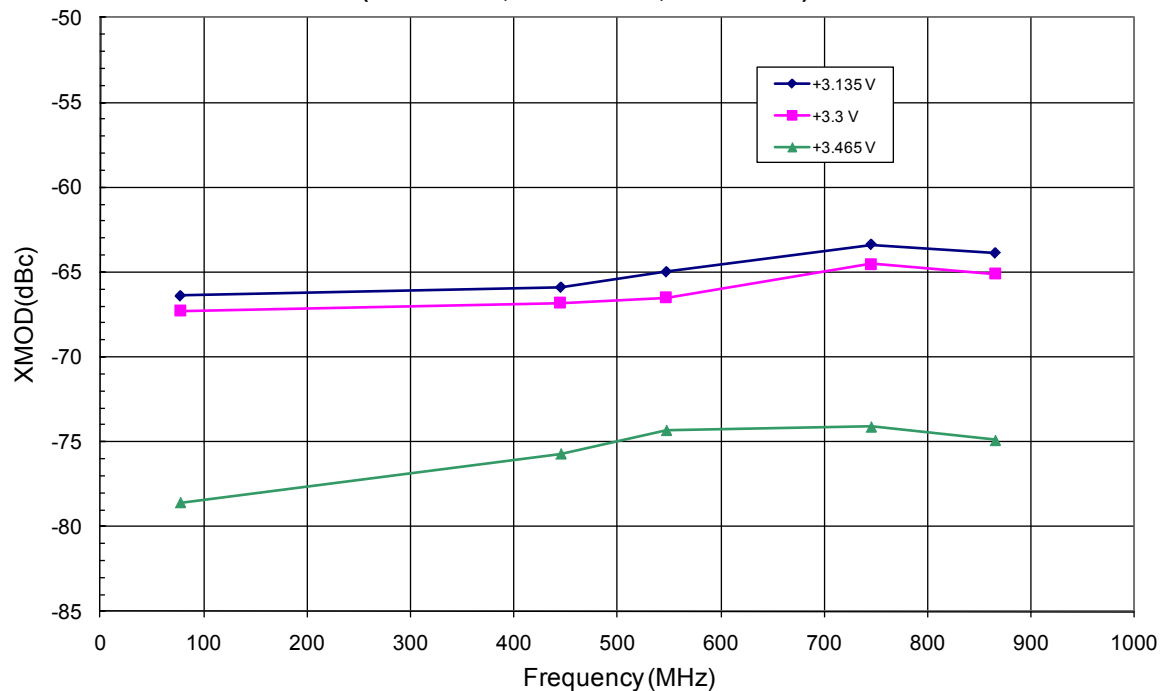

APPLICATION INFORMATION

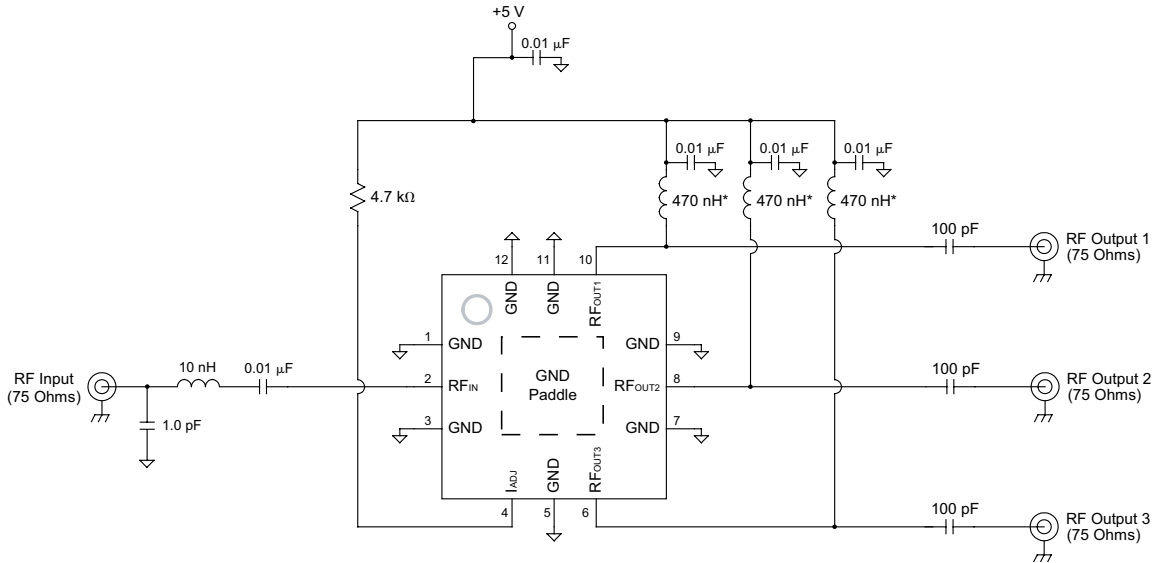

Figure 17: 5 V Application Circuit

Note:

(1) \*560 nH inductors may be substituted with a slight change in return loss.

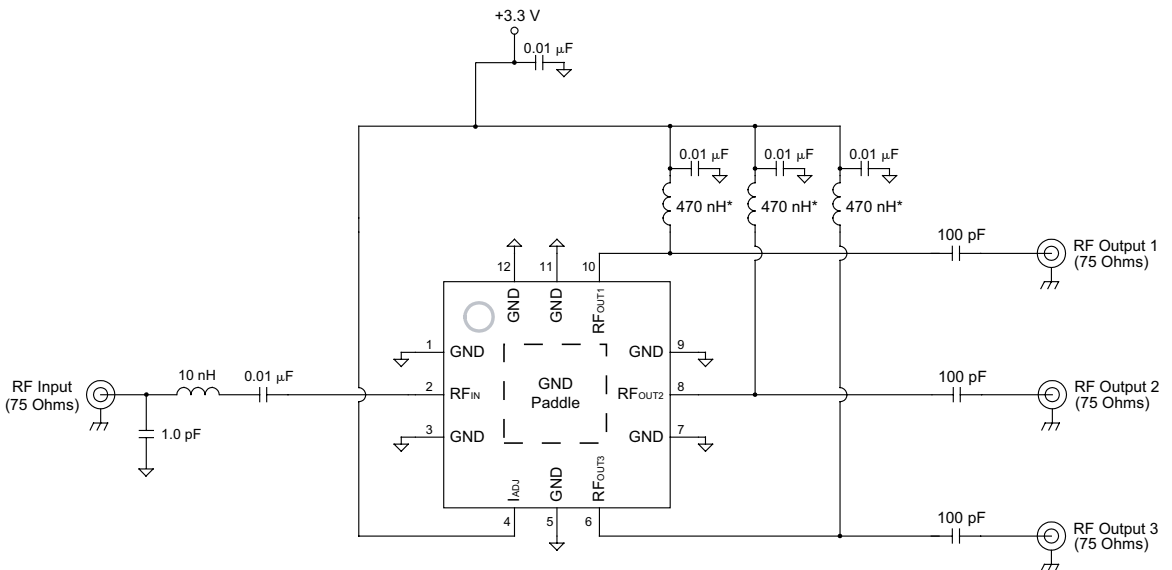
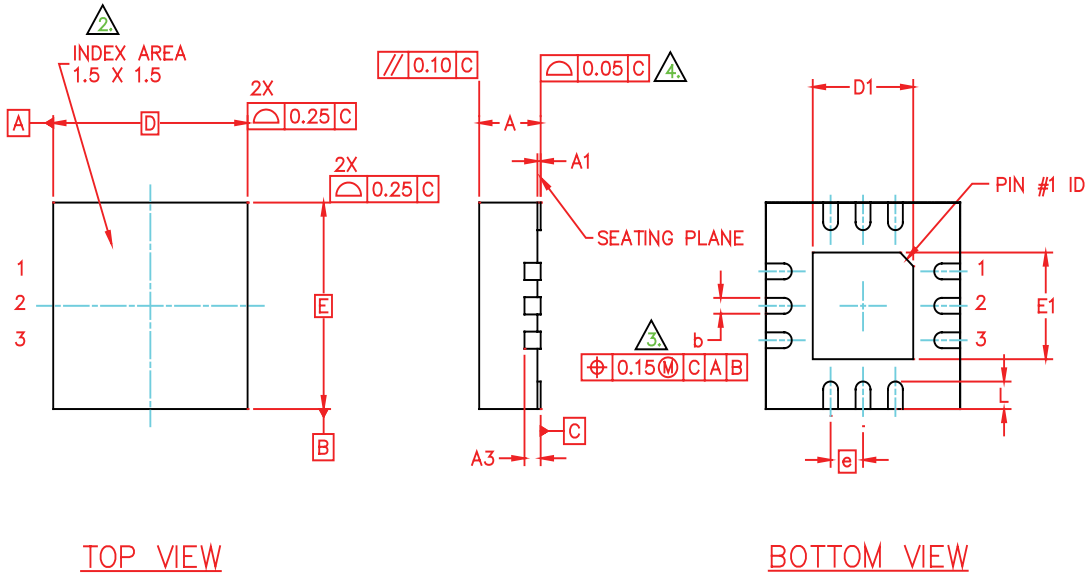

Figure 18: 3.3 V Application Circuit

Note:

(1) \*560 nH inductors may be substituted with a slight change in return loss.

PACKAGE OUTLINE



TOP VIEW

BOTTOM VIEW

NOTES :

- 1. ALL DIMENSIONS ARE IN MILLIMETERS.
- 2. TERMINAL #1 IDENTIFIER AND PAD NUMBERING CONVENTION SHALL CONFORM TO JEDEC 95-1 SPP-012.
- 3. DIMENSION b APPLIES TO METALLIZED TERMINAL AND IS MEASURED BETWEEN 0.25 AND 0.30mm FROM TERMINAL TIP.
- 4. BILATERAL COPLANARITY ZONE APPLIES TO THE EXPOSED PAD AS WELL AS THE TERMINALS.

S <sub>W</sub> L	DIMENSIONS—MM			N <sub>O</sub> T <sub>E</sub>	S <sub>W</sub> L	DIMENSIONS—INCHES			N <sub>O</sub> T <sub>E</sub>
	MIN.	NOM.	MAX.			MIN.	NOM.	MAX.	
A	0.80	0.90	1.00		A	0.031	0.035	0.039	
A1	0.00	0.02	0.05		A1	0.000	0.001	0.002	
A3		0.20	REF.		A3		0.008	REF.	
b	0.15	0.20	0.25		b	0.007	0.010	0.012	
D		3.00	BSC		D		0.118	BSC	
D1	1.40	1.55	1.65		D1	0.055	0.061	0.065	
E		3.00	BSC		E		0.118	BSC	
E1	1.40	1.55	1.65		E1	0.055	0.061	0.065	
e		0.50	BSC		e		0.020	BSC	
L	0.30	0.40	0.50		L	0.012	0.016	0.020	

Figure 19: S26 Package Outline - 12 Pin 3 mm x 3 mm x 1 mm QFN

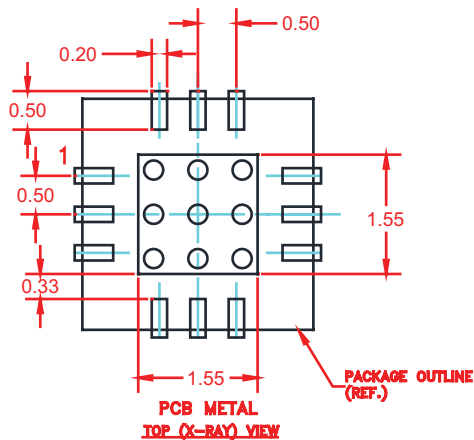

**NOTES:**

- (1) OUTLINE DRAWING REFERENCE: P8002533
- (2) UNLESS SPECIFIED DIMENSIONS ARE SYMMETRICAL ABOUT CENTER LINES SHOWN.
- (3) DIMENSIONS IN MILLIMETERS.
- (4) VIAS SHOWN IN PCB METAL VIEW ARE FOR REFERENCE ONLY. NUMBER & SIZE OF THERMAL VIAS REQUIRED DEPENDENT ON HEAT DISSIPATION REQUIREMENT AND THE PCB PROCESS CAPABILITY.
- (5) RECOMMENDED STENCIL THICKNESS: APPROX. 0.125mm (5 Mils)

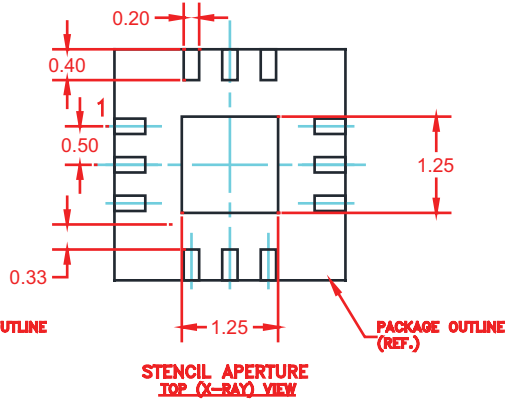
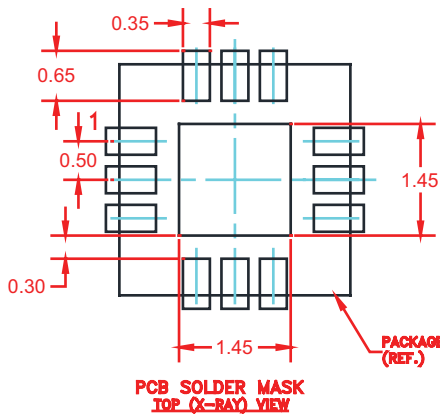

**Figure 20: 3 mm x 3 mm (12 Lead) QFN PCB Layout and Stencil**

**ORDERING INFORMATION**

ORDER NUMBER	TEMPERATURE RANGE	PACKAGE DESCRIPTION	COMPONENT PACKAGING
APS3623RS26Q1	-5 °C to +85 °C	12 Pin 3 mm x 3 mm x 1 mm QFN Package	Tape and Reel, 1000 pieces per Reel



**ANADIGICS, Inc.**

141 Mount Bethel Road  
Warren, New Jersey 07059, U.S.A.  
Tel: +1 (908) 668-5000  
Fax: +1 (908) 668-5132

URL: <http://www.anadigics.com>  
E-mail: [Mktg@anadigics.com](mailto:Mktg@anadigics.com)

**IMPORTANT NOTICE**

ANADIGICS, Inc. reserves the right to make changes to its products or to discontinue any product at any time without notice. The product specifications contained in Advanced Product Information sheets and Preliminary Data Sheets are subject to change prior to a product's formal introduction. Information in Data Sheets have been carefully checked and are assumed to be reliable; however, ANADIGICS assumes no responsibilities for inaccuracies. ANADIGICS strongly urges customers to verify that the information they are using is current before placing orders.

**WARNING**

ANADIGICS products are not intended for use in life support appliances, devices or systems. Use of an ANADIGICS product in any such application without written consent is prohibited.