

FEATURES

- Single Input, Double Output Design
- Gain profile compensates for inband MOCA line filter attenuation
- Wideband Operation to 870 MHz
- Supports both Analog TV and Digital TV Lineups
- Nominal 3 dB Gain
- 5 dB Typical Noise Figure
- Single +5 V Supply, with Operation Down to +3.3 V
- Current Adjust pin for optimizing distortion performance
- High Linearity, Low Distortion
- Single-Ended 75 Ohm Inputs/Outputs
- RoHS Compliant Package

APPLICATIONS

- Analog/Digital and All-Digital CATV Set-Top Boxes with Multiple Tuners and Multimedia Over Coax Alliance (MOCA) Functionality
- Multiple-Tuner TVs, TV Tuner Cards and Broadband Media Centers

PRODUCT DESCRIPTION

This APS3611 active splitter from ANADIGICS accepts a broadband RF input from 50 MHz to 870 MHz and splits the signal to provide two broadband RF outputs with minimal degradation of quality. The single-package surface mount device amplifies the input using highly linear, low noise amplification stages, and couples the amplified signal to two separate output paths that each can drive either analog video, digital video or digital

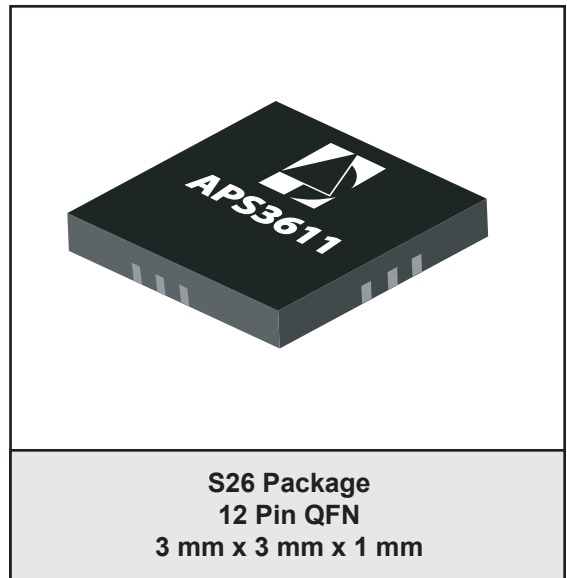

data tuners. The APS3611 offers a special frequency/gain profile, which compensates for inband signal attenuation caused by MOCA line filters.

Requiring a single voltage supply of +5 V, and operable down to +3.3 V, the active splitter is manufactured using ANADIGICS' highly reliable GaAs MESFET process. The small surface mount QFN packaging makes this device ideal for use in today's set-top boxes, televisions and video tuner cards requiring multiple-tuner solutions.

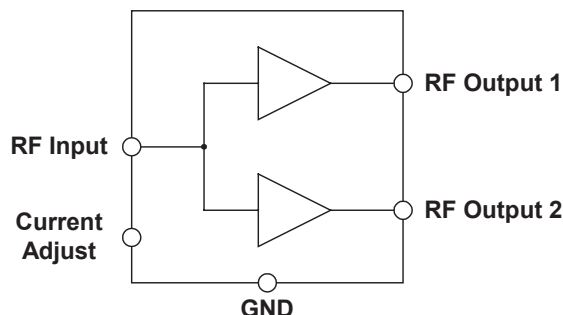

Figure 1: Functional Block Diagram

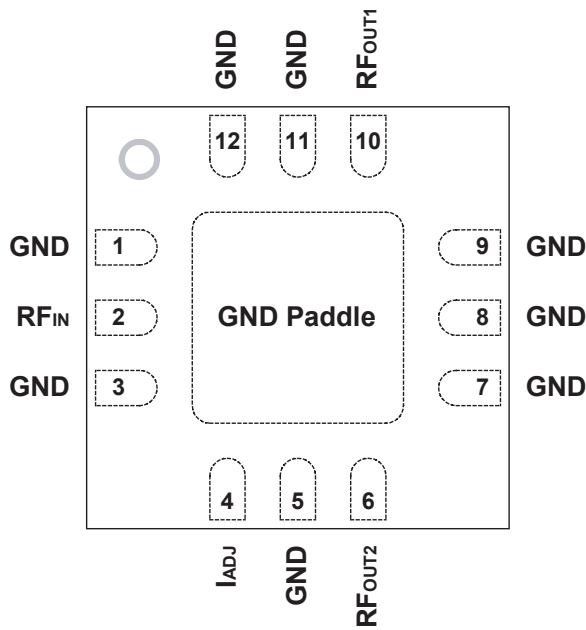

Figure 2: Pinout (X-ray Top View)

Table 1: Pin Description

PIN	NAME	DESCRIPTION
1	GND	Ground
2	RF _{IN}	RF Input
3	GND	Ground
4	I _{ADJ}	Current Adjust
5	GND	Ground
6	RF _{OUT2}	RF Output 2
7	GND	Ground
8	GND	Ground
9	GND	Ground
10	RF _{OUT1}	RF Output 1
11	GND	Ground
12	GND	Ground

ELECTRICAL CHARACTERISTICS

Table 2: Absolute Minimum and Maximum Ratings

PARAMETER	MIN	MAX	UNIT	COMMENTS
Supply Voltage (V_{CC})	0	+8	V	
RF Input Power	-	+25	dBmV	per channel
MSL Level	MSL-1	-	-	

Stresses in excess of the absolute ratings may cause permanent damage. Functional operation is not implied under these conditions. Exposure to absolute ratings for extended periods of time may adversely affect reliability.

Table 3: Operating Ranges

PARAMETER	MIN	TYP	MAX	UNIT	COMMENTS
Operating Frequency (f)	50	-	870	MHz	
Supply Voltage (V_{CC})	-	+5	-	V	
RF Input Power (P_{IN})	-	-	+18	dBmV	per channel
Case Temperature (T_C)	-5	-	+85	°C	no damage to device operating over -30 to +95 °C range

The device may be operated safely over these conditions; however, parametric performance is guaranteed only over the conditions defined in the electrical specifications.

Table 4: Electrical Specifications
 (T_{AMB} = +25 °C, V_{CC} = +5 V, I_{CC} = 120 mA, 75 Ω system, ref. Figure 12)

PARAMETER	MIN	TYP	MAX	UNIT	COMMENTS
Gain at 100 MHz	-	3.5	-	dB	
Noise Figure	-	5	-	dB	
CTB ⁽¹⁾	-	-74	-	dBc	
CSO ⁽¹⁾	-	-67	-	dBc	
XMOD ⁽¹⁾	-	-66	-	dBc	
RF Isolation					
Input-Output	-	17	-	dB	
Output-Output	-	25	-	dB	
Input Return Loss	-	-15	-	dB	
Current Consumption (I _{CC})	-	120	-	mA	

Notes:

(1) 132 channels, +15 dBmV input per channel.

PERFORMANCE DATA

Figure 3: Gain (S21) vs. Frequency
(T_{AMB} = +25 °C, V_{CC} = +5 V)

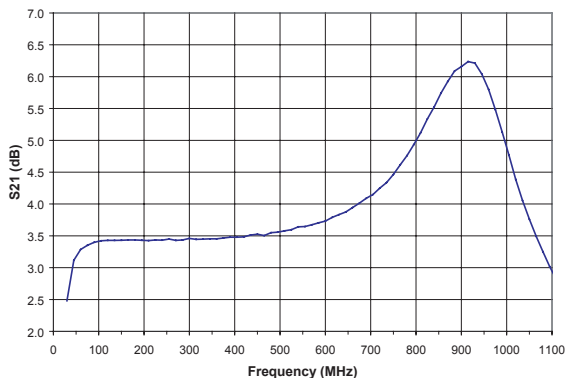

Figure 4: Input Return Loss (S11) vs. Frequency
(T_{AMB} = +25 °C, V_{CC} = +5 V)

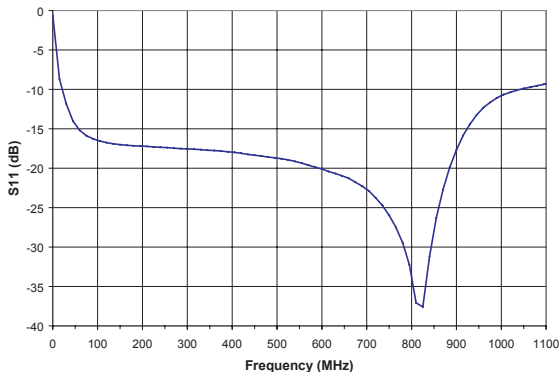

Figure 5: Reverse Isolation (S12) vs. Frequency
(T_{AMB} = +25 °C, V_{CC} = +5 V)

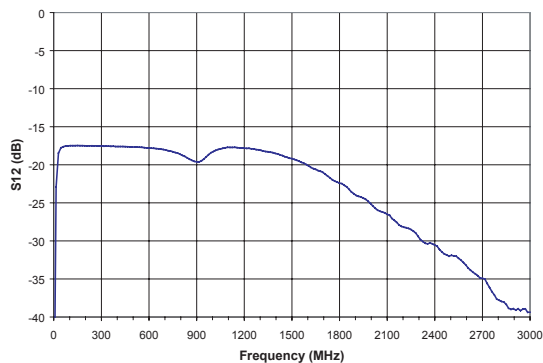

Figure 6: Output Return Loss (S22) vs. Frequency
(T_{AMB} = +25 °C, V_{CC} = +5 V)

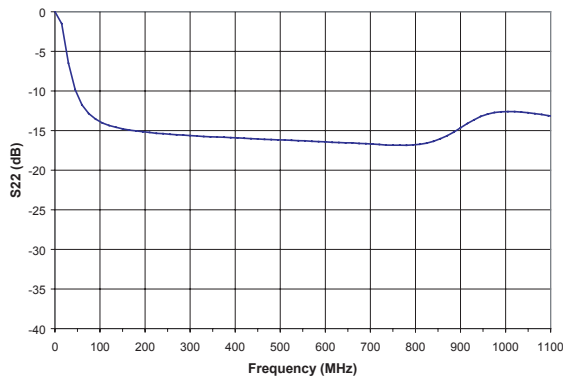

Figure 7: Noise Figure vs. Frequency
(T_{AMB} = +25 °C, V_{CC} = +5 V)

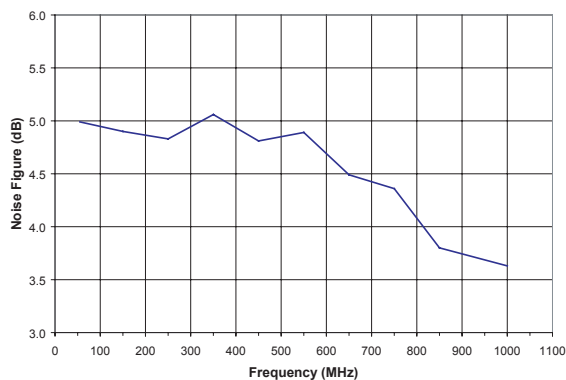

Figure 8: Port-to-Port Isolation vs. Frequency
(T_{AMB} = +25 °C, V_{CC} = +5 V)

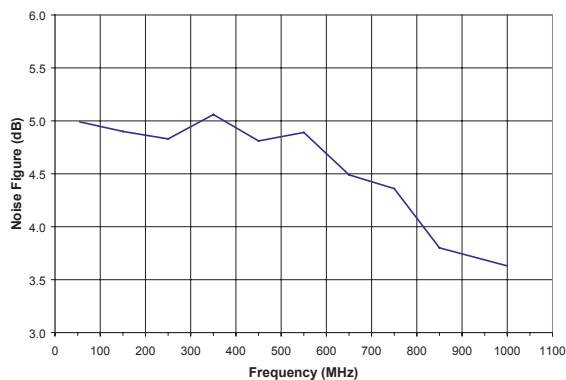

Figure 9: CTB vs. Frequency

($T_{AMB} = +25\text{ }^{\circ}\text{C}$, $V_{CC} = +5\text{ V}$, 132 channels, +15 dBmV input per channel)

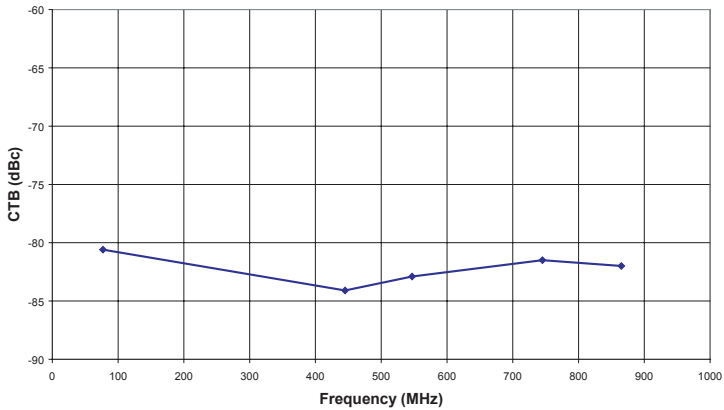

Figure 10: CSO vs. Frequency

($T_{AMB} = +25\text{ }^{\circ}\text{C}$, $V_{CC} = +5\text{ V}$, 132 channels, +15 dBmV input per channel)

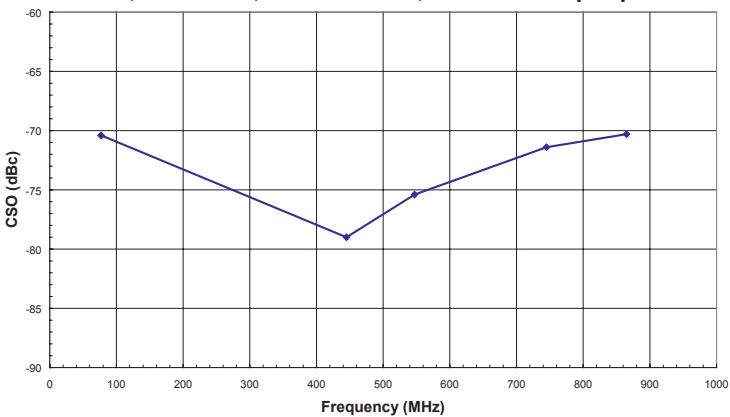
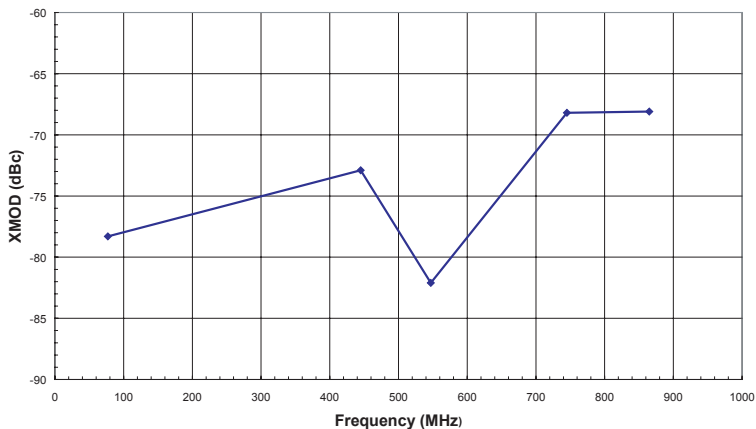

Figure 11: XMOD vs. Frequency

($T_{AMB} = +25\text{ }^{\circ}\text{C}$, $V_{CC} = +5\text{ V}$, 132 channels, +15 dBmV input per channel)



APPLICATION INFORMATION

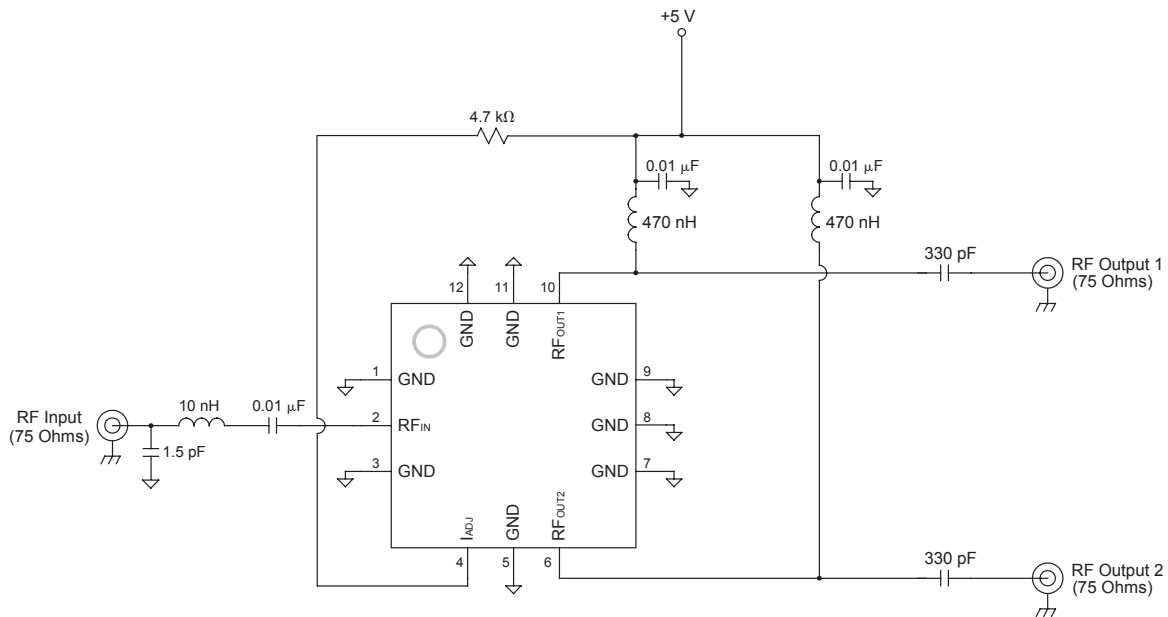
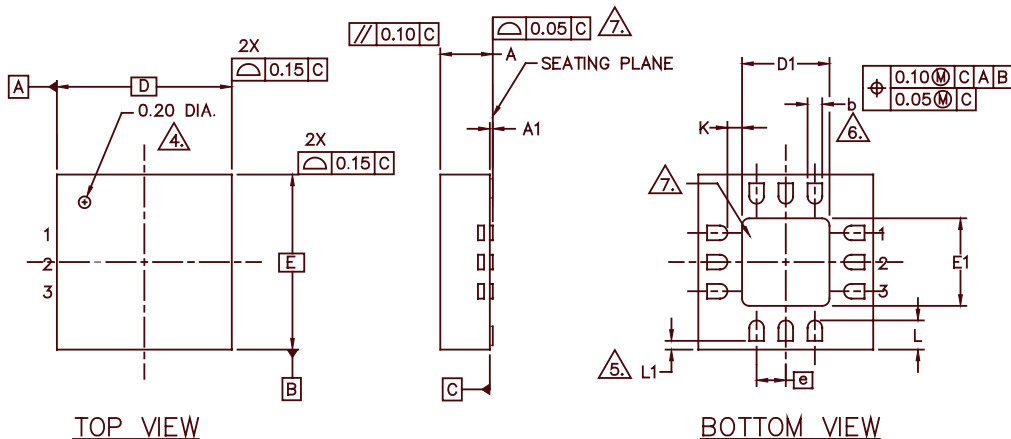
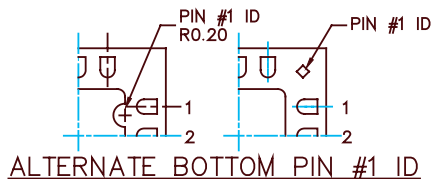

Figure 12: Application Circuit

PACKAGE OUTLINE



NOTES :

1. ALL DIMENSIONS ARE IN MILLIMETERS.
2. MAX. PACKAGE WARPAGE IS 0.05 mm.
3. MAXIMUM ALLOWABLE BURRS IS 0.076 mm IN ALL DIRECTIONS.
4. PIN #1 ID ON TOP WILL BE LASER MARKED.
5. A MAXIMUM 0.15mm PULL BACK (L1) MAYBE PRESENT. L MINUS L1 TO BE EQUAL TO OR GREATER THAN 0.30mm.
6. DIMENSION b APPLIES TO METALLIZED TERMINAL AND IS MEASURED BETWEEN 0.15 AND 0.30mm FROM TERMINAL TIP. IF THE TERMINAL HAS THE OPTIONAL RADIUS ON THE OTHER END OF THE TERMINAL, THE DIMENSION b SHOULD NOT BE MEASURED IN THAT RADIUS AREA.
7. BILATERAL COPLANARITY ZONE APPLIES TO THE EXPOSED HEAT SINK SLUG AS WELL AS THE TERMINALS.
8. REFERENCE JEDEC OUTLINE MO-220.

S V E	DIMENSIONS—MM		NOTE	S V E	DIMENSIONS—INCHES		NOTE
	MIN.	MAX.			MIN.	MAX.	
A	0.80	1.00		A	0.031	0.039	
A1	0.00	0.05		A1	0.000	0.001	
b	0.18	0.30		b	0.007	0.011	
D	3.00 BSC			D	0.118 BSC		
D1	1.30	1.70		D1	0.051	0.067	
E	3.00 BSC			E	0.118 BSC		
E1	1.30	1.70		E1	0.051	0.067	
e	0.50 BSC			e	0.019 BSC		
K	0.20 MIN.			K	0.007 MIN.		
L	0.35	0.55		L	0.014	0.022	
L1	0.15 MAX.			L1	0.006 MAX.		

Figure 13: S26 Package Outline - 12 Pin 3 mm x 3 mm x 1 mm QFN

NOTES

ORDERING INFORMATION

ORDER NUMBER	TEMPERATURE RANGE	PACKAGE DESCRIPTION	COMPONENT PACKAGING
APS3611RS26Q1	-5°C TO +85°C	RoHS Compliant 12 Pin 3 mm x 3 mm x 1 mm QFN Package	Tape and Reel, 1000 pieces per Reel



ANADIGICS, Inc.

141 Mount Bethel Road
Warren, New Jersey 07059, U.S.A.
Tel: +1 (908) 668-5000
Fax: +1 (908) 668-5132

URL: <http://www.anadigics.com>
E-mail: Mktg@anadigics.com

IMPORTANT NOTICE

ANADIGICS, Inc. reserves the right to make changes to its products or to discontinue any product at any time without notice. The product specifications contained in Advanced Product Information sheets and Preliminary Data Sheets are subject to change prior to a product's formal introduction. Information in Data Sheets have been carefully checked and are assumed to be reliable; however, ANADIGICS assumes no responsibilities for inaccuracies. ANADIGICS strongly urges customers to verify that the information they are using is current before placing orders.

WARNING

ANADIGICS products are not intended for use in life support appliances, devices or systems. Use of an ANADIGICS product in any such application without written consent is prohibited.