

**FEATURES**

- 28 dB Gain
- 40 MHz to 870 MHz Operating Range
- 0.5 dB Gain Flatness
- 24 V Supply
- Supply Current: 430 mA (Typ.)
- Very Low Distortion & Noise
- Robust Design and Insensitive to Voltage Transients
- GaAs Monolithic IC-Based
- Standard SOT-115J Package
- Rugged integrated ring wave surge protection
- Superior ESD protection, > 7 kV

**APPLICATIONS**

- Distribution Nodes and Line Extenders in CATV Systems

**PRODUCT DESCRIPTION**

The ACA3754 is a GaAs Hybrid Amplifier for CATV HFC distribution systems. It consists of two pairs of parallel amplifiers that are optimized for exceptionally low distortion and noise figure with input and output transient voltage protection. The ACA3754 is offered in a standard SOT-115J package.

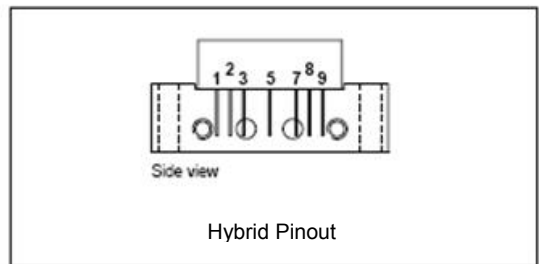
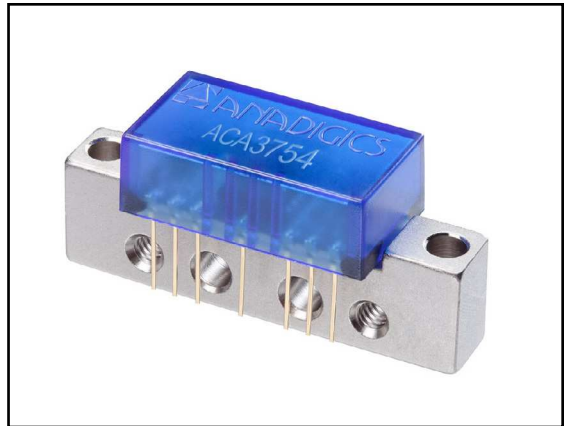

**Figure 2: Hybrid Pinout**

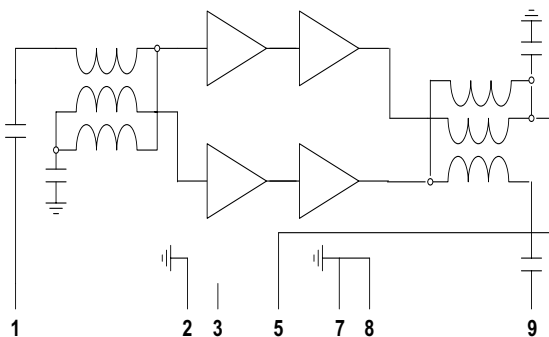

**Figure 1: Simplified Hybrid Internal Arrangement**

**Table 1: SOT-115J Pinning**

PIN	Description
1	RF Input
2	GND
3	GND or No Connection
5	24 V
7, 8	GND
9	RF Output

**Table 2: Absolute Minimum and Maximum Ratings**

	Symbol	Min	Typ	Max	Unit	Conditions
Supply Voltage	V <sub>DD</sub>	-	+24	+28	V <sub>DC</sub>	
RF Power at inputs	-	-	-	+70	dBmV	single tone
Operating mounting Base temperature	T <sub>MB</sub>	-20	-	+100	°C	
Storage Temperature	T <sub>STG</sub>	-40		+100	°C	

**Table 3: Operating Ranges**

	Symbol	Min	Typ	Max	Unit	Conditions
RF Frequency	-	40	-	870	MHz	

**Table 4: Electrical Characteristics**  
 (Test condition: 40 to 870 MHz, T<sub>MB</sub> = 30 °C, 75 Ω loading)

	Symbol	Min	Typ	Max	Unit	Conditions
Power Gain	G <sub>P</sub>	27.0	27.8	29.0	dB	f = 870 MHz
Slope cable equivalent	SL	-	1.5	-	dB	47 MHz to 870 MHz
Gain Flatness	FL	-	0.5	0.7	dB	47 MHz to 870 MHz (peak to valley)
Input Return Loss	S <sub>11</sub>	-	-	-20 -18 -16	dB	40 MHz to 380 MHz 381 MHz to 780 MHz 781 MHz to 870 MHz
Output Return Loss	S <sub>22</sub>	-	-	-20 -18 -16	dB	40 MHz to 380 MHz 381 MHz to 780 MHz 781 MHz to 870 MHz
CTB	-	-	-65 -65	-60 -	dBc	See Note 1 See Note 2
CSO	-	-	-65 -65	-60 -	dBc	See Note 1 See Note 2
Noise Figure	-	-	3.5	5.0	dB	
Supply Current	-	-	430	460	mA	

**Notes:**

(1) 79 flat NTSC analog channels @ +48 dBmV/ch output to 550 MHz, plus 53 flat analog channels @ +42 dBmV/ch above 550 MHz.

(2) 79 flat NTSC channels at +53 dBmV per channel output.

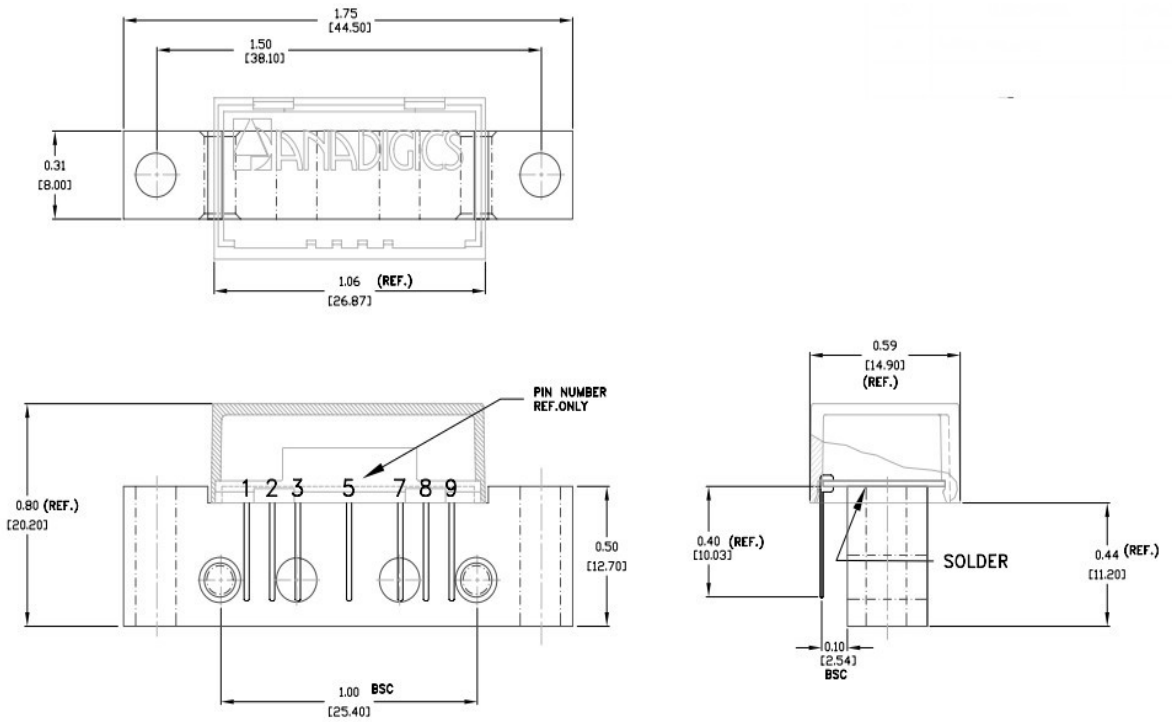

Figure 3: Hybrid Line Amp Physical Outline



Figure 4: Branding Specification

**ORDERING INFORMATION**

ORDER NUMBER	TEMPERATURE RANGE	PACKAGE DESCRIPTION	COMPONENT PACKAGING
ACA3754V0	-20 °C to +100 °C	SOT-115J Hybrid Amplifier	100 Piece Box
ACA3754P9	-20 °C to +100 °C	SOT-115J Hybrid Amplifier	Special handling

**ANADIGICS, Inc.**

141 Mount Bethel Road  
Warren, New Jersey 07059, U.S.A.

Tel: +1 (908) 668-5000

Fax: +1 (908) 668-5132

URL: <http://www.anadigics.com>

**IMPORTANT NOTICE**

ANADIGICS, Inc. reserves the right to make changes to its products or to discontinue any product at any time without notice. The product specifications contained in Advanced Product Information sheets and Preliminary Data Sheets are subject to change prior to a product's formal introduction. Information in Data Sheets have been carefully checked and are assumed to be reliable; however, ANADIGICS assumes no responsibilities for inaccuracies. ANADIGICS strongly urges customers to verify that the information they are using is current before placing orders.

**WARNING**

ANADIGICS products are not intended for use in life support appliances, devices or systems. Use of an ANADIGICS product in any such application without written consent is prohibited.