

FEATURES

- InGaP HBT Technology
- 30 dB Gain
- 2.5 % EVM at +22 dBm (+3.3 V Supply)
- 4 % EVM at +23.5 dBm (+3.3 V Supply)
- 2.5 % EVM at +23.5 dBm (+4.2 V Supply)
- 4 % EVM at +25 dBm (+4.2 V Supply)
- High Efficiency
- Integrated 25 dB Attenuator
- Integrated Output Power Detector
- 50 Ω Matched RF Ports for Reduced External Component Count
- 4.5 mm x 4.5 mm x 1.4 mm Surface Mount Module, Materials Set Consistent with RoHS Directives

APPLICATIONS

- WiMAX Tranceivers That Support the IEEE 802.16d-2004, IEEE 802.16e-2005, and the ETSI EN301-021 Wireless standards

PRODUCT DESCRIPTION

The ANADIGICS AWM6423 WiMAX Power Amplifier is a high performance device that delivers exceptional linearity and efficiency at high levels of output power. Designed for portable or mobile applications in the 2.5-2.7 GHz band, it supports the IEEE 802.16e-2005 wireless standard, as well as the IEEE 802.16d-2004 and ETSI EN301-021 standards.

The device requires only a nominal +3.3 V supply and a low-current bias input. An increase in supply voltage

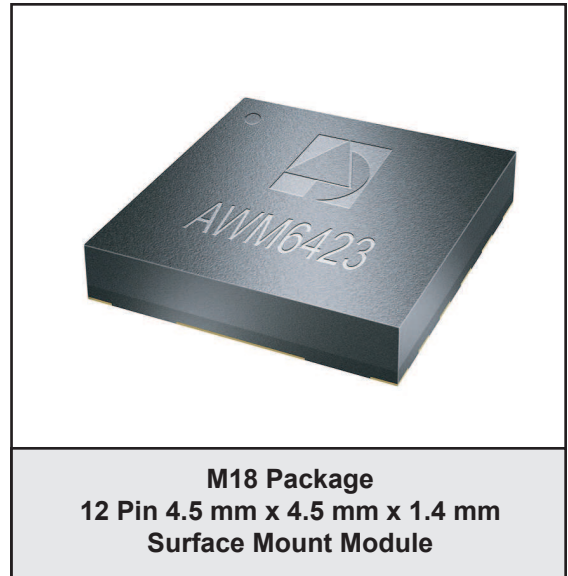

produces an increase in the maximum linear output power. The integrated detector can be used to monitor output power, and the integrated 25 dB step attenuator enables gain control. No external circuits are required for biasing or RF impedance matching, thus reducing external component costs and facilitating circuit board designs.

The AWM6423 is manufactured using advanced InGaP HBT technology that offers state-of-the-art reliability, temperature stability, and ruggedness. It is offered in a 4.5 mm x 4.5 mm x 1.4 mm surface mount module optimized for use in a 50 Ω system.

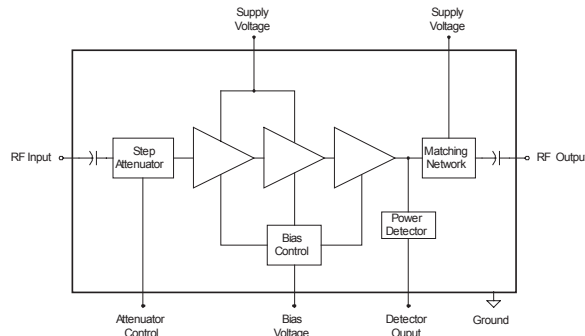

Figure 1: Functional Block Diagram

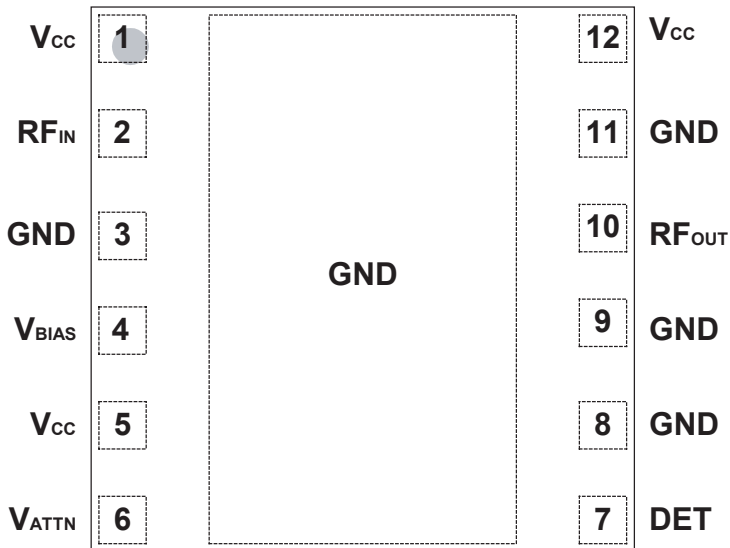

Figure 2: Pinout (X-ray Top View)

Table 1: Pin Description

PIN	NAME	DESCRIPTION
1	V _{CC}	Supply Voltage
2	RF _{IN}	RF Input
3	GND	Ground
4	V _{BIAS}	Bias/Shutdown
5	V _{CC}	Supply Voltage
6	V _{ATTN}	Attenuator Control
7	DET	Detector Output
8	GND	Ground
9	GND	Ground
10	RF _{OUT}	RF Output
11	GND	Ground
12	V _{CC}	Supply Voltage

ELECTRICAL CHARACTERISTICS

Table 2: Absolute Minimum and Maximum Ratings

PARAMETER	MIN	MAX	UNIT	COMMENTS
Supply Voltage (V_{CC})	0	+5.0	V	
Bias Voltage (V_{BIAS})	0	+3.0	V	
Attenuator Control Voltage (V_{ATTN})	0	+3.7	V	
RF Input Power	-	0	dBm	OFDM modulated signal
ESD Rating Human Body Model Charged Device Model	400 1,000	- -	V	Class 1A Class 3
MSL Level	3 4	- -	- -	235 °C Peak Reflow 250 °C Peak Reflow
Storage Temperature	-40	+150	°C	

Stresses in excess of the absolute ratings may cause permanent damage. Functional operation is not implied under these conditions. Exposure to absolute ratings for extended periods of time may adversely affect reliability.

Table 3: Operating Ranges

PARAMETER	MIN	TYP	MAX	UNIT	COMMENTS
Operating Frequency (f)	2500	-	2700	MHz	
Supply Voltage (V_{CC})	+2.9	+3.3	+4.2	V	
Bias Voltage (V_{BIAS})	+2.80 0	+2.85 -	+2.90 +0.7	V	PA"on" PA"shut down"
Attenuator Control Voltage (V_{ATTN}) Logic High Logic Low	+2.3 0	- -	+3.7 +0.7	V	Attenuator enabled Nominal gain
RF Output Power (P_{OUT})	-	+23.5	-	dBm	
Case Temperature (T_C)	-40	-	+85	°C	

The device may be operated safely over these conditions; however, parametric performance is guaranteed only over the conditions defined in the electrical specifications.

Table 4: Electrical Specifications
 (T_c = +25 °C, V_{CC} = +3.3 V, V_{BIAS} = +2.85 V, f = 2.7 GHz, 50 Ω system)

PARAMETER	MIN	TYP	MAX	UNIT	COMMENTS
Gain	27	31	33	dB	
Attenuator Step	23	25	27	dB	
Output Power Meets Spectrum Mask	-	+23.5	-	dBm	10 MHz Channel Bandwidth WiMAX user equipment coexistence emissions mask
EVM	- -	2.5 4	2.8 -	%	at +22 dBm P _{OUT} at +23.5 dBm P _{OUT}
Output P1dB	-	+30	-	dBm	CW
Output IP3	-	+41	-	dBm	two CW tones, +19 dBm output per tone
Harmonics	-	-35	-	dBc	at +23.5 dBm P _{OUT}
Power-Added Efficiency	-	20	-	%	at +23.5 dBm P _{OUT}
Power Detector Voltage at +24 dBm P _{OUT} at +14 dBm P _{OUT}	- -	+1.9 +0.6	- -	V	High impedance load
Quiescent Current	85	105	125	mA	
Current Consumption V _{CC} V _{CC} V _{BIAS} V _{ATTN}	- - - -	300 340 6.5 0.2	360 - 8.0 1.0	mA	at +22 dBm P _{OUT} at +23.5 dBm P _{OUT} Logic High = +3.3 V
Leakage Current ⁽²⁾	-	1.7	3.0	mA	PA shut down (V _{BIAS} = 0V) See figure 19 Application Circuit.

Notes:

1. All RF measurements performed with an 802.11g 54 Mbps OFDM signal unless otherwise noted.

(2) Lower leakage current may be obtained by using an alternate application circuit. Please refer to the ANADIGICS application note titled, "AWM6423 Reduced leakage current in Off State."

PERFORMANCE DATA

Figure 3: Gain vs. Output Power
 ($T_C = +25^\circ\text{C}$, $V_{CC} = +2.9\text{ V}$, $V_{BIAS} = +2.85\text{ V}$,
 54 Mbps OFDM Modulation)

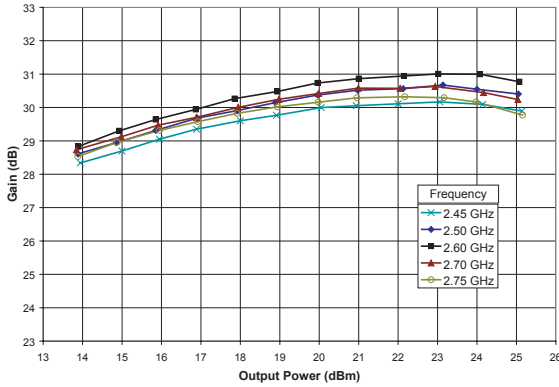

Figure 4: Uncorrected EVM vs. Output Power
 ($T_C = +25^\circ\text{C}$, $V_{CC} = +2.9\text{ V}$, $V_{BIAS} = +2.85\text{ V}$, 54 Mbps
 OFDM Modulation, system EVM approx. 0.8 %)

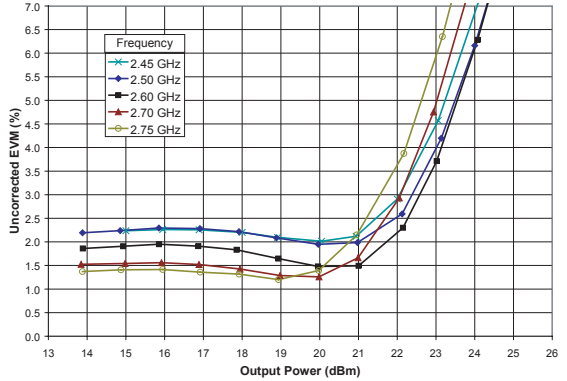

Figure 5: Gain vs. Output Power
 ($T_C = +25^\circ\text{C}$, $V_{CC} = +3.3\text{ V}$, $V_{BIAS} = +2.85\text{ V}$,
 54 Mbps OFDM Modulation)

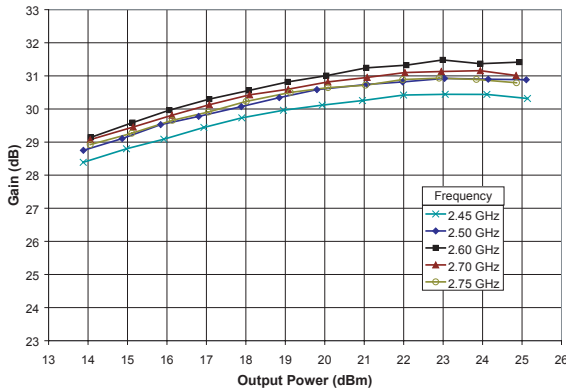

Figure 6: Uncorrected EVM vs. Output Power
 ($T_C = +25^\circ\text{C}$, $V_{CC} = +3.3\text{ V}$, $V_{BIAS} = +2.85\text{ V}$, 54 Mbps
 OFDM Modulation, system EVM approx. 0.8 %)

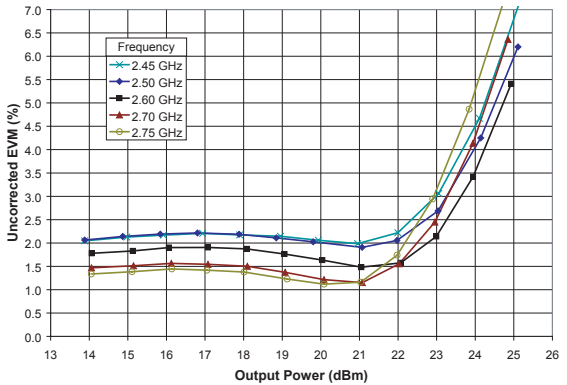

Figure 7: Gain vs. Output Power
 ($T_C = +25^\circ\text{C}$, $V_{CC} = +4.2\text{ V}$, $V_{BIAS} = +2.85\text{ V}$,
 54 Mbps OFDM Modulation)

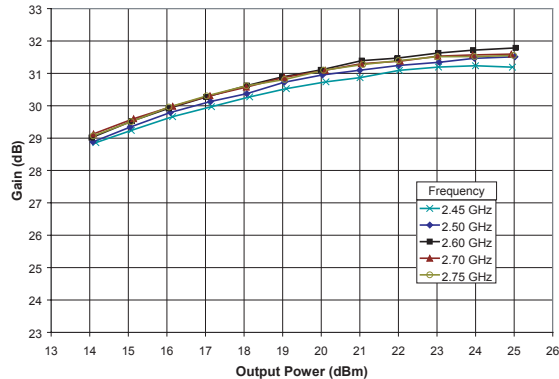

Figure 8: Uncorrected EVM vs. Output Power
 ($T_C = +25^\circ\text{C}$, $V_{CC} = +4.2\text{ V}$, $V_{BIAS} = +2.85\text{ V}$, 54 Mbps
 OFDM Modulation, system EVM approx. 0.8 %)

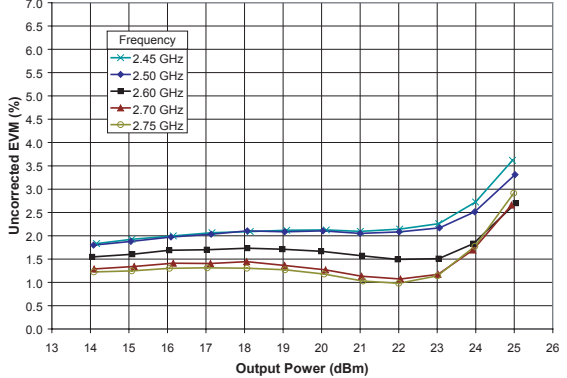

Figure 9: Gain vs. Frequency
 ($T_C = +25\text{ }^\circ\text{C}$, $V_{CC} = +3.3\text{ V}$, $V_{BIAS} = +2.85\text{ V}$,
 $P_{OUT} = +22\text{ dBm}$, 54 Mbps OFDM Modulation)

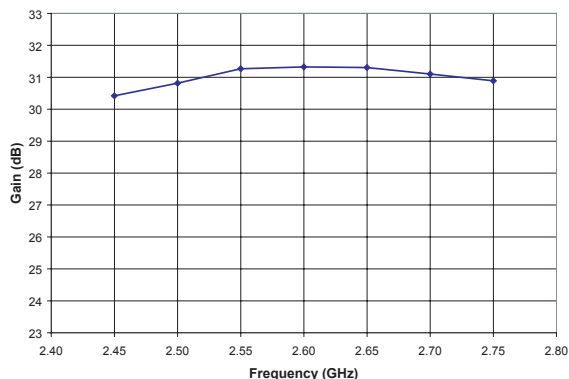

Figure 10: Uncorrected EVM vs. Frequency
 ($T_C = +25\text{ }^\circ\text{C}$, $V_{CC} = +3.3\text{ V}$, $V_{BIAS} = +2.85\text{ V}$, 54 Mbps
 OFDM Modulation, system EVM approx. 0.8 %)

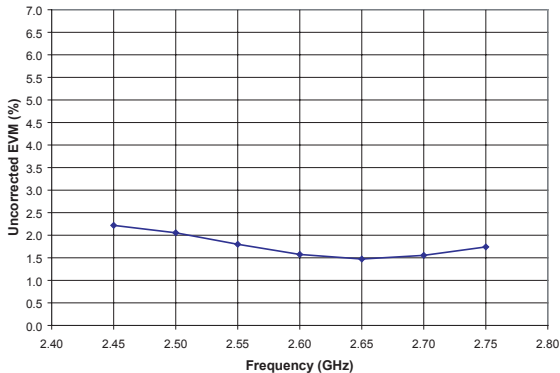

Figure 11: Supply Current vs. Output Power
 ($T_C = +25\text{ }^\circ\text{C}$, $V_{BIAS} = +2.85\text{ V}$, $f = 2.5\text{ GHz}$,
 54 Mbps OFDM Modulation)

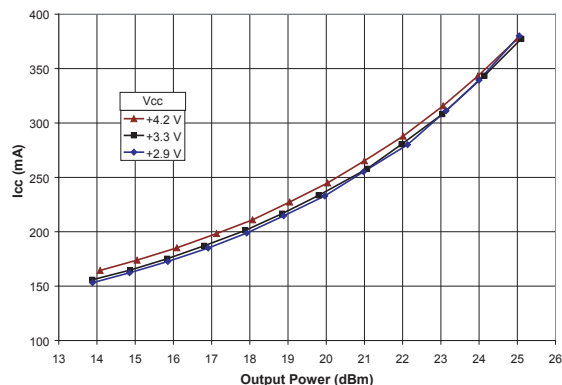

Figure 12: Effects of Bias Voltage (V_{BIAS}) on EVM
 ($T_C = +25\text{ }^\circ\text{C}$, $V_{CC} = +3.3\text{ V}$, $f = 2.6\text{ GHz}$, 54 Mbps
 OFDM Modulation, system EVM approx. 0.8 %)

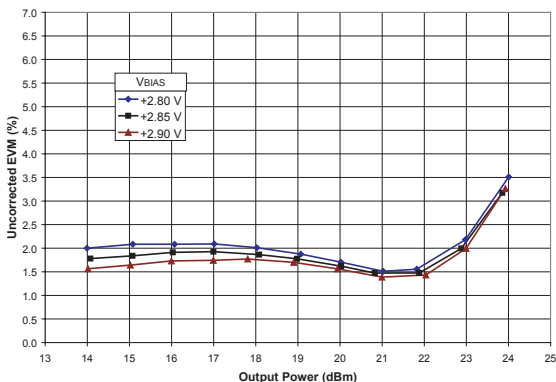

Figure 13: Detector Voltage vs. Output Power
 ($T_C = +25\text{ }^\circ\text{C}$, $V_{CC} = +3.3\text{ V}$, $V_{BIAS} = +2.85\text{ V}$,
 54 Mbps OFDM Modulation)

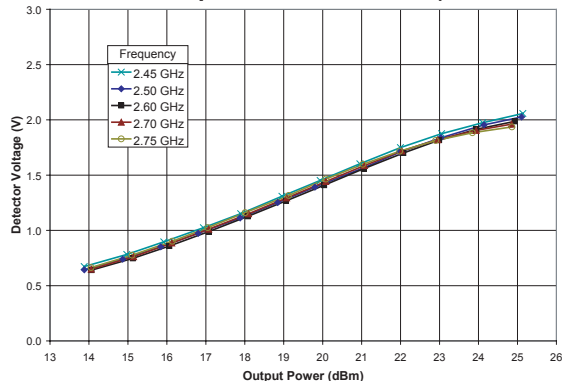

Figure 14: Effects of Supply Voltage (V_{CC}) on Detector Voltage
 ($T_C = +25\text{ }^\circ\text{C}$, $V_{BIAS} = +2.85\text{ V}$,
 $f = 2.6\text{ GHz}$, 54 Mbps OFDM Modulation)

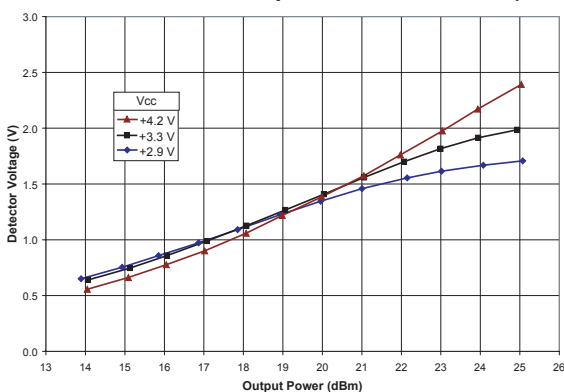

Figure 15: Gain vs. Case Temperature
($V_{CC} = +3.3\text{ V}$, $V_{BIAS} = +2.85\text{ V}$, $f = 2.6\text{ GHz}$,
 $P_{OUT} = +22\text{ dBm}$, 54 Mbps OFDM Modulation)

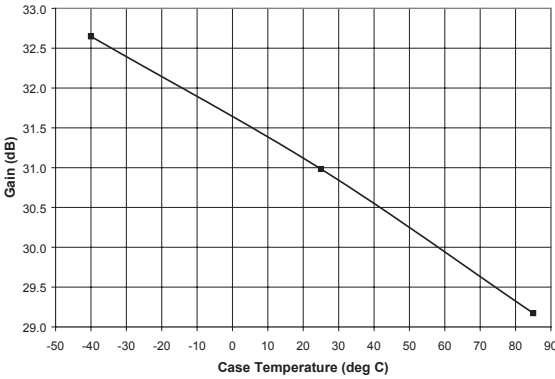

Figure 16: Effects of Case Temperature on EVM
($V_{CC} = +3.3\text{ V}$, $V_{BIAS} = +2.85\text{ V}$, $f = 2.6\text{ GHz}$, 54 Mbps
OFDM Modulation, system EVM approx. 0.8 %)

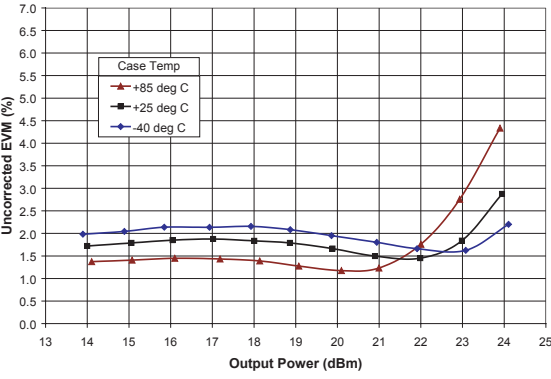

Figure 17: Supply Current vs. Case Temperature
($V_{CC} = +3.3\text{ V}$, $V_{BIAS} = +2.85\text{ V}$, $f = 2.6\text{ GHz}$,
 $P_{OUT} = +22\text{ dBm}$, 54 Mbps OFDM Modulation)

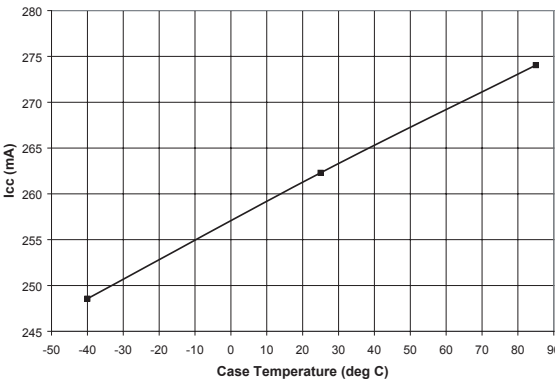
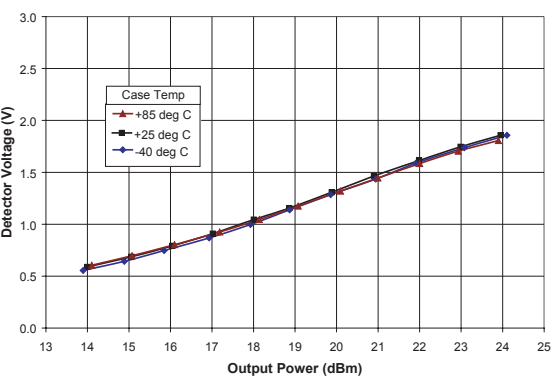

Figure 18: Effects of Case Temperature on Detector Voltage
($V_{CC} = +3.3\text{ V}$, $V_{BIAS} = +2.85\text{ V}$,
 $f = 2.6\text{ GHz}$, 54 Mbps OFDM Modulation)



APPLICATION INFORMATION

Transmit Disable and Attenuator Control

The power amplifier is disabled by setting V_{BIAS} below +0.7 V. The step attenuator is enabled by applying a logic high to V_{ATTN} ; the PA exhibits nominal gain when a logic low is applied to V_{ATTN} .

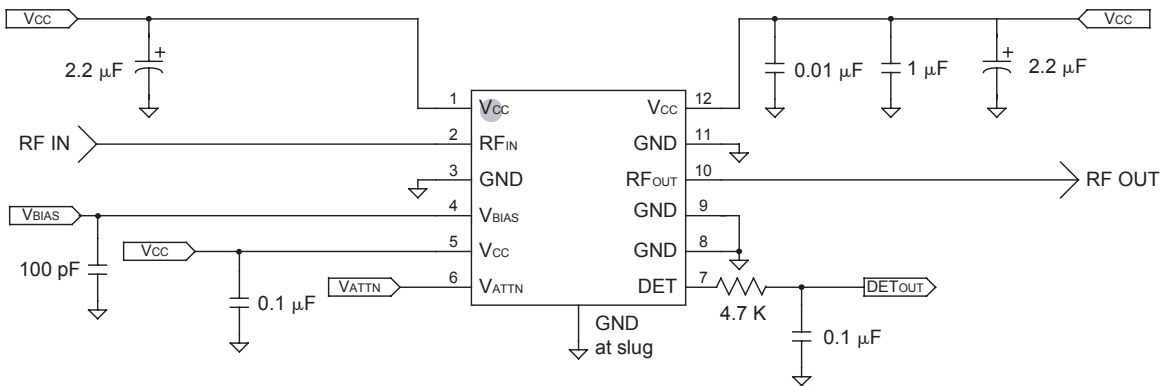
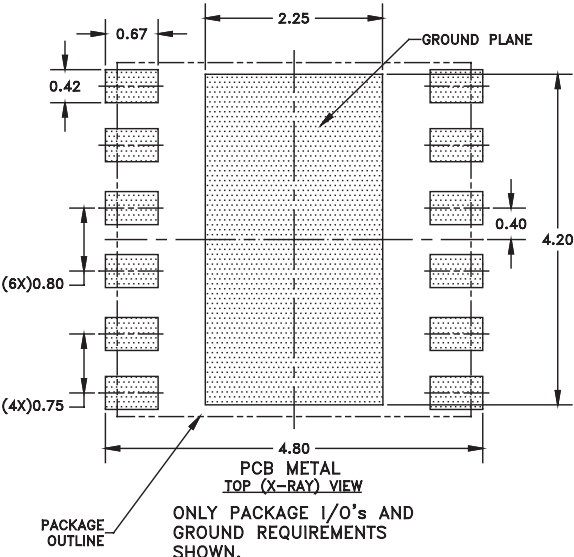

Figure 19: Application Circuit



- NOTES:
- (1) UNLESS SPECIFIED DIMENSIONS ARE SYMMETRICAL ABOUT CENTER LINES SHOWN.
 - (2) DIMENSIONS IN MILLIMETERS.

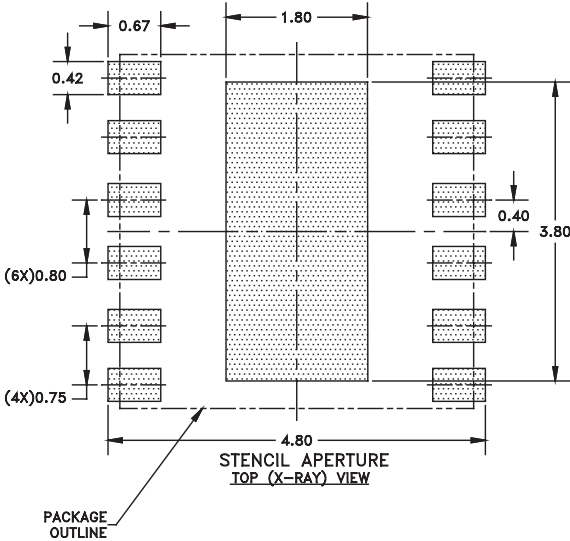
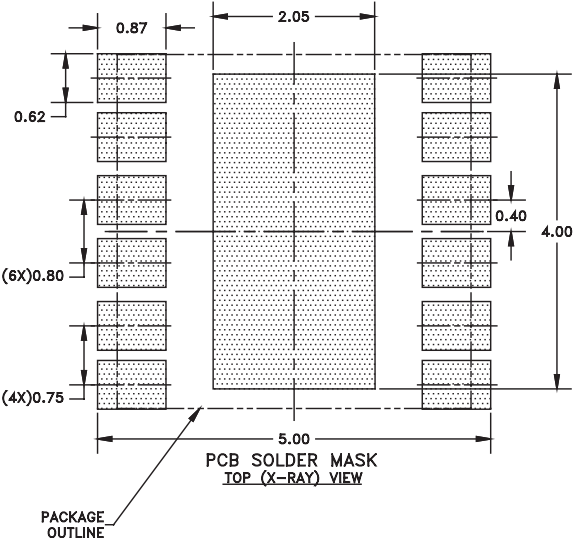
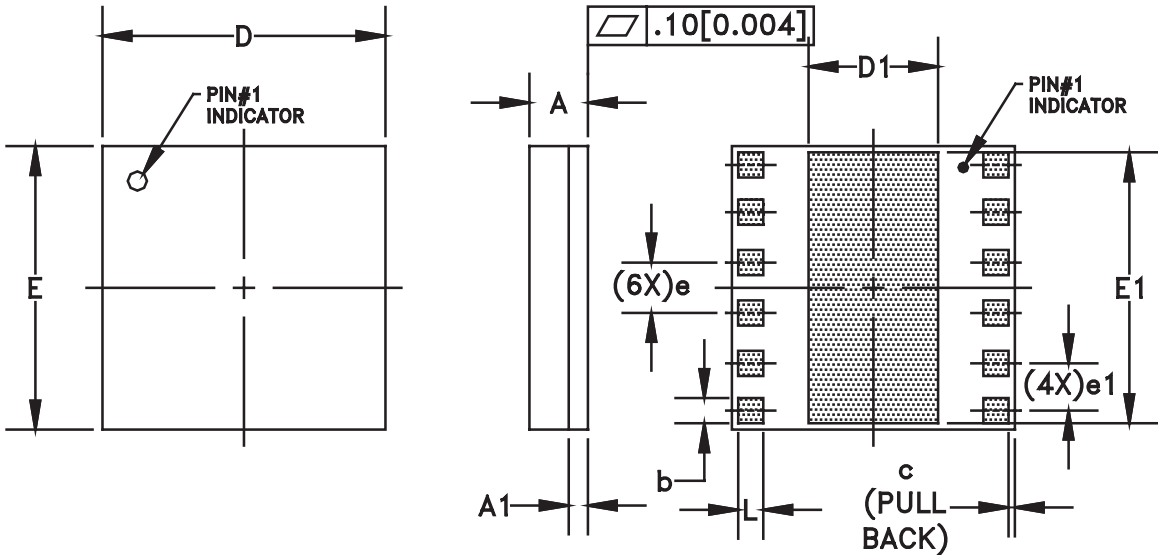

Figure 20: Land Pattern

PACKAGE OUTLINE



DIM	MILLIMETERS			INCHES			NOTE
	MIN.	NOM.	MAX.	MIN.	NOM.	MAX.	
A	1.26	1.41	1.56	0.049	0.055	0.061	—
A1	—	0.30	—	—	0.012	—	—
b	0.32	—	0.52	0.013	—	0.020	3
c	—	0.10	—	—	0.004	—	—
D	4.38	4.50	4.62	0.172	0.177	0.182	—
D1	1.97	—	2.13	0.078	—	0.084	—
E	4.38	4.50	4.62	0.172	0.177	0.182	—
E1	4.22	—	4.38	0.166	—	0.172	—
e	—	0.80	—	—	0.032	—	3
e1	—	0.75	—	—	0.030	—	3,4
L	0.32	—	0.52	0.013	—	0.020	3

NOTES:

1. CONTROLLING DIMENSIONS: MILLIMETERS
2. UNLESS SPECIFIED TOLERANCE=±0.076[0.003].
3. PADS (INCLUDING CENTER) SHOWN UNIFORM SIZE FOR REFERENCE ONLY. ACTUAL PAD SIZE AND LOCATION WILL VARY WITHIN MIN. AND MAX. DIMENSIONS ACCORDING TO SPECIFIC LAMINATE DESIGN.
4. DIMENSION e1 FOUR CORNERS.

Figure 21: M18 Package Outline - 12 Pin 4.5 mm x 4.5 mm x 1.4 mm Surface Mount Module

NOTES

ORDERING INFORMATION

ORDER NUMBER	TEMPERATURE RANGE	PACKAGE DESCRIPTION	COMPONENT PACKAGING
AWM6423RM18P8	-40 °C to +85 °C	12 Pin 4.5 mm x 4.5 mm x 1.4 mm Surface Mount Module	2,500 piece Tape and Reel

**ANADIGICS, Inc.**

141 Mount Bethel Road
Warren, New Jersey 07059, U.S.A.

Tel: +1 (908) 668-5000

Fax: +1 (908) 668-5132

URL: <http://www.anadigics.com>

E-mail: Mktg@anadigics.com

IMPORTANT NOTICE

ANADIGICS, Inc. reserves the right to make changes to its products or to discontinue any product at any time without notice. The product specifications contained in Advanced Product Information sheets and Preliminary Data Sheets are subject to change prior to a product's formal introduction. Information in Data Sheets have been carefully checked and are assumed to be reliable; however, ANADIGICS assumes no responsibilities for inaccuracies. ANADIGICS strongly urges customers to verify that the information they are using is current before placing orders.

WARNING

ANADIGICS products are not intended for use in life support appliances, devices or systems. Use of an ANADIGICS product in any such application without written consent is prohibited.