

FEATURES

- InGaP HBT Technology
- < 3.5% EVM at +25 dBm Output Power (+5 V Supply), with 802.11g Modulation at 54 Mbps Data Rate
- < 3% EVM at +21 dBm Output Power (+3.3 V Supply), with 802.11g Modulation at 54 Mbps Data Rate
- +3 V to +5 V Supply
- High Efficiency
- 50Ω - Matched RF Ports for Reduced External Component Count
- 4 mm x 4 mm x 1.4 mm Surface Mount Module, Materials Set Consistent with RoHS Directives.

APPLICATIONS

- 802.11g/b WLAN Stations and Client Cards
- 802.11g/b WLAN Access Points

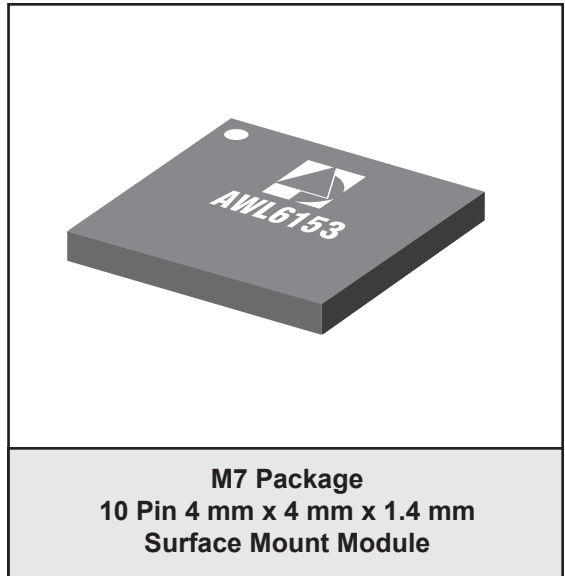

PRODUCT DESCRIPTION

The ANADIGICS AWL6153 WLAN Power Amplifier is an easy to use module that delivers high levels of linearity and efficiency for high data rate applications. Designed for the 2.4 GHz WLAN standards, it supports the 54 Mbps data rates specified in IEEE 802.11g.

Requiring a single +3 V to +5 V supply and a reference voltage input, the AWL6153 reduces system power consumption by offering a low leakage current while the amplifier is shut down. No external circuits are required for RF impedance matching, thus reducing

component costs and making it easy to incorporate the device into new designs.

The AWL6153 is manufactured using an advanced InGaP HBT technology that offers state-of-the-art reliability, temperature stability and ruggedness. It is offered in a 4 mm x 4 mm x 1.4 mm surface mount module optimized for a 50Ω system.

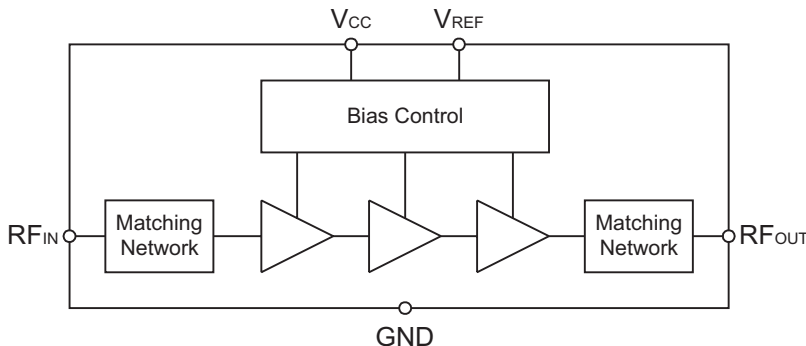

Figure 1: Module Block Diagram

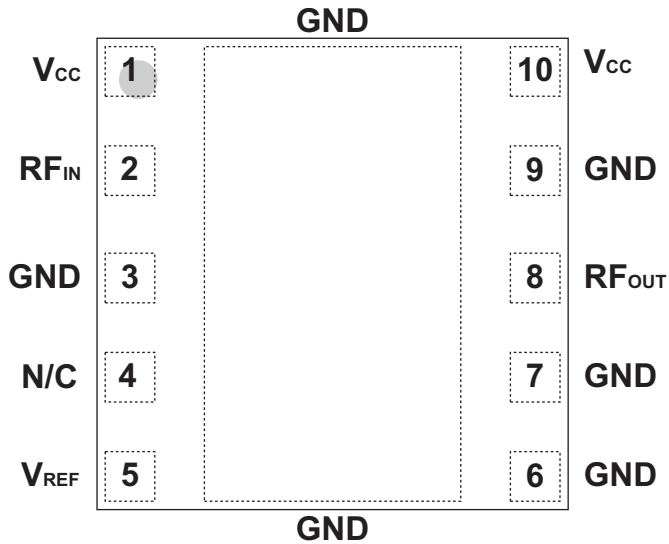

Figure 2: Pinout (X-ray Top View)

Table 1: Pin Description

PIN	NAME	DESCRIPTION
1	V _{CC}	Supply Voltage
2	RF _{IN}	RF Input
3	GND	Ground
4	N/C	No Connection
5	V _{REF}	Reference Voltage
6	GND	Ground
7	GND	Ground
8	RF _{OUT}	RF Output
9	GND	Ground
10	V _{CC}	Supply Voltage

ELECTRICAL CHARACTERISTICS

Table 2: Absolute Minimum and Maximum Ratings

PARAMETER	MIN	MAX	UNIT	COMMENTS
Supply Voltage (V_{CC})	0	+5.5	V	
Reference Voltage (V_{REF})	0	+3.5	V	
RF Input Power (P_{IN})	-	+10	dBm	
ESD Rating Human Body Model Charged Device Model	300 800	- -	V	Class 1A Class 3
MSL Rating	3	-	-	250 °C Peak Reflow
Storage Temperature	-40	+150	°C	

Stresses in excess of the absolute ratings may cause permanent damage. Functional operation is not implied under these conditions. Exposure to absolute ratings for extended periods of time may adversely affect reliability.

Table 3: Operating Ranges

PARAMETER	MIN	TYP	MAX	UNIT	COMMENTS
Operating Frequency (f)	2400	-	2485	MHz	
Supply Voltage (V_{CC})	+3.0	-	+5.5	V	
Reference Voltage (V_{REF})	- 0	+2.85 -	- +0.5	V	PA"on" PA"shut down"
RF Output Power (P_{OUT})	- - - -	+21 +25 +25 +28	- - - -	dBm	V_{CC} = +3.3 V, 802.11g modulation V_{CC} = +5.0 V, 802.11g modulation V_{CC} = +3.3 V, 802.11b modulation V_{CC} = +5.0 V, 802.11b modulation
Case Temperature (T_C)	-40	-	+85	°C	

The device may be operated safely over these conditions; however, parametric performance is guaranteed only over the conditions defined in the electrical specifications.

Table 4: Electrical Specifications - 802.11g Modulation, 54 Mbps Data Rate
(T_c = +25 °C, V_{CC} = +3.3 V, V_{REF} = +2.85 V, P_{OUT} = +21 dBm, 50 Ω system)

PARAMETER	MIN	TYP	MAX	UNIT	COMMENTS
Gain	-	29.5	-	dB	
Gain at 2472 MHz	27.5	-	-	dB	
Gain Ripple	-	-	0.3	dB	within each channel
Constellation RMS Error	-	3	-	%	
	-	-30	-	dB	
Spectrum Mask at ± 11 MHz Offset	-	-	-20	dB	
Spectrum Mask at ± 20 MHz Offset	-	-	-28	dB	
Spectrum Mask at ± 30 MHz Offset	-	-	-40	dB	
Current Consumption					
V _{CC}	-	160	-	mA	
V _{REF}	-	5.5	-		
Leakage Current	-	<10	-	μA	V _{REF} = 0 V
Input Return Loss	-	<-10	-	dB	50 Ω impedance
P1dB	-	+28	-	dBm	CW tone
Harmonics					
2fo	-	-45	-	dBc	
3fo	-	-56	-		
On Time	-	1.5	2.0	μsec	Output power achieves 90% of steady-state level ⁽¹⁾ , V _{REF} toggled from 0 V to +2.85 V
Maximum load mismatch stress with no permanent degradation or failure	10:1	-	-	VSWR	V _{CC} = +5.5 V

Note:

(1) Steady-state output is defined as a power level that is consistent or changing at a rate less than 0.05 dB/μsec.

Table 5: Electrical Specifications - 802.11g Modulation, 54 Mbps Data Rate
(T_C = +25 °C, V_{CC} = +5 V, V_{REF} = +2.85 V, P_{OUT} = +25 dBm, 50 Ω system)

PARAMETER	MIN	TYP	MAX	UNIT	COMMENTS
Gain	-	30.5	-	dB	
Gain at 2472 MHz	28.5	-	-	dB	
Gain Ripple	-	-	0.3	dB	within each channel
Constellation RMS Error	-	3.5	-	%	
	-	-29	-	dB	
Spectrum Mask at ± 11 MHz Offset	-	-	-20	dB	
Spectrum Mask at ± 20 MHz Offset	-	-	-28	dB	
Spectrum Mask at ± 30 MHz Offset	-	-	-40	dB	
Current Consumption					
V _{CC}	-	240	-	mA	
V _{REF}	-	5.5	-		
Leakage Current	-	<10	-	μA	V _{REF} = 0 V
Input Return Loss	-	<-10	-	dB	50 Ω impedance
P1dB	-	+31	-	dBm	CW tone
Harmonics					
2fo	-	-42	-	dBc	
3fo	-	-56	-		
On Time	-	1.5	2.0	μsec	Output power achieves 90% of steady-state level ⁽¹⁾ , V _{REF} toggled from 0 V to +2.85 V
Maximum load mismatch stress with no permanent degradation or failure	10:1	-	-	VSWR	V _{CC} = +5.5 V

Note:

(1) Steady-state output is defined as a power level that is consistent or changing at a rate less than 0.05 dB/μsec.

Table 6: Electrical Specifications - 802.11b Modulation
(T_c = +25 °C, V_{CC} = +3.3 V, V_{REF} = +2.85 V, P_{OUT} = +25 dBm, 50 Ω system)

PARAMETER	MIN	TYP	MAX	UNIT	COMMENTS
Gain	-	29.5	-	dB	
Gain at 2472 MHz	27.5	-	-	dB	
First Sidelobe Power	-	-	-30	dBc	Gaussian Filtering
Second Sidelobe Power	-	-	-50	dBc	Gaussian Filtering
Current Consumption V _{CC} V _{REF}	- - -	250 5.5	- -	mA	
Leakage Current	-	<10	-	μA	V _{REF} = 0 V
Input Return Loss	-	<-10	-	dB	50 Ω impedance
P1dB	-	+28	-	dBm	CW tone
Harmonics 2fo 3fo	- - -	-50 -63	- -	dBc	CW Input
On Time	-	1.5	2.0	μsec	Output power achieves 90% of steady-state level ⁽¹⁾ , V _{REF} toggled from 0 V to +2.85 V
Maximum load mismatch stress with no permanent degradation or failure	10:1	-	-	VSWR	V _{CC} = +5.5 V

Note:

(1) Steady-state output is defined as a power level that is consistent or changing at a rate less than 0.05 dB/μsec.

Table 7: Electrical Specifications - 802.11b Modulation
 (T_C = +25 °C, V_{CC} = +5 V, V_{REF} = +2.85 V, P_{OUT} = +28 dBm, 50 Ω system)

PARAMETER	MIN	TYP	MAX	UNIT	COMMENTS
Gain	-	30.5	-	dB	
Gain at 2472 MHz	28.5	-	-	dB	
First Sidelobe Power	-	-	-30	dBc	Gaussian Filtering
Second Sidelobe Power	-	-	-50	dBc	Gaussian Filtering
Current Consumption V _{CC} V _{REF}	- -	350 5.5	- -	mA	
Leakage Current	-	<10	-	μA	V _{REF} = 0 V
Input Return Loss	-	<-10	-	dB	50 Ω impedance
P1dB	-	+31	-	dBm	CW tone
Harmonics 2fo 3fo	- -	-50 -63	- -	dBc	CW Input
On Time	-	1.5	2.0	μsec	Output power achieves 90% of steady-state level ⁽¹⁾ , V _{REF} toggled from 0 V to +2.85 V
Maximum load mismatch stress with no permanent degradation or failure	10:1	-	-	VSWR	V _{CC} = +5.5 V

Note:

(1) Steady-state output is defined as a power level that is consistent or changing at a rate less than 0.05 dB/μsec.

PERFORMANCE DATA

Figure 3: EVM and Gain vs Frequency
 (T_A = +25 °C, V_{CC} = +3.3 V, V_{REF} = +2.85 V,
 P_{OUT} = +21 dBm, 54 Mbps 802.11g)

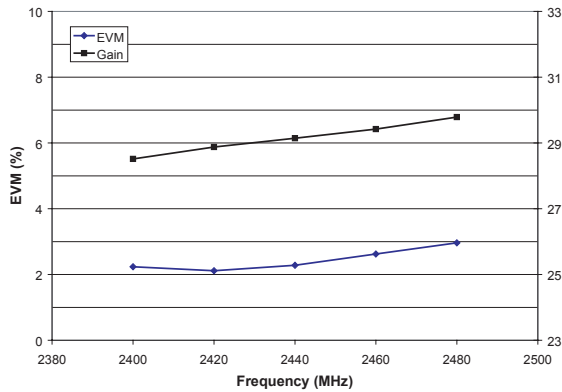

Figure 4: EVM and Gain vs Frequency
 (T_A = +25 °C, V_{CC} = +5 V, V_{REF} = +2.85 V,
 P_{OUT} = +25 dBm, 54 Mbps 802.11g)

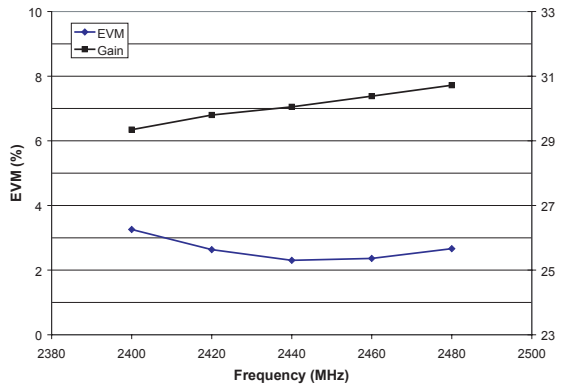

Figure 5: Gain and Current Consumption vs Output Power
 (T_A = +25 °C, V_{CC} = +3.3 V,
 V_{REF} = +2.85 V, f = 2472 MHz, 54 Mbps 802.11g)

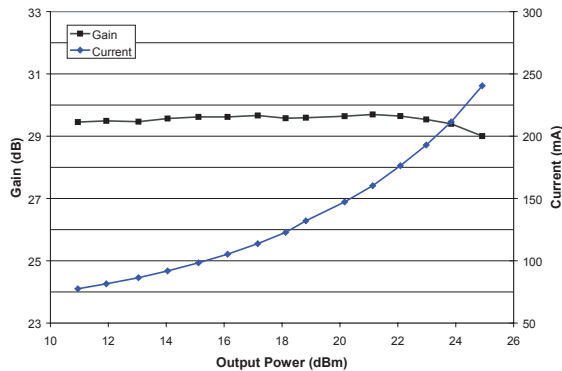

Figure 6: Gain and Current Consumption vs. Output Power
 (T_A = +25 °C, V_{CC} = +5 V,
 V_{REF} = +2.85 V, f = 2472 MHz, 54 Mbps 802.11g)

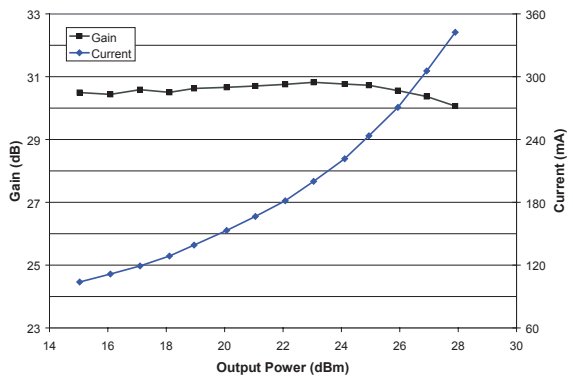

Figure 7: Gain and Current Consumption vs. V_{REF} ($T_A = +25\text{ }^\circ\text{C}$, $V_{CC} = +3.3\text{ V}$, $f = 2472\text{ MHz}$, $P_{OUT} = +21\text{ dBm}$, 54 Mbps 802.11g)

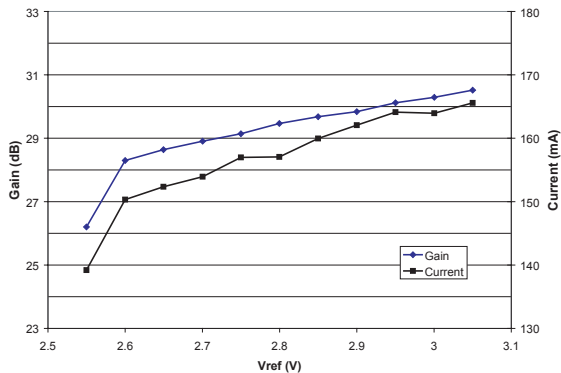

Figure 8: Gain and Current Consumption vs. V_{REF} ($T_A = +25\text{ }^\circ\text{C}$, $V_{CC} = +5\text{ V}$, $f = 2472\text{ MHz}$, $P_{OUT} = +25\text{ dBm}$, 54 Mbps 802.11g)

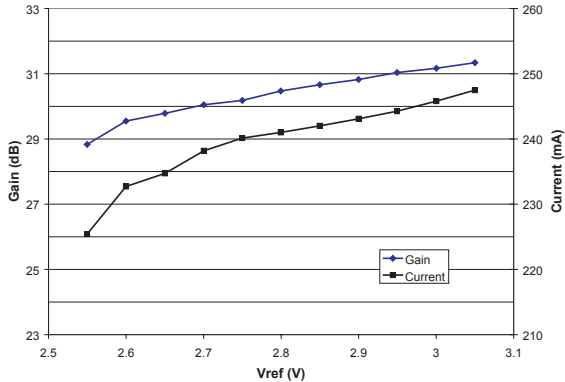

Figure 9: EVM vs V_{REF} ($T_A = +25\text{ }^\circ\text{C}$, $f = 2472\text{ MHz}$, 54 Mbps 802.11g)

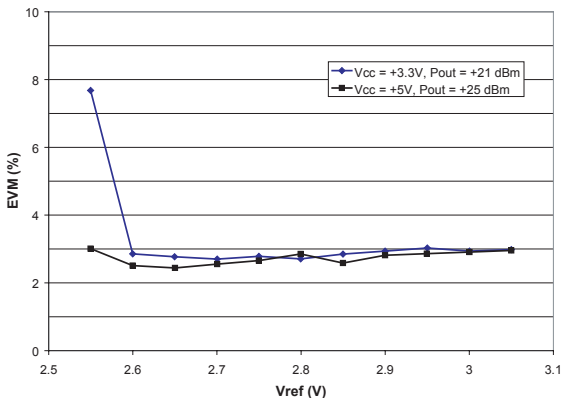
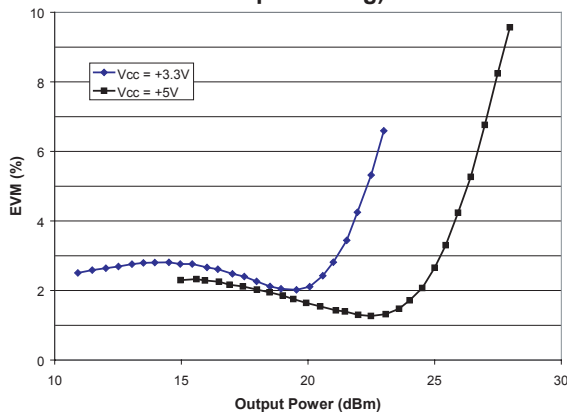

Figure 10: EVM vs. Output Power ($T_A = +25\text{ }^\circ\text{C}$, $V_{REF} = +2.85\text{ V}$, $f = 2472\text{ MHz}$, 54 Mbps 802.11g)



APPLICATION INFORMATION

The only external components required for the AWL6153 are bypass capacitors for the supply (see

Figure 11). When V_{REF} is pulled down to 0 V, the amplifier is placed in a low-current shut down mode.

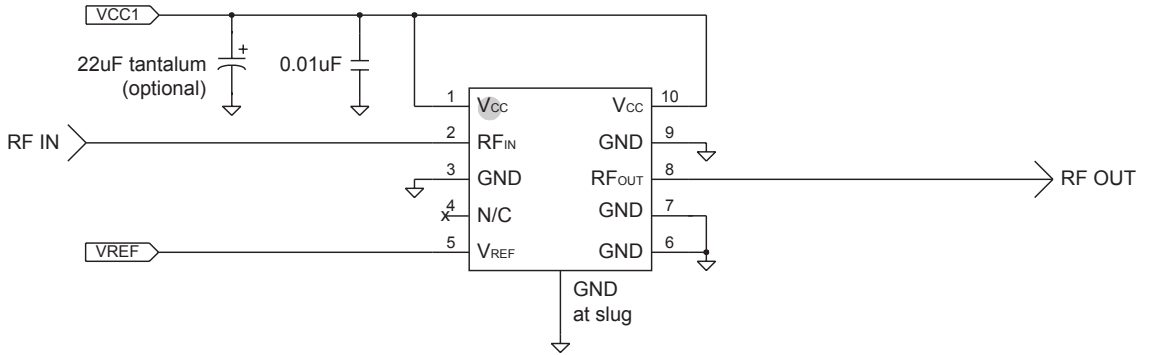
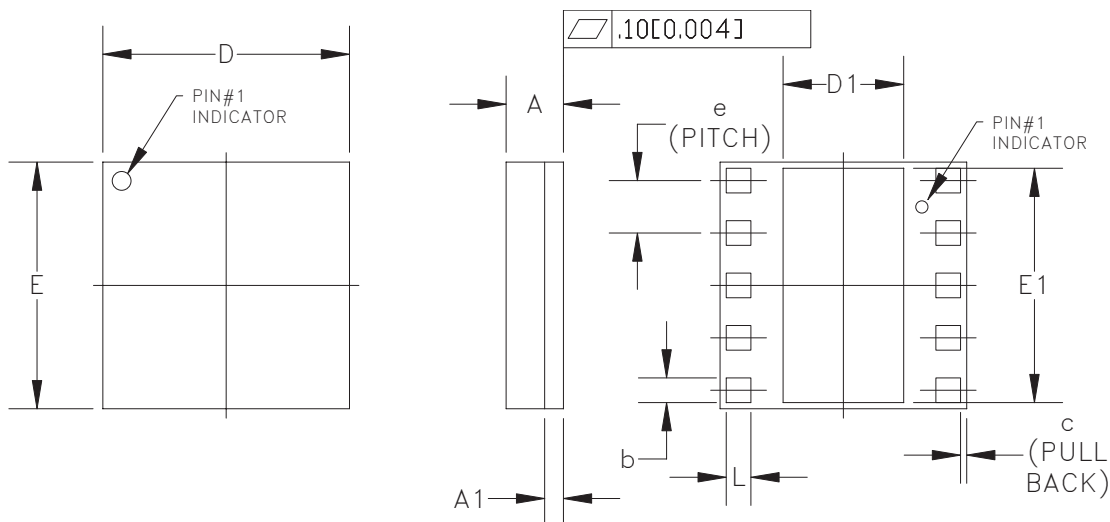

Figure 11: Application Circuit

PACKAGE OUTLINE



SYMBOL	MILLIMETERS			INCHES			NOTE
	MIN.	NOM.	MAX.	MIN.	NOM.	MAX.	
A	1.26	1.41	1.56	0.049	0.055	0.061	-
A1	-	0.30	-	-	0.012	-	-
b	0.35	-	0.60	0.013	-	0.024	3
c	-	0.10	-	-	0.004	-	-
D	3.88	4.00	4.12	0.152	0.157	0.162	-
D1	1.90	-	2.20	0.075	-	0.086	-
E	3.88	4.00	4.12	0.152	0.157	0.162	-
E1	3.75	-	3.85	0.148	-	0.152	-
e		0.85			0.033		3
L	0.35	-	0.60	0.013	-	0.024	3

NOTES:

1. CONTROLLING DIMENSIONS: MILLIMETERS
2. UNLESS SPECIFIED TOLERANCE=±0.076[0.003].
3. PADS (INCLUDING CENTER) SHOWN UNIFORM SIZE FOR REFERENCE ONLY. ACTUAL PAD SIZE AND LOCATION WILL VARY WITHIN MIN. AND MAX. DIMENSIONS ACCORDING TO SPECIFIC LAMINATE DESIGN.

Figure 12: M7 Package Outline - 10 Pin 4 mm x 4 mm x 1.4 mm Surface Mount Module

ORDERING INFORMATION

ORDER NUMBER	TEMPERATURE RANGE	PACKAGE DESCRIPTION	COMPONENT PACKAGING
AWL6153M7UP8	-40°C to +85°C	10 Pin 4 mm x 4 mm x 1.4 mm Surface Mount Module	2,500 piece Tape and Reel

**ANADIGICS, Inc.**

141 Mount Bethel Road

Warren, New Jersey 07059, U.S.A.

Tel: +1 (908) 668-5000

Fax: +1 (908) 668-5132

URL: <http://www.anadigics.com>**IMPORTANT NOTICE**

ANADIGICS, Inc. reserves the right to make changes to its products or to discontinue any product at any time without notice. The product specifications contained in Advanced Product Information sheets and Preliminary Data Sheets are subject to change prior to a product's formal introduction. Information in Data Sheets have been carefully checked and are assumed to be reliable; however, ANADIGICS assumes no responsibilities for inaccuracies. ANADIGICS strongly urges customers to verify that the information they are using is current before placing orders.

WARNING

ANADIGICS products are not intended for use in life support appliances, devices or systems. Use of an ANADIGICS product in any such application without written consent is prohibited.