

**FEATURES**

- 3% Dynamic EVM @ Pout = +18 dBm with IEEE 802.11a 64 QAM OFDM at 54 Mbps
- 30 dB of Linear Power Gain
- Single +3.3 V Nominal Supply
- SP3T RF Switch w/Bluetooth and 2 GHz Band Tx/Rx
- 1.0 dB 2 GHz Band RF Switch Tx Path Insertion Loss
- 1.6 dB 2 GHz Band RF Switch BT & Rx Path Insertion Loss
- SP2T RF Switch for 5 GHz Band Tx/Rx Function
- 2.7 dB 5 GHz Band RF Switch Rx Path Insertion Loss
- 5 GHz Band TX Power Detector
- 1.8 V CMOS Logic Level Control
- 50 Ω-Matched RF Ports
- Leadfree and RoHS Compliant
- 3 x 3 x 0.55 mm QFN Package

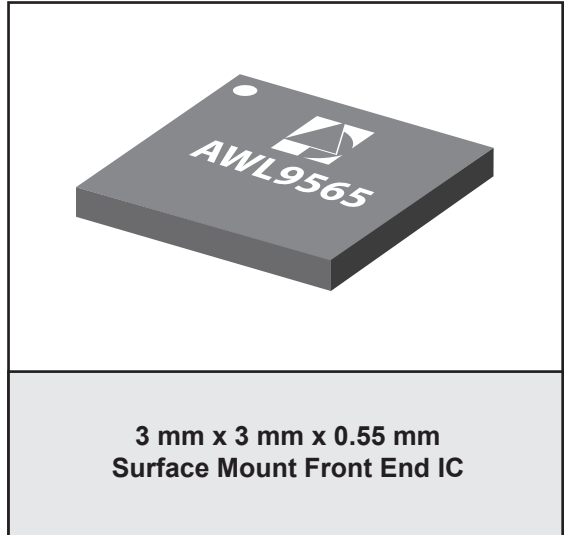

**APPLICATIONS**

- 802.11a/b/g/n WLAN +Bluetooth for Fixed, Mobile, and Handheld applications.

The AWL9565 is manufactured using advanced InGaP HBT technology that offers state-of-the-art reliability, temperature stability and ruggedness.

**PRODUCT DESCRIPTION**

The ANADIGICS AWL9565 is a high performance InGaP HBT FEIC that incorporates a 5 GHz power amplifier, 5 GHz SP2T RF Switch and 2 GHz SP3T RF switch. The FEIC is designed for WLAN transmit and receive applications in the 2.412-2.484 and 5.15-5.85 GHz bands. Matched to 50 Ohms and DC blocked at all RF inputs and outputs, the part requires no additional RF matching components off-chip. The antenna ports are switched between WLAN transmit, WLAN receive, Bluetooth, and simultaneous WLAN and Bluetooth paths with low loss RF switches. The PA exhibits unparalleled linearity and efficiency for IEEE 802.11a/n WLAN systems under the toughest signal configurations within the standard.

An on-chip power detector is incorporated in 5 GHz transmit path of the FEIC. All control circuits operate with +1.8 V CMOS logic and consume ultra-low current in the OFF mode.

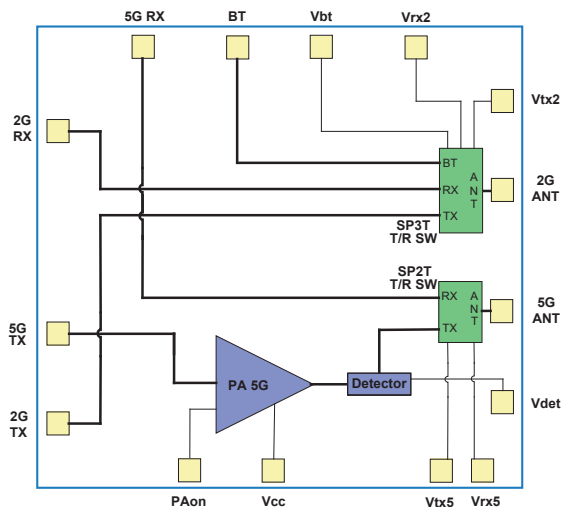

**Figure 1: Block Diagram**

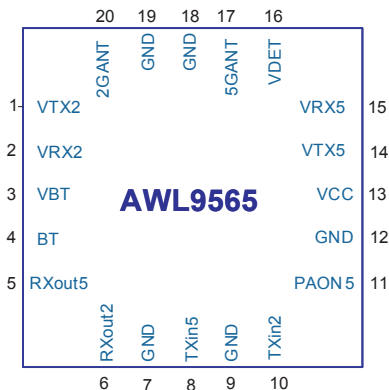

Figure 2: Pinout Diagram

Table 1: Pin Description Table

PIN	NAME	DESCRIPTION	PIN	NAME	DESCRIPTION
1	VTX2	Switch control 2 GHz transmit path	11	PAON5	5 GHz PA enable. On /Off control 5 GHz transmit path power amplifier
2	VRX2	Switch control for 2 GHz receive path	12	GND	Ground
3	VBT	Switch control for Bluetooth path	13	Vcc	Power Supply. Bias for transistors
4	BT	Bluetooth RF port	14	VTX5	Switch control for 5 GHz transmit path
5	RX <sub>OUT5</sub>	5 GHz RF receive output port	15	VRX5	Switch control 5 GHz receive path
6	RX <sub>OUT2</sub>	2 GHz RF receive output port	16	VDET	Power detector output. DC coupled
7	GND	Ground	17	5GANT	5 GHz antenna port
8	TX <sub>IN5</sub>	5 GHz RF transmit input port	18	GND	Ground
9	GND	Ground	19	GND	Ground
10	TX <sub>IN2</sub>	2 GHz RF transmit input port	20	2GANT	2 GHz antenna port

## ELECTRICAL CHARACTERISTICS

Table 2: Absolute Minimum and Maximum Ratings

PARAMETER	MIN	MAX	UNIT	COMMENTS
DC Power Supply	-	+6.0	V	
RF Input Level, 5 GHz PA	-	+5	dBm	Modulated
Operating Ambient Temperature	-40	+85	°C	
Storage Temperature	-55	+85	°C	
Storage Humidity	-	60	%	
Junction Temperature	-	150	°C	
ESD Tolerance	400	-	V	Human body model (HBM)
MSL Rating	-	MSL-2		

*Stresses in excess of the absolute ratings may cause permanent damage. Functional operation is not implied under these conditions. Exposure to absolute ratings for extended periods of time may adversely affect reliability.*

Table 3: Operating Ranges

PARAMETER	MIN	TYP	MAX	UNIT	COMMENTS
Operating Frequency Ranges	2412 5150	- -	2484 5850	MHz	802.11b/g/n 802.11a/n
DC Power Supply Voltage ( $V_{CC}$ )	+2.8	+3.3	+4.8	V	With RF applied
Control Pin Voltage ( $PA_{ON}$ , $V_{bt}$ , $V_{rx2}$ , $V_{tx2}$ , $V_{rx5}$ , $V_{tx5}$ )	+1.4 0	+1.8 0	+ $V_{CC}$ +0.5	V	Logic High/On Logic Low/Off
Operating Ambient Temperature	-40	-	+85	°C	

*The device may be operated safely over these conditions; however, parametric performance is guaranteed only over the conditions defined in the electrical specifications.*

Table 4: Electrical Specifications - 802.11a/n Transmit Path

(T<sub>c</sub> = +25 °C, V<sub>CC</sub> = +3.3 V, P<sub>AON</sub> = +1.8 V, V<sub>tx5</sub> = +1.8 V, V<sub>rx5</sub> = 0 V, Static Mode 64 QAM OFDM 54 Mbps)

PARAMETER	MIN	TYP	MAX	UNIT	COMMENTS	
Operating Frequency	5150	-	5850	MHz		
Power Gain	27	30	33	dB		
Gain Flatness	-	+/-1.5	-	dB	Across full band	
	-	+/-0.2	-	dB	Across any 40 MHz band	
Error Vector Magnitude (EVM) <sup>(1)</sup> Current Consumption	-	-32	-	dB	P <sub>OUT</sub> = 17 dBm, Dyn Mode, 54 Mbps Avg current during packet	
	-	135	-	mA		
	-	-33	-29	dB	P <sub>OUT</sub> = 16 dBm, Dyn Mode, 54 Mbps Avg current during packet	
	-	125	150	mA		
	-	-36	-	dB	P <sub>OUT</sub> = 5 dBm, Dyn Mode, 54 Mbps Avg current during packet	
	-	75	-	mA		
Transmit Mask	18.5	20.5	-	dBm	802.11a, 6 Mbps, OFDM 802.11n, 6.5 Mbps, HT, 20 MHz CH 802.11n, 6.5 Mbps, HT, 40 MHz CH	
	15.5	18.0	-			
	15.0	17.5	-			
PA Noise Figure	-	6	-	dB		
Psat	-	24.5	-	dBm		
Group Delay	-	1.5	-	ns		
Group Delay Variation	-	0.5	-	ns	For any 20 MHz channel	
Input Return Loss	5	8	-	dB		
Output Return Loss	5	7	-	dB		
TX Output Spurious Levels				dBm/M- Hz	For power levels up to 18 dBm, OFDM @ 54 Mbps	
	2fo	-	-30			-25
	3fo	-	-37			-31
	4fo	-	-60	-50		
Output Spurious Levels Non Harmonics	-	-53	-	dBc	For power levels up to 18 dBm OFDM @ 54 Mbps	
Stability and Load Mismatch Susceptibility	-	-45	-	dBc	Unconditionally stable and no damage, 4:1 VSWR, up to P <sub>OUT</sub> = 18 dBm, OFDM 54 Mbps	
Settling Time	-	3	4	μs	Within 0.5 dB of final value	
I <sub>CC</sub> Quiescent Current	53	65	77	mA		
Shutdown Current	-	12	50	μA	V <sub>CC</sub> = 3.3 V, all other controls = 0 V	

Notes:

(1) EVM includes system noise floor of 1% (-40 dB).

**Table 5: Electrical Specification - Power Detector**  
 (T<sub>c</sub> = +25 °C, V<sub>CC</sub> = +3.3 V, PA<sub>ON</sub> = +1.8 V, V<sub>tx5</sub> = +1.8 V, OFDM Signal, 54 Mbps)

PARAMETER	MIN	TYP	MAX	UNIT	COMMENTS
Voltage Range	160 440	260 530	450 620	mV	P <sub>OUT</sub> = 0 dBm P <sub>OUT</sub> = 20 dBm
Total Internal Load Impedance	-	5	-	kΩ	
Dynamic Range	-	20	-	dB	
Resolution	-	13	-	mV/dB	
Video Bandwidth	-	5	-	MHz	Adjustable with External RC Load

**Table 6: Electrical Specification - 802.11a Receive Path**  
 (T<sub>c</sub> = +25 °C, V<sub>CC</sub> = +3.3 V, PA<sub>ON</sub> = 0 V, V<sub>rx5</sub> = +1.8 V, V<sub>tx5</sub> = 0 V)

PARAMETER	MIN	TYP	MAX	UNIT	COMMENTS
Operation Frequency	5150	-	5850	MHz	
Insertion Loss	-	2.7	3.5	dB	
Gain Flatness	-	+/-0.5	-	dB	Across full band
	-	+/-0.25	-	dB	Across any 40 MHz band
Input Return Loss	8	11	-	dB	50 Ω
Output Return Loss	12	16	-	dB	50 Ω
Port to Port Isolation	20	-	-	dB	5G ANT to 5G Tx, Switch in 5G Rx Mode
IIP3	-	40	-	dBm	
IP1dB	-	25	-	dBm	
Settling Time	-	0.5	1.0	μs	
Quiescent Current	-	0.8	-	mA	

**Table 7: Electrical Specifications - 802.11b/g TX**  
 (T<sub>c</sub> = +25 °C, V<sub>cc</sub> = +3.3 V, V<sub>tx2</sub> = +1.8 V, V<sub>rx2</sub> = V<sub>bt</sub> = 0 V)

PARAMETER	MIN	TYP	MAX	UNIT	COMMENTS
Operation Frequency	2412	-	2484	MHz	
Insertion Loss	-	1.0	1.5	dB	
Gain Flatness	-	+/-0.25	-	dB	Across any 40 MHz band
Input Return Loss	9	12	-	dB	50 Ω
Output Return Loss	7	10	-	dB	50 Ω
IIP3	-	39	-	dBm	
IP1dB	-	31	-	dBm	
Port to Port Isolation	20	-	-	dB	2G Tx to 2G Rx, Switch in 2G Tx Mode
Settling Time	-	0.5	1.0	μs	
Quiescent Current	-	1.3	-	mA	

**Table 8: Electrical Specifications - 802.11b/g RX**  
 (T<sub>c</sub> = +25 °C, V<sub>cc</sub> = +3.3 V, V<sub>rx2</sub> = +1.8 V, V<sub>bt</sub> = V<sub>tx2</sub> = 0 V)

PARAMETER	MIN	TYP	MAX	UNIT	COMMENTS
Operation Frequency	2412	-	2484	MHz	
Insertion Loss	-	1.6	2.4	dB	
Gain Flatness	-	+/-0.25	-	dB	Across any 40 MHz band
Input Return Loss	5	8	-	dB	50 Ω
Output Return Loss	6	10	-	dB	50 Ω
IIP3	-	33	-	dBm	
IP1dB	-	26	-	dBm	
Port to Port Isolation	20	-	-	dB	2G ANT to 2G Tx, Switch in 2G Rx Mode
Settling Time	-	0.5	1.0	μs	
Quiescent Current	-	1.1	-	mA	

**Table 9: Electrical Specifications - Bluetooth TX/RX**  
 (T<sub>c</sub> = +25 °C, V<sub>cc</sub> = +3.3 V, V<sub>bt</sub> = +1.8 V, V<sub>rx2</sub> = V<sub>tx2</sub> = 0 V)

PARAMETER	MIN	TYP	MAX	UNIT	COMMENTS
Operation Frequency	2402	-	2480	MHz	
Insertion Loss	-	1.6	2.4	dB	
Gain Flatness	-	+/-0.25	-	dB	Across any 40 MHz band
Input Return Loss	5	9	-	dB	50 Ω
Output Return Loss	7	12	-	dB	50 Ω
IIP3	-	34	-	dBm	
IP1dB	-	26	-	dBm	
Port to Port Isolation	20	-	-	dB	2G ANT to 2G Tx, Switch in 2G Rx Mode
Settling Time	-	0.5	1.0	μs	
Quiescent Current	-	1.1	-	mA	

**Table 10: Electrical Specifications - Switch and Control Pin**  
 (T<sub>c</sub> = +25 °C, V<sub>cc</sub> = +3.3 V, V<sub>CONTROL pin High</sub> = +1.8 V, V<sub>CONTROL pin Low</sub> = 0 V)

PARAMETER	MIN	TYP	MAX	UNIT	COMMENTS
Control Pin Steady State Input Current ( PA <sub>ON5</sub> )	- -	30 0.5	- -	μA	Logic Hi/On Logic Low/Off
Control Pin Steady State Input Current (V <sub>bt</sub> , V <sub>rx2</sub> , V <sub>tx2</sub> , V <sub>rx5</sub> , V <sub>tx5</sub> )	- -	30 0.5	- -	μA	Logic Hi/On Logic Low/Off
Control Pin Input Impedance	-	>10	-	kΩ	Logic Hi/On
TX - RX Isolation	20	-	-	dB	

Table 11: Switch Modes of Operation

MODES OF OPERATION	PA <sub>on</sub>	V <sub>bt</sub>	V <sub>rx2</sub>	V <sub>tx2</sub>	V <sub>rx5</sub>	V <sub>tx5</sub>
TX 2.4 GHz	LOW	LOW	LOW	<b>HIGH</b>	LOW	LOW
RX 2.4 GHz	LOW	LOW	<b>HIGH</b>	LOW	LOW	LOW
BT 2.4 GHz	LOW	<b>HIGH</b>	LOW	LOW	LOW	LOW
BT & RX 2.4 GHz	LOW	<b>HIGH</b>	<b>HIGH</b>	LOW	LOW	LOW
TX 5 GHz	<b>HIGH</b>	LOW	LOW	LOW	LOW	<b>HIGH</b>
Rx 5 GHz	LOW	LOW	LOW	LOW	<b>HIGH</b>	LOW
Power on Reset	LOW	LOW	LOW	LOW	LOW	LOW

V<sub>cc</sub> = +2.8 V to +4.8 V; Logic State LOW = 0 V to +0.5 V; Logic State HIGH = +1.4 V to +4.8 V

Performance Data Plots:

**Figure 3: Tx Path Gain vs. Output Power Across Frequency** ( $V_{cc} = +3.3\text{ V}$ ,  $Temp = 25\text{ }^{\circ}\text{C}$ , 802.11a, 54 Mbps OFDM)

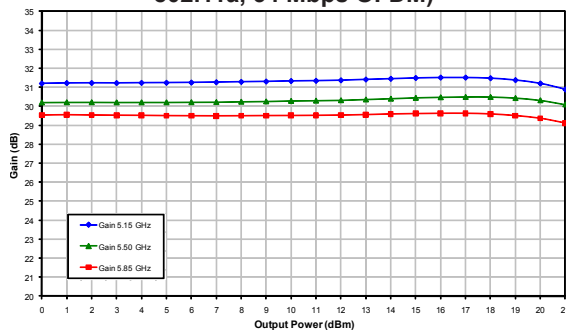

**Figure 4: Tx Path Gain vs. Output Power Across Voltage** (Freq = 5.5 GHz,  $Temp = 25\text{ }^{\circ}\text{C}$ , 802.11a, 54 Mbps OFDM)

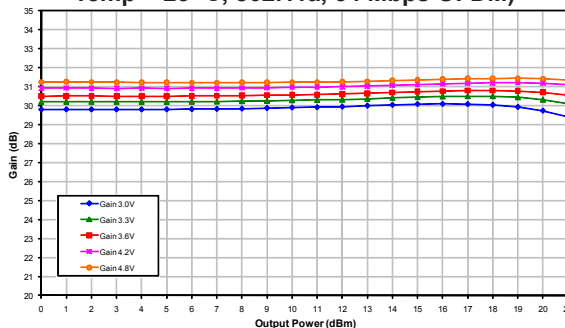

**Figure 5: Tx Path Gain vs. Output Power Across Temperature** (Freq = 5.5 GHz,  $V_{cc} = +3.3\text{ V}$ , 802.11a, 54 Mbps OFDM)

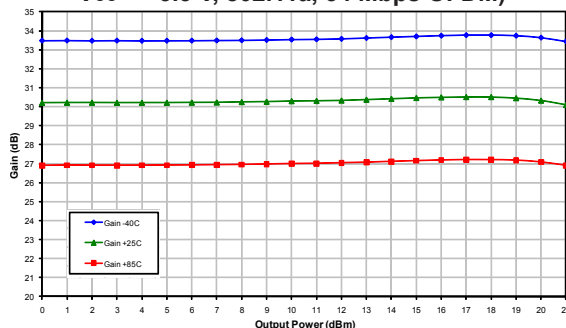

**Figure 6: Tx Path  $I_{cc}$  vs. Output Power Across Frequency** ( $V_{cc} = +3.3\text{ V}$ ,  $Temp = 25\text{ }^{\circ}\text{C}$ , 802.11a, 54 Mbps OFDM)

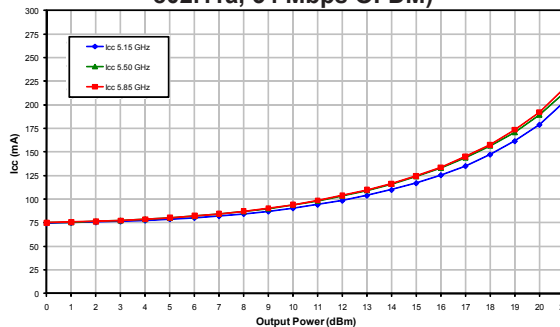

**Figure 7: Tx Path  $I_{cc}$  vs. Output Power Across Voltage** (Freq = 5.5 GHz,  $Temp = 25\text{ }^{\circ}\text{C}$ , 802.11a, 54 Mbps OFDM)

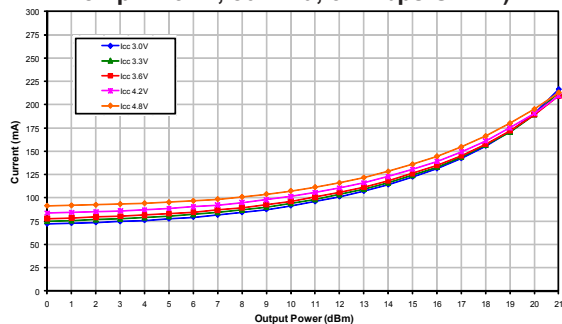

**Figure 8: Tx Path  $I_{cc}$  vs. Output Power Across Temperature** (Freq = 5.5 GHz,  $V_{cc} = +3.3\text{ V}$ , 802.11a, 54 Mbps OFDM)

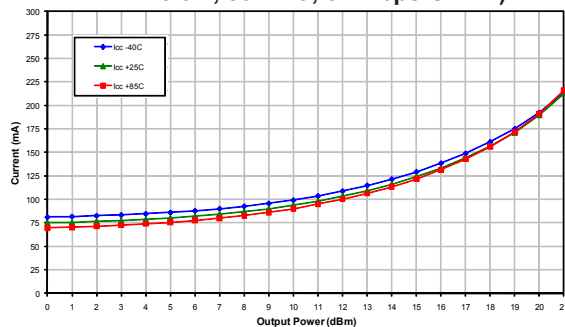

**Figure 9: Tx Path Dynamic EVM vs. Output Power Across Frequency ( $V_{CC} = +3.3\text{ V}$ ,  $Temp = 25\text{ }^{\circ}\text{C}$ , 802.11a, 54 Mbps OFDM)**

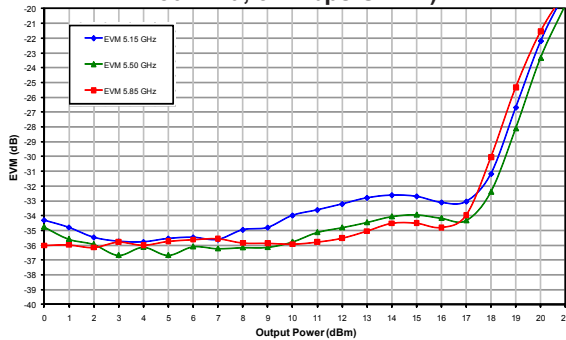

**Figure 10: Tx Path Dynamic EVM vs. Output Power Across Voltage (Freq = 5.5 GHz,  $Temp = 25\text{ }^{\circ}\text{C}$ , 802.11a, 54 Mbps OFDM)**

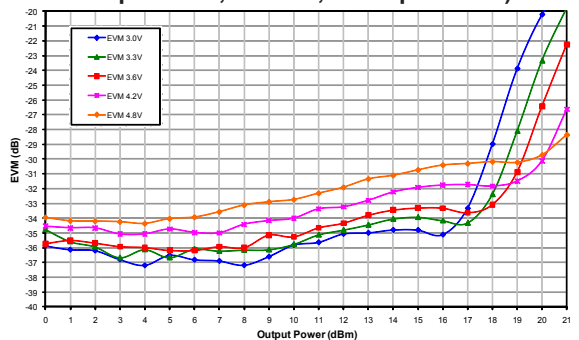

**Figure 11: Tx Path Dynamic EVM vs. Output Power Across Temperature (Freq = 5.5 GHz,  $V_{CC} = +3.3\text{ V}$ , 802.11a, 54 Mbps OFDM)**

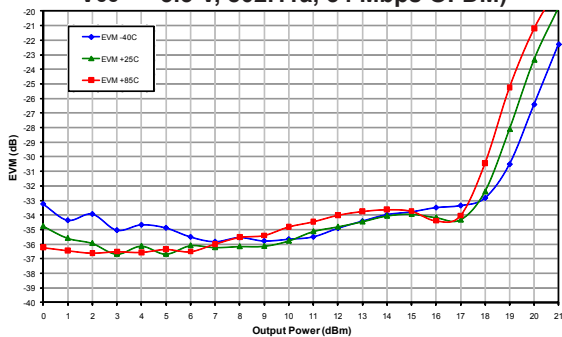

**Figure 12: Voltage Detector vs. Output Power Across Frequency ( $V_{CC} = +3.3\text{ V}$ ,  $Temp = 25\text{ }^{\circ}\text{C}$ , 802.11a, 54 Mbps OFDM)**

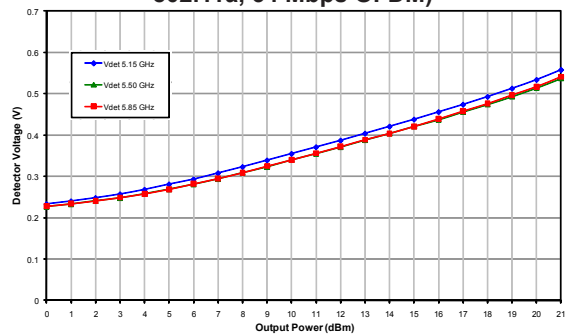

**Figure 13: Voltage Detector vs. Output Power Across Voltage (Freq = 5.5 GHz,  $Temp = 25\text{ }^{\circ}\text{C}$ , 802.11a, 54 Mbps OFDM)**

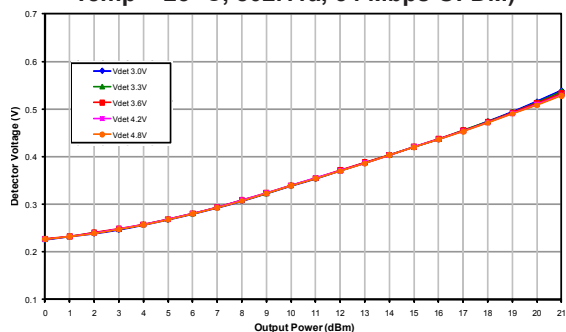

**Figure 14: Voltage Detector vs. Output Power Across Temperature (Freq = 5.5 GHz,  $V_{CC} = +3.3\text{ V}$ , 802.11a, 54 Mbps OFDM)**

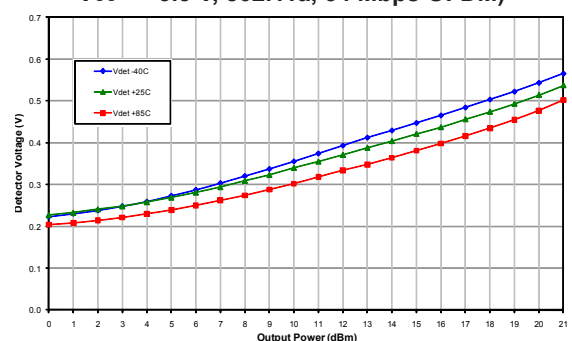

**Figure 15: 5 GHz Tx Path S21 Response**  
(V<sub>cc</sub> = +3.3 V, Temp = +25 °C)

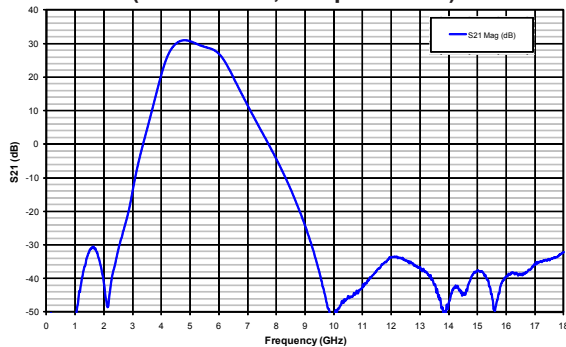

**Figure 16: 5 GHz Tx Path S11 & S22 Return Loss**  
(V<sub>cc</sub> = +3.3 V, Temp = +25 °C)

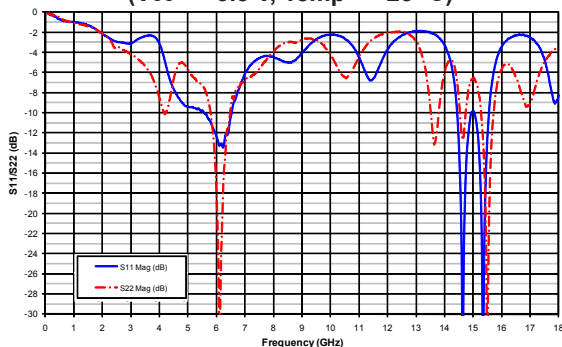

**Figure 17: 5 GHz Rx Path S21 Response**  
(V<sub>cc</sub> = +3.3 V, Temp = +25 °C)

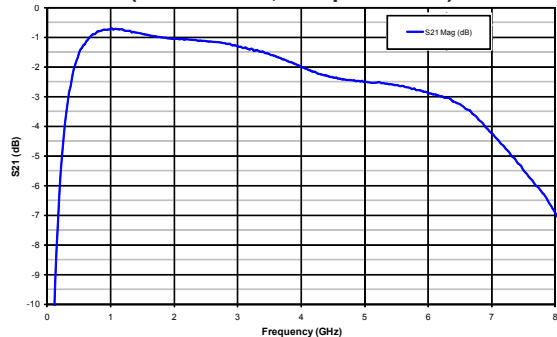

**Figure 18: 5 GHz Rx Path S11 & S22 Return Loss**  
(V<sub>cc</sub> = +3.3 V, Temp = +25 °C)

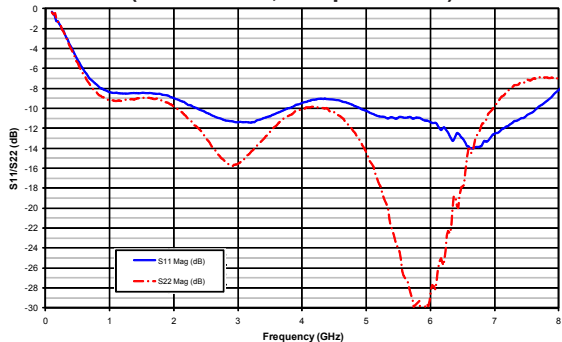

**Figure 19: 2 GHz Rx Path S21 Response**  
(V<sub>cc</sub> = +3.3 V, Temp = +25 °C)

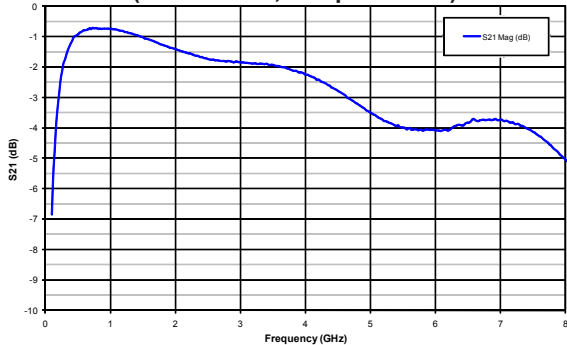

**Figure 20: 2 GHz Rx Path S11 & S22 Return Loss**  
(V<sub>cc</sub> = +3.3 V, Temp = +25 °C)

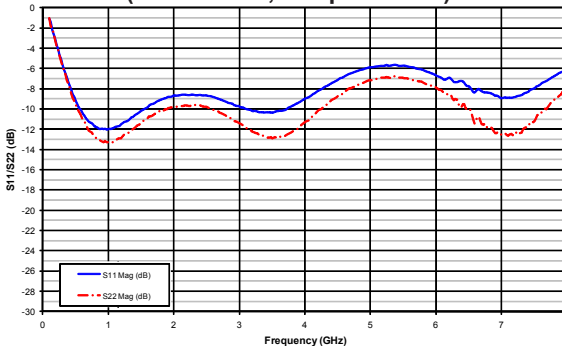

**Figure 21: 2 GHz Tx Path Response**  
(V<sub>CC</sub> = +3.3 V, Temp = +25 °C)

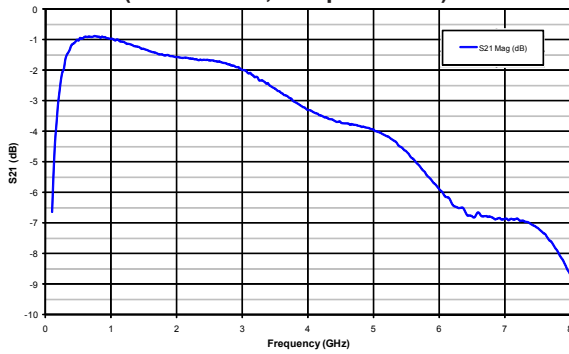

**Figure 22: 2 GHz Tx Path S11 & S22 Return Loss**  
(V<sub>CC</sub> = +3.3 V, Temp = +25 °C)

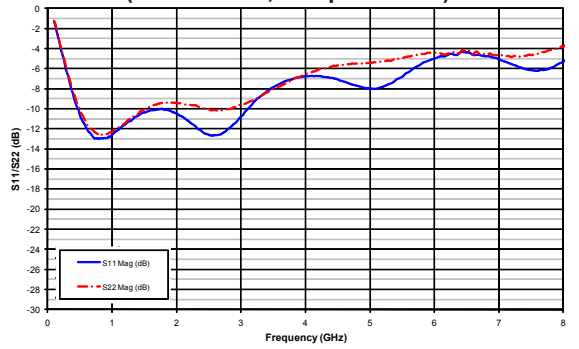

**Figure 23: Bluetooth Path S21 Response**  
(V<sub>CC</sub> = +3.3 V, Temp = +25 °C)

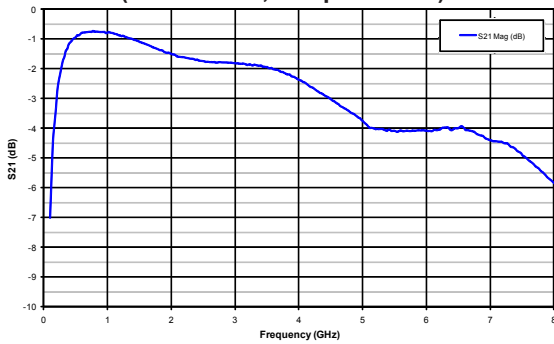

**Figure 24: Bluetooth Path S11 & S22 Return Loss**  
(V<sub>CC</sub> = +3.3 V, Temp = +25 °C)

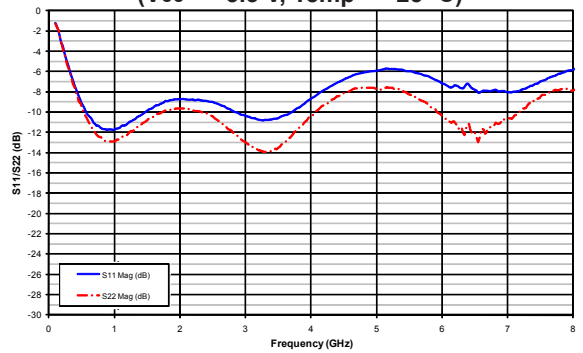

### APPLICATION INFORMATION

Although not shown in the schematic, a large value capacitor (~ 10 uF) should be connected to the voltage supply lines for low frequency decoupling.

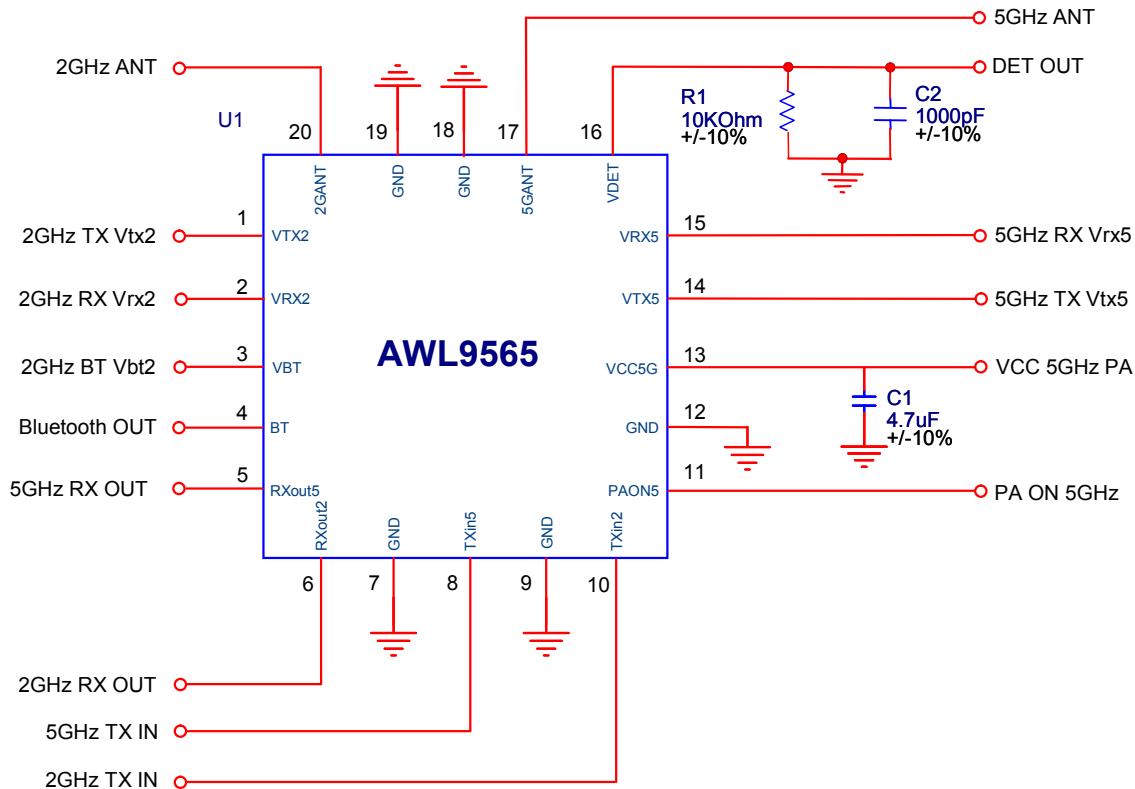
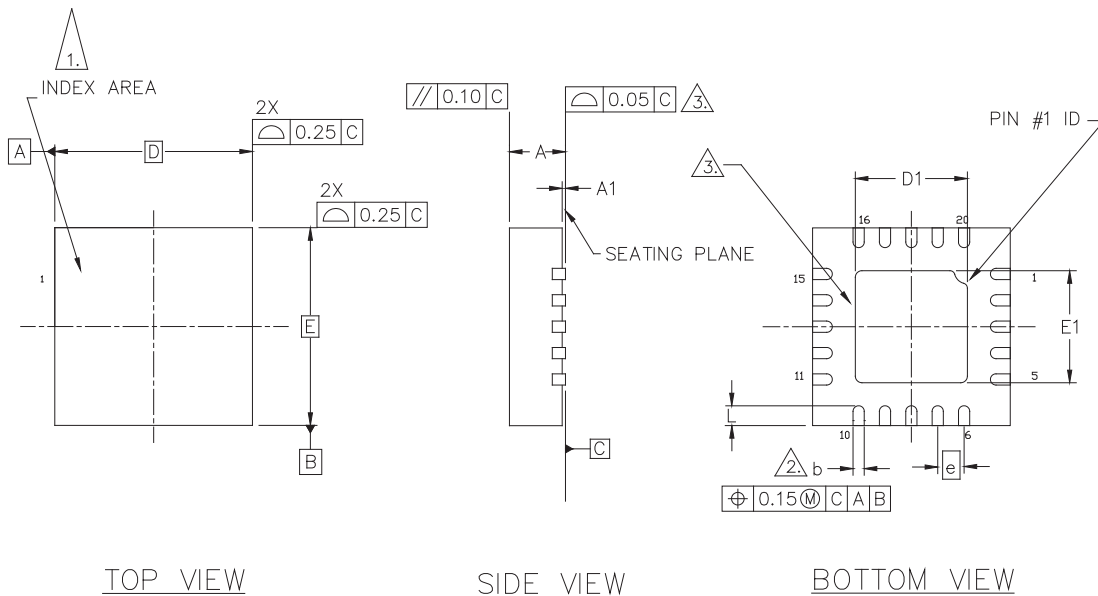

Figure 25: Application Circuit



SYMBOL	DIMENSIONS—MM			NOTE
	MIN.	NOM.	MAX.	
A	0.50	0.55	0.60	
A1	0.00	0.02	0.05	
b	0.15	0.20	0.25	
D	3.00 BSC			
D1	1.55	1.70	1.80	
E	3.00 BSC			
E1	1.55	1.70	1.80	
e	0.40 BSC			
L	0.20	0.30	0.40	

NOTES :

- 1. TERMINAL #1 IDENTIFIER AND PAD NUMBERING CONVENTION SHALL CONFORM TO JEDEC 95-1 SPP-012.
- 2. DIMENSION b APPLIES TO METALLIZED TERMINAL AND IS MEASURED BETWEEN 0.15 AND 0.30mm FROM TERMINAL TIP.
- 3. BILATERAL COPLANARITY ZONE APPLIES TO THE EXPOSED PAD AS WELL AS THE TERMINALS.

**Figure 26: Package Outline - 20 Pin, 3.0 x 3.0 x 0.55 mm QFN**

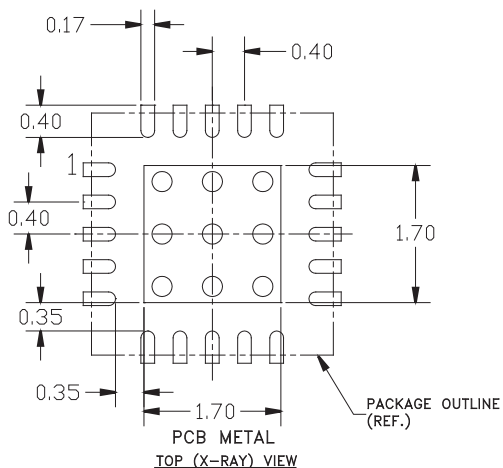

NOTES:

- (1) OUTLINE DRAWING REFERENCE:  
98001-TBD
- (2) UNLESS SPECIFIED DIMENSIONS  
ARE SYMMETRICAL ABOUT CENTER  
LINES SHOWN.
- (3) DIMENSIONS IN MILLIMETERS.
- (4) VIAS SHOWN IN PCB METAL VIEW  
ARE FOR REFERENCE ONLY.  
NUMBER & SIZE OF THERMAL VIAS  
REQUIRED DEPENDENT ON HEAT  
DISSIPATION REQUIREMENT AND THE  
PCB PROCESS CAPABILITY.
- (5) RECOMMENDED STENCIL THICKNESS:  
APPROX. 0.125mm (5 Mils)

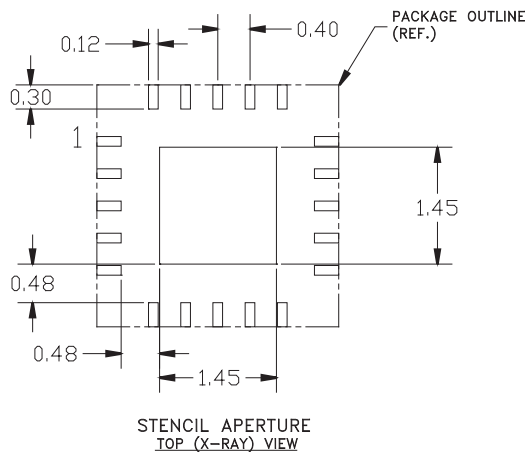
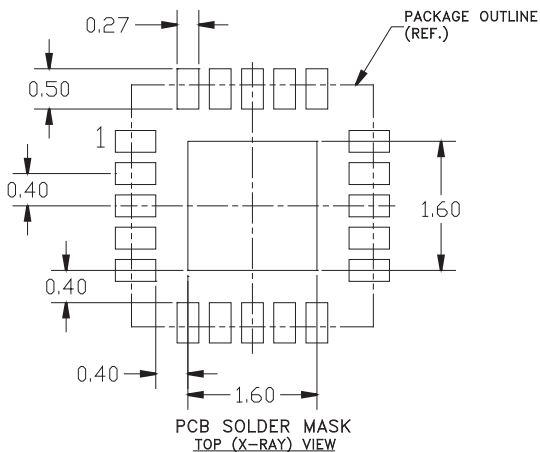

Figure 27: Recommended PCB Layout

**ORDERING INFORMATION**

ORDER NUMBER	TEMPERATURE RANGE	PACKAGE DESCRIPTION	COMPONENT PACKAGING
AWL9565HS41P7	-40 °C to +85 °C	20 pin, 3 x 3 x 0.55 mm Surface Mount Module	Bags
AWL9565HS41P9	-40 °C to +85 °C	20 pin, 3 x 3 x 0.55 mm Surface Mount Module	Partial Reel
AWL9565HS41Q7	-40 °C to +85 °C	20 pin, 3 x 3 x 0.55 mm Surface Mount Module	2500 piece T/R
EVA9565	-40 °C to +85 °C	Evaluation Board	Evaluation Board

**ANADIGICS, Inc.**

141 Mount Bethel Road  
Warren, New Jersey 07059, U.S.A.

Tel: +1 (908) 668-5000

Fax: +1 (908) 668-5132

URL: <http://www.anadigics.com>

**IMPORTANT NOTICE**

ANADIGICS, Inc. reserves the right to make changes to its products or to discontinue any product at any time without notice. The product specifications contained in Advanced Product Information sheets and Preliminary Data Sheets are subject to change prior to a product's formal introduction. Information in Data Sheets have been carefully checked and are assumed to be reliable; however, ANADIGICS assumes no responsibilities for inaccuracies. ANADIGICS strongly urges customers to verify that the information they are using is current before placing orders.

**WARNING**

ANADIGICS products are not intended for use in life support appliances, devices or systems. Use of an ANADIGICS product in any such application without written consent is prohibited.