

**FEATURES**

- InGaP HBT Technology
- High Efficiency: 38% CDMA
- Low Receive Band Noise (NRx) -134 dBm/Hz
- Small Foot Print (4 mm x 4 mm)
- 50  $\Omega$  Input and Output Matching
- Shut Down and Mode Control
- CDMA 2000 1XRTT Compliant
- $V_{REF} = +2.85 V$
- RoHS Compliant Package, 250 °C MSL-3

**APPLICATIONS**

- CDMA/EVDO 450 MHz Wireless Handsets and Data Devices

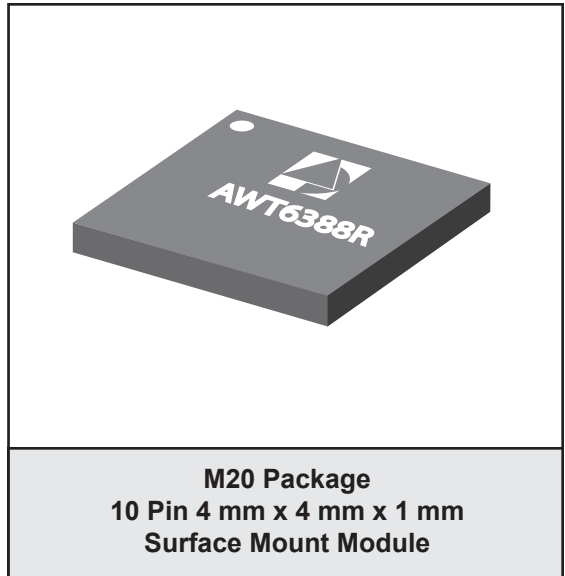

**PRODUCT DESCRIPTION**

The AWT6388R is a high power, high efficiency amplifier module for CDMA450 wireless applications. The device is manufactured on an advanced InGaP HBT MMIC technology offering state-of-the-art reliability, temperature stability and ruggedness. A low power quiescent current mode is digitally controlled to

reduce power drain on the system battery. The 4 mm x 4 mm x 1 mm laminate package is self contained, incorporating 50  $\Omega$  input and output matching networks optimized for output power, linearity, and efficiency.

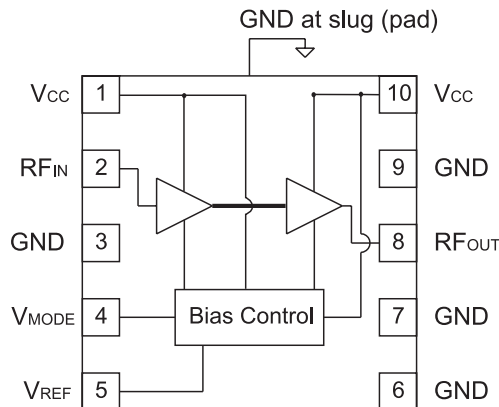

**Figure 1: Block Diagram**

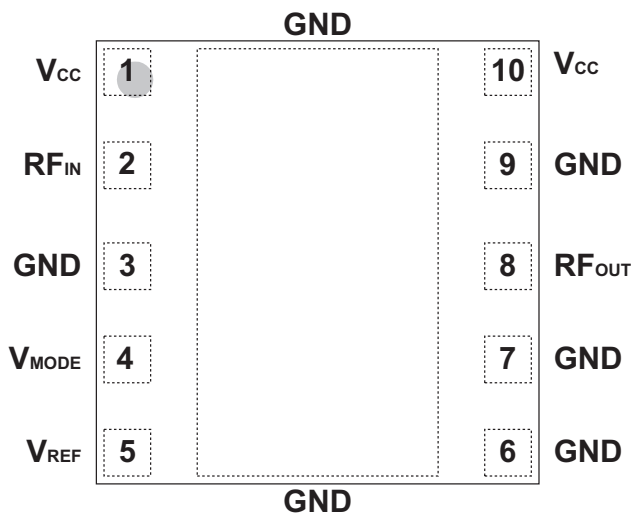

Figure 2: Pinout (X-ray Top View)

Table 1: Pin Description

PIN	NAME	DESCRIPTION
1	V <sub>CC</sub>	Supply Voltage
2	RF <sub>IN</sub>	RF Input
3	GND	Ground
4	V <sub>MODE</sub>	Mode Control Voltage
5	V <sub>REF</sub>	Reference Voltage
6	GND	Ground
7	GND	Ground
8	RF <sub>OUT</sub>	RF Output
9	GND	Ground
10	V <sub>CC</sub>	Supply Voltage

## ELECTRICAL CHARACTERISTICS

Table 2: Absolute Minimum and Maximum Ratings

PARAMETER	MIN	MAX	UNIT
Supply Voltage ( $V_{CC}$ )	0	+5	V
Mode Control Voltage ( $V_{MODE}$ )	0	+3.4	V
Reference Voltage ( $V_{REF}$ )	0	+3.4	V
RF Input Power ( $P_{IN}$ )	-	+10	dBm
Storage Temperature ( $T_{STG}$ )	-40	+150	°C

Stresses in excess of the absolute ratings may cause permanent damage. Functional operation is not implied under these conditions. Exposure to absolute ratings for extended periods of time may adversely affect reliability.

Table 3: Operating Ranges

PARAMETER	MIN	TYP	MAX	UNIT	COMMENTS
Operating Frequency (f)	450	-	460	MHz	
Supply Voltage ( $V_{CC}$ )	+3.2	+3.4	+4.2	V	
Reference Voltage ( $V_{REF}$ )	+2.75 0	+2.85 0	+2.95 +0.5	V	PA"on" PA"shut down"
Mode Control Voltage ( $V_{MODE}$ )	0 +2.5	0 +2.85	+0.5 +2.95	V	High Bias Mode Low Bias Mode
RF Output Power ( $P_{OUT}$ )	+29.0 <sup>(1)</sup>	+29.5	-	dBm	CDMA, $V_{CC}$ =+3.4V
Case Temperature ( $T_C$ )	-30	-	+90	°C	

The device may be operated safely over these conditions; however, parametric performance is guaranteed only over the conditions defined in the electrical specifications.

Notes:

(1) For operation at  $V_{CC}$  = +3.2 V ,  $P_{OUT}$  is derated by 0.5 dB.

**Table 4: Electrical Specifications – CDMA Operation (IS- 95 Modulation)**  
 (T<sub>C</sub> = +25 °C, V<sub>CC</sub> = +3.4 V, V<sub>REF</sub> = +2.85 V, 50 Ω system)

PARAMETER	MIN	TYP	MAX	UNIT	COMMENTS
Gain	24.5 23	27 25.5	30 28	dB	P <sub>OUT</sub> = +29.5 dBm, V <sub>MODE</sub> = 0 V P <sub>OUT</sub> = +16 dBm, V <sub>MODE</sub> = +2.85 V
Adjacent Channel Power at ± 885 kHz offset <sup>(1)</sup> Primary Channel BW = 1.23 MHz Adjacent Channel BW = 30 kHz	- -	-52 -52	-46.5 -47	dB	P <sub>OUT</sub> = +29.5 dBm, V <sub>MODE</sub> = 0 V P <sub>OUT</sub> = +16 dBm, V <sub>MODE</sub> = +2.85 V
Adjacent Channel Power at ± 1.98 MHz offset <sup>(1)</sup> Primary Channel BW = 1.23 MHz Adjacent Channel BW = 30 kHz	- -	-59 -68	-56.5 -57	dB	P <sub>OUT</sub> = +29.5 dBm, V <sub>MODE</sub> = 0 V P <sub>OUT</sub> = +16 dBm, V <sub>MODE</sub> = +2.85 V
Power-Added Efficiency <sup>(1), (2)</sup>	34 6	38 7	- -	%	P <sub>OUT</sub> = +29.5 dBm, V <sub>MODE</sub> = 0 V P <sub>OUT</sub> = +16 dBm, V <sub>MODE</sub> = +2.85 V
Quiescent Current (I <sub>q</sub> )	-	50	85	mA	through V <sub>CC</sub> pins, V <sub>MODE</sub> = +2.85 V
Reference Current	-	5	7	mA	through V <sub>REF</sub> pin, PA "on"
Mode Control Current	-	0.3	0.8	mA	through V <sub>MODE</sub> pin, (Low Bias Mode), V <sub>MODE</sub> = +2.85 V
Leakage Current	-	<1	5	μA	V <sub>CC</sub> = +4.3 V, V <sub>REF</sub> = 0 V, V <sub>MODE</sub> = 0 V
Noise in Receive Band	-	-134	-132	dBm/Hz	f <sub>o</sub> +10 MHz, P <sub>OUT</sub> ≤ +29.5 dBm
Harmonics 2f <sub>o</sub> 3f <sub>o</sub> , 4f <sub>o</sub>	- -	-39 -46	-30 -35	dBc	P <sub>OUT</sub> ≤ +29.5 dBm CW Measurement
Input Impedance	-	-	2.5:1	VSWR	
Spurious Output Level (all spurious outputs)	-	-	-70	dBc	P <sub>OUT</sub> ≤ +29.5 dBm In-band Load VSWR < 5:1 Out-of-band Load VSWR < 10:1 Applies over all operating ranges
Load mismatch stress with no permanent degradation or failure	10:1	-	-	VSWR	Applies over all operating ranges

**Notes:**

(1) P<sub>OUT</sub> is derated by 0.5 dB for CDMA 2000 operation.

(2) ACPR and Efficiency measured at 455 MHz.

## APPLICATION INFORMATION

To ensure proper performance, refer to all related Application Notes on the ANADIGICS web site: <http://www.anadigics.com>

### Shutdown Mode

The power amplifier may be placed in a shutdown mode by applying logic low levels (see Operating Ranges table) to both the  $V_{REF}$  and  $V_{MODE}$  voltages.

### Bias Modes

The power amplifier may be placed in either a Low Bias mode or a High Bias mode by applying the appropriate logic level (see Operating Ranges table) to the  $V_{MODE}$

voltage. The Bias Control table lists the recommended modes of operation for various applications.

High Bias Mode is recommended for  $P_{OUT}$  levels  $\geq 16$  dBm. At  $P_{OUT} < 16$  dBm. The PA should be “Mode Switched” to Low Bias Mode to improve efficiency and reduce current consumption at power output levels below 16 dBm.

Table 5: Bias Control

APPLICATION	$P_{OUT}$ LEVELS	BIAS MODE	$V_{REF}$	$V_{MODE}$	$V_{CC}$
CDMA - low power	$\leq +16$ dBm	Low	+2.85 V	+2.85 V	+3.2 - 4.2 V
CDMA - high power	$\geq +16$ dBm	High	+2.85 V	0 V	+3.2 - 4.2 V
Shutdown	-	Shutdown	0 V	0 V	+3.2 - 4.2 V

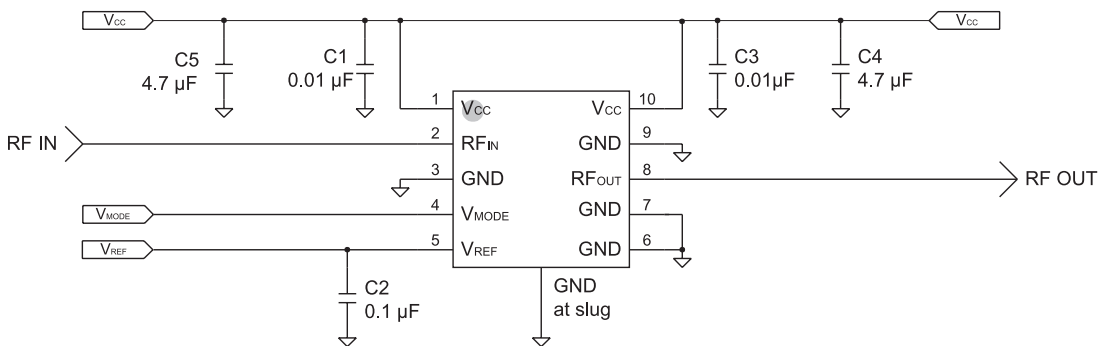
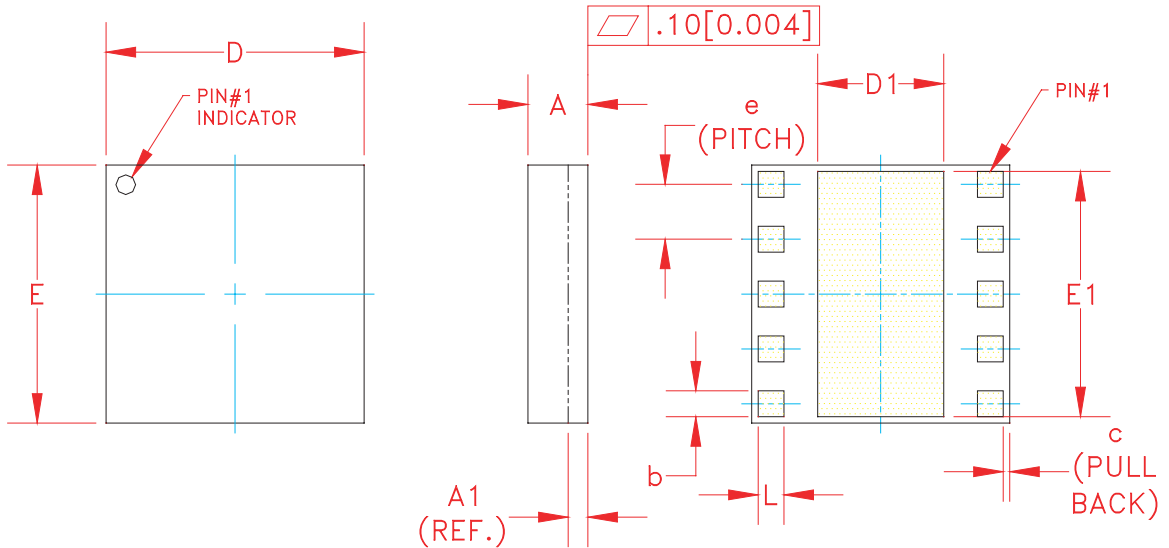

Figure 3: Application Circuit

PACKAGE OUTLINE



	MILLIMETERS			INCHES			NOTE
	MIN.	NOM.	MAX.	MIN.	NOM.	MAX.	
A	0.88	0.98	1.08	0.034	0.038	0.042	-
A1	0.32 (REF.)			0.0125 (REF.)			-
b	0.35	-	0.60	0.013	-	0.024	3
c	-	0.10	-	-	0.004	-	-
D	3.88	4.00	4.12	0.152	0.157	0.162	-
D1	1.90	-	2.25	0.075	-	0.088	-
E	3.88	4.00	4.12	0.152	0.157	0.162	-
E1	3.75	-	3.85	0.148	-	0.152	-
e	-	0.85	-	-	0.033	-	3
L	0.35	-	0.60	0.013	-	0.024	3

NOTES:

1. CONTROLLING DIMENSIONS: MILLIMETERS
2. UNLESS SPECIFIED TOLERANCE=±0.076[0.003].
3. PADS (INCLUDING CENTER) SHOWN UNIFORM SIZE FOR REFERENCE ONLY. ACTUAL PAD SIZE AND LOCATION WILL VARY WITHIN MIN. AND MAX. DIMENSIONS ACCORDING TO SPECIFIC LAMINATE DESIGN.

Figure 4: M20 Package Outline - 10 Pin 4 mm x 4 mm x 1 mm Surface Mount Module

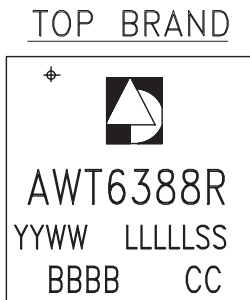

NOTES:

1. PIN 1 INDICATOR: LASER MARK
2. ANADIGICS LOGO SIZE: X=0.040±0.010 Y=0.048±0.010
3. TEXT : TYPE: ELITE  
SIZE : AS LARGE AS POSSIBLE
4. PART # AWT6388R = RoHS COMPLIANT
5. YEAR AND WORK WEEK: YYWW: YY = YEAR, WW = WORK WEEK
6. WAFER LOT NUMBER: LLLLLL = WAFER LOT#, (USE U3 LOT#)  
WAFER ID: SS = WAFER ID:
7. BOM NUMBER: BBBB
8. COUNTRY CODE: CC = TH -for- THAILAND, TW -for- TAIWAN,  
PH -for- PHILLIPPINES, CH -for- CHINA,  
ID -for- INDONESIA, HK -for- HONG KONG

Figure 5: Branding Specification

## COMPONENT PACKAGING

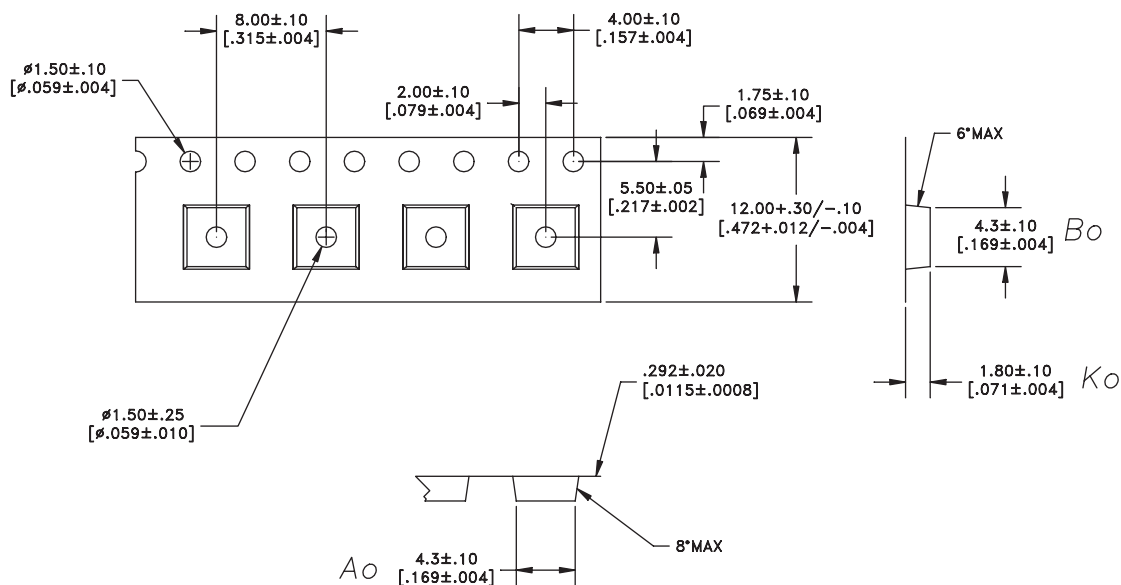

DIMENSIONS ARE IN MILLIMETERS [INCHES]  
STANDARD TOLERANCES

Figure 6: Tape & Reel Packaging

Table 5: Tape & Reel Dimensions

PACKAGE TYPE	TAPE WIDTH	POCKET PITCH	REEL CAPACITY	MAX REEL DIA
4 mm x 4 mm x 1 mm	12 mm	8 mm	2500	13"

## ORDERING INFORMATION

ORDER NUMBER	TEMPERATURE RANGE	PACKAGE DESCRIPTION	COMPONENT PACKAGING
AWT6388RM20P8	-30 °C to +90 °C	RoHS Compliant 10 Pin 4 mm x 4 mm x 1 mm Surface Mount Module	Tape and Reel, 2500 pieces per Reel
AWT6388RM20P9	-30 °C to +90 °C	RoHS Compliant 10 Pin 4 mm x 4 mm x 1 mm Surface Mount Module	Partial Tape and Reel

**ANADIGICS, Inc.**

141 Mount Bethel Road  
Warren, New Jersey 07059, U.S.A.

Tel: +1 (908) 668-5000

Fax: +1 (908) 668-5132

URL: <http://www.anadigics.com>

E-mail: [Mktg@anadigics.com](mailto:Mktg@anadigics.com)

**IMPORTANT NOTICE**

ANADIGICS, Inc. reserves the right to make changes to its products or to discontinue any product at any time without notice. The product specifications contained in Advanced Product Information sheets and Preliminary Data Sheets are subject to change prior to a product's formal introduction. Information in Data Sheets have been carefully checked and are assumed to be reliable; however, ANADIGICS assumes no responsibilities for inaccuracies. ANADIGICS strongly urges customers to verify that the information they are using is current before placing orders.

**WARNING**

ANADIGICS products are not intended for use in life support appliances, devices or systems. Use of an ANADIGICS product in any such application without written consent is prohibited.