

FEATURES

- InGaP HBT Technology
- High Efficiency:
 37 % @ +28 dBm output
- Zero Quiescent Current in Switch Mode
- Internal Voltage Regulation
- Optimized for a 50 Ω System
- Low Profile Surface Mount Package: 1 mm
- CDMA 1XRTT, 1xEV-DO Compliant
- RoHS-Compliant Package, 250 °C MSL-3

APPLICATIONS

- CDMA/EVDO PCS-band Wireless Handsets and Data Devices

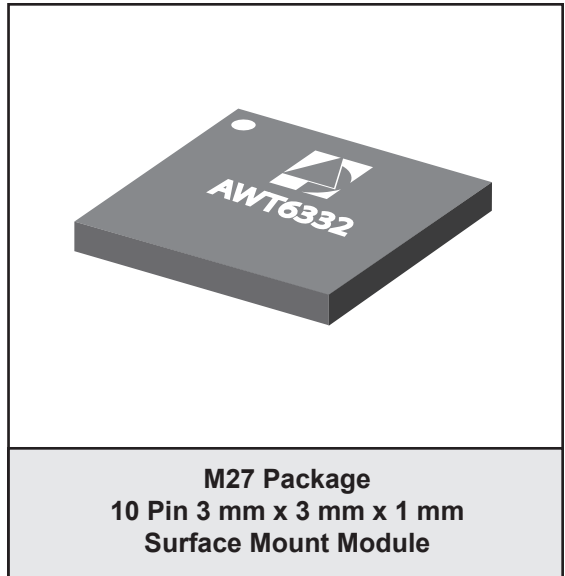

PRODUCT DESCRIPTION

The AWT6332 is a new product in the revolutionary ZeroIC™ PA family. The AWT6332 uses ANADIGICS' exclusive InGaP-Plus™ technology, which combines HBT and pHEMT devices on the same die, to enable state-of-the-art reliability, temperature stability, and ruggedness.

The AWT6332 has a unique architecture with two RF inputs. One input drives the power amplifier while the other input drives an RF switch that bypasses the power amplifier, going directly to the RF output. The mode control logic selects the PA or the RF switch. In

RF switch mode, current consumption is less than 10 μA, reducing the average current consumption 70% more than a HELP2™ PA over the CDG profile. Its integrated voltage regulator eliminates the need for external components further reducing size and BOM cost. The 3 mm x 3 mm x 1 mm surface mount package incorporates matching networks optimized for output power, efficiency, and linearity in a 50 Ω system.

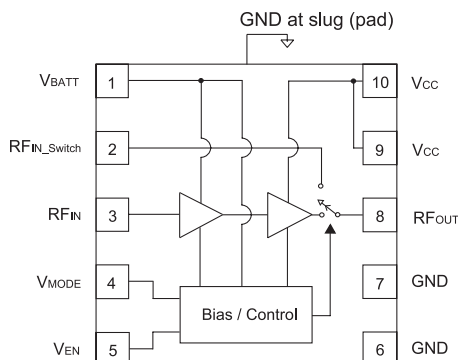

Figure 1: Block Diagram

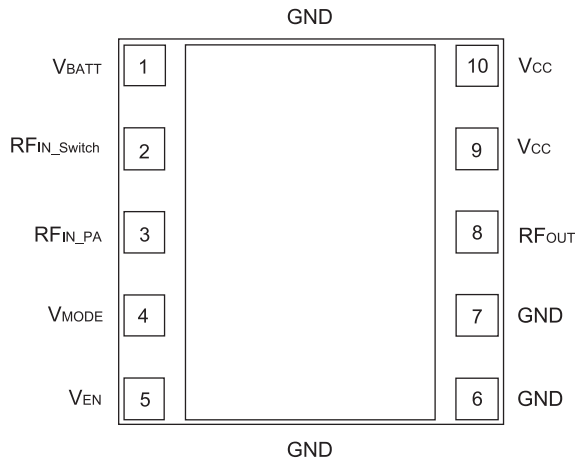

Figure 2: Pinout (X-ray Top View)

Table 1: Pin Description

PIN	NAME	DESCRIPTION
1	V _{BATT}	Battery Voltage
2	RF _{IN_SWITCH}	RF Input to Switch
3	RF _{IN_PA}	RF Input to PA
4	V _{MODE}	Mode Control Voltage
5	V _{EN}	PA Enable Voltage
6	GND	Ground
7	GND	Ground
8	RF _{OUT}	RF Output
9	V _{CC}	Supply Voltage
10	V _{CC}	Supply Voltage

ELECTRICAL CHARACTERISTICS

Table 2: Absolute Minimum and Maximum Ratings

PARAMETER	MIN	MAX	UNIT
Supply Voltage (V_{CC} and V_{BATT})	0	+5	V
Mode Control Voltage (V_{MODE})	0	+3.5	V
Enable Voltage (V_{EN})	0	+3.5	V
RF Input Power (P_{IN}) to PA	-	+10	dBm
RF Input Power (P_{IN}) to Switch	-	+20	dBm
Storage Temperature (T_{STG})	-40	+150	°C

Stresses in excess of the absolute ratings may cause permanent damage. Functional operation is not implied under these conditions. Exposure to absolute ratings for extended periods of time may adversely affect reliability.

Table 3: Operating Ranges

PARAMETER	MIN	TYP	MAX	UNIT	COMMENTS
Operating Frequency (f)	1850	-	1915	MHz	
Supply Voltage (V_{CC} and V_{BATT})	+3.2	+3.4	+4.2	V	
Enable Voltage (V_{EN})	+2.2 0	+2.4 -	+3.1 +0.5	V	PA "on", Switch "on" PA "shut down"
Mode Control Voltage (V_{MODE})	+2.2 0	+2.4 -	+3.1 +0.5	V	PA Mode Switch Mode
RF Output Power (P_{OUT})	27.5 ⁽¹⁾	+28.0	-	dBm	
Case Temperature (T_C)	-30	-	+85	°C	

The device may be operated safely over these conditions; however, parametric performance is guaranteed only over the conditions defined in the electrical specifications.

Notes:

(1) For operation at $V_{CC} = +3.2$ V, P_{OUT} is derated by 0.5 dB.

Table 4: Electrical Specifications - CDMA Operation (IS-95 Modulation)
(T_C = +25 °C, V_{BATT} = V_{CC} = +3.4 V, V_{EN} = +2.4 V, 50 Ω system)

PARAMETER	MIN	TYP	MAX	UNIT	COMMENTS
Gain Insertion Loss	24.5 -	27 0.8	29.5 1.5	dB	P _{OUT} = +28 dBm, V _{MODE} = +2.4 V V _{MODE} = 0 V
Adjacent Channel Power at +1.25 MHz offset Primary Channel BW - 1.23 MHz Adjacent Channel BW = 30 kHz	- -	-51 -70	-46.5 -	dBc	P _{OUT} = +28 dBm, V _{MODE} = +2.4 V V _{MODE} = 0 V
Adjacent Channel Power at +2.25 MHz offset Primary Channel BW - 1.23 MHz Adjacent Channel BW = 30 kHz	- -	-59.5 -70	-56.5 -	dBc	P _{OUT} = +28 dBm, V _{MODE} = +2.4 V V _{MODE} = 0 V
Isolation	31	34	-	dB	RF _{OUT} to RF _{IN_SWITCH} , V _{MODE} = +2.4 V, PA "on"
Power-Added Efficiency	34.5	37	-	%	P _{OUT} = +28 dBm, V _{MODE} = +2.4 V
Enable Current	-	<0.1	0.25	mA	through V _{EN} pin, V _{EN} = +2.4 V
Mode Control Current	-	<0.01	0.1	mA	through V _{MODE} pin, V _{MODE} = +2.4 V
Leakage Current	-	<10	15	μA	V _{CC} = +4.2 V, V _{EN} = 0 V, V _{MODE} = 0 V or +2.4 V
	-	<10	18		V _{CC} = +4.2 V, V _{EN} = +2.4 V, V _{MODE} = 0 V, Switch Mode
Noise in Receive Band	-	-136	-134	dBm/Hz	1930 MHz to 1990 MHz
Harmonics 2fo 3fo, 4fo	- -	-40 -45	-30 -30	dBc	CW Measurement
Input Impedance	-	-	2:1	VSWR	
Spurious Output Level (all spurious outputs)	-	-	-65	dBc	P _{OUT} ≤ +28 dBm In-band load VSWR < 5:1 Out-of-band load VSWR < 10:1 Applies over all operating ranges
Load mismatch stress with no permanent degradation or failure	8:1	-	-	VSWR	Applies over full operating range

Notes:

(1) PAE and ACP limit applies at 1880 MHz (IS-95 modulation).

APPLICATION INFORMATION

To ensure proper performance, refer to all related Application Notes on the ANADIGICS web site: <http://www.anadigics.com>

Shutdown Mode

The power amplifier may be placed in a shutdown mode by applying a logic low levels (see Operating Ranges table) to both the V_{EN} and V_{MODE} voltages.

Power Modes

The power amplifier may be placed in either a Low Power mode or a High Power mode by applying the appropriate logic level (see Operating Ranges table) to the V_{MODE} voltage. The Power Control table lists the recommended modes of operation for various applications.

Table 5: Power Control

APPLICATION	P_{OUT} LEVELS	POWER MODE	V_{EN}	V_{MODE}
CDMA - Switch Bypass	-*	Low	+2.4 V	0 V
Shutdown	-*	Low	0 V	+2.4 V
CDMA - PA	All	High	+2.4 V	+2.4 V
Shutdown	-	Shutdown	0 V	0 V

*Dependent upon typical output power of Transceiver and phone board design.

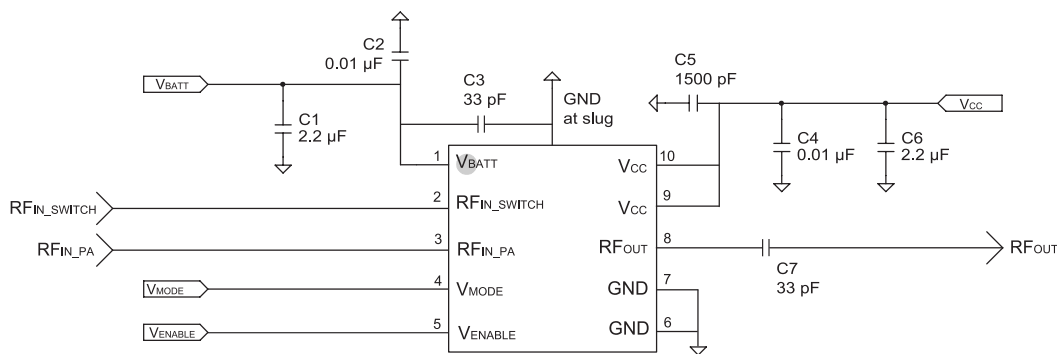
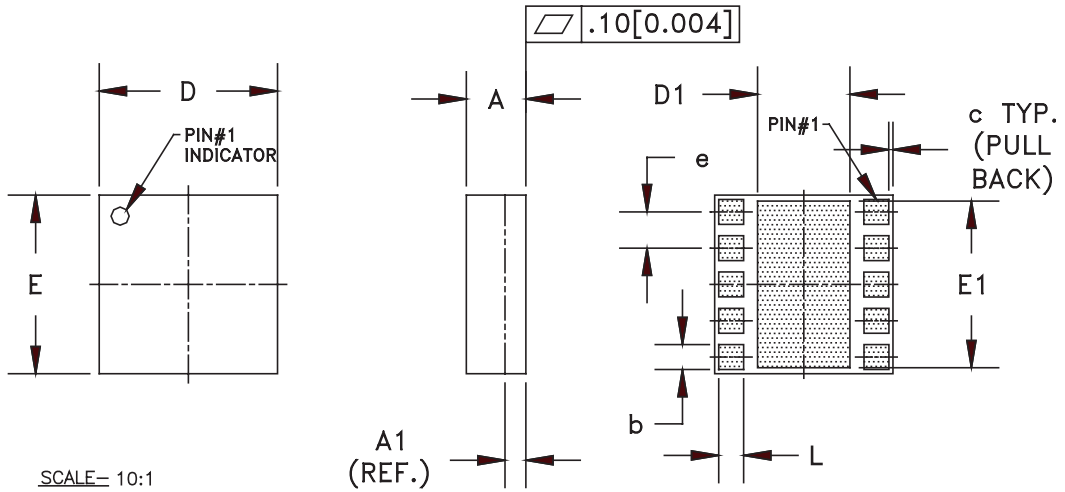

Figure 3: Application Circuit

PACKAGE OUTLINE



SCALE= 10:1

S _W B _{OL}	MILLIMETERS			INCHES			NOTE
	MIN.	NOM.	MAX.	MIN.	NOM.	MAX.	
A	0.91	1.01	1.11	0.035	0.039	0.043	-
A1	0.35 (REF.)			0.014 (REF.)			-
b	0.33	-	0.52	0.013	-	0.020	3
c	-	0.10	-	-	0.004	-	-
D	2.88	3.00	3.12	0.113	0.118	0.123	-
D1	1.57	-	1.82	0.062	-	0.072	3
E	2.88	3.00	3.12	0.113	0.118	0.123	-
E1	2.75	-	2.85	0.108	-	0.112	3
e	0.61			0.024			3
L	0.33	-	0.52	0.013	-	0.020	3

NOTES:

1. CONTROLLING DIMENSIONS: MILLIMETERS
2. UNLESS SPECIFIED TOLERANCE=±0.076[0.003].
3. PADS (INCLUDING CENTER) SHOWN UNIFORM SIZE FOR REFERENCE ONLY. ACTUAL PAD SIZE AND LOCATION WILL VARY WITHIN MIN. AND MAX. DIMENSIONS ACCORDING TO SPECIFIC LAMINATE DESIGN.
4. UNLESS SPECIFIED DIMENSIONS ARE SYMMETRICAL ABOUT CENTER LINES SHOWN.

Figure 4: M27 Package Outline - 10 Pin 3 mm x 3 mm x 1 mm Surface Mount Module

TOP BRAND



NOTES:

1. ANADIGICS LOGO SIZE: NONE
2. PART NUMBER: FOUR DIGIT NUMERICAL
3. WAFER LOT NUMBER: LLLL = LOT NUMBER
NN = WAFER I.D.
4. PIN 1 INDICATOR: LASER DOT
5. B.O.M. #: BBBB
6. COUNTRY CODE: CC = TH-for-THAILAND, TW-for-TAIWAN
CC = PH-for-PHILIPPINES, CH-for-CHINA
7. TYPE : ARIAL
SIZE : 1.5-POINT
COLOR : LASER

Figure 5: Branding Specification

COMPONENT PACKAGING

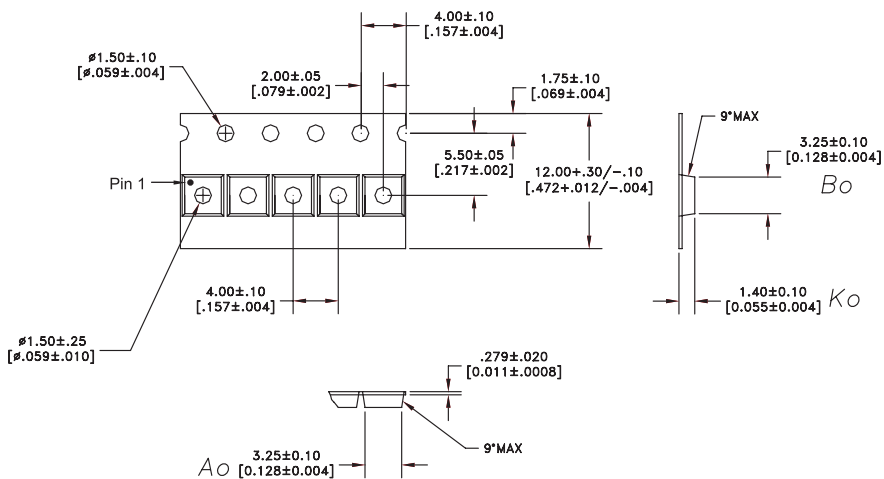

NOTES:

1. MATERIAL: 3000 (CARBON FILLED POLYCARBONATE)
100% RECYCLABLE.

DIMENSIONS ARE IN MILLIMETERS [INCHES]

DIMENSIONING AND TOLERANCING PER ASME Y14.5M-1994

Figure 6: Tape & Reel Packaging

Table 6: Tape & Reel Dimensions

PACKAGE TYPE	TAPE WIDTH	POCKET PITCH	REEL CAPACITY	MAX REEL DIA
3 mm x 3 mm x 1 mm	12 mm	4 mm	2500	7"

ORDERING INFORMATION

ORDER NUMBER	TEMPERATURE RANGE	PACKAGE DESCRIPTION	COMPONENT PACKAGING
AWT6332RM27Q7	-30 °C to +85 °C	RoHS-Compliant 10 Pin 3 mm x 3 mm x 1 mm Surface Mount Module	Tape and Reel, 2500 pieces per Reel
AWT6332RM27P9	-30 °C to +85 °C	RoHS-Compliant 10 Pin 3 mm x 3 mm x 1 mm Surface Mount Module	Partial Tape and Reel

**ANADIGICS, Inc.**

141 Mount Bethel Road
Warren, New Jersey 07059, U.S.A.

Tel: +1 (908) 668-5000

Fax: +1 (908) 668-5132

URL: <http://www.anadigics.com>

E-mail: Mktg@anadigics.com

IMPORTANT NOTICE

ANADIGICS, Inc. reserves the right to make changes to its products or to discontinue any product at any time without notice. The product specifications contained in Advanced Product Information sheets and Preliminary Data Sheets are subject to change prior to a product's formal introduction. Information in Data Sheets have been carefully checked and are assumed to be reliable; however, ANADIGICS assumes no responsibilities for inaccuracies. ANADIGICS strongly urges customers to verify that the information they are using is current before placing orders.

WARNING

ANADIGICS products are not intended for use in life support appliances, devices or systems. Use of an ANADIGICS product in any such application without written consent is prohibited.