

### FEATURES

- InGaP HBT Technology
- High Efficiency:
  - 42% @ P<sub>OUT</sub> = +28.5 dBm
  - 20% @ P<sub>OUT</sub> = +16 dBm
  - 9% @ P<sub>OUT</sub> = +8 dBm
- Low Quiescent Current: 8 mA
- Low Leakage Current in Shutdown Mode: <1 μA
- Internal Voltage Regulator Eliminates the need for External Reference Voltage (No V<sub>REF</sub> Required)
- Optimized for a 50 Ω System
- Low Profile Miniature Surface Mount Package
- RoHS Compliant Package, 250 °C MSL-3
- HSPA Compliant (no backoff)

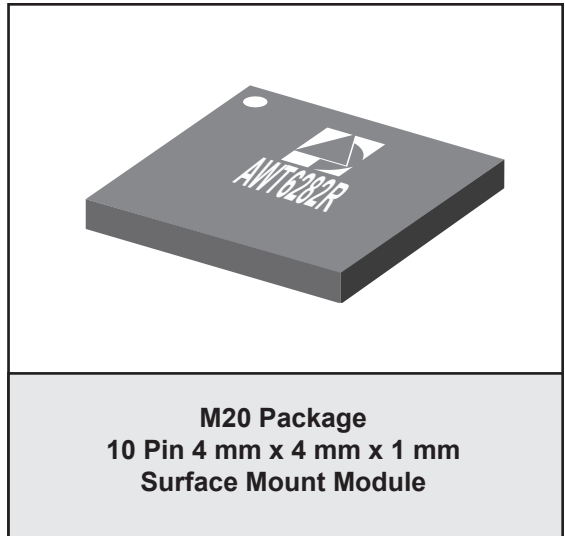

### APPLICATIONS

- WCDMA/HSPA AWS Band Wireless Handsets and Data Devices

### PRODUCT DESCRIPTION

The AWT6282 HELP3™ PA is the 3rd generation WCDMA product for UMTS handsets. This PA incorporates ANADIGICS' HELP3™ technology to provide low power consumption without the need for an external voltage regulator. The device is manufactured on an advanced InGaP HBT MMIC technology offering state-of-the-art reliability, temperature stability, and

ruggedness. There are three selectable bias modes that optimize efficiency for different output power levels, and a shutdown mode with low leakage current, increase handset talk and standby time. The self-contained 4 mm x 4 mm x 1 mm surface mount package incorporates matching networks optimized for output power, efficiency, and linearity in a 50 Ω system.

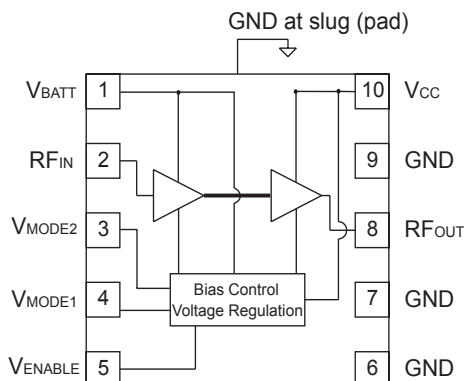

**Figure 1: Block Diagram**

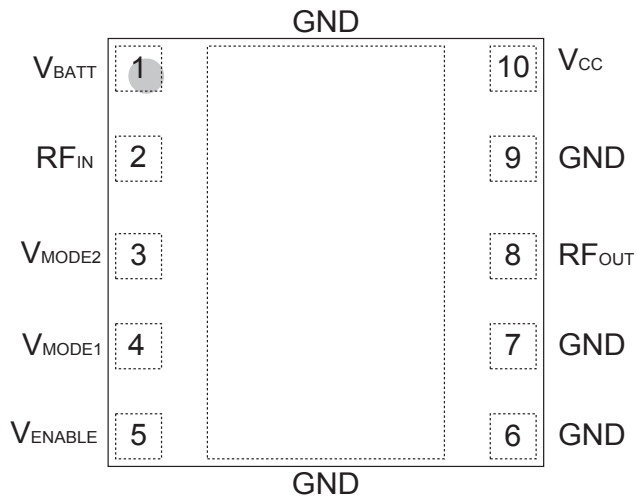

**Figure 2: Pinout (X-ray Top View)**

**Table 1: Pin Description**

PIN	NAME	DESCRIPTION
1	$V_{BATT}$	Battery Voltage
2	$RF_{IN}$	RF Input
3	$V_{MODE2}$	Mode Control Voltage 2
4	$V_{MODE1}$	Mode Control Voltage 1
5	$V_{ENABLE}$	PA Enable Voltage
6	GND	Ground
7	GND	Ground
8	$RF_{OUT}$	RF Output
9	GND	Ground
10	$V_{CC}$	Supply Voltage

## ELECTRICAL CHARACTERISTICS

Table 2: Absolute Minimum and Maximum Ratings

PARAMETER	MIN	MAX	UNIT
Supply Voltage ( $V_{CC}$ )	0	+5	V
Battery Voltage ( $V_{BATT}$ )	0	+6	V
Control Voltages ( $V_{MODE1}$ , $V_{MODE2}$ , $V_{ENABLE}$ )	0	+3.5	V
RF Input Power ( $P_{IN}$ )	-	+10	dBm
Storage Temperature ( $T_{STG}$ )	-40	+150	°C

Stresses in excess of the absolute ratings may cause permanent damage. Functional operation is not implied under these conditions. Exposure to absolute ratings for extended periods of time may adversely affect reliability.

Table 3: Operating Ranges

PARAMETER	MIN	TYP	MAX	UNIT	COMMENTS
Operating Frequency (f)	1710	-	1785	MHz	
Supply Voltage ( $V_{CC}$ )	+3.2	+3.4	+4.2	V	$P_{OUT} \leq +28.5$ dBm
Enable Voltage ( $V_{ENABLE}$ )	+2.15 0	+2.4 -	+3.1 +0.5	V	PA "on" PA "shut down"
Mode Control Voltage ( $V_{MODE1}$ , $V_{MODE2}$ )	+2.15 0	+2.4 -	+3.1 +0.5	V	Low Bias Mode High Bias Mode
RF Output Power ( $P_{OUT}$ ) R99 WCDMA, HPM HSPA (MPR=0), HPM R99 WCDMA, LPM HSPA (MPR=0), LPM	28 <sup>(1)</sup> 27 <sup>(1)</sup> 15.5 <sup>(1)</sup> 14.5 <sup>(1)</sup>	28.5 27.5 16 15	28.5 27.5 16 15	dBm	3GPP TS 34.121-1, Rel 7 Table C.11.1.3
Case Temperature ( $T_C$ )	-30	-	+90	°C	

The device may be operated safely over these conditions; however, parametric performance is guaranteed only over the conditions defined in the electrical specifications.

## Notes:

(1) For operation at  $V_{CC} = +3.2$  V,  $P_{OUT}$  is derated by 0.5 dB.

Table 4: Electrical Specifications

(Unless Otherwise Specified:  $T_C = +25\text{ }^\circ\text{C}$ ,  $V_{CC} = +3.4\text{ V}$ ,  $V_{BATT} = +3.4\text{ V}$ ,  $V_{ENABLE} = +2.4\text{ V}$ ,  $50\text{ }\Omega$  system)

PARAMETER	MIN	TYP	MAX	UNIT	COMMENTS		
					P <sub>OUT</sub>	V <sub>MODE1</sub>	V <sub>MODE2</sub>
Gain	25.0 13.0 11.0	27.5 15.0 14.0	30.0 17.5 16.0	dB	+28.5 dBm +16 dBm +8 dBm	0 V 2.4 V 2.4 V	0 V 0 V 2.4 V
ACLR1 at 5 MHz offset <sup>(1)</sup>	- - -	-41 -45 -44	-38 -38 -38	dBc	+28.5 dBm +16 dBm +8 dBm	0 V 2.4 V 2.4 V	0 V 0 V 2.4 V
ACLR2 at 10 MHz offset	- - -	-56 -55 -57	-48 -48 -48	dBc	+28.5 dBm +16 dBm +8 dBm	0 V 2.4 V 2.4 V	0 V 0 V 2.4 V
Power-Added Efficiency <sup>(1)</sup>	39 17 7	42 20 9	- - -	%	+28.5 dBm +16 dBm +8 dBm	0 V 2.4 V 2.4 V	0 V 0 V 2.4 V
Quiescent Current (I <sub>q</sub> ) Low Bias Mode Medium Bias Mode	- - -	8 15	12 22	mA	V <sub>MODE1</sub> = +2.4 V, V <sub>MODE2</sub> = +2.4 V V <sub>MODE1</sub> = +2.4 V, V <sub>MODE2</sub> = 0 V		
Mode Control Current	-	0.25	0.8	mA	through V <sub>MODE</sub> pins, V <sub>MODE</sub> = +2.4 V		
Enable Current	-	0.2	0.8	mA	through V <sub>ENABLE</sub> pin, V <sub>EN</sub> = +2.4 V		
BATT Current	-	3.5	5	mA	through V <sub>BATT</sub> pin, V <sub>MODE1</sub> = +2.4 V, V <sub>MODE2</sub> = +2.4 V or 0 V		
Leakage Current	-	<1	5	μA	V <sub>BATT</sub> = +4.2 V, V <sub>CC</sub> = +4.2 V, V <sub>ENABLE</sub> = 0 V, V <sub>MODE1</sub> = 0 V, V <sub>MODE2</sub> = 0 V		
Noise in Receive Band	- -	-136 -140	-135 -138	dBm/Hz	1845 MHz to 1880 MHz 2110 MHz to 2155 MHz		
Harmonics 2fo 3fo, 4fo	- -	-41 -52	-35 -35	dBc	P <sub>OUT</sub> ≤ +28.5 dBm		
Input Impedance	-	-	2:1	VSWR			
Spurious Output Level (all spurious outputs)	-	-	-70	dBc	P <sub>OUT</sub> ≤ +28.5 dBm In-band load VSWR < 5:1 Out-of-band load VSWR < 10:1 Applies over all operating conditions		
Load mismatch stress with no permanent degradation or failure	8:1	-	-	VSWR	Applies over full operating range		

Notes:

(1) ACLR and Efficiency measured at 1747.5 MHz.

## APPLICATION INFORMATION

To ensure proper performance, refer to all related Application Notes on the ANADIGICS web site: <http://www.anadigics.com>

### Shutdown Mode

The power amplifier may be placed in a shutdown mode by applying logic low levels (see Operating Ranges table) to the  $V_{ENABLE}$ ,  $V_{MODE1}$  and  $V_{MODE2}$  voltages.

### Bias Modes

The power amplifier may be placed in either a Low Bias mode or a High Bias mode by applying the appropriate

logic level (see Operating Ranges table) to the  $V_{MODE}$  voltages. The Bias Control table lists the recommended modes of operation for various applications.

Three operating modes are recommended to optimize current consumption. High Bias/High Power operating mode is for  $P_{OUT}$  levels  $\geq 16$  dBm. At  $\sim 16$  dBm - 7 dBm, the PA should be "Mode Switched" to Medium Power/Medium Bias Mode. For  $P_{OUT}$  levels  $\leq -8$  dBm, the PA can be switched to Low Power/Low Bias Mode for even lower quiescent current consumption.

Table 5: Bias Control

APPLICATION	$P_{OUT}$ LEVELS	BIAS MODE	$V_{ENABLE}$	$V_{MODE1}$	$V_{MODE2}$	$V_{CC}$	$V_{BATT}$
WCDMA - low power (Low Bias Mode)	$\leq +8$ dBm	Low	+2.4 V	+2.4 V	+2.4 V	3.2 - 4.2 V	$\geq 3.2$ V
WCDMA - med power (Med Bias Mode)	$7 P_{OUT} \leq +16$ dBm	Low	+2.4 V	+2.4 V	0 V	3.2 - 4.2 V	$\geq 3.2$ V
WCDMA - high power (High Bias Mode)	$> +16$ dBm	High	+2.4 V	0 V	0 V	3.2 - 4.2 V	$\geq 3.2$ V
Optional lower $V_{CC}$ in low power low bias mode	$\leq +7$ dBm	Low	+2.4 V	+2.4 V	2.4 V	1.5 V	$\geq 3.2$ V
Shutdown	-	Shutdown	0 V	0 V	0 V	3.2 - 4.2 V	$\geq 3.2$ V

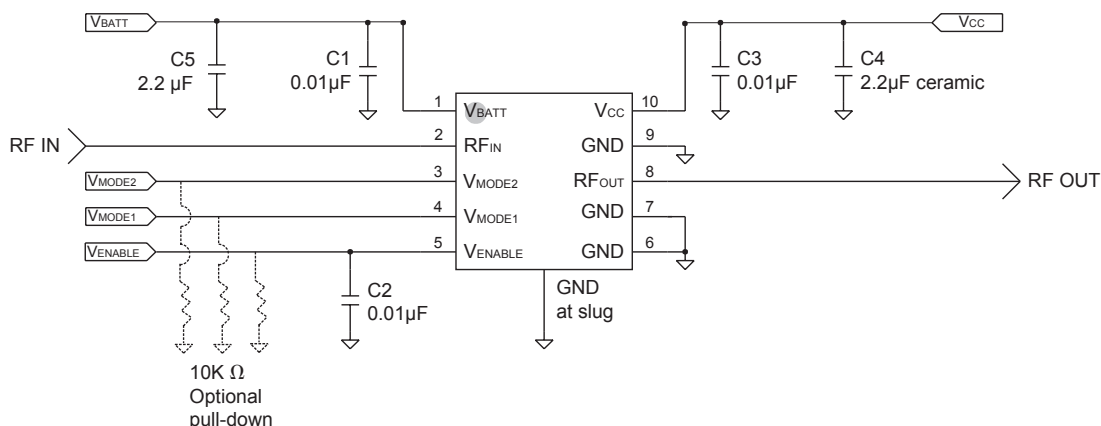
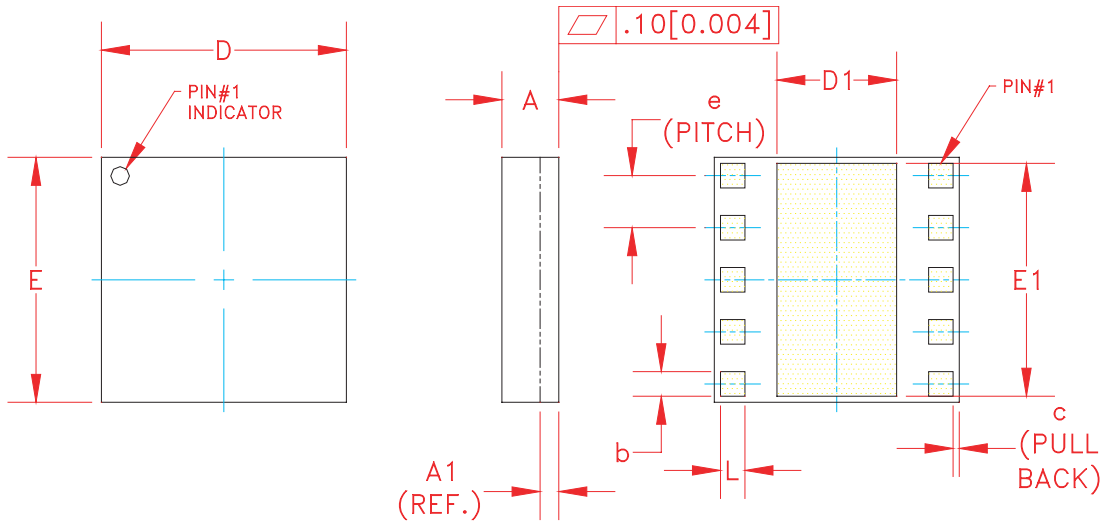

Figure 3: Application Circuit Schematic

PACKAGE OUTLINE



	MILLIMETERS			INCHES			NOTE
	MIN.	NOM.	MAX.	MIN.	NOM.	MAX.	
A	0.88	0.98	1.08	0.034	0.038	0.042	-
A1	0.32 (REF.)			0.0125 (REF.)			-
b	0.35	-	0.60	0.013	-	0.024	3
c	-	0.10	-	-	0.004	-	-
D	3.88	4.00	4.12	0.152	0.157	0.162	-
D1	1.90	-	2.25	0.075	-	0.088	-
E	3.88	4.00	4.12	0.152	0.157	0.162	-
E1	3.75	-	3.85	0.148	-	0.152	-
e	-	0.85	-	-	0.033	-	3
L	0.35	-	0.60	0.013	-	0.024	3

NOTES:

1. CONTROLLING DIMENSIONS: MILLIMETERS
2. UNLESS SPECIFIED TOLERANCE= $\pm 0.076 [0.003]$ .
3. PADS (INCLUDING CENTER) SHOWN UNIFORM SIZE FOR REFERENCE ONLY. ACTUAL PAD SIZE AND LOCATION WILL VARY WITHIN MIN. AND MAX. DIMENSIONS ACCORDING TO SPECIFIC LAMINATE DESIGN.

Figure 4: M20 Package Outline - 10 Pin 4 mm x 4 mm x 1 mm Surface Mount Module

TOP BRAND

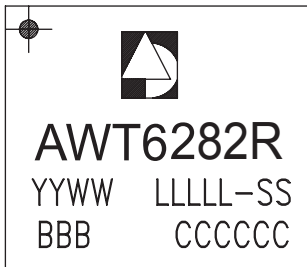

NOTES:

1. ANADIGICS LOGO SIZE: X=0.040 $\pm$ 0.010 Y=0.048 $\pm$ 0.010
2. PART # AWT6282R
3. YEAR AND WORK WEEK: YYWW: YY = YEAR, WW = WORK WEEK
4. LOT - WAFER I.D.: LLLLL - SS = WAFER/LOT I.D.
5. PIN 1 INDICATOR: MOLD NOTCH -or- INK DOT
6. BOM # BBB
7. COUNTRY CODE: CCCCC
8. TYPE : ELITE  
SIZE : AS LARGE AS POSSIBLE  
LASER MARKED

Figure 5: Branding Specification - M20 Package

COMPONENT PACKAGING

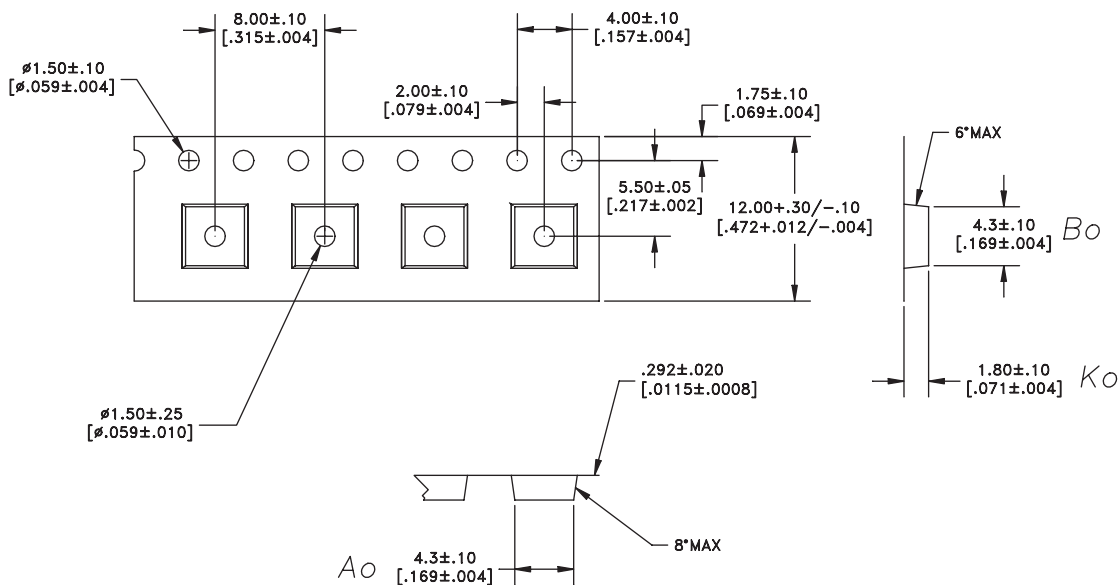

DIMENSIONS ARE IN MILLIMETERS [INCHES]  
STANDARD TOLERANCES

Figure 6: Tape & Reel Packaging

Table 6: Tape & Reel Dimensions

PACKAGE TYPE	TAPE WIDTH	POCKET PITCH	REEL CAPACITY	MAX REEL DIA
4 mm x 4 mm x 1 mm	12 mm	8 mm	2500	13"

## ORDERING INFORMATION

ORDER NUMBER	TEMPERATURE RANGE	PACKAGE DESCRIPTION	COMPONENT PACKAGING
AWT6282RM20P8	-30 °C to +90 °C	RoHS Compliant 10 Pin 4 mm x 4 mm x 1 mm Surface Mount Module	Tape and Reel, 2500 pieces per Reel
AWT6282RM20P9	-30 °C to +90 °C	RoHS Compliant 10 Pin 4 mm x 4 mm x 1 mm Surface Mount Module	Partial Tape and Reel

**ANADIGICS, Inc.**

141 Mount Bethel Road  
Warren, New Jersey 07059, U.S.A.

Tel: +1 (908) 668-5000

Fax: +1 (908) 668-5132

URL: <http://www.anadigics.com>

E-mail: [Mktg@anadigics.com](mailto:Mktg@anadigics.com)

**IMPORTANT NOTICE**

ANADIGICS, Inc. reserves the right to make changes to its products or to discontinue any product at any time without notice. The product specifications contained in Advanced Product Information sheets and Preliminary Data Sheets are subject to change prior to a product's formal introduction. Information in Data Sheets have been carefully checked and are assumed to be reliable; however, ANADIGICS assumes no responsibilities for inaccuracies. ANADIGICS strongly urges customers to verify that the information they are using is current before placing orders.

**WARNING**

ANADIGICS products are not intended for use in life support appliances, devices or systems. Use of an ANADIGICS product in any such application without written consent is prohibited.