

FEATURES

- InGaP HBT Technology
- High Efficiency:
 - 42 % @ P_{OUT} = +29 dBm
 - 21 % @ P_{OUT} = +16 dBm
 - 8.5 % @ P_{OUT} = +8 dBm
 - (without DC/DC Converter)
- Low Quiescent Current: 7 mA
- Low Leakage Current in Shutdown Mode: <1 μA
- Internal Voltage Regulator Eliminates the Need for External Reference Voltage (No V_{REF} Required)
- Optimized for a 50 Ω System
- Low Profile Miniature Surface Mount Package
- RoHS Compliant Package, 250 °C MSL-3
- HSPA Compliant (no backoff)

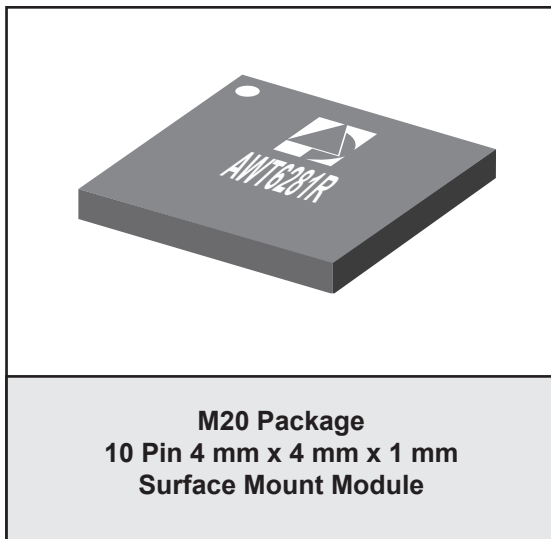

APPLICATIONS

- WCDMA/HSPA 900 MHz Band Wireless Handsets and Data Devices

PRODUCT DESCRIPTION

The AWT6281 HELP3™ PA is the 3rd generation WCDMA product for UMTS handsets. This PA incorporates ANADIGICS' HELP3™ technology to provide low power consumption without the need for an external voltage regulator. The device is manufactured on an advanced InGaP HBT MMIC technology offering state-of-the-art reliability, temperature stability, and

ruggedness. There are three selectable bias modes that optimize efficiency for different output power levels, and a shutdown mode with low leakage current, increase handset talk and standby time. The self-contained 4 mm x 4 mm x 1 mm surface mount package incorporates matching networks optimized for output power, efficiency, and linearity in a 50 Ω system.

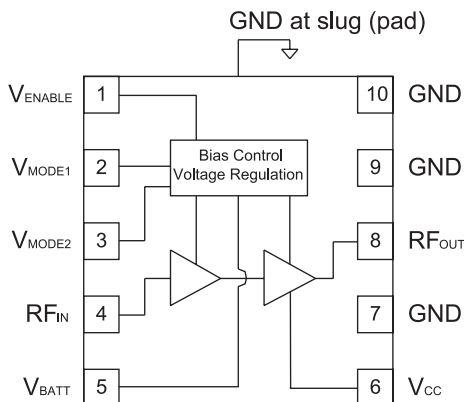

Figure 1: Block Diagram

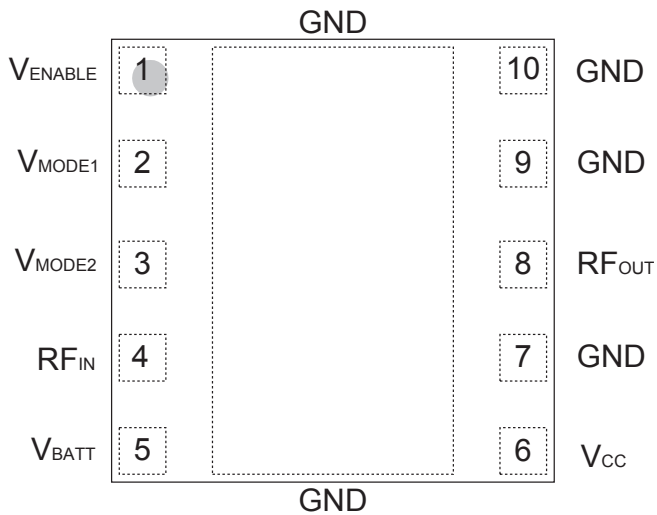

Figure 2: Pinout (X-ray Top View)

Table 1: Pin Description

PIN	NAME	DESCRIPTION
1	V_{ENABLE}	PA Enable Voltage
2	V_{MODE1}	Mode Control Voltage 1
3	V_{MODE2}	Mode Control Voltage 2
4	RF_{IN}	RF Input
5	V_{BATT}	Battery Voltage
6	V_{CC}	Supply Voltage
7	GND	Ground
8	RF_{OUT}	RF Output
9	GND	Ground
10	GND	Ground

ELECTRICAL CHARACTERISTICS

Table 2: Absolute Minimum and Maximum Ratings

PARAMETER	MIN	MAX	UNIT
Supply Voltage (V_{CC})	0	+5	V
Battery Voltage (V_{BATT})	0	+6	V
Control Voltages (V_{MODE1} , V_{MODE2} , V_{ENABLE})	0	+3.5	V
RF Input Power (P_{IN})	-	+10	dBm
Storage Temperature (T_{STG})	-40	+150	°C

Stresses in excess of the absolute ratings may cause permanent damage. Functional operation is not implied under these conditions. Exposure to absolute ratings for extended periods of time may adversely affect reliability.

Table 3: Operating Ranges

PARAMETER	MIN	TYP	MAX	UNIT	COMMENTS
Operating Frequency (f)	880	-	915	MHz	
Supply Voltage (V_{CC})	+3.2	+3.4	+4.2	V	$P_{OUT} \leq +29$ dBm
Enable Voltage (V_{ENABLE})	+2.15 0	+2.4 -	+3.1 +0.5	V	PA "on" PA "shut down"
Mode Control Voltage (V_{MODE1} , V_{MODE2})	+2.15 0	+2.4 -	+3.1 +0.5	V	Low Bias Mode High Bias Mode
RF Output Power (P_{OUT}) R99 WCDMA, HPM HSPA (MPR=0), HPM R99 WCDMA, LPM HSPA (MPR=0), LPM	28.5 ⁽¹⁾ 27.5 ⁽¹⁾ 15.5 ⁽¹⁾ 14.5 ⁽¹⁾	29 28 16 15	29 28 16 15	dBm	3GPP TS 34.121-1, Rel 7 Table C.11.1.3
Case Temperature (T_C)	-30	-	+90	°C	

The device may be operated safely over these conditions; however, parametric performance is guaranteed only over the conditions defined in the electrical specifications.

Notes:

(1) For operation at $V_{CC} = +3.2$ V, P_{OUT} is derated by 0.5 dB.

Table 4: Electrical Specifications
 (T_C = +25 °C, V_{CC} = +3.4 V, V_{BATT} = +3.4 V, V_{ENABLE} = +2.4 V, 50 Ω system)

PARAMETER	MIN	TYP	MAX	UNIT	COMMENTS		
					P _{OUT}	V _{MODE1}	V _{MODE2}
Gain	24.5 13 10.5	26.5 15 12.5	29 17.5 15	dB	+29 dBm +16 dBm +8 dBm	0 V 2.4 V 2.4 V	0 V 0 V 2.4 V
ACLR1 at 5 MHz offset ⁽¹⁾	- - -	-41 -47 -42	-38 -38 -38	dBc	+29 dBm +16 dBm +8 dBm	0 V 2.4 V 2.4 V	0 V 0 V 2.4 V
ACLR2 at 10 MHz offset	- - -	-53 -56 -61	-48 -48 -48	dBc	+29 dBm +16 dBm +8 dBm	0 V 2.4 V 2.4 V	0 V 0 V 2.4 V
Power-Added Efficiency ⁽¹⁾ (without DC/DC Converter)	38 18 7	42 21 8.5	- - -	%	+29 dBm +16 dBm +8 dBm	0 V 2.4 V 2.4 V	0 V 0 V 2.4 V
Quiescent Current (I _q)	- -	7 15	11 21	mA	V _{MODE1} = +2.4 V, V _{MODE2} = +2.4 V V _{MODE1} = +2.4 V, V _{MODE2} = 0 V		
Mode Control Current	-	0.35	0.8	mA	through V _{MODE} pins, V _{MODE} = +2.4 V		
Enable Current	-	0.45	0.8	mA	through V _{ENABLE} pin		
BATT Current	-	2.5	5	mA	through V _{BATT} pin, V _{MODE1} = +2.4 V, V _{MODE2} = +2.4 V or 0 V		
Leakage Current	-	<1	5	μA	V _{BATT} = +4.2 V, V _{CC} = +4.2 V, V _{ENABLE} = 0 V, V _{MODE1} = 0 V, V _{MODE2} = 0 V		
Noise in Receive Band ⁽²⁾	-	-138	-136	dBm/Hz	P _{OUT} ≤ +29 dBm, V _{MODE1} = 0 V, V _{MODE2} = 0 V		
Harmonics 2fo 3fo, 4fo	- - -	-40 -47	-35 -35	dBc	P _{OUT} ≤ +29 dBm		
Input Impedance	-	-	2:1	VSWR			
Spurious Output Level (all spurious outputs)	-	-	-70	dBc	See Note 3		
Load mismatch stress with no permanent degradation or failure	8:1	-	-	VSWR	Applies over full operating range		

Notes:

(1) ACLR and Efficiency measured at 897.5 MHz.

(2) 925 MHz to 960 MHz.

(3) P_{OUT} ≤ +29 dBm, In-band load VSWR < 5:1, Out-of-band load VSWR < 10:1. Applies over all operating conditions.

APPLICATION INFORMATION

To ensure proper performance, refer to all related Application Notes on the ANADIGICS web site: <http://www.anadigics.com>

Shutdown Mode

The power amplifier may be placed in a shutdown mode by applying logic low levels (see Operating Ranges table) to the V_{ENABLE} , V_{MODE1} and V_{MODE2} voltages.

Bias Modes

The power amplifier may be placed in either a Low Bias mode or a High Bias mode by applying the appropriate logic level (see Operating Ranges table) to the V_{MODE}

voltages. The Bias Control table lists the recommended modes of operation for various applications.

Three operating modes are recommended to optimize current consumption. High Bias/High Power operating mode is for P_{OUT} levels ≥ 16 dBm. At ~ 16 dBm - 7 dBm, the PA should be "Mode Switched" to Medium Bias Mode. For P_{OUT} levels $\leq \sim 8$ dBm, the PA can be switched to Low Bias/Low Power Mode used for this P_{OUT} range for even lower quiescent current consumption.

Table 5: Bias Control

APPLICATION	P_{OUT} LEVELS	BIAS MODE	V_{ENABLE}	V_{MODE1}	V_{MODE2}	V_{CC}	V_{BATT}
WCDMA - low power (Low Bias Mode)	$\leq +8$ dBm	Low	+2.4 V	+2.4 V	+2.4 V	3.2 - 4.2 V	≥ 3.2 V
WCDMA - med power (Medium Bias Mode)	$\leq +16$ dBm	Low	+2.4 V	+2.4 V	0 V	3.2 - 4.2 V	≥ 3.2 V
WCDMA - high power (High Bias Mode)	$> +16$ dBm	High	+2.4 V	0 V	0 V	3.2 - 4.2 V	≥ 3.2 V
Optional lower V_{CC} in low power mode	$\leq +7$ dBm	Low	+2.4 V	+2.4 V	2.4 V	1.5 V	≥ 3.2 V
Shutdown	-	Shutdown	0 V	0 V	0 V	3.2 - 4.2 V	≥ 3.2 V

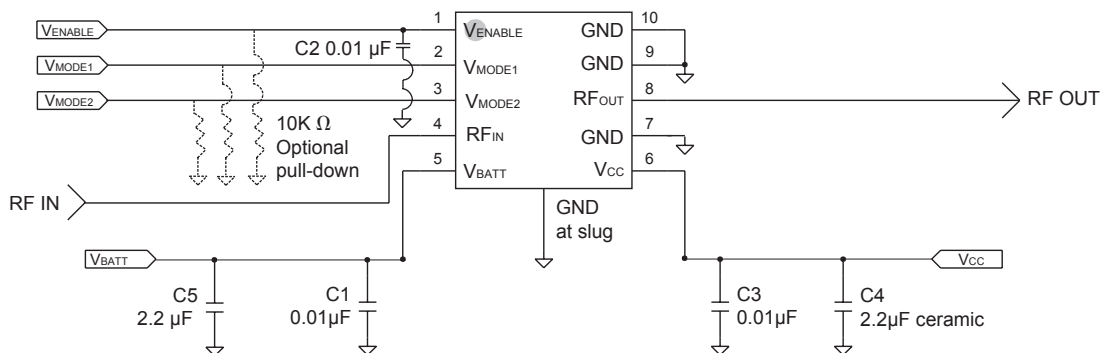
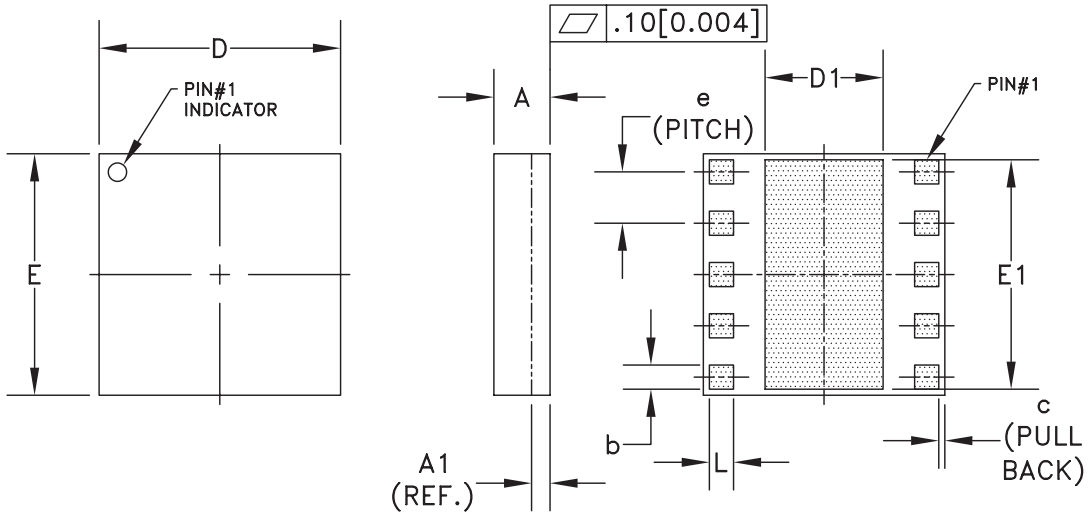

Figure 3: Application Circuit Schematic

PACKAGE OUTLINE



SW_BOL	MILLIMETERS			INCHES			NOTE
	MIN.	NOM.	MAX.	MIN.	NOM.	MAX.	
A	0.88	0.98	1.08	0.034	0.038	0.042	-
A1	0.32 (REF.)			0.0125 (REF.)			-
b	0.35	-	0.60	0.013	-	0.024	3
c	-	0.10	-	-	0.004	-	-
D	3.88	4.00	4.12	0.152	0.157	0.162	-
D1	1.90	-	2.25	0.075	-	0.088	-
E	3.88	4.00	4.12	0.152	0.157	0.162	-
E1	3.75	-	3.85	0.148	-	0.152	-
e	0.85			0.033			3
L	0.35	-	0.60	0.013	-	0.024	3

NOTES:

1. CONTROLLING DIMENSIONS: MILLIMETERS
2. UNLESS SPECIFIED TOLERANCE=±0.076[0.003].
3. PADS (INCLUDING CENTER) SHOWN UNIFORM SIZE FOR REFERENCE ONLY. ACTUAL PAD SIZE AND LOCATION WILL VARY WITHIN MIN. AND MAX. DIMENSIONS ACCORDING TO SPECIFIC LAMINATE DESIGN.

Figure 4: M20 Package Outline - 10 Pin 4 mm x 4 mm x 1 mm Surface Mount Module

TOP BRAND

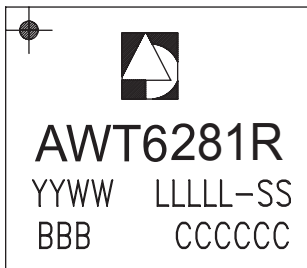

NOTES:

1. ANADIGICS LOGO SIZE: X=0.040±0.010 Y=0.048±0.010
2. PART #
3. YEAR AND WORK WEEK: YYWW: YY = YEAR, WW = WORK WEEK
4. LOT - WAFER I.D.: LLLLL - SS = WAFER/LOT I.D.
5. PIN 1 INDICATOR: MOLD NOTCH -or- INK DOT
6. BOM # BBB
7. COUNTRY CODE: CCCCC
8. TYPE : ELITE
SIZE : AS LARGE AS POSSIBLE
LASER MARKED

Figure 5: Branding Specification - M20 Package

COMPONENT PACKAGING

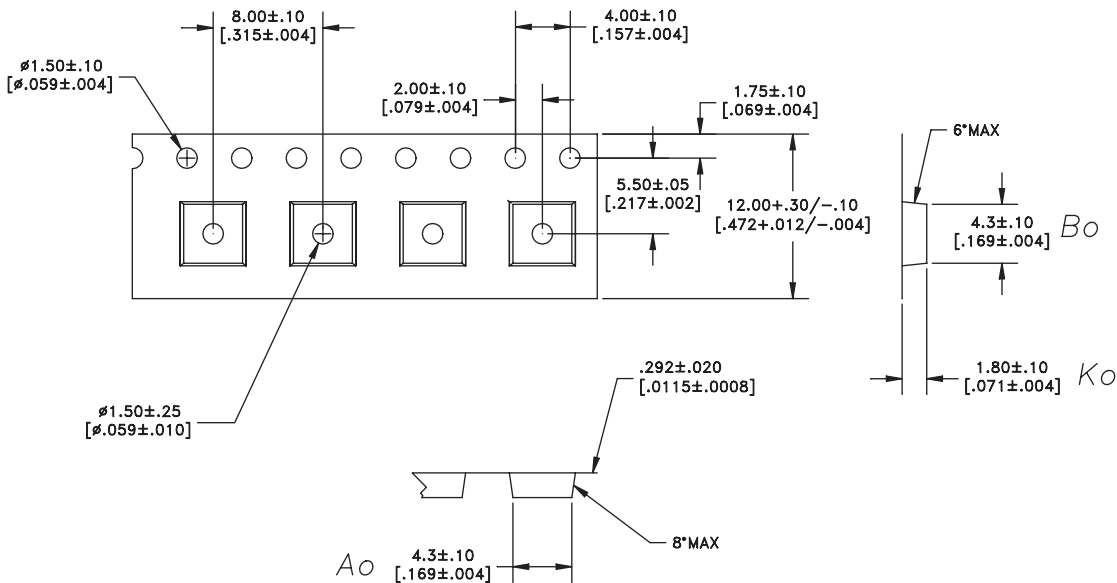

DIMENSIONS ARE IN MILLIMETERS [INCHES]
STANDARD TOLERANCES

Figure 6: Tape & Reel Packaging

Table 6: Tape & Reel Dimensions

PACKAGE TYPE	TAPE WIDTH	POCKET PITCH	REEL CAPACITY	MAX REEL DIA
4 mm x 4 mm x 1 mm	12 mm	8 mm	2500	13"

ORDERING INFORMATION

ORDER NUMBER	TEMPERATURE RANGE	PACKAGE DESCRIPTION	COMPONENT PACKAGING
AWT6281RM20P8	-30 °C to +90 °C	RoHS Compliant 10 Pin 4 mm x 4 mm x 1 mm Surface Mount Module	Tape and Reel, 2500 pieces per Reel
AWT6281RM20P9	-30 °C to +90 °C	RoHS Compliant 10 Pin 4 mm x 4 mm x 1 mm Surface Mount Module	Partial Tape and Reel



ANADIGICS, Inc.
 141 Mount Bethel Road
 Warren, New Jersey 07059, U.S.A.
 Tel: +1 (908) 668-5000
 Fax: +1 (908) 668-5132

URL: <http://www.anadigics.com>
 E-mail: Mktg@anadigics.com

IMPORTANT NOTICE

ANADIGICS, Inc. reserves the right to make changes to its products or to discontinue any product at any time without notice. The product specifications contained in Advanced Product Information sheets and Preliminary Data Sheets are subject to change prior to a product's formal introduction. Information in Data Sheets have been carefully checked and are assumed to be reliable; however, ANADIGICS assumes no responsibilities for inaccuracies. ANADIGICS strongly urges customers to verify that the information they are using is current before placing orders.

WARNING

ANADIGICS products are not intended for use in life support appliances, devices or systems. Use of an ANADIGICS product in any such application without written consent is prohibited.