

Resistance Temperature Detectors (RTDs)

Introduction:

Because of their linearity, stability and accuracy over a wide temperature range, RTDs (resistance temperature detectors) have been the gold standard of temperature measurement devices for many years. Compared to thermocouples and thermistors, RTDs have also been known as the most expensive sensing elements. But recent advances in thin-film technology have produced RTD elements that now offer the design engineer a product that can be competitively priced in OEM quantities.

Resistance Temperature Detectors operate through the principle of electrical resistance changes in pure metal elements. Platinum is the most widely specified RTD element type although nickel, copper, and Balco (nickel-iron) alloys are also used. Platinum is popular due to its wide temperature range, accuracy, stability, as well as the degree of standardization among manufacturers. RTDs are characterized by a linear positive change in resistance with respect to temperature. They exhibit the most linear signal with respect to temperature of any electronic sensing device.

There are two common constructions for RTD elements. **Wire-wound** devices are manufactured by winding a small diameter of wire into a coil on a suitable winding bobbin. A number of methods have been used to protect the wire element from shock and vibration. One common technique is to use a ceramic bobbin with a glass or epoxy seal over the coil and welded connections. An alternative to the wire-wound RTD is the **thin-film** element. It consists of a very thin layer of the base metal, which is deposited onto a ceramic substrate and then laser trimmed to the desired resistance value. Thin-film elements can attain higher resistances with less metal and, thus tend to be less costly than the equivalent wire-wound element.

Most RTD elements are too fragile to be used in their raw form. They're typically connected to extension lead wires and housed in a protective sheath. The housing immobilizes the element while protecting it from mechanical strain and environmental conditions. SS&C specializes in packaging thin-film RTD sensors

in a wide variety of surface, air, and immersion housings that can operate from -100°C to +600°C.

The table below compares some of the different types of base metals that are used in the construction of RTD elements.

Element Material	Temperature Range	Benefits	α (%/°C)
Platinum Thin-film	-200°C to 800°C	Best range Best stability Good linearity	0.375 to 0.385
Nickel Thin-film	-100°C to 260°C	Low cost Best sensitivity	0.618
Balco	-100°C to 204°C	Low cost High sensitivity	0.518 to 0.527

Note: α is normally used to distinguish between RvT curves of the same element or those of different material.

RTD Terminology

RTDs are generally characterized by their base resistance at 0°C. Typical base resistance values available for platinum thin-film RTDs include 100Ω, 500Ω and 1000Ω. For other element types, typical base values include 120Ω for nickel, and 1000Ω and 2000Ω for Balco.

The resistance versus temperature relationship for a platinum thin-film RTD follows the following equation over its operating temperature range:

t(ITS-90)

(°C) Equation

$$\begin{aligned} <0^\circ\text{C} & R_t = R_0 [1 + At + Bt^2 + Ct^3 (t - 100)] \\ >0^\circ\text{C} & R_t = R_0 [1 + At + Bt^2] \end{aligned}$$

Where:

R_t = resistance at temperature t

R_0 = base resistance at 0°C

A, B and C are constants of the equation

t = temperature in accordance with ITS90

The most popular thin-film RTD is manufactured using platinum and has an α of 0.385%/°C and is specified per DIN EN 60751. The A, B and C constants for this material are as follows:

$$A = 3.9083 \times 10^{-3}$$

$$B = -5.775 \times 10^{-7}$$

$$C = -4.183 \times 10^{-12}$$

Resistance Temperature Detectors (RTDs)



Different constants are available for other grades of platinum. Please contact the factory for information on these other platinum grades.

The corresponding equation for one style of a thin-film nickel elements with an α of 0.618%/°C is

$$R_t = R_0 [1 + At + Bt^2 + Ct^3 + Dt^4 + Et^5 + Ft^6]$$

Where:

$$\begin{array}{ll} A = 5.485 \times 10^{-3} & B = 6.65 \times 10^{-6} \\ C = 0 & D = 2.805 \times 10^{-11} \\ E = 0 & F = -2 \times 10^{-17} \end{array}$$

For Balco, individual manufacturers have developed proprietary curves for their elements based on actual measurements at defined points along the resistance versus temperature curve. A number of methods are used to define the curve outside those points. Please contact the factory to obtain information on the types of curves available as well as resistance versus temperature information.

Temperature Coefficient of Resistance (α)

The temperature coefficient of resistance, α , for RTDs is normally defined as the average resistance change per °C over the range 0°C to 100°C divided by R at 0°C. The temperature coefficient is expressed in ohms/ohms/°C or more typically %/°C. Note that this definition differs from the definition of α for an NTC thermistor. The α for an NTC thermistor will vary widely over its temperature range, from as high as 8%/°C to less than 2%/°C. The α for an RTD does not have nearly as large a change over its temperature range. For a standard platinum thin-film RTD, the α is 0.385%/°C while other grades of platinum have α values of 0.3911%/°C and 0.3926%/°C. α for other common RTD elements include:

Thin-film Nickel = 0.618%/°C

Balco = 0.518 to 0.527%/°C

In one sense α defines the sensitivity of the RTD element as it defines the average temperature change of a 1 Ω RTD. However, α is normally used to distinguish between resistance/temperature curves of the same element or those of different materials.

RTDs and self-heating

An RTD is a passive device and requires a measuring current to produce a useful signal. Because of I^2R heating, this current can raise the temperature of the RTD sensing element above that of the ambient temperature unless the extra heat can be dissipated. The amount of self-heat that will be generated is dependent upon the measuring current as well as the ability of the sensor assembly to dissipate that heat. The ability of the sensor to dissipate heat is defined by its dissipation factor, δ , which has units of mW/°C. The definition for δ is the amount of power that it takes to raise the body temperature of the sensing element 1°C. The ability of the sensor to dissipate power is a function of the size and construction of the sensing element as well as the materials that surround it in the assembly and the environment that the sensor is used in. The higher the α , the less amount of self-heating that will occur. The amount of self-heating is more for higher resistance elements used in constant current circuits, as well as in constructions where the sensing element cannot shed heat to its outside environment. Also, self-heating is more in air than in a liquid and in still air rather than moving air.

Effects of leadwire resistance

Because the RTD is a resistive device, any resistance elsewhere in the circuit will cause errors in the readings for the sensor. The most common source of additional resistance is in the leadwires attached to the sensor, especially with assemblies that have long extension leads of heavy AWG# wire. The amount of error introduced into the system will depend upon the length and AWG# of the wire as well as the base resistance value of the RTD.

Leadwire error can be significant, especially with long runs of small diameter leads or low resistance elements. Fortunately, the use of a 3-wire or 4-wire system will reduce errors to negligible levels in most applications. The need for a 3-wire or 4-wire system will be dependent upon the resistance value of the sensing element, the length and AWG of the leadwires as well as the amount of accuracy required. Please contact the factory to discuss your specific application.

Resistance Temperature Detectors (RTDs)

Features:

- Excellent long-term stability
- Platinum and nickel elements
- -60°C to 250°C operation for Nickel
- -200°C to 600°C operation for Platinum
- Values from 100Ω to 1,000Ω
- Small size, fast response time
- Resistant to vibration and thermal shock
- Available in standard DIN class accuracies

Description:

Resistance temperature detectors (RTDs) are characterized by a linear change in resistance with respect to temperature. RTDs exhibit the most linear signal with respect to temperature of any sensing device. RTDs are specified primarily where accuracy and stability are critical to the application. RTDs operate through the principal of electrical resistance changes in pure metal elements. SS&C offers elements manufactured with platinum, the most common element, as well as nickel. The RTD element consists of a thin film of platinum or nickel which is deposited onto a ceramic substrate and laser trimmed to the desired resistance. Thin-film elements attain higher resistances with less metal and, thus, tend to be less costly than the equivalent wire-wound element.

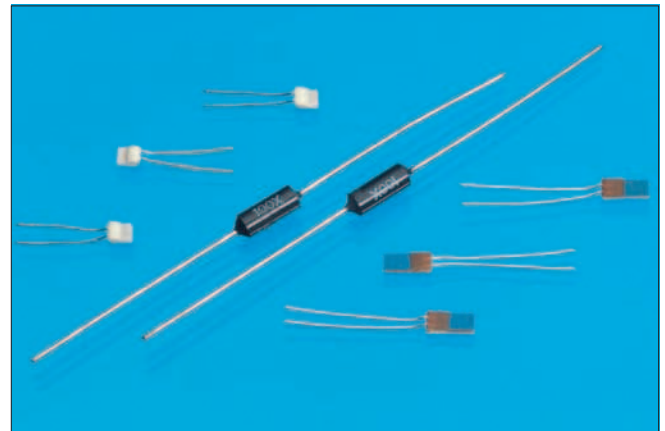

Resistance Temperature Detectors

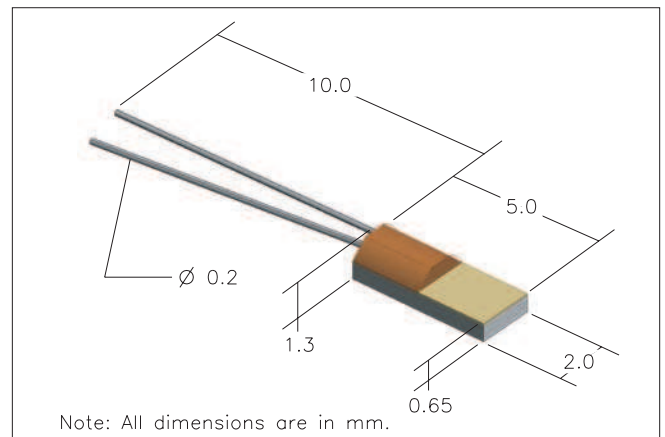

Drawing of a Nickel RTD

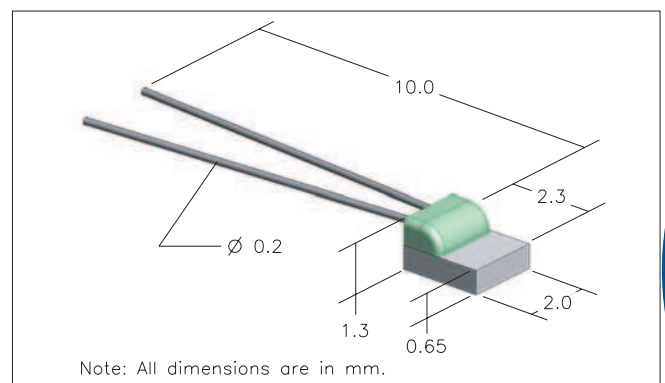

Drawing of a Platinum RTD

Ordering Information			
SS&C Part Number	RTD Type	R@0°C (Ω)	DIN Class
RP102T22	Platinum	100	A, B
RP502T22	Platinum	500	A, B
RP103T22	Platinum	1,000	A, B
RN102T25	Nickel	100	1/2 DIN, DIN 43760
RN502T25	Nickel	500	1/2 DIN, DIN 43760
RN103T25	Nickel	1,000	1/2 DIN, DIN 43760

—
 Basic P/N RTD Type Width in mm Length in mm Tolerance Class

Examples: RP102T22-A..... Platinum RTD, 100Ω@0°C, thin-film element, 2mm x 2mm, DIN Class A
 RN502T25-5D..... Nickel RTD, 500Ω@0°C, thin-film element, 2mm x 5mm, 1/2 DIN

Resistance Temperature Detectors (RTD's)



Resistance tolerance and temperature accuracy

Accuracy classes for platinum RTDs are defined by IEC 751 and are typically listed as either DIN Class A or DIN Class B. The following table shows the accuracies associated with the two class of elements.

Temperature accuracies according to IEC751 and DIN EN 60751

Temperature (°C)	Class A Limit	Class B Limit
-200	±0.55°C	±1.3°C
-100	±0.35°C	±0.8°C
0	±0.15°C	±0.3°C
100	±0.35°C	±0.8°C
200	±0.55°C	±1.3°C
300	±0.75°C	±1.8°C
400	±0.95°C	±2.3°C
500	±1.15°C	±2.8°C
600	±1.35°C	±3.3°C
350	±1.45°C	±3.6°C

These tolerances can be specified in another way in the following formulas:

$$\text{Class A : } \Delta t = \pm(0.15^{\circ}\text{C} + 0.002 |t|)$$

$$\text{Class B : } \Delta t = \pm(0.3^{\circ}\text{C} + 0.005 |t|)$$

Note : |t| is absolute value of temperature in °C

For thin-film nickel RTDs, they are typically broken up into three classes of temperature accuracies as defined by DIN 43760. These classes are as follows:

Class	± Temperature accuracy in °C	
	t < 0°C	t > 0°C
1/2 DIN	0.2 + 0.014 [T]	0.2 + 0.0035 [T]
DIN 43760	0.4 + 0.028 [T]	0.4 + 0.007 [T]
2 x DIN	0.8 + 0.028 [T]	0.8 + 0.007 [T]

No specific standard exists for defining temperature accuracies for Balco RTDs. However a typical interchangeability would be ±1°C at 0°C for Balco.

The following table lists R_t/R_0 for the three most common types of RTDs used by SS&C. To obtain the value at any temperature multiply the R_t/R_0 value at that temperature by the base resistance of the part, R_0 . For example for a platinum RTD with a $R_0 = 1000\Omega$, the nominal resistance value for the part at 230°C would be $1.868 \times 1000 = 1868\Omega$.

Temp (°C)	R_t/R_0			Temp (°C)	R_t/R_0		
	Platinum	Nickel	Balco		Platinum	Nickel	Balco
-50	0.803	0.743	0.810	110	1.423	1.688	1.514
-40	0.843	0.791	0.845	120	1.461	1.760	1.567
-30	0.882	0.841	0.882	130	1.498	1.833	1.622
-20	0.922	0.893	0.920	140	1.536	1.909	1.677
-10	0.961	0.945	0.960	150	1.573	1.986	
0	1.000	1.000	1.000	160	1.611	2.066	
10	1.039	1.055	1.041	170	1.648	2.148	
20	1.078	1.112	1.084	180	1.685	2.231	
30	1.117	1.171	1.127	190	1.722	2.318	
40	1.155	1.230	1.172	200	1.759	2.407	
50	1.194	1.291	1.218	210	1.795	2.498	
60	1.232	1.353	1.264	220	1.832	2.592	
70	1.271	1.417	1.312	230	1.868	2.689	
80	1.309	1.482	1.361	240	1.905	2.789	
90	1.347	1.549	1.411	250	1.941	2.892	
100	1.385	1.618	1.462	260	1.977	2.998	