



Device Overview

The 89HPES32T8G2 is a member of the IDT PRECISE™ family of PCI Express® switching solutions. The PES32T8G2 is a 32-lane, 8-port switch optimized for PCI Express Gen2 packet switching in high-performance applications. Target applications include servers, storage, communications, embedded systems, and multi-host or intelligent I/O based systems with inter-domain communication.

Features

◆ High Performance Non-Blocking Switch Architecture

- 32-lane 8-port PCIe switch
 - *Four x8 switch ports each of which can bifurcate to two x4 ports (total of eight x4 ports)*
- Integrated SerDes supports 5.0 GT/s Gen2 and 2.5 GT/s Gen1 operation
- Delivers up to 32 GBps (256 Gbps) of switching capacity
- Supports 128 Bytes to 2 KB maximum payload size
- Low latency cut-through architecture
- Supports one virtual channel and eight traffic classes

◆ Standards and Compatibility

- PCI Express Base Specification 2.0 compliant
- Implements the following optional PCI Express features
 - *Advanced Error Reporting (AER) on all ports*
 - *End-to-End CRC (ECRC)*
 - *Access Control Services (ACS)*
 - *Power Budgeting Enhanced Capability*
 - *Device Serial Number Enhanced Capability*
 - *Sub-System ID and Sub-System Vendor ID Capability*
 - *Internal Error Reporting ECN*
 - *Multicast ECN*
 - *VGA and ISA enable*
 - *L0s and L1 ASPM*
 - *ARI ECN*

◆ Port Configurability

- x4 and x8 ports
 - *Ability to merge adjacent x4 ports to create a x8 port*
- Automatic per port link width negotiation (x8 → x4 → x2 → x1)
- Crosslink support
- Automatic lane reversal
- Autonomous and software managed link width and speed control
- Per lane SerDes configuration
 - *De-emphasis*
 - *Receive equalization*

- *Drive strength*

◆ Initialization / Configuration

- Supports Root (BIOS, OS, or driver), Serial EEPROM, or SMBus switch initialization
- Common switch configurations are supported with pin strapping (no external components)
- Supports in-system Serial EEPROM initialization/programming

◆ Quality of Service (QoS)

- Port arbitration
 - *Round robin*
- Request metering
 - *IDT proprietary feature that balances bandwidth among switch ports for maximum system throughput*
- High performance switch core architecture
 - *Combined Input Output Queued (CIOQ) switch architecture with large buffers*

◆ Multicast

- Compliant to the PCI-SIG multicast ECN
- Supports arbitrary multicasting of Posted transactions
- Supports 64 multicast groups
- Multicast overlay mechanism support
- ECRC regeneration support

◆ Clocking

- Supports 100 MHz and 125 MHz reference clock frequencies
- Flexible clocking modes
 - *Common clock*
 - *Non-common clock*

◆ Hot-Plug and Hot Swap

- Hot-plug controller on all ports
 - *Hot-plug supported on all downstream switch ports*
- All ports support hot-plug using low-cost external I²C I/O expanders
- Configurable presence detect supports card and cable applications
- GPE output pin for hot-plug event notification
 - *Enables SCI/SMI generation for legacy operating system support*
- Hot-swap capable I/O

◆ Power Management

- Supports D0, D3hot and D3 power management states
- Active State Power Management (ASPM)
 - *Supports L0, L0s, L1, L2/L3 Ready and L3 link states*
 - *Configurable L0s and L1 entry timers allow performance/power-savings tuning*

- Supports PCI Express Power Budgeting Capability
- SerDes power savings
 - *Supports low swing / half-swing SerDes operation*
 - *SerDes optionally turned-off in D3hot*
 - *SerDes associated with unused ports are turned-off*
 - *SerDes associated with unused lanes are placed in a low power state*

◆ 9 General Purpose I/O

◆ Reliability, Availability and Serviceability (RAS)

- ECRC support
- AER on all ports
- SECDED ECC protection on all internal RAMs
- End-to-end data path parity protection
- Checksum Serial EEPROM content protected
- Autonomous link reliability (preserves system operation in the presence of faulty links)
- Ability to generate an interrupt (INTx or MSI) on link up/down transitions

◆ Test and Debug

- On-chip link activity and status outputs available for Port 0 (upstream port)
- Per port link activity and status outputs available using external I²C I/O expander for all other ports
- SerDes test modes
- Supports IEEE 1149.6 AC JTAG and IEEE 1149.1 JTAG

◆ Power Supplies

- Requires only two power supply voltages (1.0 V and 2.5 V)
Note that a 3.3V is preferred for V_{DD}I/O
- No power sequencing requirements

◆ Packaged in a 23mm x 23mm 484-ball Flip Chip BGA with 1mm ball spacing

Product Description

Utilizing standard PCI Express interconnect, the PES32T8G2 provides the most efficient fan-out solution for applications requiring high throughput, low latency, and simple board layout with a minimum number of board layers. It provides 32 GBps (256 Gbps) of aggregated, full-duplex switching capacity through 32 integrated serial lanes, using proven and robust IDT technology. Each lane provides 5 GT/s of bandwidth in both directions and is fully compliant with PCI Express Base Specification, Revision 2.0.

The PES32T8G2 is based on a flexible and efficient layered architecture. The PCI Express layer consists of SerDes, Physical, Data Link and Transaction layers in compliance with PCI Express Base specification Revision 2.0. The PES32T8G2 can operate either as a store and forward or cut-through switch. It supports eight Traffic Classes (TCs) and one Virtual Channel (VC) with sophisticated resource management to enable efficient switching and I/O connectivity for servers, storage, and embedded processors with limited connectivity.

Block Diagram

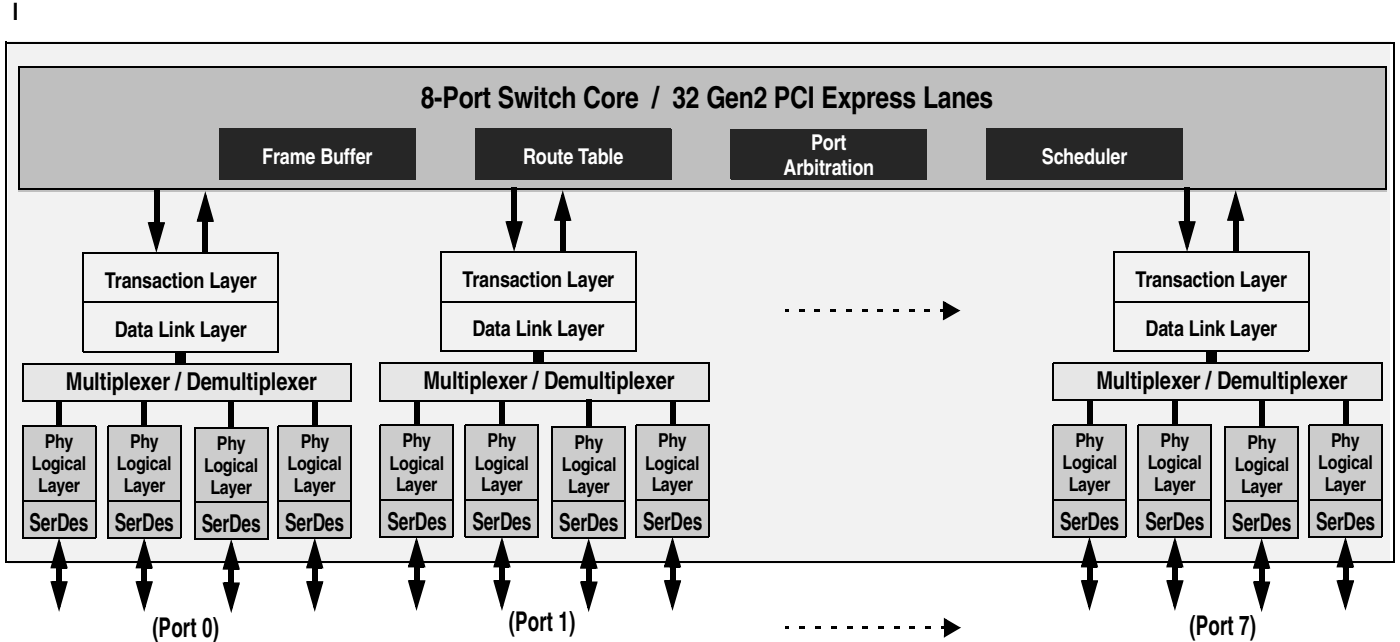

Figure 1 Internal Block Diagram

SMBus Interface

The PES32T8G2 contains two SMBus interfaces. The slave interface provides full access to the configuration registers in the PES32T8G2, allowing every configuration register in the device to be read or written by an external agent. The master interface allows the default configuration register values of the PES32T8G2 to be overridden following a reset with values programmed in an external serial EEPROM. The master interface is also used by an external Hot-Plug I/O expander.

Each of the two SMBus interfaces contain an SMBus clock pin and an SMBus data pin. In addition, the slave SMBus has SSMBADDR1 and SSMBADDR2 pins. As shown in Figure 2, the master and slave SMBuses may only be used in a split configuration.

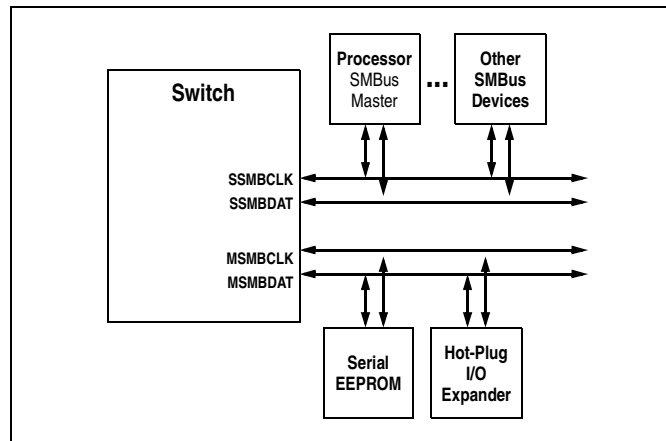

Figure 2 Split SMBus Interface Configuration

The switch's SMBus master interface does not support SMBus arbitration. As a result, the switch's SMBus master must be the only master in the SMBus lines that connect to the serial EEPROM and I/O expander slaves. In the split configuration, the master and slave SMBuses operate as two independent buses; thus, multi-master arbitration is not required.

Hot-Plug Interface

The PES32T8G2 supports PCI Express Hot-Plug on each downstream port. To reduce the number of pins required on the device, the PES32T8G2 utilizes an external I/O expander, such as that used on PC motherboards, connected to the SMBus master interface. Following reset and configuration, whenever the state of a Hot-Plug output needs to be modified, the PES32T8G2 generates an SMBus transaction to the I/O expander with the new value of all of the outputs. Whenever a Hot-Plug input changes, the I/O expander generates an interrupt which is received on the IOEXPINTN input pin (alternate function of GPIO) of the PES32T8G2. In response to an I/O expander interrupt, the PES32T8G2 generates an SMBus transaction to read the state of all of the Hot-Plug inputs from the I/O expander.

General Purpose Input/Output

The PES32T8G2 provides 9 General Purpose Input/Output (GPIO) pins that may be used by the system designer as bit I/O ports. Each GPIO pin may be configured independently as an input or output through software control. Some GPIO pins are shared with other on-chip functions. These alternate functions may be enabled via software, SMBus slave interface, or serial configuration EEPROM.

Pin Description

The following tables list the functions of the pins provided on the PES32T8G2. Some of the functions listed may be multiplexed onto the same pin. The active polarity of a signal is defined using a suffix. Signals ending with an “N” are defined as being active, or asserted, when at a logic zero (low) level. All other signals (including clocks, buses, and select lines) will be interpreted as being active, or asserted, when at a logic one (high) level.

Signal	Type	Name/Description
PE00RP[3:0] PE00RN[3:0]	I	PCI Express Port 0 Serial Data Receive. Differential PCI Express receive pairs for port 0.
PE00TP[3:0] PE00TN[3:0]	O	PCI Express Port 0 Serial Data Transmit. Differential PCI Express transmit pairs for port 0.
PE01RP[3:0] PE01RN[3:0]	I	PCI Express Port 1 Serial Data Receive. Differential PCI Express receive pairs for port 1. When port 0 is merged with port 1, these signals become port 0 receive pairs for lanes 4 through 7.
PE01TP[3:0] PE01TN[3:0]	O	PCI Express Port 1 Serial Data Transmit. Differential PCI Express transmit pairs for port 1. When port 0 is merged with port 1, these signals become port 0 transmit pairs for lanes 4 through 7.
PE02RP[3:0] PE02RN[3:0]	I	PCI Express Port 2 Serial Data Receive. Differential PCI Express receive pairs for port 2.
PE02TP[3:0] PE02TN[3:0]	O	PCI Express Port 2 Serial Data Transmit. Differential PCI Express transmit pairs for port 2.
PE03RP[3:0] PE03RN[3:0]	I	PCI Express Port 3 Serial Data Receive. Differential PCI Express receive pairs for port 3. When port 2 is merged with port 3, these signals become port 2 receive pairs for lanes 4 through 7.
PE03TP[3:0] PE03TN[3:0]	O	PCI Express Port 3 Serial Data Transmit. Differential PCI Express transmit pairs for port 3. When port 2 is merged with port 3, these signals become port 2 transmit pairs for lanes 4 through 7.
PE04RP[3:0] PE04RN[3:0]	I	PCI Express Port 4 Serial Data Receive. Differential PCI Express receive pairs for port 4.
PE04TP[3:0] PE04TN[3:0]	O	PCI Express Port 4 Serial Data Transmit. Differential PCI Express transmit pairs for port 4.
PE05RP[3:0] PE05RN[3:0]	I	PCI Express Port 5 Serial Data Receive. Differential PCI Express receive pairs for port 5. When port 4 is merged with port 5, these signals become port 4 receive pairs for lanes 4 through 7.
PE05TP[3:0] PE05TN[3:0]	O	PCI Express Port 5 Serial Data Transmit. Differential PCI Express transmit pairs for port 5. When port 4 is merged with port 5, these signals become port 4 transmit pairs for lanes 4 through 7.
PE06RP[3:0] PE06RN[3:0]	I	PCI Express Port 6 Serial Data Receive. Differential PCI Express receive pairs for port 6.
PE06TP[3:0] PE06TN[3:0]	O	PCI Express Port 6 Serial Data Transmit. Differential PCI Express transmit pairs for port 6.
PE07RP[3:0] PE07RN[3:0]	I	PCI Express Port 7 Serial Data Receive. Differential PCI Express receive pairs for port 7. When port 6 is merged with port 7, these signals become port 6 receive pairs for lanes 4 through 7.
PE07TP[3:0] PE07TN[3:0]	O	PCI Express Port 7 Serial Data Transmit. Differential PCI Express transmit pairs for port 7. When port 6 is merged with port 7, these signals become port 6 transmit pairs for lanes 4 through 7.

Table 1 PCI Express Interface Pins

Signal	Type	Name/Description
GCLKN[1:0] GCLKP[1:0]	I	Global Reference Clock. Differential reference clock input pair. This clock is used as the reference clock by on-chip PLLs to generate the clocks required for the system logic. The frequency of the differential reference clock is determined by the GCLKFSEL signal.

Table 2 Reference Clock Pins

Signal	Type	Name/Description
MSMBCLK	I/O	Master SMBus Clock. This bidirectional signal is used to synchronize transfers on the master SMBus.
MSMBDAT	I/O	Master SMBus Data. This bidirectional signal is used for data on the master SMBus.
SSMBADDR[2,1]	I	Slave SMBus Address. These pins determine the SMBus address to which the slave SMBus interface responds.
SSMBCLK	I/O	Slave SMBus Clock. This bidirectional signal is used to synchronize transfers on the slave SMBus.
SSMBDAT	I/O	Slave SMBus Data. This bidirectional signal is used for data on the slave SMBus.

Table 3 SMBus Interface Pins

Signal	Type	Name/Description
GPIO[0]	I/O	General Purpose I/O. This pin can be configured as a general purpose I/O pin.
GPIO[1]	I/O	General Purpose I/O. This pin can be configured as a general purpose I/O pin.
GPIO[2]	I/O	General Purpose I/O. This pin can be configured as a general purpose I/O pin.
GPIO[3]	I/O	General Purpose I/O. This pin can be configured as a general purpose I/O pin.
GPIO[4]	I/O	General Purpose I/O. This pin can be configured as a general purpose I/O pin. 1st Alternate function — Reserved 2nd Alternate function pin name: POLINKUPN 2nd Alternate function pin type: Output 2nd Alternate function: Port 0 Link Up Status output.
GPIO[5]	I/O	General Purpose I/O. This pin can be configured as a general purpose I/O pin. 1st Alternate function pin name: GPEN 1st Alternate function pin type: Output 1st Alternate function: Hot-plug general purpose even output. 2nd Alternate function pin name: P0ACTIVEN 2nd Alternate function pin type: Output 2nd Alternate function: Port 0 Link Active Status Output.

Table 4 General Purpose I/O Pins (Part 1 of 2)

Signal	Type	Name/Description
GPIO[6]	I/O	General Purpose I/O. This pin can be configured as a general purpose I/O pin.
GPIO[7]	I/O	General Purpose I/O. This pin can be configured as a general purpose I/O pin.
GPIO[8]	I/O	General Purpose I/O. This pin can be configured as a general purpose I/O pin. Alternate function pin name: IOEXPINTN Alternate function pin type: Input Alternate function: IO expander interrupt.

Table 4 General Purpose I/O Pins (Part 2 of 2)

Signal	Type	Name/Description
CLKMODE[1:0]		Clock Mode. These signals determine the port clocking mode used by ports of the device.
GCLKFSEL	I	Global Clock Frequency Select. These signals select the frequency of the GCLKP and GCLKN signals. 0x0 100 MHz 0x1 125 MHz
P01MERGEN	I	Port 0 and 1 Merge. P01MERGEN is an active low signal. It is pulled low internally. When this pin is low, port 0 is merged with port 1 to form a single x8 port. The Serdes lanes associated with port 1 become lanes 4 through 7 of port 0. When this pin is high, port 0 and port 1 are not merged, and each operates as a single x4 port.
P23MERGEN	I	Port 2 and 3 Merge. P23MERGEN is an active low signal. It is pulled low internally. When this pin is low, port 2 is merged with port 3 to form a single x8 port. The Serdes lanes associated with port 3 become lanes 4 through 7 of port 2. When this pin is high, port 2 and port 3 are not merged, and each operates as a single x4 port.
P45MERGEN	I	Port 4 and 5 Merge. P45MERGEN is an active low signal. It is pulled low internally. When this pin is low, port 4 is merged with port 5 to form a single x8 port. The Serdes lanes associated with port 5 become lanes 4 through 7 of port 4. When this pin is high, port 4 and port 5 are not merged, and each operates as a single x4 port.
P67MERGEN	I	Port 6 and 7 Merge. P67MERGEN is an active low signal. It is pulled low internally. When this pin is low, port 6 is merged with port 7 to form a single x8 port. The Serdes lanes associated with port 7 become lanes 4 through 7 of port 6. When this pin is high, port 6 and port 7 are not merged, and each operates as a single x4 port.

Table 5 System Pins (Part 1 of 2)

Signal	Type	Name/Description
PERSTN	I	Global Reset. Assertion of this signal resets all logic inside PES32T8G2.
RSTHALT	I	Reset Halt. When this signal is asserted during a PCI Express fundamental reset, PES32T8G2 executes the reset procedure and remains in a reset state with the Master and Slave SMBuses active. This allows software to read and write registers internal to the device before normal device operation begins. The device exits the reset state when the RSTHALT bit is cleared in the SWCTL register by an SMBus master.
SWMODE[3:0]	I	Switch Mode. These configuration pins determine the PES32T8G2 switch operating mode. Note: These pins should be static and not change following the negation of PERSTN. 0x0 - Normal switch mode 0x1 - Normal switch mode with Serial EEPROM initialization 0x2 through 0x7 - Reserved 0x8 - Single partition with port 0 selected as the upstream port (port 2 disabled) 0x9 - Single partition with port 2 selected as the upstream port (port 0 disabled) 0xA - Single partition with Serial EEPROM initialization and port 0 selected as the upstream port (port 2 disabled) 0xB - Single partition with Serial EEPROM initialization and port 2 selected as the upstream port (port 0 disabled) 0xE - Reserved 0xF - Reserved

Table 5 System Pins (Part 2 of 2)

Signal	Type	Name/Description
JTAG_TCK	I	JTAG Clock. This is an input test clock used to clock the shifting of data into or out of the boundary scan logic or JTAG Controller. JTAG_TCK is independent of the system clock with a nominal 50% duty cycle.
JTAG_TDI	I	JTAG Data Input. This is the serial data input to the boundary scan logic or JTAG Controller.
JTAG_TDO	O	JTAG Data Output. This is the serial data shifted out from the boundary scan logic or JTAG Controller. When no data is being shifted out, this signal is tri-stated.
JTAG_TMS	I	JTAG Mode. The value on this signal controls the test mode select of the boundary scan logic or JTAG Controller.
JTAG_TRST_N	I	JTAG Reset. This active low signal asynchronously resets the boundary scan logic and JTAG TAP Controller. An external pull-up on the board is recommended to meet the JTAG specification in cases where the tester can access this signal. However, for systems running in functional mode, one of the following should occur: 1) actively drive this signal low with control logic 2) statically drive this signal low with an external pull-down on the board

Table 6 Test Pins

Signal	Type	Name/Description
REFRES00	I/O	Port 0 External Reference Resistor. Provides a reference for the Port 0 SerDes bias currents and PLL calibration circuitry. A 3 kOhm +/- 1% resistor should be connected from this pin to ground.
REFRES01	I/O	Port 1 External Reference Resistor. Provides a reference for the Port 1 SerDes bias currents and PLL calibration circuitry. A 3 kOhm +/- 1% resistor should be connected from this pin to ground.
REFRES02	I/O	Port 2 External Reference Resistor. Provides a reference for the Port 2 SerDes bias currents and PLL calibration circuitry. A 3 kOhm +/- 1% resistor should be connected from this pin to ground.
REFRES03	I/O	Port 3 External Reference Resistor. Provides a reference for the Port 3 SerDes bias currents and PLL calibration circuitry. A 3 kOhm +/- 1% resistor should be connected from this pin to ground.
REFRES04	I/O	Port 4 External Reference Resistor. Provides a reference for the Port 4 SerDes bias currents and PLL calibration circuitry. A 3 kOhm +/- 1% resistor should be connected from this pin to ground.
REFRES05	I/O	Port 5 External Reference Resistor. Provides a reference for the Port 5 SerDes bias currents and PLL calibration circuitry. A 3 kOhm +/- 1% resistor should be connected from this pin to ground.
REFRES06	I/O	Port 6 External Reference Resistor. Provides a reference for the Port 6 SerDes bias currents and PLL calibration circuitry. A 3 kOhm +/- 1% resistor should be connected from this pin to ground.
REFRES07	I/O	Port 7 External Reference Resistor. Provides a reference for the Port 7 SerDes bias currents and PLL calibration circuitry. A 3 kOhm +/- 1% resistor should be connected from this pin to ground.
REFRESPLL	I/O	PLL External Reference Resistor. Provides a reference for the PLL bias currents and PLL calibration circuitry. A 3K Ohm +/- 1% resistor should be connected from this pin to ground.
V _{DD} CORE	I	Core V_{DD}. Power supply for core logic (1.0V).
V _{DD} I/O	I	I/O V_{DD}. LVTTTL I/O buffer power supply (2.5V or preferred 3.3V).
V _{DD} PEA	I	PCI Express Analog Power. Serdes analog power supply (1.0V).
V _{DD} PEHA	I	PCI Express Analog High Power. Serdes analog power supply (2.5V).
V _{DD} PETA	I	PCI Express Transmitter Analog Voltage. Serdes transmitter analog power supply (1.0V).
V _{SS}	I	Ground.

Table 7 Power, Ground, and SerDes Resistor Pins

Pin Characteristics

Note: Some input pads of the switch do not contain internal pull-ups or pull-downs. Unused SMBus and System inputs should be tied off to appropriate levels. This is especially critical for unused control signal inputs which, if left floating, could adversely affect operation. Also, floating pins can cause a slight increase in power consumption. Unused Serdes (Rx and Tx) pins should be left floating. Finally, No Connection pins should not be connected.

Function	Pin Name	Type	Buffer	I/O Type	Internal Resistor ¹	Notes
PCI Express Interface	PE00RN[3:0]	I	PCIe differential ²	Serial Link		
	PE00RP[3:0]	I				
	PE00TN[3:0]	O				
	PE00TP[3:0]	O				
	PE01RN[3:0]	I				
	PE01RP[3:0]	I				
	PE01TN[3:0]	O				
	PE01TP[3:0]	O				
	PE02RN[3:0]	I				
	PE02RP[3:0]	I				
	PE02TN[3:0]	O				
	PE02TP[3:0]	O				
	PE03RN[3:0]	I				
	PE03RP[3:0]	I				
	PE03TN[3:0]	O				
	PE03TP[3:0]	O				
	PE04RN[3:0]	I				
	PE04RP[3:0]	I				
	PE04TN[3:0]	O				
	PE04TP[3:0]	O				
	PE05RN[3:0]	I				
	PE05RP[3:0]	I				
	PE05TN[3:0]	O				
	PE05TP[3:0]	O				
	PE06RN[3:0]	I				
	PE06RP[3:0]	I				
	PE06TN[3:0]	O				
	PE06TP[3:0]	O				
	PE07RN[3:0]	I				
	PE07RP[3:0]	I				
PE07TN[3:0]	O					
PE07TP[3:0]	O					
	GCLKN[1:0]	I	HCSL	Diff. Clock Input		Refer to Table 9
	GCLKP[1:0]	I				

Table 8 Pin Characteristics (Part 1 of 2)

Function	Pin Name	Type	Buffer	I/O Type	Internal Resistor ¹	Notes
SMBus	MSMBCLK	I/O	LVTTTL	STI ³		pull-up on board
	MSMBDAT	I/O		STI		pull-up on board
	SSMBADDR[2,1]	I		Input	pull-up	
	SSMBCLK	I/O		STI		pull-up on board
	SSMBDAT	I/O		STI		pull-up on board
General Purpose I/O	GPIO[8:0]	I/O	LVTTTL	STI, High Drive	pull-up	
System Pins	CLKMODE[1:0]	I	LVTTTL	Input	pull-up	
	GCLKFSEL	I			pull-down	
	P01MERGEN	I			pull-down	
	P23MERGEN	I			pull-down	
	P45MERGEN	I			pull-down	
	P67MERGEN	I			pull-down	
	PERSTN	I		STI		
	RSTHALT	I		Input	pull-down	
	SWMODE[3:0]	I			pull-down	
EJTAG / JTAG	JTAG_TCK	I	LVTTTL	STI	pull-up	
	JTAG_TDI	I		STI	pull-up	
	JTAG_TDO	O				
	JTAG_TMS	I		STI	pull-up	
	JTAG_TRST_N	I		STI	pull-up	
SerDes Reference Resistors	REFRES00	I/O	Analog			
	REFRES01	I/O				
	REFRES02	I/O				
	REFRES03	I/O				
	REFRES04	I/O				
	REFRES05	I/O				
	REFRES06	I/O				
	REFRES07	I/O				
	REFRESPLL	I/O				

Table 8 Pin Characteristics (Part 2 of 2)

¹. Internal resistor values under typical operating conditions are 92K Ω for pull-up and 91K Ω for pull-down.

². All receiver pins set the DC common mode voltage to ground. All transmitters must be AC coupled to the media.

³. Schmitt Trigger Input (STI).

Logic Diagram — PES32T8G2

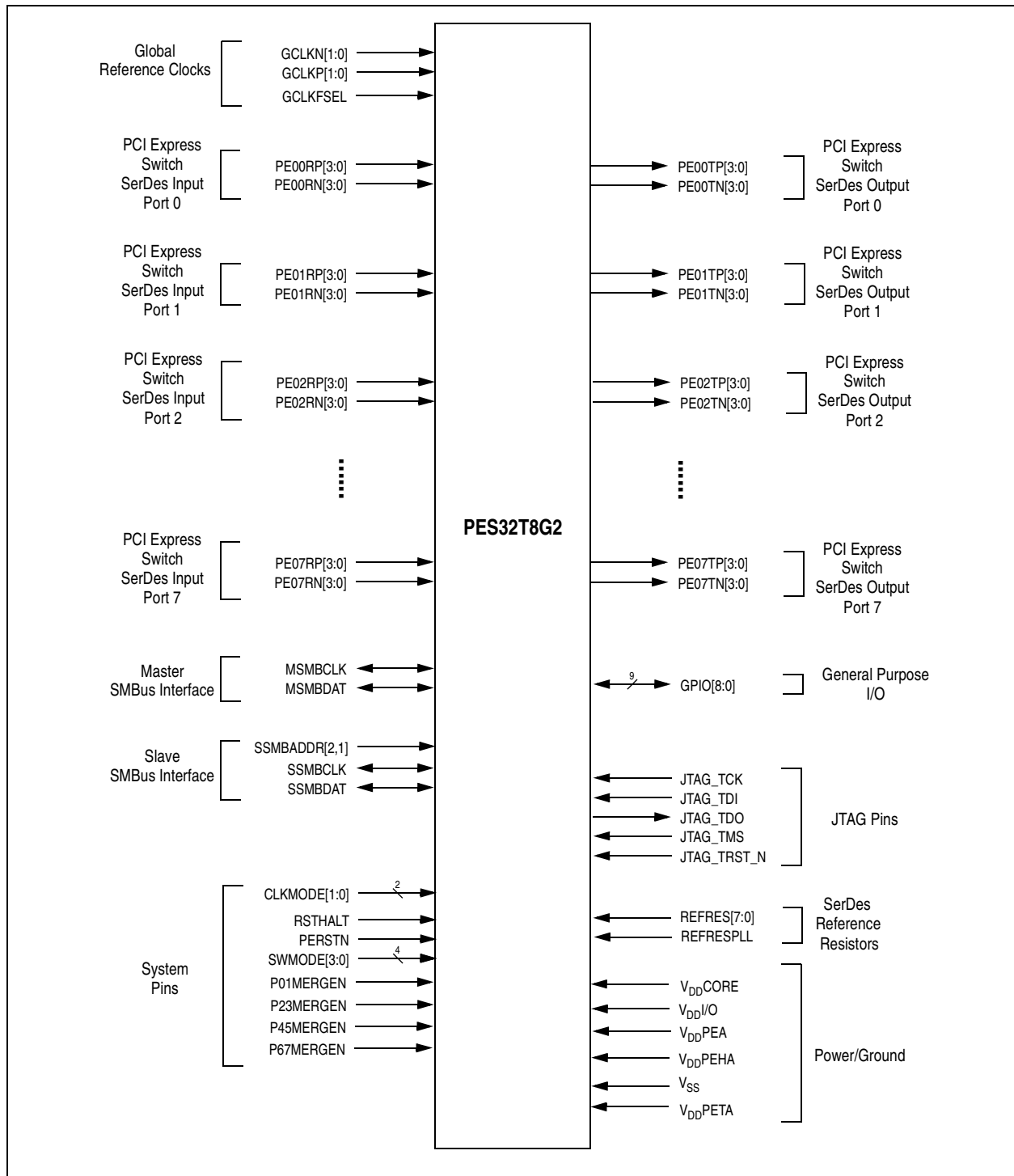

Figure 3 PES32T8G2 Logic Diagram

System Clock Parameters

Values based on systems running at recommended supply voltages and operating temperatures, as shown in Tables 13 and 14.

Parameter	Description	Condition	Min	Typical	Max	Unit
Refclk _{FREQ}	Input reference clock frequency range		100		125 ¹	MHz
T _{C-RISE}	Rising edge rate	Differential	0.6		4	V/ns
T _{C-FALL}	Falling edge rate	Differential	0.6		4	V/ns
V _{IH}	Differential input high voltage	Differential	+150			mV
V _{IL}	Differential input low voltage	Differential			-150	mV
V _{CROSS}	Absolute single-ended crossing point voltage	Single-ended	+250		+550	mV
V _{CROSS-DELTA}	Variation of V _{CROSS} over all rising clock edges	Single-ended			+140	mV
V _{RB}	Ring back voltage margin	Differential	-100		+100	mV
T _{STABLE}	Time before V _{RB} is allowed	Differential	500			ps
T _{PERIOD-AVG}	Average clock period accuracy		-300		2800	ppm
T _{PERIOD-ABS}	Absolute period, including spread-spectrum and jitter		9.847		10.203	ns
T _{CC-JITTER}	Cycle to cycle jitter				150	ps
V _{MAX}	Absolute maximum input voltage				+1.15	V
V _{MIN}	Absolute minimum input voltage		-0.3			V
Duty Cycle	Duty cycle		40		60	%
Rise/Fall Matching	Single ended rising Refclk edge rate versus falling Refclk edge rate			20		%
Z _{C-DC}	Clock source output DC impedance		40		60	Ω

Table 9 Input Clock Requirements

¹ The input clock frequency will be either 100 or 125 MHz depending on signal GCLKFSEL.

AC Timing Characteristics

Parameter	Description	Gen 1			Gen 2			Units
		Min ¹	Typ ¹	Max ¹	Min ¹	Typ ¹	Max ¹	
PCIe Transmit								
UI	Unit Interval	399.88	400	400.12	199.94	200	200.06	ps
T _{TX-EYE}	Minimum Tx Eye Width	0.75			0.75			UI
T _{TX-EYE-MEDIAN-to-MAX-JITTER}	Maximum time between the jitter median and maximum deviation from the median			0.125				UI
T _{TX-RISE} , T _{TX-FALL}	TX Rise/Fall Time: 20% - 80%	0.125			0.15			UI
T _{TX-IDLE-MIN}	Minimum time in idle	20			20			UI

Table 10 PCIe AC Timing Characteristics (Part 1 of 2)

Parameter	Description	Gen 1			Gen 2			Units
		Min ¹	Typ ¹	Max ¹	Min ¹	Typ ¹	Max ¹	
T _{TX-IDLE-SET-TO-IDLE}	Maximum time to transition to a valid Idle after sending an Idle ordered set			8			8	ns
T _{TX-IDLE-TO-DIFF-DATA}	Maximum time to transition from valid idle to diff data			8			8	ns
T _{TX-SKEW}	Transmitter data skew between any 2 lanes			1.3			1.3	ns
T _{MIN-PULSED}	Minimum Instantaneous Lone Pulse Width	NA			0.9			UI
T _{TX-HF-DJ-DD}	Transmitter Deterministic Jitter > 1.5MHz Bandwidth	NA					0.15	UI
T _{RF-MISMATCH}	Rise/Fall Time Differential Mismatch	NA					0.1	UI
PCIe Receive								
UI	Unit Interval	399.88	400	400.12	199.94		200.06	ps
T _{RX-EYE (with jitter)}	Minimum Receiver Eye Width (jitter tolerance)	0.4			0.4			UI
T _{RX-EYE-MEDIUM TO MAX JITTER}	Max time between jitter median & max deviation			0.3				UI
T _{RX-SKEW}	Lane to lane input skew			20			8	ns
T _{RX-HF-RMS}	1.5 — 100 MHz RMS jitter (common clock)	NA					3.4	ps
T _{RX-HF-DJ-DD}	Maximum tolerable DJ by the receiver (common clock)	NA					88	ps
T _{RX-LF-RMS}	10 KHz to 1.5 MHz RMS jitter (common clock)	NA					4.2	ps
T _{RX-MIN-PULSE}	Minimum receiver instantaneous eye width	NA			0.6			UI

Table 10 PCIe AC Timing Characteristics (Part 2 of 2)

¹ Minimum, Typical, and Maximum values meet the requirements under PCI Specification 2.0

Signal	Symbol	Reference Edge	Min	Max	Unit	Timing Diagram Reference
GPIO						
GPIO[8:0] ¹	T _{pw} ²	None	50	—	ns	

Table 11 GPIO AC Timing Characteristics

¹ GPIO signals must meet the setup and hold times if they are synchronous or the minimum pulse width if they are asynchronous.

² The values for this symbol were determined by calculation, not by testing.

Signal	Symbol	Reference Edge	Min	Max	Unit	Timing Diagram Reference
JTAG						
JTAG_TCK	Tper_16a	none	50.0	—	ns	See Figure 4.
	Thigh_16a, Tlow_16a		10.0	25.0	ns	
JTAG_TMS ¹ , JTAG_TDI	Tsu_16b	JTAG_TCK rising	2.4	—	ns	
	Thld_16b		1.0	—	ns	
JTAG_TDO	Tdo_16c	JTAG_TCK falling	—	20	ns	
	Tdz_16c ²		—	20	ns	
JTAG_TRST_N	Tpw_16d ²	none	25.0	—	ns	

Table 12 JTAG AC Timing Characteristics

¹ The JTAG specification, IEEE 1149.1, recommends that JTAG_TMS should be held at 1 while the signal applied at JTAG_TRST_N changes from 0 to 1. Otherwise, a race may occur if JTAG_TRST_N is deasserted (going from low to high) on a rising edge of JTAG_TCK when JTAG_TMS is low, because the TAP controller might go to either the Run-Test/Idle state or stay in the Test-Logic-Reset state.

² The values for this symbol were determined by calculation, not by testing.

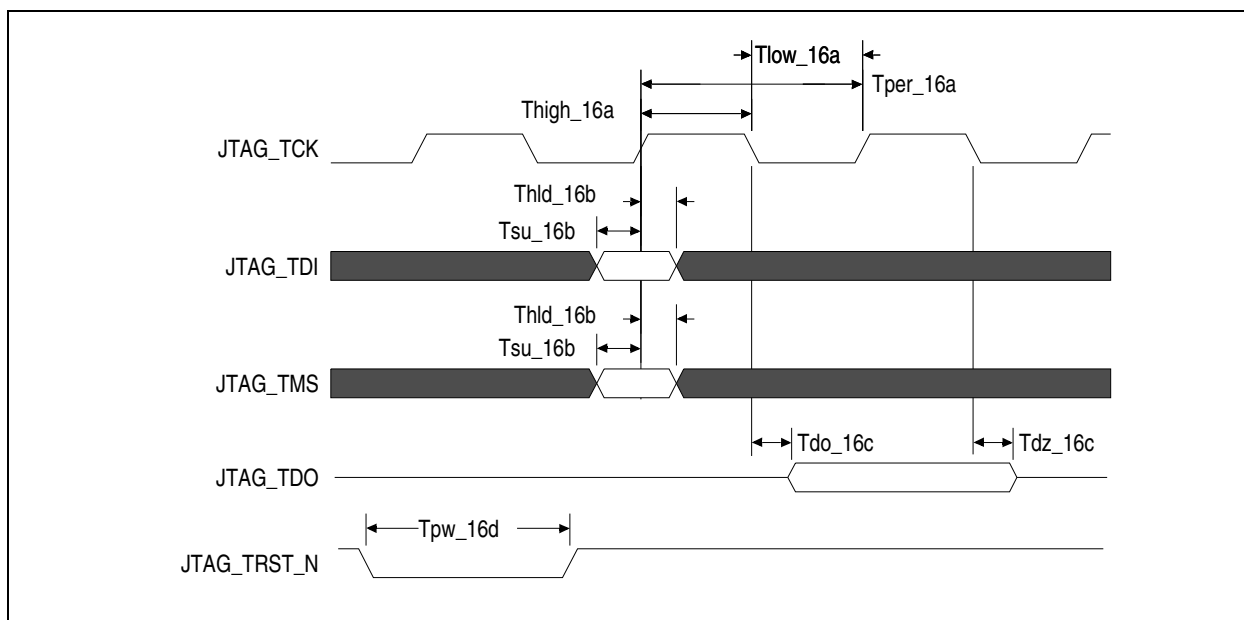

Figure 4 JTAG AC Timing Waveform

Recommended Operating Supply Voltages

Symbol	Parameter	Minimum	Typical	Maximum	Unit
V _{DD} CORE	Internal logic supply	0.9	1.0	1.1	V
V _{DD} I/O	I/O supply except for SerDes	2.25	2.5	2.75	V
		3.125	3.3	3.465	V
V _{DD} PEA ¹	PCI Express Analog Power	0.95	1.0	1.1	V
V _{DD} PEHA ²	PCI Express Analog High Power	2.25	2.5	2.75	V
V _{DD} PETA ¹	PCI Express Transmitter Analog Voltage	0.95	1.0	1.1	V
V _{SS}	Common ground	0	0	0	V

Table 13 PES32T8G2 Operating Voltages

¹ V_{DD}PEA and V_{DD}PETA should have no more than 25mV_{peak-peak} AC power supply noise superimposed on the 1.0V nominal DC value.

² V_{DD}PEHA should have no more than 50mV_{peak-peak} AC power supply noise superimposed on the 2.5V nominal DC value.

Power-Up/Power-Down Sequence

During power supply ramp-up, V_{DD}CORE must remain at least 1.0V below V_{DD}I/O at all times. There are no other power-up sequence requirements for the various operating supply voltages.

The power-down sequence can occur in any order.

Recommended Operating Temperature

Grade	Temperature
Commercial	0°C to +70°C Ambient
Industrial	-40°C to +85°C Ambient

Table 14 PES32T8G2 Operating Temperatures

Power Consumption

Typical power is measured under the following conditions: 25°C Ambient, 35% total link usage on all ports, typical voltages defined in Table 13 (and also listed below).

Maximum power is measured under the following conditions: 70°C Ambient, 85% total link usage on all ports, maximum voltages defined in Table 13 (and also listed below).

Number of Active Lanes per Port		Core Supply		PCIe Analog Supply		PCIe Analog High Supply		PCIe Transmitter Supply		I/O Supply		Total	
		Typ 1.0V	Max 1.1V	Typ 1.0V	Max 1.1V	Typ 2.5V	Max 2.75V	Typ 1.0V	Max 1.1V	Typ 2.5V	Max 2.75V	Typ Power	Max Power
8/8/8/8 (Full Swing)	mA	2850	5000	1514	1826	507	514	561	603	24	29		
	Watts	2.85	5.50	1.51	2.01	1.27	1.41	0.56	0.66	0.06	0.08	6.25	9.67
8/8/8/8 (Half Swing)	mA	2850	5000	1302	1571	507	514	292	313	24	29		
	Watts	2.85	5.50	1.30	1.73	1.27	1.41	0.29	0.34	0.06	0.08	5.77	9.07

Table 15 PES32T8G2 Power Consumption — 2.5V I/O

Number of Active Lanes per Port		Core Supply		PCIe Analog Supply		PCIe Analog High Supply		PCIe Transmitter Supply		I/O Supply		Total	
		Typ 1.0V	Max 1.1V	Typ 1.0V	Max 1.1V	Typ 2.5V	Max 2.75V	Typ 1.0V	Max 1.1V	Typ 3.3V	Max 3.465V	Typ Power	Max Power
8/8/8/8 (Full Swing)	mA	2850	5000	1514	1826	507	514	561	603	30	35		
	Watts	2.85	5.50	1.51	2.01	1.27	1.41	0.56	0.66	0.10	0.12	6.29	9.71
8/8/8/8 (Half Swing)	mA	2850	5000	1302	1571	507	514	292	313	30	35		
	Watts	2.85	5.50	1.30	1.73	1.27	1.41	0.29	0.34	0.10	0.12	5.81	9.11

Table 16 PES32T8G2 Power Consumption — 3.3V I/O

Note 1: I/O supply of 3.3V is preferred.

Note 2: The above power consumption assumes that all ports are functioning at Gen2 (5.0 GT/S) speeds. Power consumption can be reduced by turning off unused ports through software or through boot EEPROM. Power savings will occur in V_{DDPEA} , V_{DDPEHA} , and V_{DDPETA} . Power savings can be estimated as directly proportional to the number of unused ports, since the power consumption of a turned-off port is close to zero. For example, if 2 ports out of 8 are turned off, then the power savings for each of the above three power rails can be calculated quite simply as 2/8 multiplied by the power consumption indicated in the above table.

Note 3: Using a port in Gen1 mode (2.5GT/S) results in approximately 18% power savings for each power rail: V_{DDPEA} , V_{DDPEHA} , and V_{DDPETA} .

Thermal Considerations

This section describes thermal considerations for the PES32T8G2 (23mm² FCBGA484 package). The data in Table 17 below contains information that is relevant to the thermal performance of the PES32T8G2 switch.

Symbol	Parameter	Value	Units	Conditions
$T_{J(max)}$	Junction Temperature	125	°C	Maximum
$T_{A(max)}$	Ambient Temperature	70	°C	Maximum for commercial-rated products
		85	°C	Maximum for industrial-rated products
$\theta_{JA(effective)}$	Effective Thermal Resistance, Junction-to-Ambient	15.2	°C/W	Zero air flow
		8.5	°C/W	1 m/S air flow
		7.1	°C/W	2 m/S air flow
θ_{JB}	Thermal Resistance, Junction-to-Board	3.1	°C/W	
θ_{JC}	Thermal Resistance, Junction-to-Case	0.15	°C/W	
P	Power Dissipation of the Device	9.71	Watts	Maximum

Table 17 Thermal Specifications for PES32T8G2, 23x23 mm FCBGA484 Package

Note: It is important for the reliability of this device in any user environment that the junction temperature not exceed the $T_{J(max)}$ value specified in Table 17. Consequently, the effective junction to ambient thermal resistance (θ_{JA}) for the worst case scenario must be maintained below the value determined by the formula:

$$\theta_{JA} = (T_{J(max)} - T_{A(max)})/P$$

Given that the values of $T_{J(max)}$, $T_{A(max)}$, and P are known, the value of desired θ_{JA} becomes a known entity to the system designer. How to achieve the desired θ_{JA} is left up to the board or system designer, but in general, it can be achieved by adding the effects of θ_{JC} (value provided in Table 17), thermal resistance of the chosen adhesive (θ_{CS}), that of the heat sink (θ_{SA}), amount of airflow, and properties of the circuit board (number of layers and size of the board). It is strongly recommended that users perform their own thermal analysis for their own board and system design scenarios.

DC Electrical Characteristics

Values based on systems running at recommended supply voltages, as shown in Table 13.

Note: See Table 8, Pin Characteristics, for a complete I/O listing.

I/O Type	Parameter	Description	Gen1			Gen2			Unit	Condi- tions
			Min ¹	Typ ¹	Max ¹	Min ¹	Typ ¹	Max ¹		
Serial Link	PCIe Transmit									
	V _{TX-DIFFp-p}	Differential peak-to-peak output voltage	800		1200	800		1200	mV	
	V _{TX-DIFFp-p-LOW}	Low-Drive Differential Peak to Peak Output Voltage	400		1200	400		1200	mV	
	V _{TX-DE-RATIO-3.5dB}	De-emphasized differential output voltage	-3		-4	-3.0	-3.5	-4.0	dB	
	V _{TX-DE-RATIO-6.0dB}	De-emphasized differential output voltage	NA			-5.5	-6.0	-6.5	dB	
	V _{TX-DC-CM}	DC Common mode voltage	0		3.6	0		3.6	V	
	V _{TX-CM-ACP}	RMS AC peak common mode output voltage			20				mV	
	V _{TX-CM-DC-active-idle-delta}	Abs delta of DC common mode voltage between L0 and idle			100			100	mV	
	V _{TX-CM-DC-line-delta}	Abs delta of DC common mode voltage between D+ and D-			25			25	mV	
	V _{TX-Idle-DiffP}	Electrical idle diff peak output			20			20	mV	
	RL _{TX-DIFF}	Transmitter Differential Return loss	10					10	dB	0.05 - 1.25GHz
									8	dB
	RL _{TX-CM}	Transmitter Common Mode Return loss	6					6	dB	
	Z _{TX-DIFF-DC}	DC Differential TX impedance	80	100	120			120	Ω	
	V _{TX-CM-ACpp}	Peak-Peak AC Common	NA					100	mV	
	V _{TX-DC-CM}	Transmit Driver DC Common Mode Voltage	0		3.6	0		3.6	V	
V _{TX-RCV-DETECT}	The amount of voltage change allowed during Receiver Detection			600			600	mV		
I _{TX-SHORT}	Transmitter Short Circuit Current Limit	0		90				90	mA	

Table 18 DC Electrical Characteristics (Part 1 of 2)

I/O Type	Parameter	Description	Gen1			Gen2			Unit	Conditions
			Min ¹	Typ ¹	Max ¹	Min ¹	Typ ¹	Max ¹		
Serial Link (cont.)	PCIe Receive									
	V _{RX-DIFFp-p}	Differential input voltage (peak-to-peak)	175		1200	120		1200	mV	
	RL _{RX-DIFF}	Receiver Differential Return Loss	10					10	dB	0.05 - 1.25GHz
								8		1.25 - 2.5GHz
	RL _{RX-CM}	Receiver Common Mode Return Loss	6					6	dB	
	Z _{RX-DIFF-DC}	Differential input impedance (DC)	80	100	120	Refer to return loss spec			Ω	
	Z _{RX--DC}	DC common mode impedance	40	50	60	40		60	Ω	
	Z _{RX-COMM-DC}	Powered down input common mode impedance (DC)	200k	350k				50k	Ω	
	Z _{RX-HIGH-IMP-DC-POS}	DC input CM input impedance for V>0 during reset or power down			50k			50k	Ω	
	Z _{RX-HIGH-IMP-DC-NEG}	DC input CM input impedance for V<0 during reset or power down			1.0k			1.0k	Ω	
V _{RX-IDLE-DET-DIFFp-p}	Electrical idle detect threshold	65		175	65		175	mV		
V _{RX-CM-ACp}	Receiver AC common-mode peak voltage			150			150	mV	V _{RX-CM-ACp}	
PCIe REFCLK										
	C _{IN}	Input Capacitance	1.5	—		1.5	—		pF	
Other I/Os										
LOW Drive Output	I _{OL}		—	2.5	—	—	2.5	—	mA	V _{OL} = 0.4v
	I _{OH}		—	-5.5	—	—	-5.5	—	mA	V _{OH} = 1.5V
High Drive Output	I _{OL}		—	12.0	—	—	12.0	—	mA	V _{OL} = 0.4v
	I _{OH}		—	-20.0	—	—	-20.0	—	mA	V _{OH} = 1.5V
Schmitt Trigger Input (STI)	V _{IL}		-0.3	—	0.8	-0.3	—	0.8	V	—
	V _{IH}		2.0	—	V _{DD} /O + 0.5	2.0	—	V _{DD} /O + 0.5	V	—
Input	V _{IL}		-0.3	—	0.8	-0.3	—	0.8	V	—
	V _{IH}		2.0	—	V _{DD} /O + 0.5	2.0	—	V _{DD} /O + 0.5	V	—
Capacitance	C _{IN}		—	—	8.5	—	—	8.5	pF	—
Leakage	Inputs		—	—	± 10	—	—	± 10	μA	V _{DD} /O (max)
	I/O _{LEAK} W/O Pull-ups/downs		—	—	± 10	—	—	± 10	μA	V _{DD} /O (max)
	I/O _{LEAK} WITH Pull-ups/downs		—	—	± 80	—	—	± 80	μA	V _{DD} /O (max)

Table 18 DC Electrical Characteristics (Part 2 of 2)

¹ Minimum, Typical, and Maximum values meet the requirements under PCI Specification 2.0.

Absolute Maximum Voltage Rating

Core Supply	PCIe Analog Supply	PCIe Analog High Supply	PCIe Transmitter Supply	I/O Supply
1.5V	1.5V	4.6V	1.5V	4.6V

Table 19 PES32T8G2 Absolute Maximum Voltage Rating

Warning: For proper and reliable operation in adherence with this data sheet, the device should not exceed the recommended operating voltages in Table 13. The absolute maximum operating voltages in Table 19 are offered to provide guidelines for voltage excursions outside the recommended voltage ranges. Device functionality is not guaranteed at these conditions and sustained operation at these values or any exposure to voltages outside the maximum range may adversely affect device functionality and reliability.

SMBus Characterization

Symbol	Parameter	SMBus 2.0 Char. Data ¹			Unit
		3V	3.3V	3.6V	
DC Parameter for SDA Pin					
V _{IL}	Input Low	1.16	1.26	1.35	V
V _{IH}	Input High	1.56	1.67	1.78	V
V _{OL@350uA}	Output Low	15	15	15	mV
I _{OL@0.4V}		23	24	25	mA
I _{Pullup}	Current Source	—	—	—	μA
I _{IL_Leak}	Input Low Leakage	0	0	0	μA
I _{IH_Leak}	Input High Leakage	0	0	0	μA
DC Parameter for SCL Pin					
V _{IL (V)}	Input Low	1.11	1.2	1.31	V
V _{IH (V)}	Input High	1.54	1.65	1.76	V
I _{IL_Leak}	Input Low Leakage	0	0	0	μA
I _{IH_Leak}	Input High Leakage	0	0	0	μA

Table 20 SMBus DC Characterization Data

¹ Data at room and hot temperature.

Symbol	Parameter	SMBus @3.3V $\pm 10\%$ ¹		Unit
		Min	Max	
F _{SCL}	Clock frequency	5	600	KHz
T _{BUF}	Bus free time between Stop and Start	3.5	—	μ s
T _{HD:STA}	Start condition hold time	1	—	μ s
T _{SU:STA}	Start condition setup time	1	—	μ s
T _{SU:STO}	Stop condition setup time	1	—	μ s
T _{HD:DAT}	Data hold time	1	—	ns
T _{SU:DAT}	Data setup time	1	—	ns
T _{TIMEOUT}	Detect clock low time out	—	74.7	ms
T _{LOW}	Clock low period	3.7	—	μ s
T _{HIGH}	Clock high period	3.7	—	μ s
T _F	Clock/Data fall time	—	72.2	ns
T _R	Clock/Data rise time	—	68.3	ns
T _{POR@10kHz}	Time which a device must be operational after power-on reset	20	—	ms

Table 21 SMBus AC Timing Data

¹. Data at room and hot temperature.

Package Pinout — 484-BGA Signal Pinout

The following table lists the pin numbers and signal names for the PES32T8G2 device.

Pin	Function	Alt	Pin	Function	Alt	Pin	Function	Alt	Pin	Function	Alt
A1	V _{SS}		B13	V _{SS}		D3	V _{SS}		E15	V _{DD} PEA	
A2	V _{DD} I/O		B14	V _{SS}		D4	V _{SS}		E16	V _{SS}	
A3	PE03TP3		B15	V _{SS}		D5	PE03RP3		E17	PE02RP1	
A4	PE03TP2		B16	PE02TN1		D6	PE03RN2		E18	V _{DD} PEHA	
A5	V _{SS}		B17	PE02TN0		D7	V _{SS}		E19	V _{SS}	
A6	PE03TP1		B18	V _{DD} I/O		D8	PE03RP1		E20	V _{SS}	
A7	PE03TP0		B19	MSMBCLK		D9	V _{SS}		E21	PE00TN0	
A8	V _{SS}		B20	JTAG_TMS		D10	PE03RP0		E22	PE00TP0	
A9	GCLKP0		B21	SSMBCLK		D11	REFRESPLL		F1	V _{SS}	
A10	V _{SS}		B22	JTAG_TCK		D12	V _{SS}		F2	V _{SS}	
A11	PE02TP3		C1	V _{SS}		D13	PE02RP3		F3	PE05RN3	
A12	PE02TP2		C2	V _{DD} I/O		D14	V _{SS}		F4	PE05RP3	
A13	V _{SS}		C3	V _{SS}		D15	PE02RP2		F5	V _{DD} PEHA	
A14	V _{SS}		C4	V _{SS}		D16	V _{SS}		F6	V _{DD} PEHA	
A15	V _{SS}		C5	PE03RN3		D17	PE02RN1		F7	V _{DD} PEHA	
A16	PE02TP1		C6	V _{SS}		D18	PE02RP0		F8	V _{DD} PEA	
A17	PE02TP0		C7	V _{SS}		D19	V _{SS}		F9	V _{DD} PETA	
A18	V _{DD} I/O		C8	PE03RN1		D20	JTAG_TDI		F10	V _{DD} PEA	
A19	MSMBDAT		C9	V _{SS}		D21	V _{DD} I/O		F11	V _{DD} PEA	
A20	JTAG_TDO		C10	PE03RN0		D22	V _{DD} I/O		F12	V _{DD} PETA	
A21	CLKMODE1		C11	V _{SS}		E1	V _{SS}		F13	V _{DD} PETA	
A22	SSMBADDR2		C12	V _{SS}		E2	V _{SS}		F14	V _{DD} PEA	
B1	V _{SS}		C13	PE02RN3		E3	V _{SS}		F15	V _{DD} PEA	
B2	V _{DD} I/O		C14	V _{SS}		E4	V _{SS}		F16	V _{DD} PEA	
B3	PE03TN3		C15	PE02RN2		E5	V _{DD} PEHA		F17	V _{DD} PEHA	
B4	PE03TN2		C16	REFRES02		E6	PE03RP2		F18	V _{DD} PEHA	
B5	V _{SS}		C17	V _{SS}		E7	V _{DD} PEA		F19	V _{DD} PEHA	
B6	PE03TN1		C18	PE02RN0		E8	V _{DD} PEA		F20	V _{SS}	
B7	PE03TN0		C19	PERSTN		E9	V _{DD} PETA		F21	PE00TN1	
B8	V _{SS}		C20	JTAG_TRST_N		E10	V _{DD} PEA		F22	PE00TP1	
B9	GCLKN0		C21	SSMBDAT		E11	REFRES03		G1	PE05TP3	
B10	V _{SS}		C22	SSMBADDR1		E12	V _{DD} PETA		G2	PE05TN3	
B11	PE02TN3		D1	V _{SS}		E13	NC		G3	V _{SS}	
B12	PE02TN2		D2	V _{SS}		E14	V _{SS}		G4	PE05RN2	

Table 22 PES32T8G2 Signal Pin-Out (Part 1 of 4)

Pin	Function	Alt	Pin	Function	Alt	Pin	Function	Alt	Pin	Function	Alt
G5	PE05RP2		H20	V _{SS}		K13	V _{SS}		M6	V _{DD} PEA	
G6	V _{DD} PEA		H21	V _{SS}		K14	V _{DD} CORE		M7	V _{SS}	
G7	V _{SS}		H22	V _{SS}		K15	V _{DD} CORE		M8	V _{DD} CORE	
G8	V _{DD} CORE		J1	V _{SS}		K16	V _{SS}		M9	V _{DD} CORE	
G9	V _{DD} CORE		J2	V _{SS}		K17	V _{DD} PETA		M10	V _{SS}	
G10	V _{SS}		J3	PE05RN1		K18	REFRES01		M11	V _{DD} CORE	
G11	V _{DD} CORE		J4	PE05RP1		K19	PE00RP2		M12	V _{DD} CORE	
G12	V _{DD} CORE		J5	V _{DD} PETA		K20	PE00RN2		M13	V _{SS}	
G13	V _{SS}		J6	V _{DD} PETA		K21	V _{SS}		M14	V _{DD} CORE	
G14	V _{DD} CORE		J7	V _{SS}		K22	V _{SS}		M15	V _{DD} CORE	
G15	V _{DD} CORE		J8	V _{DD} CORE		L1	PE05TP0		M16	V _{SS}	
G16	V _{SS}		J9	V _{DD} CORE		L2	PE05TN0		M17	V _{DD} PEA	
G17	V _{DD} PEA		J10	V _{SS}		L3	V _{SS}		M18	V _{DD} PEA	
G18	V _{DD} PEA		J11	V _{DD} CORE		L4	V _{SS}		M19	V _{SS}	
G19	PE00RP0		J12	V _{DD} CORE		L5	V _{DD} PEA		M20	V _{SS}	
G20	PE00RN0		J13	V _{SS}		L6	V _{DD} PEA		M21	PE00TN3	
G21	V _{SS}		J14	V _{DD} CORE		L7	V _{SS}		M22	PE00TP3	
G22	V _{SS}		J15	V _{DD} CORE		L8	V _{DD} CORE		N1	PE04TP3	
H1	PE05TP2		J16	V _{SS}		L9	V _{DD} CORE		N2	PE04TN3	
H2	PE05TN2		J17	V _{DD} PETA		L10	V _{SS}		N3	REFRES04	
H3	REFRES05		J18	V _{DD} PETA		L11	V _{DD} CORE		N4	PE04RN2	
H4	V _{SS}		J19	REFRES00		L12	V _{DD} CORE		N5	PE04RP2	
H5	V _{DD} PEA		J20	NC		L13	V _{SS}		N6	V _{DD} PEA	
H6	V _{DD} PEA		J21	V _{SS}		L14	V _{DD} CORE		N7	V _{SS}	
H7	V _{SS}		J22	V _{SS}		L15	V _{DD} CORE		N8	V _{DD} CORE	
H8	V _{DD} CORE		K1	PE05TP1		L16	V _{SS}		N9	V _{DD} CORE	
H9	V _{DD} CORE		K2	PE05TN1		L17	V _{DD} PEA		N10	V _{SS}	
H10	V _{SS}		K3	V _{SS}		L18	PE00RP3		N11	V _{DD} CORE	
H11	V _{DD} CORE		K4	PE05RN0		L19	PE00RN3		N12	V _{DD} CORE	
H12	V _{DD} CORE		K5	PE05RP0		L20	V _{SS}		N13	V _{SS}	
H13	V _{SS}		K6	V _{DD} PETA		L21	PE00TN2		N14	V _{DD} CORE	
H14	V _{DD} CORE		K7	V _{SS}		L22	PE00TP2		N15	V _{DD} CORE	
H15	V _{DD} CORE		K8	V _{DD} CORE		M1	V _{SS}		N16	V _{SS}	
H16	V _{SS}		K9	V _{DD} CORE		M2	V _{SS}		N17	V _{DD} PEA	
H17	V _{DD} PEA		K10	V _{SS}		M3	PE04RN3		N18	V _{DD} PEA	
H18	PE00RP1		K11	V _{DD} CORE		M4	PE04RP3		N19	PE01RP0	
H19	PE00RN1		K12	V _{DD} CORE		M5	V _{DD} PEA		N20	PE01RN0	

Table 22 PES32T8G2 Signal Pin-Out (Part 2 of 4)

Pin	Function	Alt	Pin	Function	Alt	Pin	Function	Alt	Pin	Function	Alt
N21	V _{SS}		R14	V _{DD} CORE		U7	V _{DD} PEA		V22	PE01TP3	
N22	V _{SS}		R15	V _{DD} CORE		U8	V _{DD} PEA		W1	V _{SS}	
P1	PE04TP2		R16	V _{SS}		U9	V _{DD} PEA		W2	P23MERGEN	
P2	PE04TN2		R17	V _{DD} PETA		U10	V _{DD} PETA		W3	P45MERGEN	
P3	V _{SS}		R18	V _{DD} PETA		U11	V _{DD} PETA		W4	V _{DD} I/O	
P4	V _{SS}		R19	V _{SS}		U12	V _{DD} PEA		W5	PE06RP0	
P5	V _{DD} PETA		R20	V _{SS}		U13	V _{DD} PEA		W6	PE06RN1	
P6	V _{DD} PETA		R21	PE01TN1		U14	V _{DD} PEA		W7	REFRES06	
P7	V _{SS}		R22	PE01TP1		U15	V _{DD} PETA		W8	PE06RP2	
P8	V _{DD} CORE		T1	PE04TP1		U16	V _{DD} PEA		W9	V _{SS}	
P9	V _{DD} CORE		T2	PE04TN1		U17	V _{DD} PEHA		W10	V _{SS}	
P10	V _{SS}		T3	V _{SS}		U18	PE01RP3		W11	PE06RP3	
P11	V _{DD} CORE		T4	V _{SS}		U19	PE01RN3		W12	V _{SS}	
P12	V _{DD} CORE		T5	V _{DD} PEHA		U20	V _{SS}		W13	PE07RP0	
P13	V _{SS}		T6	V _{DD} PEHA		U21	PE01TN2		W14	PE07RN1	
P14	V _{DD} CORE		T7	V _{SS}		U22	PE01TP2		W15	V _{SS}	
P15	V _{DD} CORE		T8	V _{DD} CORE		V1	V _{DD} I/O		W16	PE07RP2	
P16	V _{SS}		T9	V _{DD} CORE		V2	V _{DD} I/O		W17	V _{SS}	
P17	V _{DD} PEA		T10	V _{SS}		V3	PE04RN0		W18	V _{DD} PEHA	
P18	PE01RP1		T11	V _{DD} CORE		V4	PE04RP0		W19	PE07RP3	
P19	PE01RN1		T12	V _{DD} CORE		V5	V _{SS}		W20	V _{DD} I/O	
P20	V _{SS}		T13	V _{SS}		V6	PE06RP1		W21	V _{DD} I/O	
P21	PE01TN0		T14	V _{DD} CORE		V7	V _{SS}		W22	V _{DD} I/O	
P22	PE01TP0		T15	V _{DD} CORE		V8	V _{DD} PEA		Y1	P01MERGEN	
R1	V _{SS}		T16	V _{SS}		V9	V _{DD} PEA		Y2	P67MERGEN	
R2	V _{SS}		T17	V _{DD} PETA		V10	V _{SS}		Y3	V _{SS}	
R3	PE04RN1		T18	V _{DD} PETA		V11	V _{DD} PETA		Y4	V _{SS}	
R4	PE04RP1		T19	PE01RP2		V12	V _{SS}		Y5	PE06RN0	
R5	V _{DD} PETA		T20	PE01RN2		V13	V _{DD} PEA		Y6	V _{SS}	
R6	V _{DD} PETA		T21	V _{SS}		V14	PE07RP1		Y7	V _{SS}	
R7	V _{SS}		T22	V _{SS}		V15	V _{DD} PETA		Y8	PE06RN2	
R8	V _{DD} CORE		U1	PE04TP0		V16	V _{DD} PEA		Y9	V _{SS}	
R9	V _{DD} CORE		U2	PE04TN0		V17	V _{DD} PEHA		Y10	V _{SS}	
R10	V _{SS}		U3	V _{SS}		V18	V _{DD} PEHA		Y11	PE06RN3	
R11	V _{DD} CORE		U4	V _{SS}		V19	V _{SS}		Y12	V _{SS}	
R12	V _{DD} CORE		U5	V _{DD} PEHA		V20	V _{SS}		Y13	PE07RN0	
R13	V _{SS}		U6	V _{DD} PEHA		V21	PE01TN3		Y14	V _{SS}	

Table 22 PES32T8G2 Signal Pin-Out (Part 3 of 4)

Pin	Function	Alt	Pin	Function	Alt	Pin	Function	Alt	Pin	Function	Alt
Y15	REFRES07		AA6	PE06TN0		AA19	V _{SS}		AB10	PE06TP3	
Y16	PE07RN2		AA7	PE06TN1		AA20	GPIO_03		AB11	V _{SS}	
Y17	V _{SS}		AA8	V _{SS}		AA21	GPIO_04	1	AB12	GCLKP1	
Y18	V _{SS}		AA9	PE06TN2		AA22	GPIO_05	2	AB13	V _{SS}	
Y19	PE07RN3		AA10	PE06TN3		AB1	SWMODE1		AB14	PE07TP0	
Y20	GPIO_06		AA11	V _{SS}		AB2	RSTHALT		AB15	PE07TP1	
Y21	GPIO_07		AA12	GCLKN1		AB3	SWMODE2		AB16	V _{SS}	
Y22	GPIO_08	1	AA13	V _{SS}		AB4	SWMODE3		AB17	PE07TP2	
AA1	CLKMODE0		AA14	PE07TN0		AB5	V _{DD} I/O		AB18	PE07TP3	
AA2	GCLKFSEL		AA15	PE07TN1		AB6	PE06TP0		AB19	V _{SS}	
AA3	SWMODE0		AA16	V _{SS}		AB7	PE06TP1		AB20	GPIO_00	
AA4	V _{SS}		AA17	PE07TN2		AB8	V _{SS}		AB21	GPIO_01	
AA5	V _{DD} I/O		AA18	PE07TN3		AB9	PE06TP2		AB22	GPIO_02	

Table 22 PES32T8G2 Signal Pin-Out (Part 4 of 4)

Alternate Signal Functions

Pin	GPIO	1st Alternate	2nd Alternate
AA21	GPIO_04	—	POLINKUPN
AA22	GPIO_05	GPEN	POACTIVEN
Y22	GPIO_08	IOEXPINTN	—

Table 23 PES32T8G2 Alternate Signal Functions

No Connection Pins

NC	
E13	J20

Table 24 PES32T8G2 No Connection

Power Pins

V _{DD} Core	V _{DD} Core	V _{DD} Core	V _{DD} IO	V _{DD} PEA	V _{DD} PEA	V _{DD} PEHA	V _{DD} PETA
G8	K11	N14	A2	E7	M5	E5	E9
G9	K12	N15	A18	E8	M6	E18	E12
G11	K14	P8	B2	E10	M17	F5	F9
G12	K15	P9	B18	E15	M18	F6	F12
G14	L8	P11	C2	F8	N6	F7	F13
G15	L9	P12	D21	F10	N17	F17	J5
H8	L11	P14	D22	F11	N18	F18	J6
H9	L12	P15	V1	F14	P17	F19	J17
H11	L14	R8	V2	F15	U7	T5	J18
H12	L15	R9	W4	F16	U8	T6	K6
H14	M8	R11	W20	G6	U9	U5	K17
H15	M9	R12	W21	G17	U12	U6	P5
J8	M11	R14	W22	G18	U13	U17	P6
J9	M12	R15	AA5	H5	U14	V17	R5
J11	M14	T8	AB5	H6	U16	V18	R6
J12	M15	T9		H17	V8	W18	R17
J14	N8	T11		L5	V9		R18
J15	N9	T12		L6	V13		T17
K8	N11	T14		L17	V16		T18
K9	N12	T15					U10
							U11
							U15
							V11
							V15

Table 25 PES32T8G2 Power Pins

Ground Pins

V _{SS}	V _{SS}	V _{SS}	V _{SS}	V _{SS}	V _{SS}
A1	D3	H4	L10	R2	W10
A5	D4	H7	L13	R7	W12
A8	D7	H10	L16	R10	W15
A10	D9	H13	L20	R13	W17
A13	D12	H16	M1	R16	Y3
A14	D14	H20	M2	R19	Y4
A15	D16	H21	M7	R20	Y6
B1	D19	H22	M10	T3	Y7
B5	E1	J1	M13	T4	Y9
B8	E2	J2	M16	T7	Y10
B10	E3	J7	M19	T10	Y12
B13	E4	J10	M20	T13	Y14
B14	E14	J13	N7	T16	Y17
B15	E16	J16	N10	T21	Y18
C1	E19	J21	N13	T22	AA4
C3	E20	J22	N16	U3	AA8
C4	F1	K3	N21	U4	AA11
C6	F2	K7	N22	U20	AA13
C7	F20	K10	P3	V5	AA16
C9	G3	K13	P4	V7	AA19
C11	G7	K16	P7	V10	AB8
C12	G10	K21	P10	V12	AB11
C14	G13	K22	P13	V19	AB13
C17	G16	L3	P16	V20	AB16
D1	G21	L4	P20	W1	AB19
D2	G22	L7	R1	W9	—

Table 26 PES32T8G2 Ground Pins

Signals Listed Alphabetically

Signal Name	I/O Type	Location	Signal Category
CLKMODE0	I	AA1	System
CLKMODE1	I	A21	
GCLKFSEL	I	AA2	
GCLKN0	I	B9	PCI Express
GCLKN1	I	AA12	
GCLKP0	I	A9	
GCLKP1	I	AB12	
GPIO_00	I/O	AB20	General Purpose Input/Output
GPIO_01	I/O	AB21	
GPIO_02	I/O	AB22	
GPIO_03	I/O	AA20	
GPIO_04	I/O	AA21	
GPIO_05	I/O	AA22	
GPIO_06	I/O	Y20	
GPIO_07	I/O	Y21	
GPIO_08	I/O	Y22	
JTAG_TCK	I	B22	JTAG
JTAG_TDI	I	D20	
JTAG_TDO	O	A20	
JTAG_TMS	I	B20	
JTAG_TRST_N	I	C20	
MSMBCLK	I/O	B19	SMBus
MSMBDAT	I/O	A19	
NO CONNECTION		See Table 24 for a listing of No Connect pins.	
P01MERGEN	I	Y1	System
P23MERGEN	I	W2	
P45MERGEN	I	W3	
P67MERGEN	I	Y2	

Table 27 PES32T8G2 Alphabetical Signal List (Part 1 of 6)

Signal Name	I/O Type	Location	Signal Category
PE00RN0	I	G20	PCI Express
PE00RN1	I	H19	
PE00RN2	I	K20	
PE00RN3	I	L19	
PE00RP0	I	G19	
PE00RP1	I	H18	
PE00RP2	I	K19	
PE00RP3	I	L18	
PE00TN0	O	E21	
PE00TN1	O	F21	
PE00TN2	O	L21	
PE00TN3	O	M21	
PE00TP0	O	E22	
PE00TP1	O	F22	
PE00TP2	O	L22	
PE00TP3	O	M22	
PE01RN0	I	N20	
PE01RN1	I	P19	
PE01RN2	I	T20	
PE01RN3	I	U19	
PE01RP0	I	N19	
PE01RP1	I	P18	
PE01RP2	I	T19	
PE01RP3	I	U18	
PE01TN0	O	P21	
PE01TN1	O	R21	
PE01TN2	O	U21	
PE01TN3	O	V21	
PE01TP0	O	P22	
PE01TP1	O	R22	
PE01TP2	O	U22	
PE01TP3	O	V22	
PE02RN0	I	C18	
PE02RN1	I	D17	
PE02RN2	I	C15	
PE02RN3	I	C13	

Table 27 PES32T8G2 Alphabetical Signal List (Part 2 of 6)

Signal Name	I/O Type	Location	Signal Category
PE02RP0	I	D18	PCI Express (Cont.)
PE02RP1	I	E17	
PE02RP2	I	D15	
PE02RP3	I	D13	
PE02TN0	O	B17	
PE02TN1	O	B16	
PE02TN2	O	B12	
PE02TN3	O	B11	
PE02TP0	O	A17	
PE02TP1	O	A16	
PE02TP2	O	A12	
PE02TP3	O	A11	
PE03RN0	I	C10	
PE03RN1	I	C8	
PE03RN2	I	D6	
PE03RN3	I	C5	
PE03RP0	I	D10	
PE03RP1	I	D8	
PE03RP2	I	E6	
PE03RP3	I	D5	
PE03TN0	O	B7	
PE03TN1	O	B6	
PE03TN2	O	B4	
PE03TN3	O	B3	
PE03TP0	O	A7	
PE03TP1	O	A6	
PE03TP2	O	A4	
PE03TP3	O	A3	
PE04RN0	I	V3	
PE04RN1	I	R3	
PE04RN2	I	N4	
PE04RN3	I	M3	
PE04RP0	I	V4	
PE04RP1	I	R4	
PE04RP2	I	N5	
PE04RP3	I	M4	

Table 27 PES32T8G2 Alphabetical Signal List (Part 3 of 6)

Signal Name	I/O Type	Location	Signal Category
PE04TN0	O	U2	PCI Express (Cont.)
PE04TN1	O	T2	
PE04TN2	O	P2	
PE04TN3	O	N2	
PE04TP0	O	U1	
PE04TP1	O	T1	
PE04TP2	O	P1	
PE04TP3	O	N1	
PE05RN0	I	K4	
PE05RN1	I	J3	
PE05RN2	I	G4	
PE05RN3	I	F3	
PE05RP0	I	K5	
PE05RP1	I	J4	
PE05RP2	I	G5	
PE05RP3	I	F4	
PE05TN0	O	L2	
PE05TN1	O	K2	
PE05TN2	O	H2	
PE05TN3	O	G2	
PE05TP0	O	L1	
PE05TP1	O	K1	
PE05TP2	O	H1	
PE05TP3	O	G1	
PE06RN0	I	Y5	
PE06RN1	I	W6	
PE06RN2	I	Y8	
PE06RN3	I	Y11	
PE06RP0	I	W5	
PE06RP1	I	V6	
PE06RP2	I	W8	
PE06RP3	I	W11	
PE06TN0	O	AA6	
PE06TN1	O	AA7	
PE06TN2	O	AA9	
PE06TN3	O	AA10	

Table 27 PES32T8G2 Alphabetical Signal List (Part 4 of 6)

Signal Name	I/O Type	Location	Signal Category
PE06TP0	O	AB6	PCI Express (Cont.)
PE06TP1	O	AB7	
PE06TP2	O	AB9	
PE06TP3	O	AB10	
PE07RN0	I	Y13	
PE07RN1	I	W14	
PE07RN2	I	Y16	
PE07RN3	I	Y19	
PE07RP0	I	W13	
PE07RP1	I	V14	
PE07RP2	I	W16	
PE07RP3	I	W19	
PE07TN0	O	AA14	
PE07TN1	O	AA15	
PE07TN2	O	AA17	
PE07TN3	O	AA18	
PE07TP0	O	AB14	
PE07TP1	O	AB15	
PE07TP2	O	AB17	
PE07TP3	O	AB18	
PERSTN	I	C19	System
REFRES00	I	J19	SerDes Reference Resistors
REFRES01	I	K18	
REFRES02	I	C16	
REFRES03	I	E11	
REFRES04	I	N3	
REFRES05	I	H3	
REFRES06	I	W7	
REFRES07	I	Y15	
REFRESPLL	I	D11	
RSTHALT	I	AB2	System
SSMBADDR1	I	C22	SMBus
SSMBADDR2	I	A22	
SSMBCLK	I/O	B21	
SSMBDAT	I/O	C21	

Table 27 PES32T8G2 Alphabetical Signal List (Part 5 of 6)

Signal Name	I/O Type	Location	Signal Category
SWMODE0	I	AA3	System
SWMODE1	I	AB1	
SWMODE2	I	AB3	
SWMODE3	I	AB4	
V_{DDCORE} , V_{DDPEA} , V_{DDIO} , V_{DDPE} , V_{TTPE}	See Table 25 for a listing of power pins.		
V_{SS}	See Table 26 for a listing of ground pins.		

Table 27 PES32T8G2 Alphabetical Signal List (Part 6 of 6)

PES32T8G2 Pinout — Top View

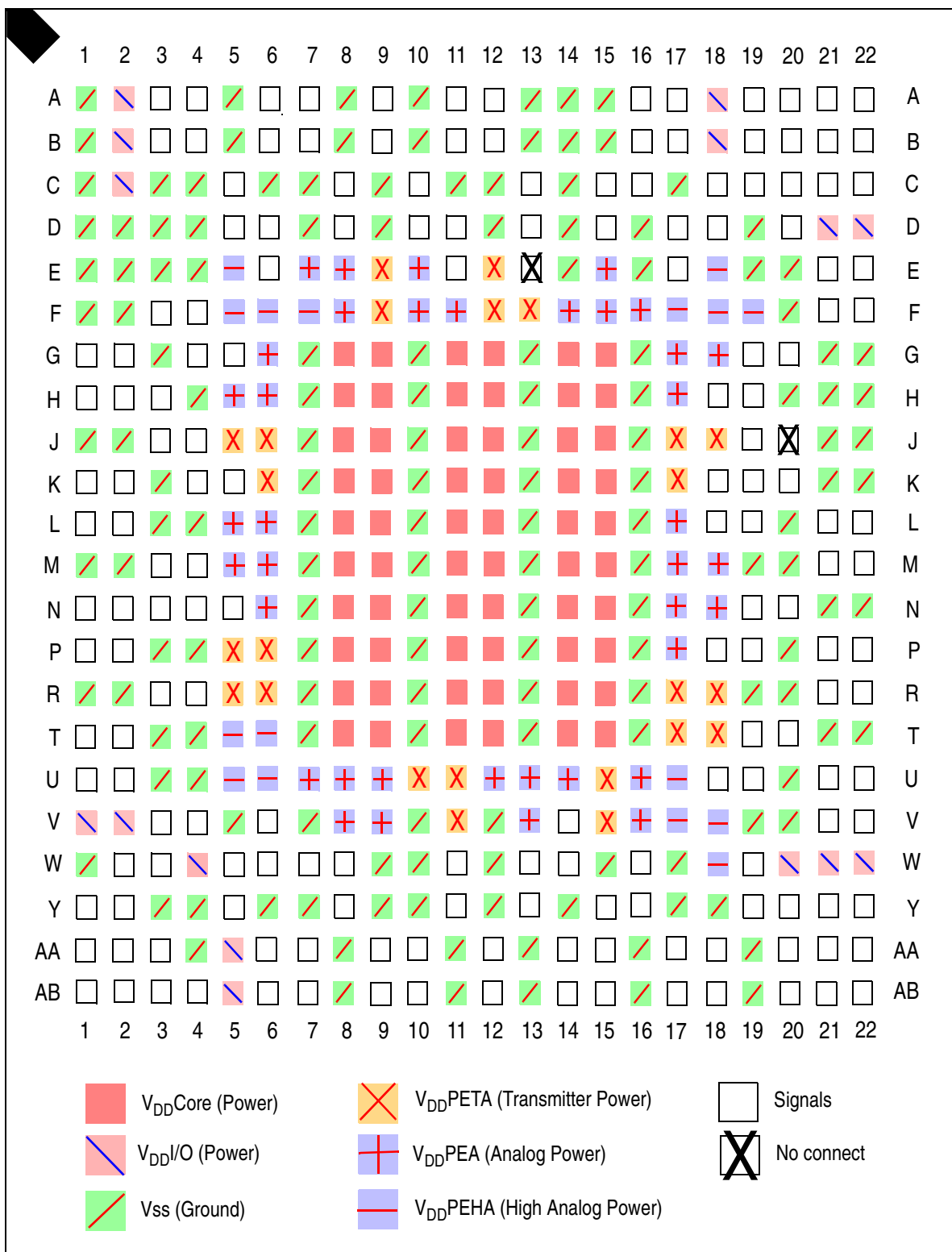

Revision History

January 21, 2010: Publication of Final data sheet.

March 30, 2011: In Table 13, added $V_{DD}PETA$ to footnote #1.

November 28, 2011: Added new Tables 20 and 21, SMBus Characterization and Timing.

Ordering Information

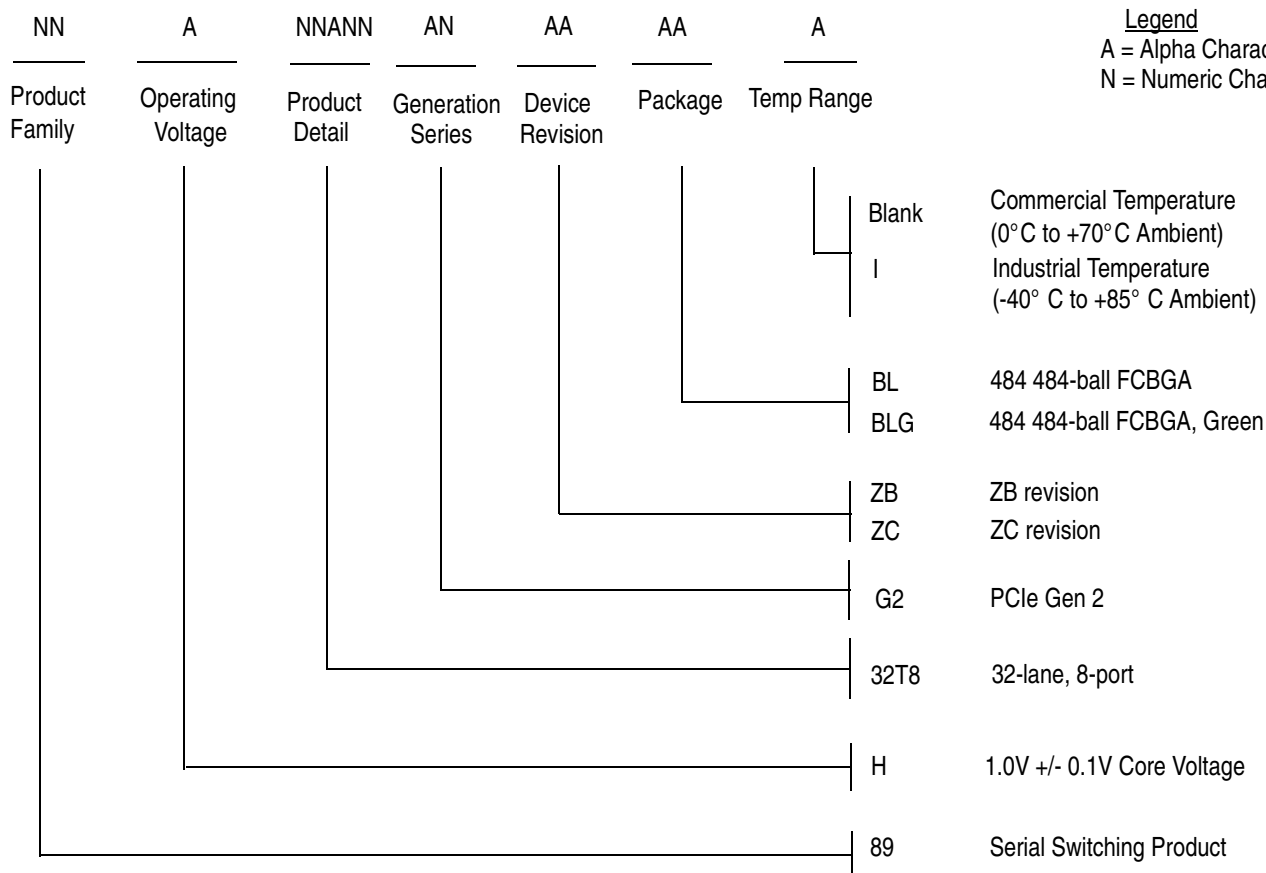

Legend
 A = Alpha Character
 N = Numeric Character

Valid Combinations

89H32T8G2ZBBL	484-ball FCBGA package, Commercial Temperature
89H32T8G2ZBBLG	484-ball Green FCBGA package, Commercial Temperature
89H32T8G2ZBBLI	484-ball FCBGA package, Industrial Temperature
89H32T8G2ZBBLGI	484-ball Green FCBGA package, Industrial Temperature
89H32T8G2ZCBL	484-ball FCBGA package, Commercial Temperature
89H32T8G2ZCBLG	484-ball Green FCBGA package, Commercial Temperature
89H32T8G2ZCBLI	484-ball FCBGA package, Industrial Temperature
89H32T8G2ZCBLGI	484-ball Green FCBGA package, Industrial Temperature



CORPORATE HEADQUARTERS
 6024 Silver Creek Valley Road
 San Jose, CA 95138

for SALES:
 800-345-7015 or 408-284-8200
 fax: 408-284-2775
www.idt.com

for Tech Support:
 email: ssdhelp@idt.com
 phone: 408-284-8208