



Low Skew, Dual, Differential-to-LVDS Fanout Buffer

ICS854S036

DATA SHEET

General Description



The ICS854S036 is a low skew, high performance Dual Differential-to-LVDS Fanout Buffer. One of the two fanout buffers has 3 LVDS outputs, the other has 6 LVDS outputs. The PCLKx, nPCLKx pairs can accept most standard differential input levels. The ICS854S036 is characterized to operate from a 3.3V power supply. Guaranteed output and bank skew characteristics make the ICS854S036 ideal for those clock distribution applications demanding well defined performance and repeatability.

Features

- Two independent differential LVDS output buffers, buffer A with three outputs, buffer B with 6 outputs
- Two differential clock input pairs
- PCLKx, nPCLKx pairs can accept the following differential input levels: LVPECL, LVDS, CML, SSTL
- Output frequency: 2GHz
- Translates any single ended input signal to LVDS levels with resistor bias on nPCLKx input
- Output skew: 100ps (maximum)
- Bank skew: 20ps (maximum)
- Propagation delay: 550ps (maximum)
- Additive phase jitter, RMS: 0.06ps (typical)
- Full 3.3V power supply
- 0°C to 70°C ambient operating temperature
- Available in lead-free (RoHS 6) package

Block Diagram

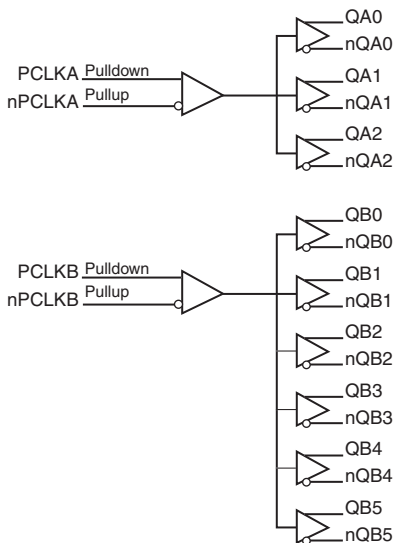

Pin Assignment

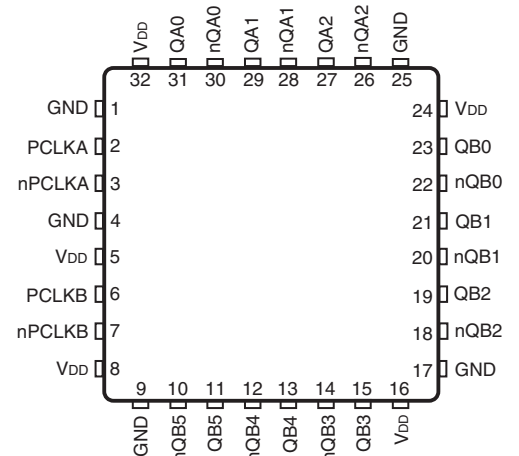

ICS854S036
32-Lead VFQFN
5mm x 5mm x 0.925mm package body
K Package
Top View

Table 1. Pin Descriptions

| Number | Name | Type | | Description |
|------------------|-----------------|--------|----------|--------------------------------------------------|
| 1, 4, 9, 17, 25 | GND | Power | | Power supply ground. |
| 2 | PCLKA | Input | Pulldown | Non-inverting differential clock input. |
| 3 | nPCLKA | Input | Pullup | Inverting differential clock input. |
| 5, 8, 16, 24, 32 | V _{DD} | Power | | Power supply pins. |
| 6 | PCLKB | Input | Pulldown | Non-inverting differential clock input. |
| 7 | nPCLKB | Input | Pullup | Inverting differential clock input. |
| 10, 11 | nQB5, QB5 | Output | | Differential output pair. LVDS interface levels. |
| 12, 13 | nQB4, QB4 | Output | | Differential output pair. LVDS interface levels. |
| 14, 15 | nQB3, QB3 | Output | | Differential output pair. LVDS interface levels. |
| 18, 19 | nQB2, QB2 | Output | | Differential output pair. LVDS interface levels. |
| 20, 21 | nQB1, QB1 | Output | | Differential output pair. LVDS interface levels. |
| 22, 23 | nQB0, QB0 | Output | | Differential output pair. LVDS interface levels. |
| 26, 27 | nQA2, QA2 | Output | | Differential output pair. LVDS interface levels. |
| 28, 29 | nQA1, QA1 | Output | | Differential output pair. LVDS interface levels. |
| 30, 31 | nQA0, QA0 | Output | | Differential output pair. LVDS interface levels. |

NOTE: *Pullup* and *Pulldown* refer to internal input resistors. See Table 2, *Pin Characteristics*, for typical values.

Table 2. Pin Characteristics

| Symbol | Parameter | Test Conditions | Minimum | Typical | Maximum | Units |
|-----------------------|-------------------------|-----------------|---------|---------|---------|-------|
| C _{IN} | Input Capacitance | | | 2 | | pF |
| R _{PULLUP} | Input Pullup Resistor | | | 51 | | kΩ |
| R _{PULLDOWN} | Input Pulldown Resistor | | | 51 | | kΩ |

Table 3. Clock Input Function Table

| Inputs | | Outputs | | Input to Output Mode | Polarity |
|----------------|----------------|------------------|--------------------|------------------------------|---------------|
| PCLKA, PCLKB | nPCLKA, nPCLKB | QA[0:2], QB[0:5] | nQA[0:2], nQB[0:5] | | |
| 0 | 1 | LOW | HIGH | Differential to Differential | Non-Inverting |
| 1 | 0 | HIGH | LOW | Differential to Differential | Non-Inverting |
| 0 | Biased; NOTE 1 | LOW | HIGH | Single-ended to Differential | Non-Inverting |
| 1 | Biased; NOTE 1 | HIGH | LOW | Single-ended to Differential | Non-Inverting |
| Biased; NOTE 1 | 0 | HIGH | LOW | Single-ended to Differential | Inverting |
| Biased; NOTE 1 | 1 | LOW | HIGH | Single-ended to Differential | Inverting |

NOTE 1: Refer to the Application Information Section, *Wiring the Differential Input to Accept Single-ended Levels*.

Absolute Maximum Ratings

NOTE: Stresses beyond those listed under *Absolute Maximum Ratings* may cause permanent damage to the device. These ratings are stress specifications only. Functional operation of product at these conditions or any conditions beyond those listed in the *DC Characteristics* or *AC Characteristics* is not implied. Exposure to absolute maximum rating conditions for extended periods may affect product reliability.

| Item | Rating |
|-------------------------------------------------------|--------------------------|
| Supply Voltage, V_{DD} | 4.6V |
| Inputs, V_I | -0.5V to $V_{DD} + 0.5V$ |
| Outputs, I_O Continuous Current Surge Current | 10mA 15mA |
| Package Thermal Impedance, θ_{JA} | 42.7°C/W (0 mps) |
| Storage Temperature, T_{STG} | -65°C to 150°C |

DC Electrical Characteristics

Table 4A. LVDS Power Supply DC Characteristics, $V_{DD} = 3.3V \pm 5\%$, $T_A = 0^\circ C$ to $70^\circ C$

| Symbol | Parameter | Test Conditions | Minimum | Typical | Maximum | Units |
|----------|-------------------------|-----------------|---------|---------|---------|-------|
| V_{DD} | Positive Supply Voltage | | 3.135 | 3.3 | 3.465 | V |
| I_{DD} | Power Supply Current | | | | 210 | mA |

Table 4B. LVPECL Differential DC Characteristics, $V_{DD} = 3.3V \pm 5\%$, $T_A = 0^\circ C$ to $70^\circ C$

| Symbol | Parameter | Test Conditions | Minimum | Typical | Maximum | Units | |
|-----------|--------------------------------------|-----------------|--------------------------------|---------|----------|-------|---------|
| I_{IH} | Input High Current | PCLKA, PCLKB | $V_{DD} = V_{IN} = 3.465V$ | | | 150 | μA |
| | | nPCLKA, nPCLKB | $V_{DD} = V_{IN} = 3.465V$ | | | 10 | μA |
| I_{IL} | Input Low Current | PCLKA, PCLKB | $V_{DD} = 3.465V, V_{IN} = 0V$ | -10 | | | μA |
| | | nPCLKA, nPCLKB | $V_{DD} = 3.465V, V_{IN} = 0V$ | -150 | | | μA |
| V_{PP} | Peak-to-Peak Voltage; NOTE 1 | | 0.25 | | 1.0 | V | |
| V_{CMR} | Common Mode Input Voltage; NOTE 1, 2 | | GND + 1.25 | | V_{DD} | V | |

NOTE 1: V_{IL} should not be less than -0.3V.

NOTE 2: Common mode input voltage is defined as V_{IH} .

Table 4C. LVDS DC Characteristics, $V_{DD} = 3.3V \pm 5\%$, $T_A = 0^\circ C$ to $70^\circ C$

| Symbol | Parameter | Test Conditions | Minimum | Typical | Maximum | Units |
|-----------------|-----------------------------|-----------------|---------|---------|---------|-------|
| V_{OD} | Differential Output Voltage | | 247 | | 454 | mV |
| ΔV_{OD} | V_{OD} Magnitude Change | | | | 50 | mV |
| V_{OS} | Offset Voltage | | 1.125 | | 1.375 | V |
| ΔV_{OS} | V_{OS} Magnitude Change | | | | 50 | mV |

Table 5. AC Characteristics, $V_{DD} = 3.3V \pm 5\%$, $T_A = 0^\circ C$ to $70^\circ C$

| Symbol | Parameter | Test Conditions | Minimum | Typical | Maximum | Units |
|-------------|---------------------------------------------------------------------------|---------------------------------------------|---------|---------|---------|-------|
| f_{OUT} | Output Frequency | | | | 2 | GHz |
| t_{PD} | Propagation Delay; NOTE 1 | | 300 | | 550 | ps |
| $tsk(o)$ | Output Skew; NOTE 2, 4 | | | | 100 | ps |
| $tsk(b)$ | Bank Skew; NOTE 3, 4 | | | | 20 | ps |
| f_{jit} | Buffer Additive Phase Jitter, RMS; refer to Additive Phase Jitter Section | 100MHz, Integration Range: 12kHz – 20MHz | | 0.06 | | ps |
| t_R / t_F | Output Rise/Fall Time | 20% to 80% | 100 | | 250 | ps |
| odc | Output Duty Cycle | | 48 | | 52 | % |

NOTE: Electrical parameters are guaranteed over the specified ambient operating temperature range, which is established when the device is mounted in a test socket with maintained transverse airflow greater than 500 lfm. The device will meet specifications after thermal equilibrium has been reached under these conditions.

All parameters measured at 500MHz unless noted otherwise.

NOTE 1: Measured from the differential input crossing point to the differential output crossing point.

NOTE 2: Defined as skew between outputs at the same supply voltage and with equal load conditions. Measured from the output differential cross points.

NOTE 3: Defined as skew within a bank of outputs at the same voltage and with equal load conditions.

NOTE 4: This parameter is defined in accordance with JEDEC Standard 65.

Additive Phase Jitter

The spectral purity in a band at a specific offset from the fundamental compared to the power of the fundamental is called the ***dBc Phase Noise***. This value is normally expressed using a Phase noise plot and is most often the specified plot in many applications. Phase noise is defined as the ratio of the noise power present in a 1Hz band at a specified offset from the fundamental frequency to the power value of the fundamental. This ratio is expressed in decibels (dBm) or a ratio

of the power in the 1Hz band to the power in the fundamental. When the required offset is specified, the phase noise is called a ***dBc*** value, which simply means dBm at a specified offset from the fundamental. By investigating jitter in the frequency domain, we get a better understanding of its effects on the desired application over the entire time record of the signal. It is mathematically possible to calculate an expected bit error rate given a phase noise plot.

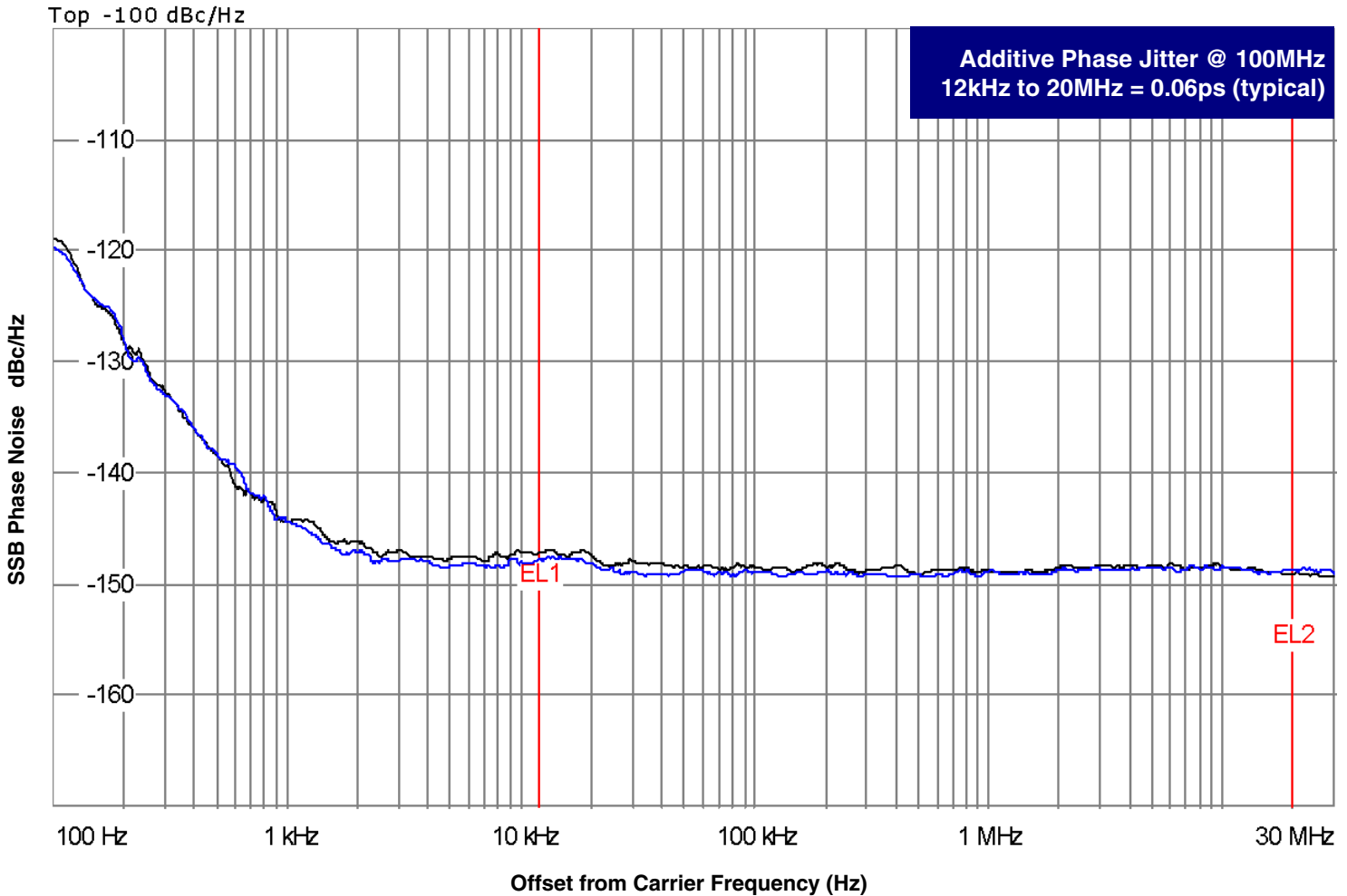

As with most timing specifications, phase noise measurements has issues relating to the limitations of the equipment. Often the noise floor of the equipment is higher than the noise floor of the device. This is illustrated above. The device meets the noise floor of what is shown, but can actually be lower. The phase noise is dependent on the input source and measurement equipment.

IFR2042 10kHz - 5.4GHz Low Noise Signal Generator as external input to a Hewlett Packard 8133A 3GHz Pulse Generator.

Parameter Measurement Information

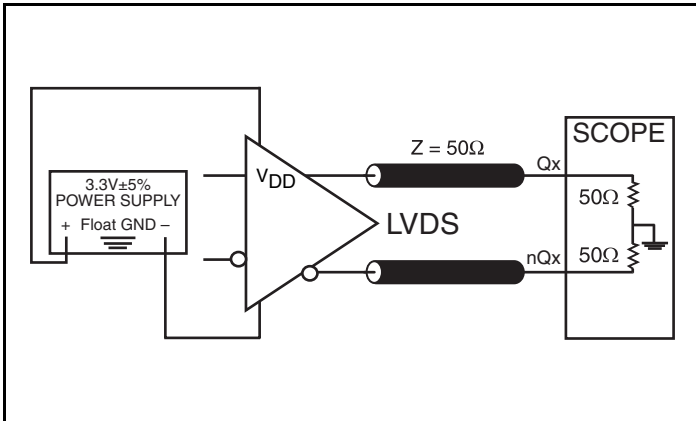

3.3V LVDS Output Load AC Test Circuit

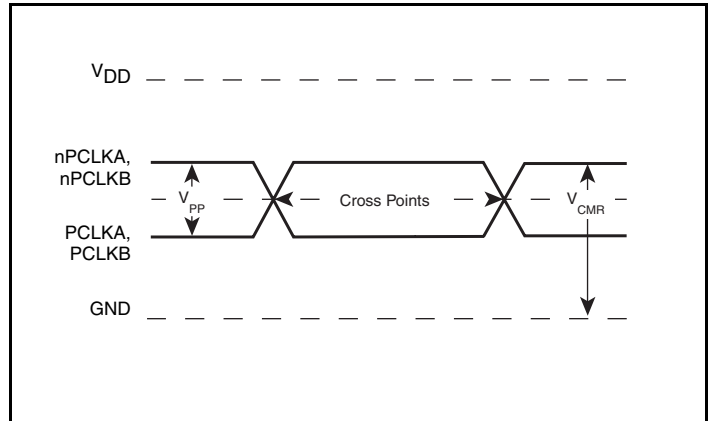

Differential Input Level

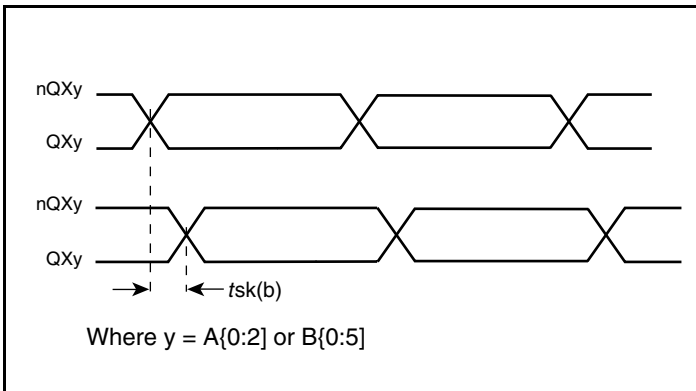

Bank Skew

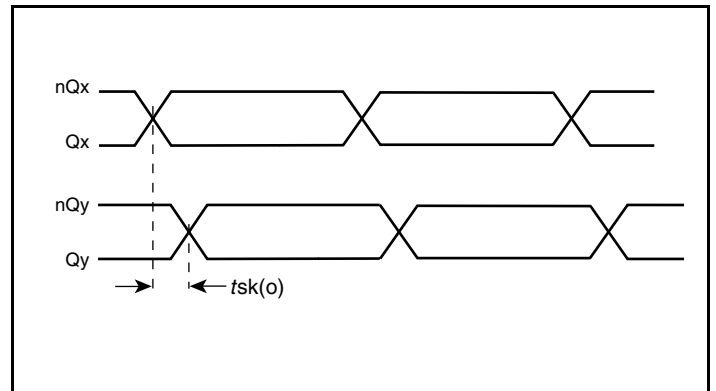

Output Skew

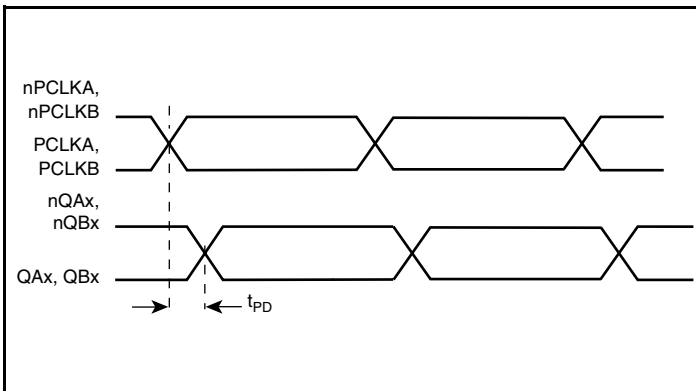

Propagation Delay

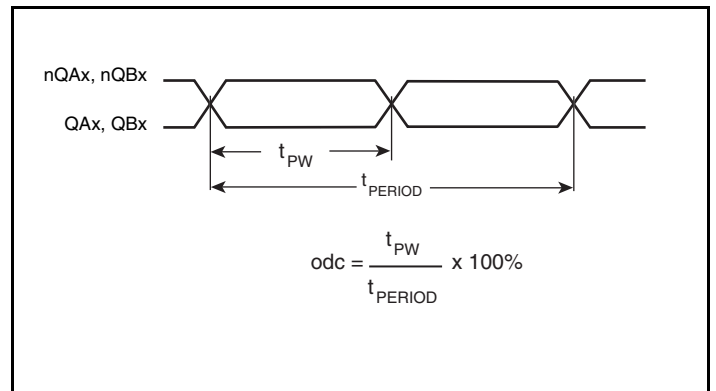

Output Duty Cycle/Pulse Width/Period

Parameter Measurement Information, continued

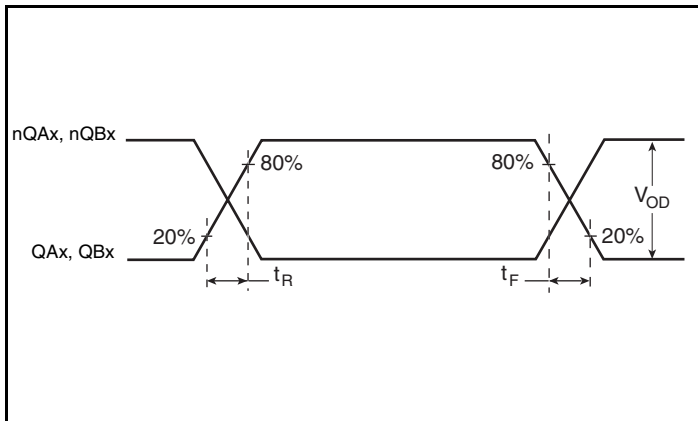

Output Rise/Fall Time

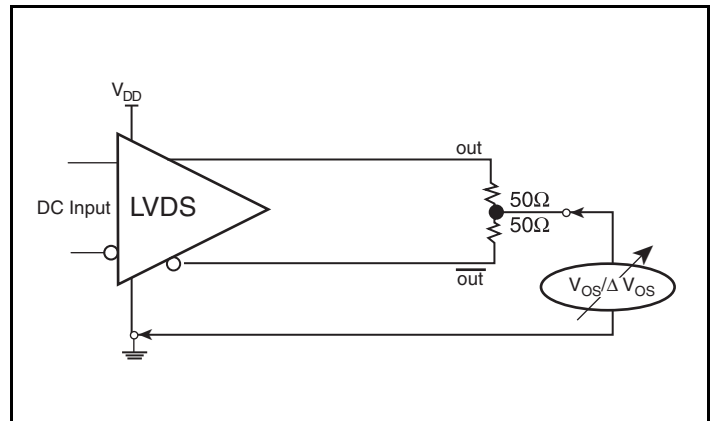

Offset Voltage Setup

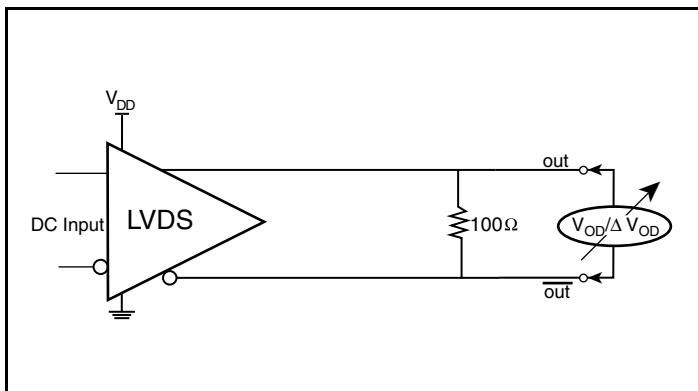

Differential Output Voltage Setup

Application Information

Recommendations for Unused Input and Output Pins

Inputs:

PCLK/nPCLK Inputs

For applications not requiring the use of a differential input, both the PCLK and nPCLK pins can be left floating. Though not required, but for additional protection, a 1k Ω resistor can be tied from PCLK to ground.

Outputs:

LVDS Outputs

All unused LVDS output pairs can be either left floating or terminated with 100 Ω across. If they are left floating, there should be no trace attached.

Wiring the Differential Input to Accept Single-Ended Levels

Figure 1 shows how the differential input can be wired to accept single-ended levels. The reference voltage $V_{REF} = V_{DD}/2$ is generated by the bias resistors R1, R2 and C1. This bias circuit should be located as close as possible to the input pin. The ratio of R1 and R2 might need to be adjusted to position the V_{REF} in the center of the input voltage swing. For example, if the input clock swing is only 2.5V and $V_{DD} = 3.3V$, V_{REF} should be 1.25V and $R2/R1 = 0.609$.

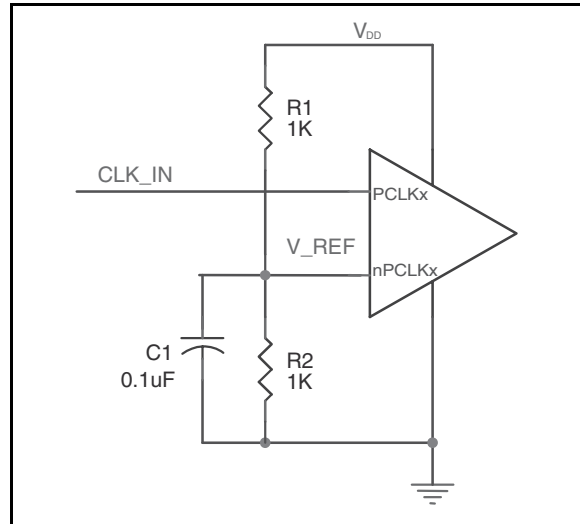

Figure 1. Single-Ended Signal Driving Differential Input

LVPECL Clock Input Interface

The PCLK /nPCLK accepts LVPECL, CML, SSTL and other differential signals. The differential signal must meet the V_{PP} and V_{CMR} input requirements. Figures 2A to 2F show interface examples for the PCLK/ nPCLK input driven by the most common driver types.

The input interfaces suggested here are examples only. If the driver is from another vendor, use their termination recommendation. Please consult with the vendor of the driver component to confirm the driver termination requirements.

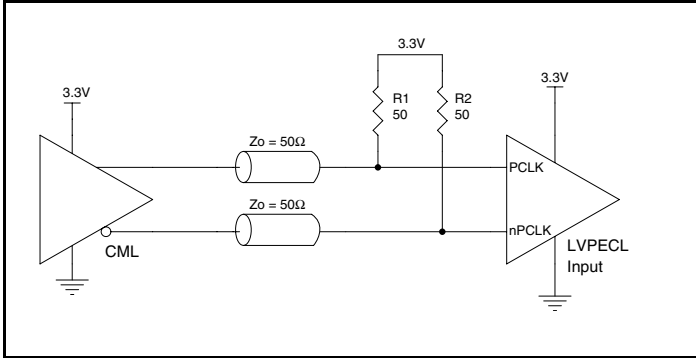

Figure 2A. PCLK/nPCLK Input Driven by a CML Driver

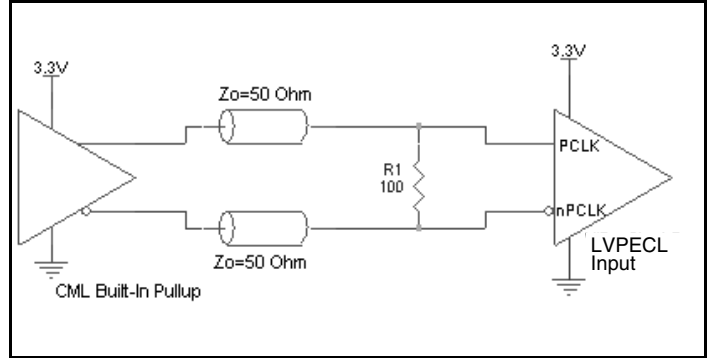

Figure 2B. PCLK/nPCLK Input Driven by a Built-In Pullup CML Driver

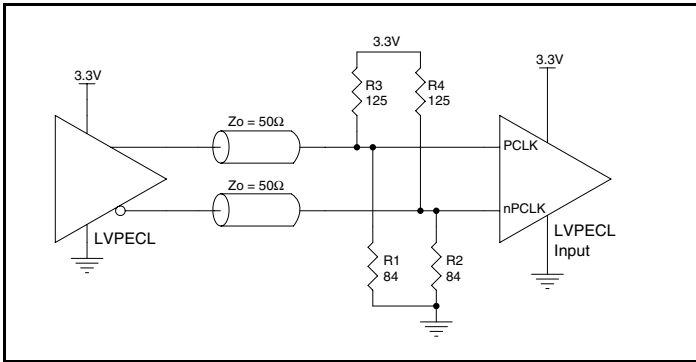

Figure 2C. PCLK/nPCLK Input Driven by a 3.3V LVPECL Driver

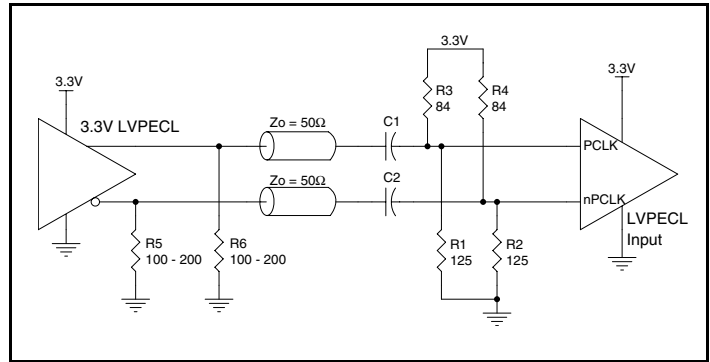

Figure 2D. PCLK/nPCLK Input Driven by a 3.3V LVPECL Driver with AC Couple

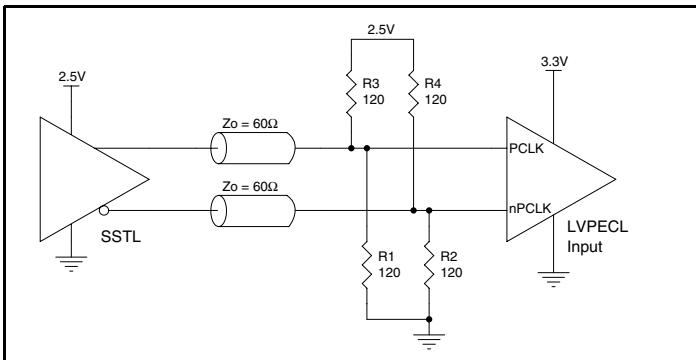

Figure 2E. PCLK/nPCLK Input Driven by an SSTL Driver

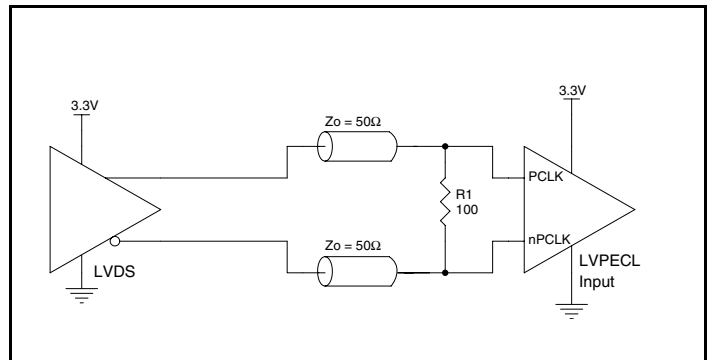

Figure 2F. PCLK/nPCLK Input Driven by a 3.3V LVDS Driver

3.3V LVDS Driver Termination

A general LVDS interface is shown in *Figure 3*. In a 100Ω differential transmission line environment, LVDS drivers require a matched load termination of 100Ω across near the receiver input. For a multiple

LVDS outputs buffer, if only partial outputs are used, it is recommended to terminate the unused outputs.

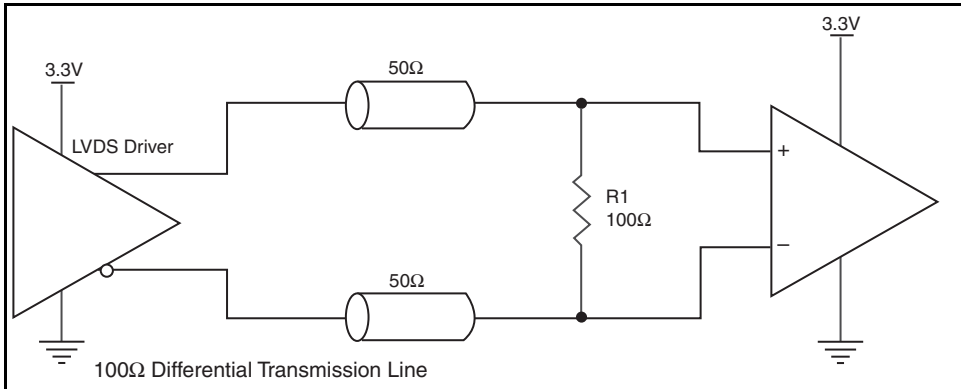

Figure 3. Typical LVDS Driver Termination

VFQFN EPAD Thermal Release Path

In order to maximize both the removal of heat from the package and the electrical performance, a land pattern must be incorporated on the Printed Circuit Board (PCB) within the footprint of the package corresponding to the exposed metal pad or exposed heat slug on the package, as shown in *Figure 4*. The solderable area on the PCB, as defined by the solder mask, should be at least the same size/shape as the exposed pad/slug area on the package to maximize the thermal/electrical performance. Sufficient clearance should be designed on the PCB between the outer edges of the land pattern and the inner edges of pad pattern for the leads to avoid any shorts.

While the land pattern on the PCB provides a means of heat transfer and electrical grounding from the package to the board through a solder joint, thermal vias are necessary to effectively conduct from the surface of the PCB to the ground plane(s). The land pattern must be connected to ground through these vias. The vias act as “heat pipes”. The number of vias (i.e. “heat pipes”) are application specific

and dependent upon the package power dissipation as well as electrical conductivity requirements. Thus, thermal and electrical analysis and/or testing are recommended to determine the minimum number needed. Maximum thermal and electrical performance is achieved when an array of vias is incorporated in the land pattern. It is recommended to use as many vias connected to ground as possible. It is also recommended that the via diameter should be 12 to 13mils (0.30 to 0.33mm) with 1oz copper via barrel plating. This is desirable to avoid any solder wicking inside the via during the soldering process which may result in voids in solder between the exposed pad/slug and the thermal land. Precautions should be taken to eliminate any solder voids between the exposed heat slug and the land pattern. Note: These recommendations are to be used as a guideline only. For further information, please refer to the Application Note on the Surface Mount Assembly of Amkor’s Thermally/Electrically Enhance Leadframe Base Package, Amkor Technology.

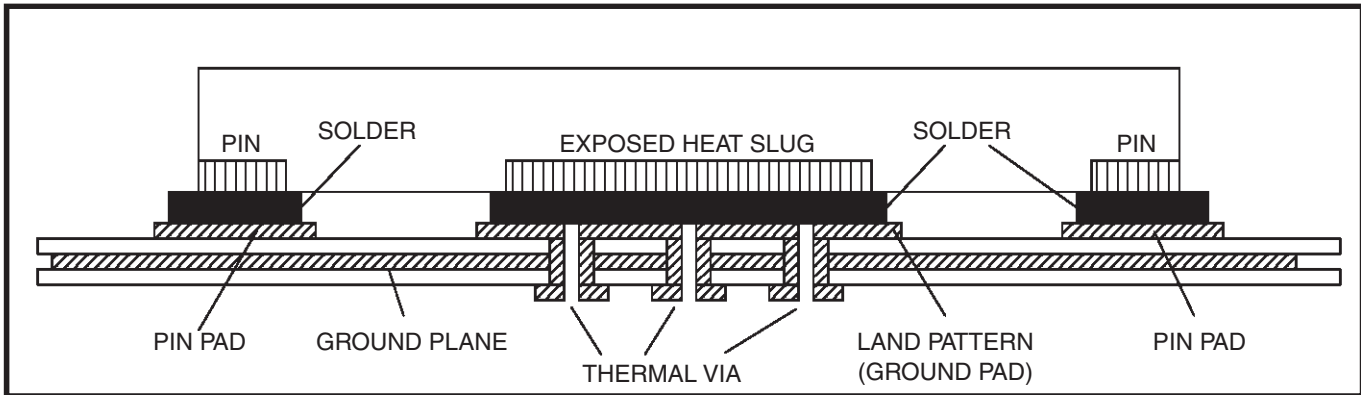

Figure 4. P.C. Assembly for Exposed Pad Thermal Release Path – Side View (drawing not to scale)

Power Considerations

This section provides information on power dissipation and junction temperature for the ICS854S036. Equations and example calculations are also provided.

1. Power Dissipation.

The total power dissipation for the ICS854S036 is the sum of the core power plus the power dissipated in the load(s). The following is the power dissipation for $V_{DD} = 3.3V + 5\% = 3.465V$, which gives worst case results.

NOTE: Please refer to Section 3 for details on calculating power dissipated in the load.

- Power (core)_{MAX} = $V_{DD_MAX} * I_{DD_MAX} = 3.465V * 210mA = 727.65mW$

2. Junction Temperature.

Junction temperature, T_j , is the temperature at the junction of the bond wire and bond pad directly affects the reliability of the device. The maximum recommended junction temperature for HiPerClockS devices is 125°C. Limiting the internal transistor junction temperature, T_j , to 125°C ensures that the bond wire and bond pad temperature remains below 125°C.

The equation for T_j is as follows: $T_j = \theta_{JA} * Pd_total + T_A$

T_j = Junction Temperature

θ_{JA} = Junction-to-Ambient Thermal Resistance

Pd_total = Total Device Power Dissipation (example calculation is in section 1 above)

T_A = Ambient Temperature

In order to calculate junction temperature, the appropriate junction-to-ambient thermal resistance θ_{JA} must be used. Assuming no air flow and a multi-layer board, the appropriate value is 42.7°C/W per Table 6 below.

Therefore, T_j for an ambient temperature of 70°C with all outputs switching is:

$$70^\circ\text{C} + 0.728\text{W} * 42.7^\circ\text{C/W} = 101.1^\circ\text{C}. \text{ This is below the limit of } 125^\circ\text{C}.$$

This calculation is only an example. T_j will obviously vary depending on the number of loaded outputs, supply voltage, air flow and the type of board (multi-layer).

Table 6. Thermal Resistance θ_{JA} for 32 Lead VFQFN, Forced Convection

| Meters per Second | θ_{JA} by Velocity | | |
|---------------------------------------------|---------------------------|----------|----------|
| | 0 | 1 | 2.5 |
| Multi-Layer PCB, JEDEC Standard Test Boards | 42.7°C/W | 37.3°C/W | 33.5°C/W |

Reliability Information

Table 7. θ_{JA} vs. Air Flow Table for a 32 Lead VFQFN

| θ_{JA} by Velocity | | | |
|---------------------------------------------|----------|----------|----------|
| Meters per Second | 0 | 1 | 2.5 |
| Multi-Layer PCB, JEDEC Standard Test Boards | 42.7°C/W | 37.3°C/W | 33.5°C/W |

Transistor Count

The transistor count for ICS854S036 is: 504

Package Outline and Package Dimensions

Package Outline - K Suffix for 32 Lead VFQFN

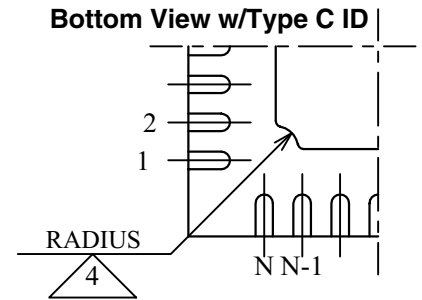
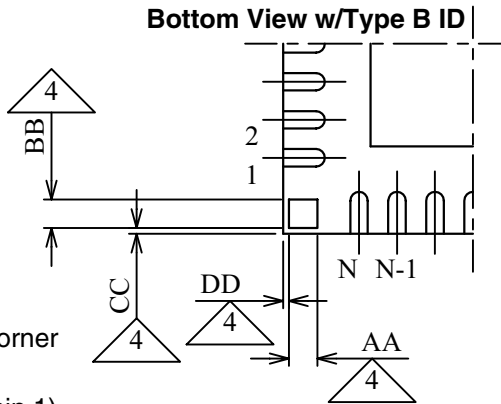
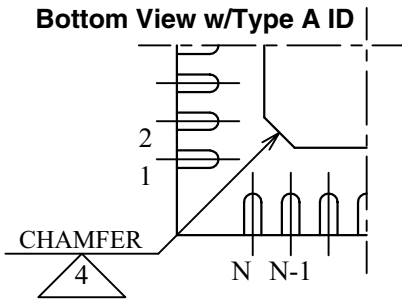
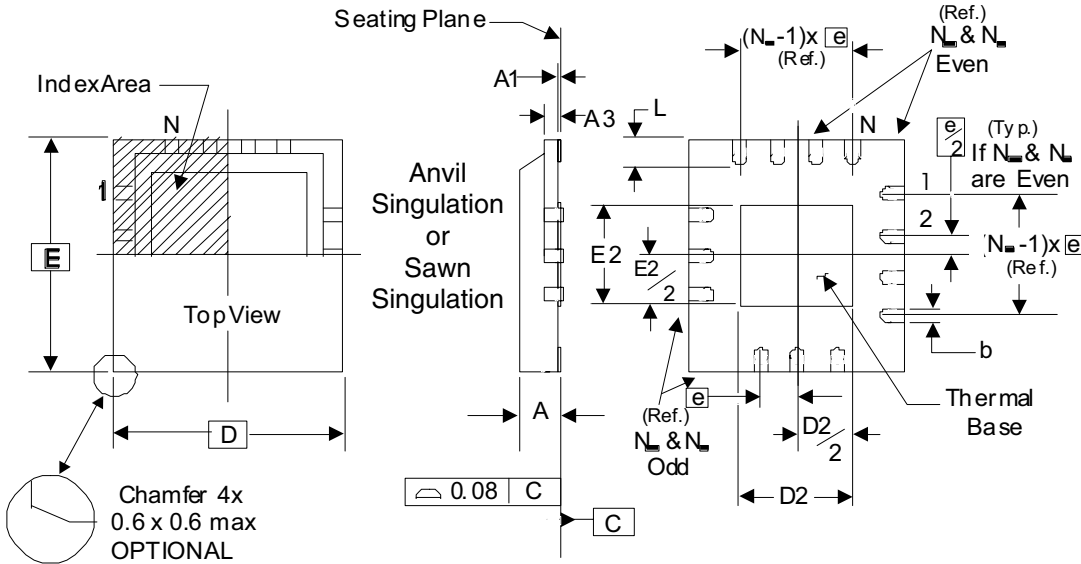

There are 3 methods of indicating pin 1 corner at the back of the VFQFN package are:

1. Type A: Chamfer on the paddle (near pin 1)
2. Type B: Dummy pad between pin 1 and N.
3. Type C: Mouse bite on the paddle (near pin 1)

Table 8. Package Dimensions

| JEDEC Variation: VHHD-2/-4 | | | |
|-------------------------------|------------|---------|---------|
| All Dimensions in Millimeters | | | |
| Symbol | Minimum | Nominal | Maximum |
| N | 32 | | |
| A | 0.80 | | 1.00 |
| A1 | 0 | | 0.05 |
| A3 | 0.25 Ref. | | |
| b | 0.18 | 0.25 | 0.30 |
| N_D & N_E | 8 | | |
| D & E | 5.00 Basic | | |
| D2 & E2 | 3.0 | | 3.3 |
| e | 0.50 Basic | | |
| L | 0.30 | 0.40 | 0.50 |

NOTE: The following package mechanical drawing is a generic drawing that applies to any pin count VFQFN package. This drawing is not intended to convey the actual pin count or pin layout of this device. The pin count and pinout are shown on the front page. The package dimensions are in Table 8.

Reference Document: JEDEC Publication 95, MO-220

Ordering Information

Table 9. Ordering Information

| Part/Order Number | Marking | Package | Shipping Packaging | Temperature |
|-------------------|-------------|---------------------------|--------------------|-------------|
| 854S036AKLF | ICS54S036AL | "Lead-Free" 32 Lead VFQFN | Tray | 0°C to 70°C |
| 854S036AKLFT | ICS54S036AL | "Lead-Free" 32 Lead VFQFN | 2500 Tape & Reel | 0°C to 70°C |

NOTE: Parts that are ordered with an "LF" suffix to the part number are the Pb-Free configuration and are RoHS compliant.

While the information presented herein has been checked for both accuracy and reliability, Integrated Device Technology (IDT) assumes no responsibility for either its use or for the infringement of any patents or other rights of third parties, which would result from its use. No other circuits, patents, or licenses are implied. This product is intended for use in normal commercial applications. Any other applications, such as those requiring extended temperature ranges, high reliability or other extraordinary environmental requirements are not recommended without additional processing by IDT. IDT reserves the right to change any circuitry or specifications without notice. IDT does not authorize or warrant any IDT product for use in life support devices or critical medical instruments.



www.IDT.com

6024 Silver Creek Valley Road
San Jose, California 95138

Sales
800-345-7015 (inside USA)
+408-284-8200 (outside USA)
Fax: 408-284-2775
www.IDT.com/go/contactIDT

Technical Support
netcom@idt.com
+480-763-2056

DISCLAIMER Integrated Device Technology, Inc. (IDT) and its subsidiaries reserve the right to modify the products and/or specifications described herein at any time and at IDT's sole discretion. All information in this document, including descriptions of product features and performance, is subject to change without notice. Performance specifications and the operating parameters of the described products are determined in the independent state and are not guaranteed to perform the same way when installed in customer products. The information contained herein is provided without representation or warranty of any kind, whether express or implied, including, but not limited to, the suitability of IDT's products for any particular purpose, an implied warranty of merchantability, or non-infringement of the intellectual property rights of others. This document is presented only as a guide and does not convey any license under intellectual property rights of IDT or any third parties.

IDT's products are not intended for use in life support systems or similar devices where the failure or malfunction of an IDT product can be reasonably expected to significantly affect the health or safety of users. Anyone using an IDT product in such a manner does so at their own risk, absent an express, written agreement by IDT.

Integrated Device Technology, IDT and the IDT logo are registered trademarks of IDT. Other trademarks and service marks used herein, including protected names, logos and designs, are the property of IDT or their respective third party owners.

Copyright 2009. All rights reserved.