

General Description

The ICS854104I is a low skew, high performance 1-to-4 Differential-to-LVDS Clock Fanout Buffer. Utilizing Low Voltage Differential Signaling (LVDS), the ICS854104I provides a low power, low noise, solution for distributing clock signals over controlled impedances of 100Ω. The ICS854104I accepts a differential input level and translates it to LVDS output levels.

Guaranteed output and part-to-part skew characteristics make the ICS854104I ideal for those applications demanding well defined performance and repeatability.

Features

- Four differential LVDS output pairs
- One differential clock input pair
- CLK/nCLK can accept the following differential input levels: LVPECL, LVDS, LVHSTL, HCSSL, SSTL
- Each output has an individual OE control
- Maximum output frequency: 700MHz
- Translates differential input signals to LVDS levels
- Additive phase jitter, RMS: 0.232ps (typical)
- Output skew: 50ps (maximum)
- Part-to-part skew: 350ps (maximum)
- Propagation delay: 1.3ns (maximum)
- 3.3V operating supply
- -40°C to 85°C ambient operating temperature
- Available in (RoHS 6) package

Block Diagram

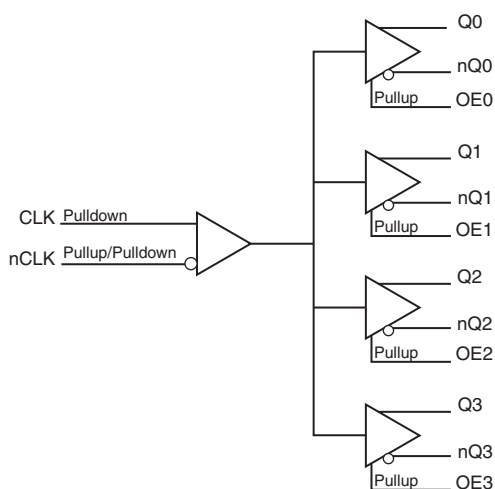

Pin Assignment

OE0	1	16	Q0
OE1	2	15	nQ0
OE2	3	14	Q1
V _{DD}	4	13	nQ1
GND	5	12	Q2
CLK	6	11	nQ2
nCLK	7	10	Q3
OE3	8	9	nQ3

ICS854104I

16-Lead TSSOP

4.4mm x 5.0mm x 0.925mm package body

G Package

Top View

Table 1. Pin Descriptions

Number	Name	Type		Description
1	OE0	Input	Pullup	Output enable pin for Q0, nQ0 outputs. See Table 3. LVCMOS/LVTTL interface levels.
2	OE1	Input	Pullup	Output enable pin for Q1, nQ1 outputs. See Table 3. LVCMOS/LVTTL interface levels.
3	OE2	Input	Pullup	Output enable pin for Q2, nQ2 outputs. See Table 3. LVCMOS/LVTTL interface levels.
4	V _{DD}	Power		Positive supply pin.
5	GND	Power		Power supply ground.
6	CLK	Input	Pulldown	Non-inverting differential clock input.
7	nCLK	Input	Pullup/Pulldown	Inverting differential clock input. V _{DD} /2 default when left floating.
8	OE3	Input	Pullup	Output enable pin for Q3, nQ3 outputs. See Table 3. LVCMOS/LVTTL interface levels.
9, 10	nQ3, Q3	Output		Differential output pair. LVDS interface levels.
11, 12	nQ2, Q2	Output		Differential output pair. LVDS interface levels.
13, 14	nQ1, Q1	Output		Differential output pair. LVDS interface levels.
15, 16	nQ0, Q0	Output		Differential output pair. LVDS interface levels.

NOTE: *Pullup* and *Pulldown* refer to internal input resistors. See Table 2, *Pin Characteristics*, for typical values.

Table 2. Pin Characteristics

Symbol	Parameter	Test Conditions	Minimum	Typical	Maximum	Units
C _{IN}	Input Capacitance			4		pF
R _{PULLUP}	Input Pullup Resistor			51		kΩ
R _{PULLDOWN}	Input Pulldown Resistor			51		kΩ

Function Table**Table 3. Output Enable Function Table**

Inputs	Outputs
OE[3:0]	Q[0:3], nQ[0:3]
0	High-Impedance
1	Active (default)

Absolute Maximum Ratings

NOTE: Stresses beyond those listed under *Absolute Maximum Ratings* may cause permanent damage to the device. These ratings are stress specifications only. Functional operation of product at these conditions or any conditions beyond those listed in the *DC Characteristics* or *AC Characteristics* is not implied. Exposure to absolute maximum rating conditions for extended periods may affect product reliability.

Item	Rating
Supply Voltage, V_{DD}	4.6V
Inputs, V_I	-0.5V to $V_{DD} + 0.5V$
Outputs, I_O (LVDS) Continuous Current Surge Current	10mA 15mA
Package Thermal Impedance, θ_{JA}	100.3°C/W (0 mps)
Storage Temperature, T_{STG}	-65°C to 150°C

DC Electrical Characteristics

Table 4A. LVDS Power Supply DC Characteristics, $V_{DD} = 3.3V \pm 5\%$, $T_A = -40^\circ C$ to $85^\circ C$

Symbol	Parameter	Test Conditions	Minimum	Typical	Maximum	Units
V_{DD}	Positive Supply Voltage		3.135	3.3	3.465	V
I_{DD}	Power Supply Current				75	mA

Table 4B. LVCMOS/LVTTL DC Characteristics, $V_{DD} = 3.3V \pm 5\%$, $T_A = -40^\circ C$ to $85^\circ C$

Symbol	Parameter	Test Conditions	Minimum	Typical	Maximum	Units
V_{IH}	Input High Voltage		2		$V_{DD} + 0.3$	V
V_{IL}	Input Low Voltage		-0.3		0.8	V
I_{IH}	Input High Current	$V_{DD} = V_{IN} = 3.465V$			150	μA
I_{IL}	Input Low Current	$V_{DD} = 3.465V, V_{IN} = 0V$	-5			μA

Table 4C. Differential DC Characteristics, $V_{DD} = 3.3V \pm 5\%$, $T_A = -40^\circ C$ to $85^\circ C$

Symbol	Parameter	Test Conditions	Minimum	Typical	Maximum	Units
I_{IH}	Input High Current	CLK, nCLK $V_{DD} = V_{IN} = 3.465V$			150	μA
I_{IL}	Input Low Current	CLK $V_{DD} = 3.465V, V_{IN} = 0V$	-5			μA
		nCLK $V_{DD} = 3.465V, V_{IN} = 0V$	-150			μA
V_{PP}	Peak-to-Peak Voltage; NOTE 1		0.15		1.3	V
V_{CMR}	Common Mode Input Voltage; NOTE 1, 2		GND + 0.5		$V_{DD} - 0.85$	V

NOTE 1: V_{IL} should not be less than -0.3V.

NOTE 2: Common mode input voltage is defined as V_{IH} .

Table 4D. LVDS DC Characteristics, $V_{DD} = 3.3V \pm 5\%$, $T_A = -40^\circ\text{C}$ to 85°C

Symbol	Parameter	Test Conditions	Minimum	Typical	Maximum	Units
V_{OD}	Differential Output Voltage		250	350	450	mV
ΔV_{OD}	V_{OD} Magnitude Change				50	mV
V_{OS}	Offset Voltage		1.2	1.3	1.45	V
ΔV_{OS}	V_{OS} Magnitude Change				50	mV

Table 5. AC Characteristics, $V_{DD} = 3.3V \pm 5\%$, $T_A = -40^\circ\text{C}$ to 85°C

Symbol	Parameter	Test Conditions	Minimum	Typical	Maximum	Units
f_{MAX}	Output Frequency				700	MHz
t_{PD}	Propagation Delay; NOTE 1		0.9		1.3	ns
f_{jit}	Buffer Additive Phase Jitter, RMS; refer to Additive Phase Jitter Section	155.52MHz, Integration Range: 12kHz – 20MHz		0.232	0.245	ps
		100MHz, Integration Range: 12kHz – 20MHz		0.235	0.250	ps
$tsk(o)$	Output Skew; NOTE 2, 4				50	ps
$tsk(pp)$	Part-to-Part Skew; NOTE 3, 4				350	ps
t_R / t_F	Output Rise/Fall Time	20% to 80%	180		660	ps
odc	Output Duty Cycle		45		55	%

NOTE: Electrical parameters are guaranteed over the specified ambient operating temperature range, which is established when the device is mounted in a test socket with maintained transverse airflow greater than 500 lpm. The device will meet specifications after thermal equilibrium has been reached under these conditions.

NOTE: All parameters measured at f_{MAX} unless noted otherwise.

NOTE 1: Measured from the differential input crossing point to the differential output crossing point.

NOTE 2: Defined as skew between outputs at the same supply voltage and with equal load conditions. Measured at the differential crossing point of the input to the differential output crossing point.

NOTE 3: Defined as skew between outputs on different devices operating at the same supply voltages and with equal load conditions. Using the same type of inputs on each device, the outputs are measured at the differential cross points.

NOTE 4: This parameter is defined in accordance with JEDEC Standard 65.

Additive Phase Jitter

The spectral purity in a band at a specific offset from the fundamental compared to the power of the fundamental is called the ***dBc Phase Noise***. This value is normally expressed using a Phase noise plot and is most often the specified plot in many applications. Phase noise is defined as the ratio of the noise power present in a 1Hz band at a specified offset from the fundamental frequency to the power value of the fundamental. This ratio is expressed in decibels (dBm) or a ratio

of the power in the 1Hz band to the power in the fundamental. When the required offset is specified, the phase noise is called a ***dBc*** value, which simply means dBm at a specified offset from the fundamental. By investigating jitter in the frequency domain, we get a better understanding of its effects on the desired application over the entire time record of the signal. It is mathematically possible to calculate an expected bit error rate given a phase noise plot.

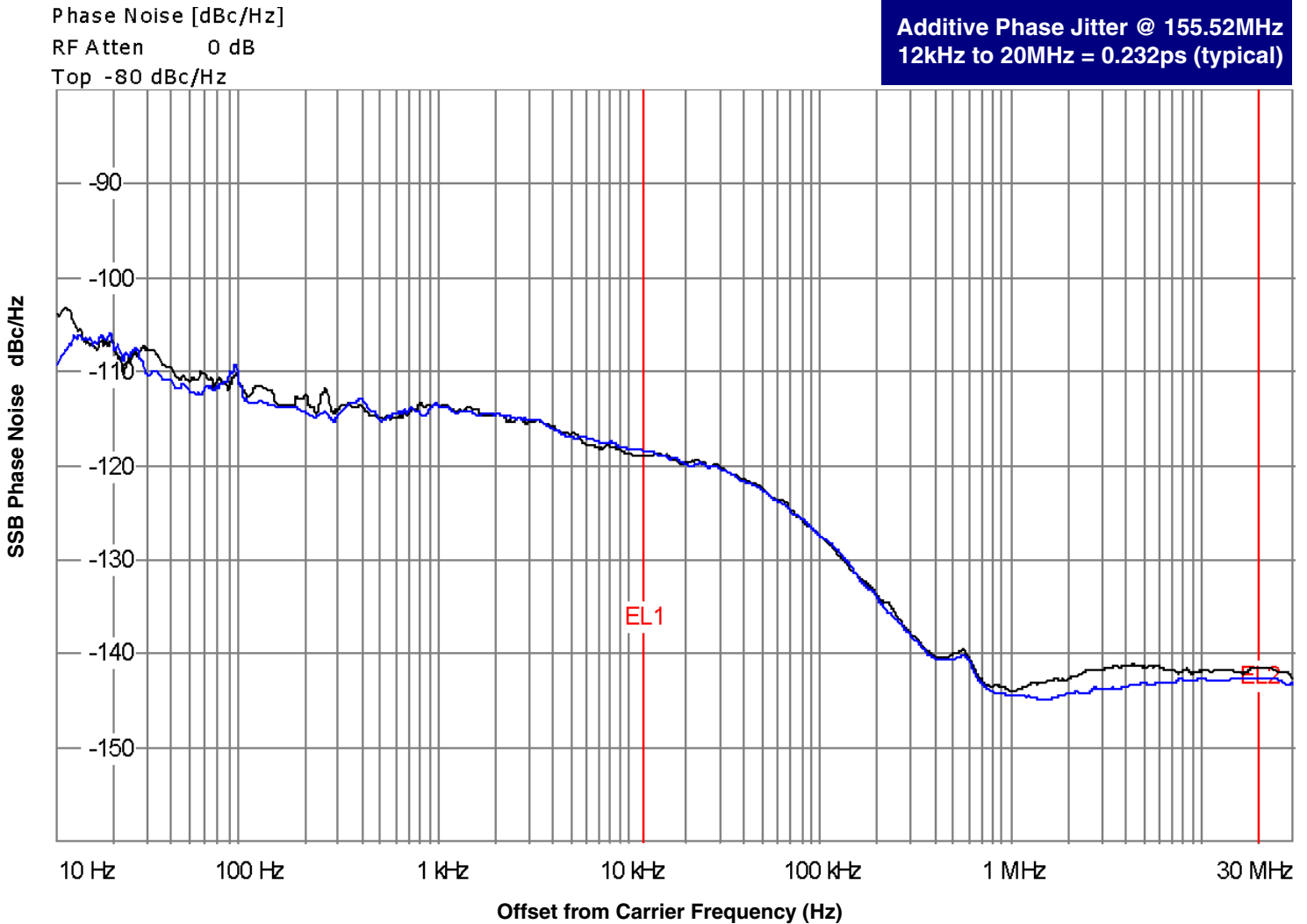

As with most timing specifications, phase noise measurements has issues relating to the limitations of the equipment. Often the noise floor of the equipment is higher than the noise floor of the device. This is illustrated above. The device meets the noise floor of what is shown, but can actually be lower. The phase noise is dependent on the input source and measurement equipment.

The source generator is the Rhode & Schwarz SMA 100A Signal Generator 9kHz – 6GHz. Phase noise is measured with the Agilent E5052A Signal source Analyzer.

Parameter Measurement Information

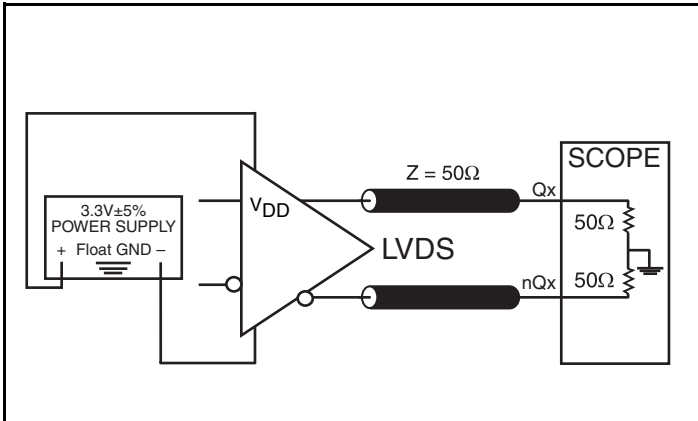

3.3V LVDS Output Load AC Test Circuit

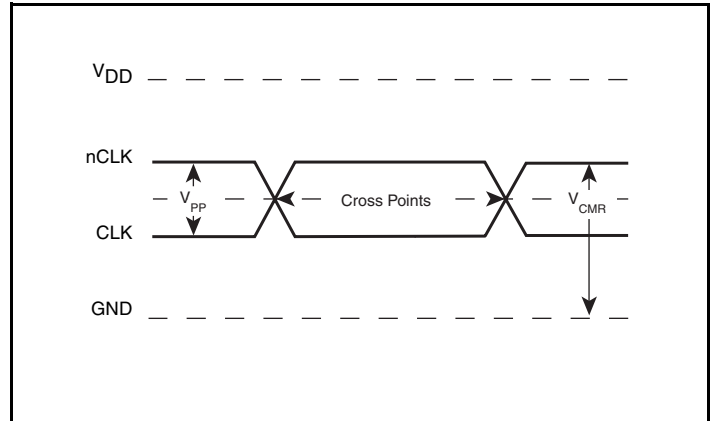

Differential Input Level

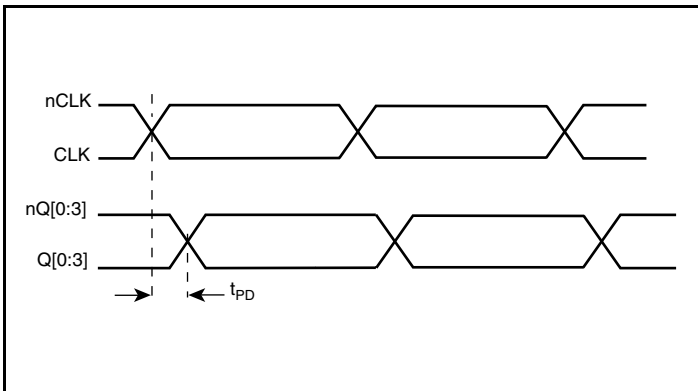

Propagation Delay

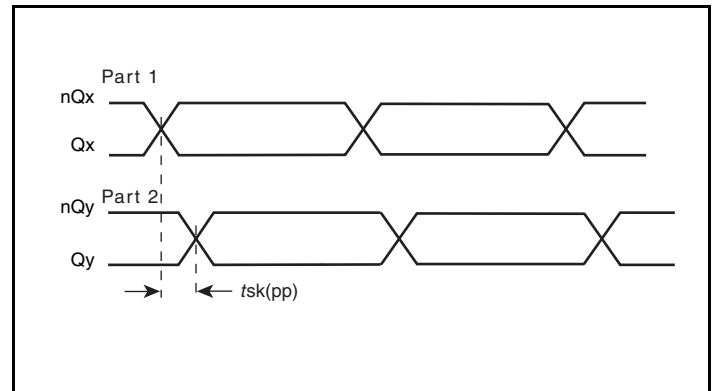

Part-to-Part Skew

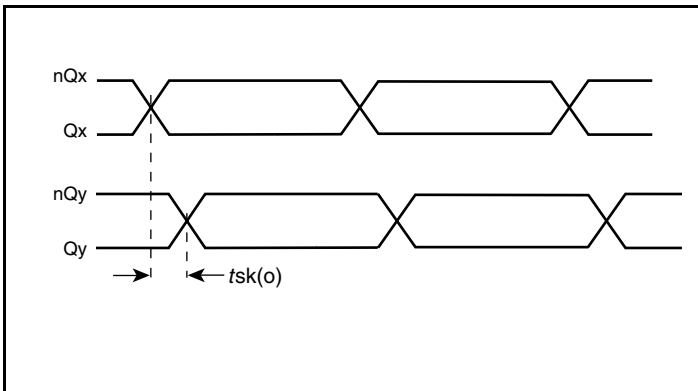

Output Skew

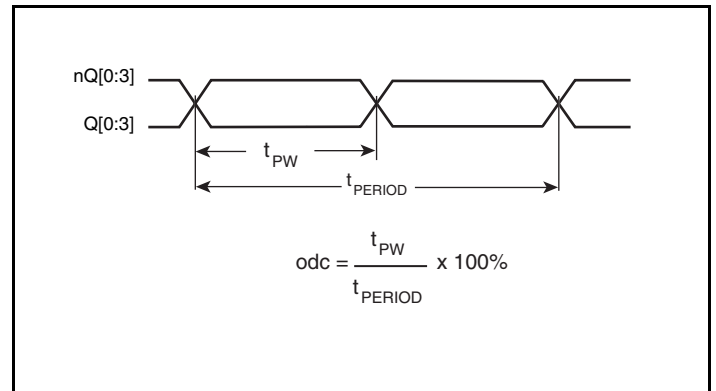

Output Duty Cycle/Pulse Width/Period

Parameter Measurement Information, continued

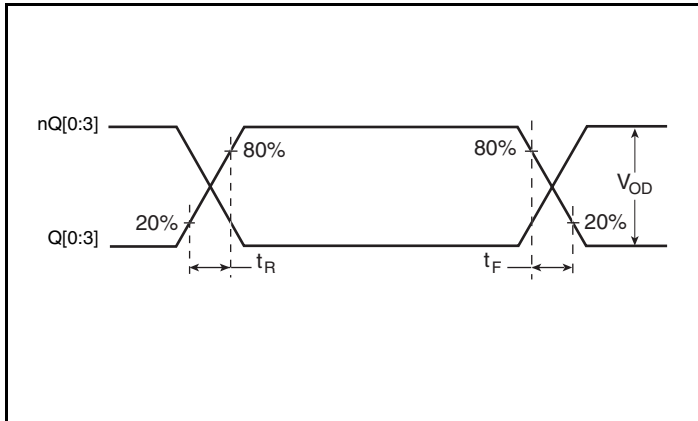

Output Rise/Fall Time

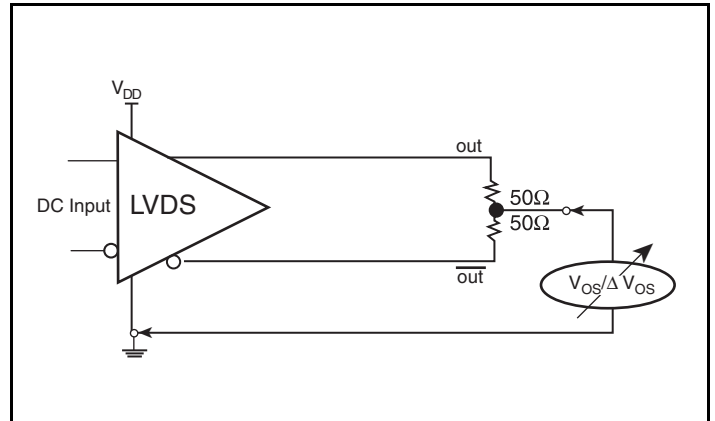

Offset Voltage Setup

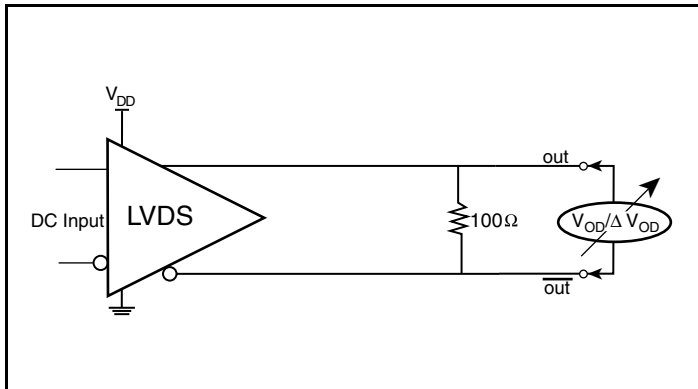

Differential Output Voltage Setup

Applications Information

Wiring the Differential Input to Accept Single-Ended Levels

Figure 1 shows how a differential input can be wired to accept single ended levels. The reference voltage $V_{REF} = V_{DD}/2$ is generated by the bias resistors R1 and R2. The bypass capacitor (C1) is used to help filter noise on the DC bias. This bias circuit should be located as close to the input pin as possible. The ratio of R1 and R2 might need to be adjusted to position the V_{REF} in the center of the input voltage swing. For example, if the input clock swing is 2.5V and $V_{DD} = 3.3V$, R1 and R2 value should be adjusted to set V_{REF} at 1.25V. The values below are for when both the single ended swing and V_{DD} are at the same voltage. This configuration requires that the sum of the output impedance of the driver (R_o) and the series resistance (R_s) equals the transmission line impedance. In addition, matched termination at the input will attenuate the signal in half. This can be done in one of two ways. First, R3 and R4 in parallel should equal the transmission

line impedance. For most 50Ω applications, R3 and R4 can be 100Ω. The values of the resistors can be increased to reduce the loading for slower and weaker LVCMOS driver. When using single-ended signaling, the noise rejection benefits of differential signaling are reduced. Even though the differential input can handle full rail LVCMOS signaling, it is recommended that the amplitude be reduced. The datasheet specifies a lower differential amplitude, however this only applies to differential signals. For single-ended applications, the swing can be larger, however V_{IL} cannot be less than -0.3V and V_{IH} cannot be more than $V_{DD} + 0.3V$. Though some of the recommended components might not be used, the pads should be placed in the layout. They can be utilized for debugging purposes. The datasheet specifications are characterized and guaranteed by using a differential signal.

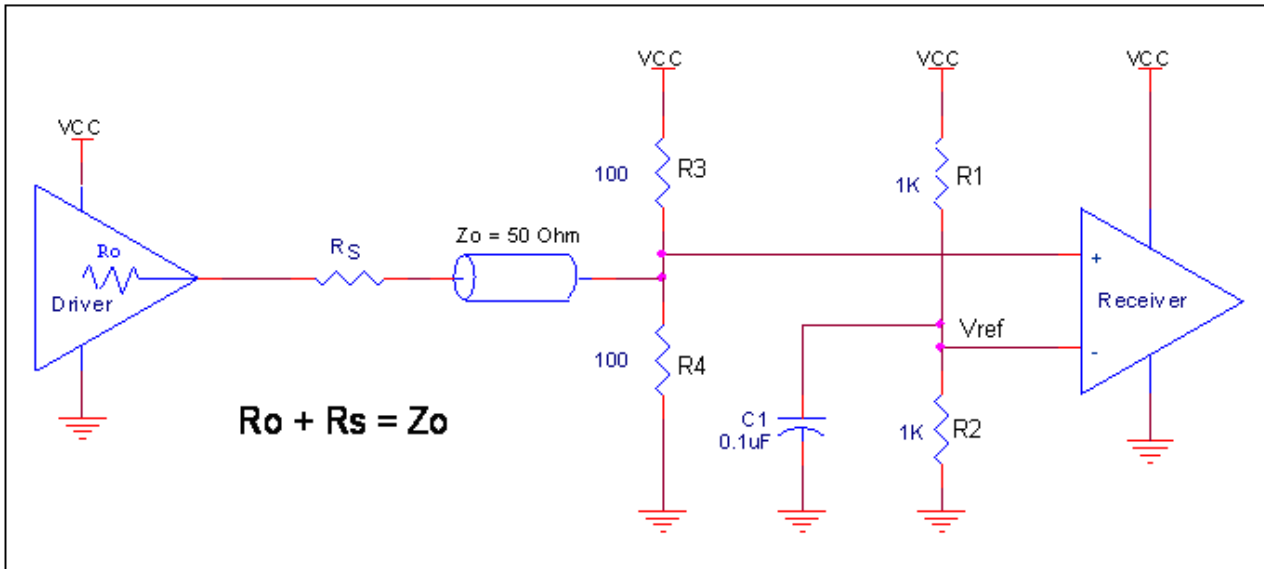

Figure 1. Recommended Schematic for Wiring a Differential Input to Accept Single-ended Levels

Recommendations for Unused Input and Output Pins

Inputs:

LVCMOS Control Pins

All control pins have internal pullups; additional resistance is not required but can be added for additional protection. A 1kΩ resistor can be used.

Outputs:

LVDS Outputs

All unused LVDS output pairs can be either left floating or terminated with 100Ω across. If they are left floating, there should be no trace attached.

Differential Clock Input Interface

The CLK /nCLK accepts LVDS, LVPECL, LVHSTL, SSTL, HCSL and other differential signals. Both signals must meet the V_{PP} and V_{CMR} input requirements. Figures 2A to 2F show interface examples for the CLK/nCLK input driven by the most common driver types. The input interfaces suggested here are examples only. Please consult with the

vendor of the driver component to confirm the driver termination requirements. For example, in Figure 2A, the input termination applies for IDT open emitter LVHSTL drivers. If you are using an LVHSTL driver from another vendor, use their termination recommendation.

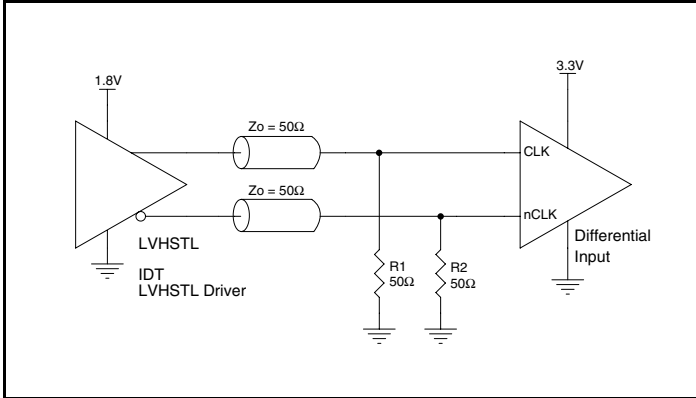

2A. CLK/nCLK Input Driven by an IDT Open Emitter LVHSTL Driver

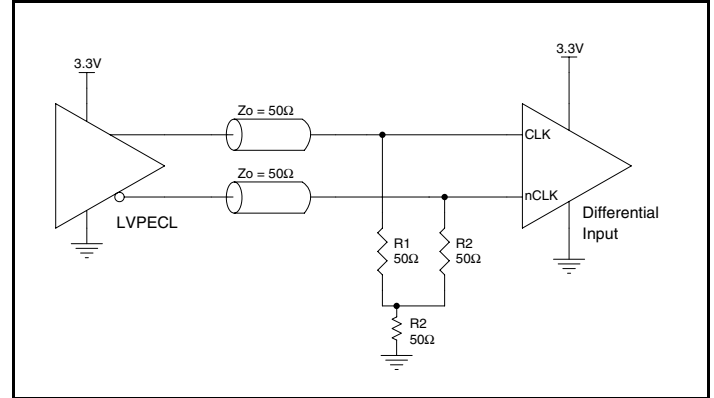

Figure 2B. CLK/nCLK Input Driven by a 3.3V LVPECL Driver

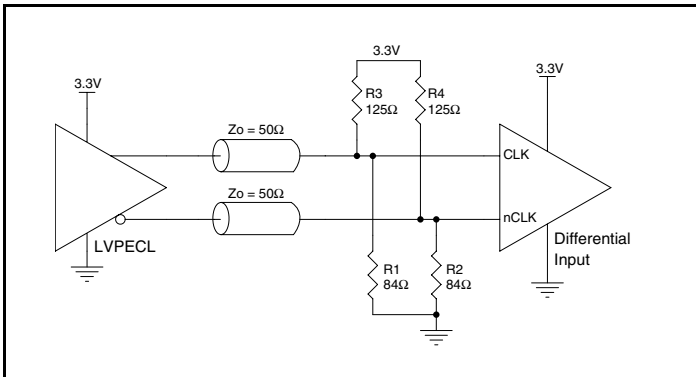

Figure 2C. CLK/nCLK Input Driven by a 3.3V LVPECL Driver

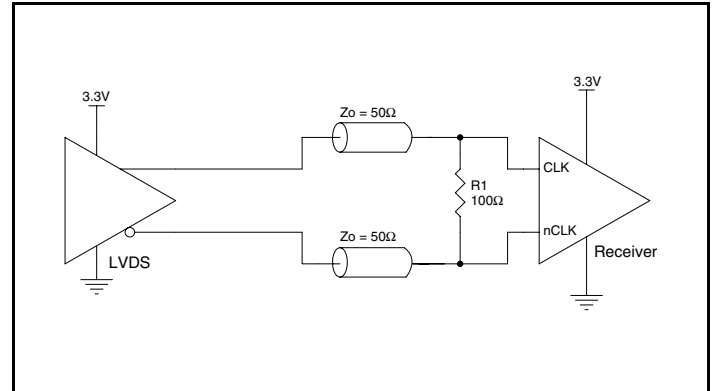

Figure 2D. CLK/nCLK Input Driven by a 3.3V LVDS Driver

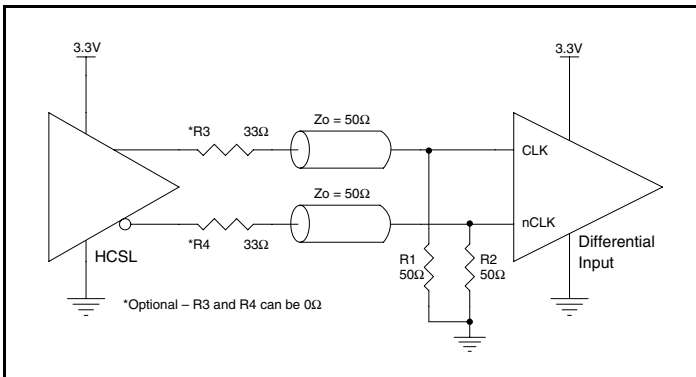

Figure 2E. CLK/nCLK Input Driven by a 3.3V HCSL Driver

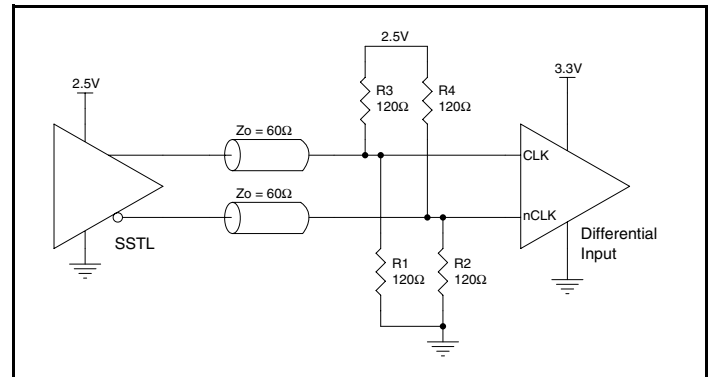

Figure 2F. CLK/nCLK Input Driven by a 2.5V SSTL Driver

LVDS Driver Termination

A general LVDS interface is shown in *Figure 3*. Standard termination for LVDS type output structure requires both a 100Ω parallel resistor at the receiver and a 100Ω differential transmission line environment. In order to avoid any transmission line reflection issues, the 100Ω resistor must be placed as close to the receiver as possible. IDT offers a full line of LVDS compliant devices with two types of output structures: current source and voltage source. The standard

termination schematic as shown in *Figure 3* can be used with either type of output structure. If using a non-standard termination, it is recommended to contact IDT and confirm if the output is a current source or a voltage source type structure. In addition, since these outputs are LVDS compatible, the amplitude and common mode input range of the input receivers should be verified for compatibility with the output.

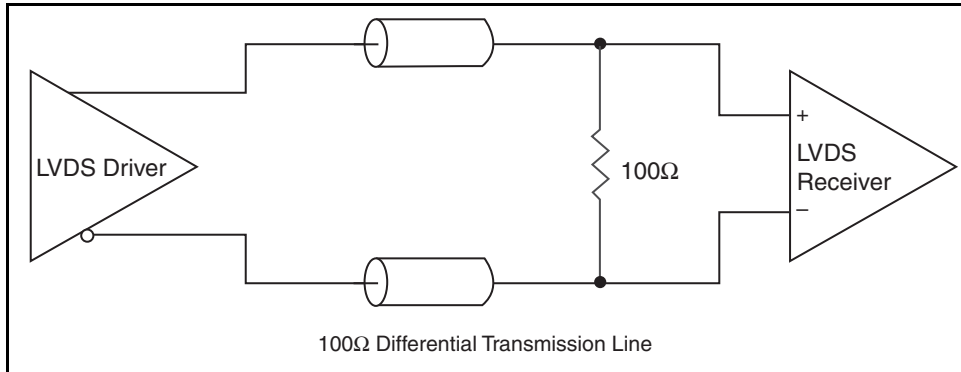

Figure 3. Typical LVDS Driver Termination

Power Considerations

This section provides information on power dissipation and junction temperature for the ICS854104I. Equations and example calculations are also provided.

1. Power Dissipation.

The total power dissipation for the ICS854104I is the sum of the core power plus the analog power plus the power dissipated in the load(s). The following is the power dissipation for $V_{DD} = 3.3V + 5\% = 3.465V$, which gives worst case results.

- Power (core)_{MAX} = $V_{DD_MAX} * I_{DD_MAX} = 3.465V * 75mA = 259.875mW$

2. Junction Temperature.

Junction temperature, T_j , is the temperature at the junction of the bond wire and bond pad directly affects the reliability of the device. The maximum recommended junction temperature is 125°C. Limiting the internal transistor junction temperature, T_j , to 125°C ensures that the bond wire and bond pad temperature remains below 125°C.

The equation for T_j is as follows: $T_j = \theta_{JA} * Pd_total + T_A$

T_j = Junction Temperature

θ_{JA} = Junction-to-Ambient Thermal Resistance

Pd_total = Total Device Power Dissipation (example calculation is in section 1 above)

T_A = Ambient Temperature

In order to calculate junction temperature, the appropriate junction-to-ambient thermal resistance θ_{JA} must be used. Assuming no air flow and a multi-layer board, the appropriate value is 100.3°C/W per Table 6 below.

Therefore, T_j for an ambient temperature of 85°C with all outputs switching is:

$$85^\circ C + 0.260W * 100.3^\circ C/W = 111.1^\circ C. \text{ This is well below the limit of } 125^\circ C.$$

This calculation is only an example. T_j will obviously vary depending on the number of loaded outputs, supply voltage, air flow and the type of board (multi-layer).

Table 6. Thermal Resistance θ_{JA} for 16 Lead TSSOP, Forced Convection

θ_{JA} by Velocity			
Meters per Second	0	1	2.5
Multi-Layer PCB, JEDEC Standard Test Boards	100.3°C/W	96.0°C/W	93.9°C/W

Reliability Information

Table 7. θ_{JA} vs. Air Flow Table for a 16 Lead TSSOP

θ_{JA} by Velocity			
Meters per Second	0	1	2.5
Multi-Layer PCB, JEDEC Standard Test Boards	100.3°C/W	96.0°C/W	93.9°C/W

Transistor Count

The transistor count for ICS854104I is: 286

Package Outline and Package Dimensions

Package Outline - G Suffix for 16 Lead TSSOP

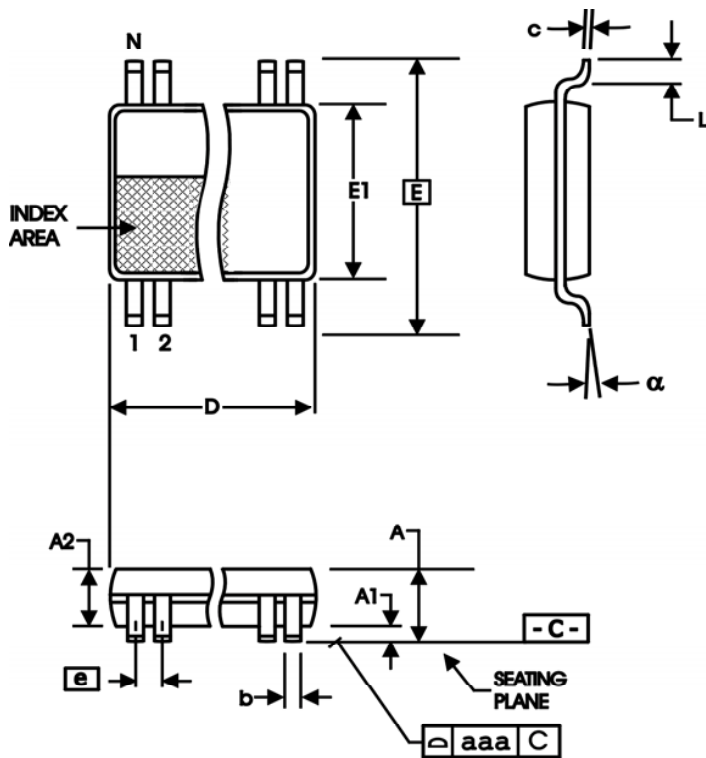

Table 8. Package Dimensions

All Dimensions in Millimeters		
Symbol	Minimum	Maximum
N	16	
A		1.20
A1	0.05	0.15
A2	0.80	1.05
b	0.19	0.30
c	0.09	0.20
D	4.90	5.10
E	6.40 Basic	
E1	4.30	4.50
e	0.65 Basic	
L	0.45	0.75
α	0°	8°
aaa	0.10	

Reference Document: JEDEC Publication 95, MO-153

Ordering Information

Table 9. Ordering Information

Part/Order Number	Marking	Package	Shipping Packaging	Temperature
854104AGILF	54104AIL	"Lead-Free" 16 Lead TSSOP	Tube	-40°C to 85°C
854104AGILFT	54104AIL	"Lead-Free" 16 Lead TSSOP	2500 Tape & Reel	-40°C to 85°C

NOTE: Parts that are ordered with an "LF" suffix to the part number are the Pb-Free configuration and are RoHS compliant.

While the information presented herein has been checked for both accuracy and reliability, Integrated Device Technology (IDT) assumes no responsibility for either its use or for the infringement of any patents or other rights of third parties, which would result from its use. No other circuits, patents, or licenses are implied. This product is intended for use in normal commercial and industrial applications. Any other applications, such as those requiring high reliability or other extraordinary environmental requirements are not recommended without additional processing by IDT. IDT reserves the right to change any circuitry or specifications without notice. IDT does not authorize or warrant any IDT product for use in life support devices or critical medical instruments.

Revision History Sheet

Rev	Table	Page	Description of Change	Date
A	T5	4	AC Characteristics - deleted "Bank A" test conditions from part-to-part skew row.	8/13/09
B	T5	4	AC Characteristics - Additive Phase Jitter, added maximum spec for 155.52MHz and added 100MHz specs.	9/10/10
		8	Updated <i>Wiring the Differential Input to Accept Single-ended Levels</i> .	
		10	Updated <i>LVDS Driver Termination</i> .	

We've Got Your Timing Solution



6024 Silver Creek Valley Road
San Jose, California 95138

Sales
800-345-7015 (inside USA)
+408-284-8200 (outside USA)
Fax: 408-284-2775
www.IDT.com/go/contactIDT

Technical Support
netcom@idt.com
+480-763-2056

DISCLAIMER Integrated Device Technology, Inc. (IDT) and its subsidiaries reserve the right to modify the products and/or specifications described herein at any time and at IDT's sole discretion. All information in this document, including descriptions of product features and performance, is subject to change without notice. Performance specifications and the operating parameters of the described products are determined in the independent state and are not guaranteed to perform the same way when installed in customer products. The information contained herein is provided without representation or warranty of any kind, whether express or implied, including, but not limited to, the suitability of IDT's products for any particular purpose, an implied warranty of merchantability, or non-infringement of the intellectual property rights of others. This document is presented only as a guide and does not convey any license under intellectual property rights of IDT or any third parties.

IDT's products are not intended for use in life support systems or similar devices where the failure or malfunction of an IDT product can be reasonably expected to significantly affect the health or safety of users. Anyone using an IDT product in such a manner does so at their own risk, absent an express, written agreement by IDT.

Integrated Device Technology, IDT and the IDT logo are registered trademarks of IDT. Other trademarks and service marks used herein, including protected names, logos and designs, are the property of IDT or their respective third party owners.

Copyright 2010. All rights reserved.