



# LOW SKEW, 1-TO-6, CRYSTAL OSCILLATOR/LVCMOS-TO-3.3V, 2.5V LVPECL/LVCMOS FANOUT BUFFER

**ICS8536I-33**

## GENERAL DESCRIPTION



The ICS8536I-33 is a low skew, high performance 1-to-6 Crystal Oscillator/LVCMOS-to-3.3V, 2.5V LVPECL/LVCMOS fanout buffer and a member of the HiPerClockS™ family of High Performance Clock Solutions from IDT. The ICS8536I-33 has selectable single ended clock or crystal inputs. The single-ended clock input accepts LVCMOS or LVTTTL input levels and translate them to 3.3V LVPECL levels. The output enable is internally synchronized to eliminate runt pulses on the outputs during asynchronous assertion/deassertion of the clock enable pin.

Guaranteed output and part-to-part skew characteristics make the ICS8536I-33 ideal for those applications demanding well defined performance and repeatability.

## FEATURES

- Three differential LVPECL outputs, and three single ended LVCMOS outputs
- Selectable LVCMOS/LVTTTL CLK or crystal inputs
- CLK can accept the following input levels: LVCMOS, LVTTTL
- Crystal frequency: 25MHz
- Maximum output frequency: 266MHz
- Output skew: 80ps (maximum)
- Part-to-part skew: 800ps (maximum)
- Propagation delay: 1.95ns (maximum)
- Additive phase jitter, RMS: 0.32ps (typical), LVPECL output
- Full 3.3V or 2.5V operating supply
- -40°C to 85°C ambient operating temperature
- Available in both standard (RoHS 5) and lead-free (RoHS 6) packages

## BLOCK DIAGRAM

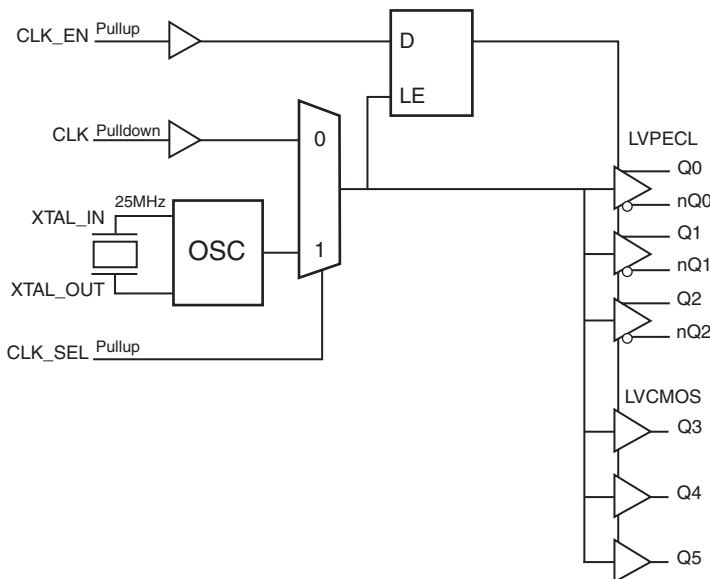

## PIN ASSIGNMENT

CLK_EN	1	20	VEE
XTAL_IN	2	19	Q5
XTAL_OUT	3	18	Q4
Vcc	4	17	VCCO_LVCMOS
CLK	5	16	Q3
CLK_SEL	6	15	VEE
VEE	7	14	Q2
Q0	8	13	nQ2
nQ0	9	12	nQ1
VCCO_LVPECL	10	11	Q1

### ICS8536I-33 20-Lead TSSOP

6.5mm x 4.4mm x 0.925mm package body  
**G Package**  
Top View

**TABLE 1. PIN DESCRIPTIONS**

Number	Name	Type		Description
1	CLK_EN	Input	Pullup	Synchronizing clock enable. When HIGH, clock outputs follows clock input. When LOW, Q outputs are forced low, nQ0 output is forced high. LVCMOS / LVTTTL interface levels.
2, 3	XTAL_IN, XTAL_OUT	Input		Crystal oscillator interface. XTAL_IN is the input. XTAL_OUT is the output.
4	V <sub>CC</sub>	Power		Positive supply pins.
5	CLK	Input	Pulldown	Single-ended clock input. LVCMOS / LVTTTL interface levels.
6	CLK_SEL	Input	Pullup	Clock select input. When HIGH, selects XTAL inputs. When LOW, selects CLK input. LVCMOS / LVTTTL interface levels.
7, 15, 20	V <sub>EE</sub>	Power		Negative supply pin.
8, 9	Q0, nQ0	Output		Differential clock outputs. LVPECL interface levels.
10	V <sub>CCO_LVPECL</sub>	Power		Output power supply mode for LVPECL clock outputs.
11, 12	Q1, nQ1	Output		Differential clock outputs. LVPECL interface levels.
13, 14	nQ2, Q2	Output		Differential clock outputs. LVPECL interface levels.
16, 18, 19	Q3, Q4, Q5	Output		Single ended clock outputs. LVCMOS / LVTTTL interface levels.
17	V <sub>CCO_LVCMOS</sub>	Power		Output power supply mode for LVCMOS / LVTTTL clock outputs.

NOTE: *Pullup* and *Pulldown* refer to internal input resistors. See Table 2, Pin Characteristics, for typical values.

**TABLE 2. PIN CHARACTERISTICS**

Symbol	Parameter	Test Conditions	Minimum	Typical	Maximum	Units
C <sub>IN</sub>	Input Capacitance			4		pF
C <sub>PD</sub>	Power Dissipation Capacitance (per output)	Q3:Q5 V <sub>CC</sub> , V <sub>CCO_LVCMOS</sub> = 3.465V		8		pF
		V <sub>CC</sub> , V <sub>CCO_LVCMOS</sub> = 2.625V		5		pF
R <sub>PULLUP</sub>	Input Pullup Resistor			51		kΩ
R <sub>PULLDOWN</sub>	Input Pulldown Resistor			51		kΩ
R <sub>OUT</sub>	Output Impedance	Q3:Q5 V <sub>CC</sub> , V <sub>CCO_LVCMOS</sub> = 3.465V		15		Ω
		Q3:Q5 V <sub>CC</sub> , V <sub>CCO_LVCMOS</sub> = 2.625V		20		Ω

**TABLE 3A. CONTROL INPUT FUNCTION TABLE**

Inputs			Outputs		
CLK_EN	CLK_SEL	Selected Source	Q0:Q2	nQ0:nQ2	Q3:Q5
0	0	CLK	Disabled; LOW	Disabled; HIGH	Disabled; LOW
0	1	XTAL_IN, XTAL_OUT	Disabled; LOW	Disabled; HIGH	Disabled; LOW
1	0	CLK	Enabled	Enabled	Enabled
1	1	XTAL_IN, XTAL_OUT	Enabled	Enabled	Enabled

After CLK\_EN switches, the clock outputs are disabled or enabled following a rising and falling input clock or crystal oscillator edge as shown in *Figure 1*.

In the active mode, the state of the outputs are a function of the CLK input as described in Table 3B.

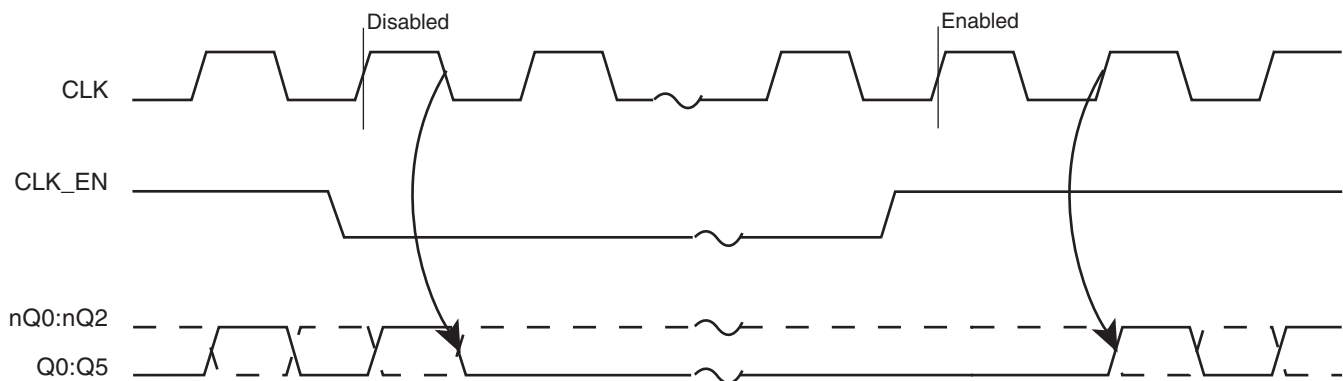

**FIGURE 1. CLK\_EN TIMING DIAGRAM**

**TABLE 3B. CLOCK INPUT FUNCTION TABLE**

Inputs	Outputs		
CLK	Q0:Q2	nQ0:nQ2	Q3:Q5
0	LOW	HIGH	LOW
1	HIGH	LOW	HIGH

## ABSOLUTE MAXIMUM RATINGS

Supply Voltage, $V_{CC}$	4.6V
Inputs, $V_i$ (LVCMOS)	-0.5V to $V_{CC} + 0.5V$
Outputs, $V_o$ (LVCMOS)	-0.5V to $V_{CCO\_LVCMOS} + 0.5V$
Inputs, $V_i$ (LVPECL)	-0.5V to $V_{CC} + 0.5V$
Outputs, $I_o$ (LVPECL)	
Continuous Current	50mA
Surge Current	100mA
Package Thermal Impedance, $\theta_{JA}$	91.1°C/W (0 mps)
Storage Temperature, $T_{STG}$	-65°C to 150°C

NOTE: Stresses beyond those listed under Absolute Maximum Ratings may cause permanent damage to the device. These ratings are stress specifications only. Functional operation of product at these conditions or any conditions beyond those listed in the *DC Characteristics* or *AC Characteristics* is not implied. Exposure to absolute maximum rating conditions for extended periods may affect product reliability.

**TABLE 4A. POWER SUPPLY DC CHARACTERISTICS,  $V_{CC} = V_{CCO\_LVPECL} = V_{CCO\_LVCMOS} = 3.3V \pm 5\%$ ,  $V_{EE} = 0V$ ,  $T_A = -40^\circ C$  TO  $85^\circ C$**

Symbol	Parameter	Test Conditions	Minimum	Typical	Maximum	Units
$V_{CC}$	Power Supply Voltage		3.135	3.3	3.465	V
$V_{CCO\_LVPECL}$ , $V_{CCO\_LVCMOS}$	Power Supply Voltage		3.135	3.3	3.465	V
$I_{EE}$	Power Supply Current				80	mA
$I_{CCO\_LVPECL}$	Power Supply Current				25	mA
$I_{CCO\_LVCMOS}$	Power Supply Current				45	mA

**TABLE 4B. POWER SUPPLY DC CHARACTERISTICS,  $V_{CC} = V_{CCO\_LVPECL} = V_{CCO\_LVCMOS} = 2.5V \pm 5\%$ ,  $V_{EE} = 0V$ ,  $T_A = -40^\circ C$  TO  $85^\circ C$**

Symbol	Parameter	Test Conditions	Minimum	Typical	Maximum	Units
$V_{CC}$	Power Supply Voltage		2.375	2.5	2.625	V
$V_{CCO\_LVPECL}$ , $V_{CCO\_LVCMOS}$	Power Supply Voltage		2.375	2.5	2.625	V
$I_{EE}$	Power Supply Current				80	mA
$I_{CCO\_LVPECL}$	Power Supply Current				30	mA
$I_{CCO\_LVCMOS}$	Power Supply Current				45	mA

**TABLE 4C. LVCMOS / LVTTTL DC CHARACTERISTICS,  $T_A = -40^{\circ}\text{C}$  TO  $85^{\circ}\text{C}$** 

Symbol	Parameter	Test Conditions	Minimum	Typical	Maximum	Units
$V_{IH}$	Input High Voltage	$V_{CC} = 3.3\text{V}$	2		$V_{CC} + 0.3$	V
		$V_{CC} = 2.5\text{V}$	1.7		$V_{CC} + 0.3$	V
$V_{IL}$	Input Low Voltage	$V_{CC} = 3.3\text{V}$	-0.3		0.8	V
		$V_{CC} = 2.5\text{V}$	-0.3		0.7	V
$V_{HYS}$	Input Hysteresis	CLK_EN, CLK_SEL	100			mV
$I_{IH}$	Input High Current	CLK	$V_{CC} = V_{IN} = 3.465\text{V}$ or $2.625\text{V}$		150	$\mu\text{A}$
		CLK_EN, CLK_SEL	$V_{CC} = V_{IN} = 3.465\text{V}$ or $2.625\text{V}$		5	$\mu\text{A}$
$I_{IL}$	Input Low Current	CLK	$V_{CC} = 3.465\text{V}$ or $2.625\text{V}$ , $V_{IN} = 0\text{V}$	-5		$\mu\text{A}$
		CLK_EN, CLK_SEL	$V_{CC} = 3.465\text{V}$ or $2.625\text{V}$ , $V_{IN} = 0\text{V}$	-150		$\mu\text{A}$
$V_{OH}$	Output High Voltage; NOTE 1	$V_{CCO\_LVCMOS} = 3.465\text{V}$	2.6			V
		$V_{CCO\_LVCMOS} = 2.625\text{V}$	1.8			V
$V_{OL}$	Output Low Voltage; NOTE 1	$V_{CCO\_LVCMOS} = 3.465$ or $2.625\text{V}$			0.5	V

NOTE 1: Outputs terminated with  $50\Omega$  to  $V_{CCO\_LVCMOS}/2$ . See Parameter Measurement Information Section. "LVCMOS Output Load Test circuit" diagrams.

**TABLE 4D. LVPECL DC CHARACTERISTICS,  $V_{CC} = V_{CCO\_LVPECL} = 3.3\text{V} \pm 5\%$ ,  $V_{EE} = 0\text{V}$ ,  $T_A = -40^{\circ}\text{C}$  TO  $85^{\circ}\text{C}$** 

Symbol	Parameter	Test Conditions	Minimum	Typical	Maximum	Units
$V_{OH}$	Output High Voltage; NOTE 1		$V_{CCO\_LVPECL} - 1.4$		$V_{CCO\_LVPECL} - 0.9$	V
$V_{OL}$	Output Low Voltage; NOTE 1		$V_{CCO\_LVPECL} - 2.0$		$V_{CCO\_LVPECL} - 1.7$	V
$V_{SWING}$	Peak-to-Peak Output Voltage Swing		0.6		1.0	V

NOTE 1: Outputs terminated with  $50\Omega$  to  $V_{CCO\_LVPECL} - 2\text{V}$ .

**TABLE 4E. LVPECL DC CHARACTERISTICS,  $V_{CC} = V_{CCO\_LVPECL} = 2.5\text{V} \pm 5\%$ ,  $V_{EE} = 0\text{V}$ ,  $T_A = -40^{\circ}\text{C}$  TO  $85^{\circ}\text{C}$** 

Symbol	Parameter	Test Conditions	Minimum	Typical	Maximum	Units
$V_{OH}$	Output High Voltage; NOTE 1		$V_{CCO\_LVPECL} - 1.4$		$V_{CCO\_LVPECL} - 0.9$	V
$V_{OL}$	Output Low Voltage; NOTE 1		$V_{CCO\_LVPECL} - 2.0$		$V_{CCO\_LVPECL} - 1.5$	V
$V_{SWING}$	Peak-to-Peak Output Voltage Swing		0.4		1.0	V

NOTE 1: Outputs terminated with  $50\Omega$  to  $V_{CCO\_LVPECL} - 2\text{V}$ .

**TABLE 5. CRYSTAL CHARACTERISTICS**

Parameter	Test Conditions	Minimum	Typical	Maximum	Units
Mode of Oscillation		Fundamental			
Frequency		12		40	MHz
Equivalent Series Resistance (ESR)				50	$\Omega$
Shunt Capacitance				7	pF
Drive Level				1	mW

**TABLE 6A. LVPECL AC CHARACTERISTICS,  $V_{CC} = V_{CCO\_LVPECL} = 3.3V \pm 5\%$ ,  $V_{EE} = 0V$ ,  $T_A = -40^\circ C$  TO  $85^\circ C$** 

Symbol	Parameter	Test Conditions	Minimum	Typical	Maximum	Units
$f_{MAX}$	Output Frequency				266	MHz
$t_{PD}$	Propagation Delay; NOTE 1		1.2		1.95	ns
$f_{jit}$	Buffer Additive Phase Jitter, RMS; refer to Additive Phase Jitter Section	155.52MHz, (Integration Range: 12kHz - 20MHz)		0.35		ps
$tsk(b)$	Bank Skew; NOTE 2, 5				55	ps
$tsk(o)$	Output Skew; NOTE 3, 5				80	ps
$tsk(pp)$	Part-to-Part Skew; NOTE 4, 5				800	ps
$t_R / t_F$	Output Rise/Fall Time	20% to 80%	250		600	ps
odc	Output Duty Cycle		46		54	%

All parameters measured at  $f \leq 266MHz$  unless noted otherwise.

NOTE 1: Measured from the  $V_{CC}/2$  of the input to the differential output crossing point.

NOTE 2: Defined as skew within a bank of outputs at the same voltage and with equal load conditions.

NOTE 3: Defined as skew between outputs at the same supply voltage and with equal load conditions.

Measured at the LVPECL output differential cross points.

NOTE 4: Defined as skew between outputs on different devices operating at the same supply voltage and with equal load conditions. Using the same type of inputs on each device, the outputs are measured at the LVPECL output differential cross points.

NOTE 5: This parameter is defined in accordance with JEDEC Standard 65.

**TABLE 6B. LVPECL AC CHARACTERISTICS,  $V_{CC} = V_{CCO\_LVPECL} = 2.5V \pm 5\%$ ,  $V_{EE} = 0V$ ,  $T_A = -40^\circ C$  TO  $85^\circ C$** 

Symbol	Parameter	Test Conditions	Minimum	Typical	Maximum	Units
$f_{MAX}$	Output Frequency				266	MHz
$t_{PD}$	Propagation Delay; NOTE 1		1.3		2	ns
$f_{jit}$	Buffer Additive Phase Jitter, RMS; refer to Additive Phase Jitter Section	155.52MHz, (Integration Range: 12kHz - 20MHz)		0.32		ps
$tsk(b)$	Bank Skew; NOTE 2, 5				65	ps
$tsk(o)$	Output Skew; NOTE 3, 5				80	ps
$tsk(pp)$	Part-to-Part Skew; NOTE 4, 5				425	ps
$t_R / t_F$	Output Rise/Fall Time	20% to 80%	250		800	ps
odc	Output Duty Cycle		46		54	%

All parameters measured at  $f \leq 266MHz$  unless noted otherwise.

NOTE 1: Measured from the  $V_{CC}/2$  of the input to the differential output crossing point.

NOTE 2: Defined as skew within a bank of outputs at the same voltage and with equal load conditions.

NOTE 3: Defined as skew between outputs at the same supply voltage and with equal load conditions.

Measured at the LVPECL output differential cross points.

NOTE 4: Defined as skew between outputs on different devices operating at the same supply voltage and with equal load conditions. Using the same type of inputs on each device, the outputs are measured at the LVPECL output differential cross points.

NOTE 5: This parameter is defined in accordance with JEDEC Standard 65.

**TABLE 6C. LVCMOS AC CHARACTERISTICS,  $V_{CC} = V_{CCO\_LVCMOS} = 3.3V \pm 5\%$ ,  $T_A = -40^\circ\text{C}$  TO  $85^\circ\text{C}$**

Symbol	Parameter	Test Conditions	Minimum	Typical	Maximum	Units
$f_{MAX}$	Output Frequency				266	MHz
$t_{PD}$	Propagation Delay; NOTE 1		2.4		3.5	ns
$f_{jit}$	Buffer Additive Phase Jitter, RMS; refer to Additive Phase Jitter Section	155.52MHz, (Integration Range: 12kHz - 20MHz)		0.35		ps
$t_{sk}(b)$	Bank Skew; NOTE 2, 5				65	ps
$t_{sk}(o)$	Output Skew; NOTE 3, 5				80	ps
$t_{sk}(pp)$	Part-to-Part Skew; NOTE 4, 5		0.730		800	ps
$t_R / t_F$	Output Rise/Fall Time	20% to 80%	0.3		1.15	ns
odc	Output Duty Cycle		46		54	%

All parameters measured at  $f \leq 266\text{MHz}$  unless noted otherwise.

NOTE 1: Measured from the  $V_{CC}/2$  of the input to  $V_{CCO\_LVCMOS}/2$  of the output.

NOTE 2: Defined as skew within a bank of outputs at the same voltage and with equal load conditions.

NOTE 3: Defined as skew between outputs at the same supply voltage and with equal load conditions.

Measured at  $V_{CCO\_LVCMOS}/2$ .

NOTE 4: Defined as skew between outputs on different devices operating at the same supply voltage and with equal load conditions. Using the same type of inputs on each device, the outputs are measured at  $V_{CCO\_LVCMOS}/2$ .

NOTE 5: This parameter is defined in accordance with JEDEC Standard 65.

**TABLE 6D. LVCMOS AC CHARACTERISTICS,  $V_{CC} = V_{CCO\_LVCMOS} = 2.5V \pm 5\%$ ,  $T_A = -40^\circ\text{C}$  TO  $85^\circ\text{C}$**

Symbol	Parameter	Test Conditions	Minimum	Typical	Maximum	Units
$f_{MAX}$	Output Frequency				266	MHz
$t_{PD}$	Propagation Delay; NOTE 1		2.5		3.75	ns
$f_{jit}$	Buffer Additive Phase Jitter, RMS; refer to Additive Phase Jitter Section	155.52MHz, (Integration Range: 12kHz - 20MHz)		0.32		ps
$t_{sk}(b)$	Bank Skew; NOTE 2, 5				75	ps
$t_{sk}(o)$	Output Skew; NOTE 3, 5				80	ps
$t_{sk}(pp)$	Part-to-Part Skew; NOTE 4, 5				800	ps
$t_R / t_F$	Output Rise/Fall Time	20% to 80%	0.425		1.85	ns
odc	Output Duty Cycle		46		54	%

All parameters measured at  $f \leq 266\text{MHz}$  unless noted otherwise.

NOTE 1: Measured from the  $V_{CC}/2$  of the input to  $V_{CCO\_LVCMOS}/2$  of the output.

NOTE 2: Defined as skew within a bank of outputs at the same voltage and with equal load conditions.

NOTE 3: Defined as skew between outputs at the same supply voltage and with equal load conditions.

Measured at  $V_{CCO\_LVCMOS}/2$ .

NOTE 4: Defined as skew between outputs on different devices operating at the same supply voltage and with equal load conditions. Using the same type of inputs on each device, the outputs are measured at  $V_{CCO\_LVCMOS}/2$ .

NOTE 5: This parameter is defined in accordance with JEDEC Standard 65.

# PARAMETER MEASUREMENT INFORMATION

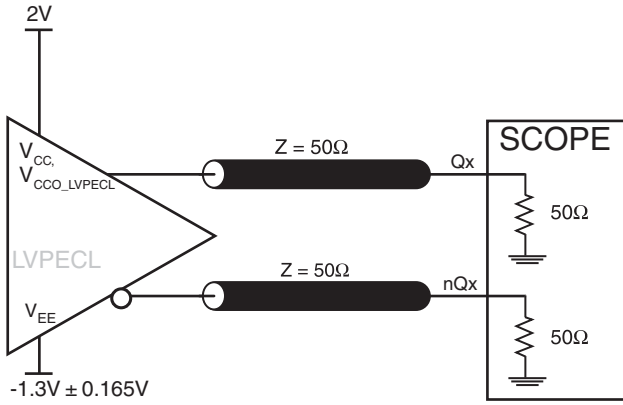

3.3V LVPECL OUTPUT LOAD AC TEST CIRCUIT

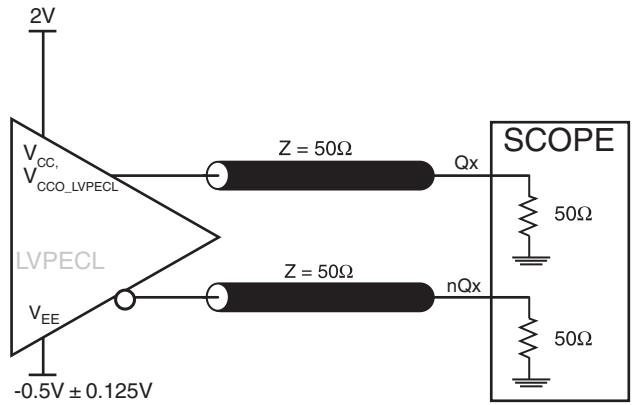

2.5V LVPECL OUTPUT LOAD AC TEST CIRCUIT

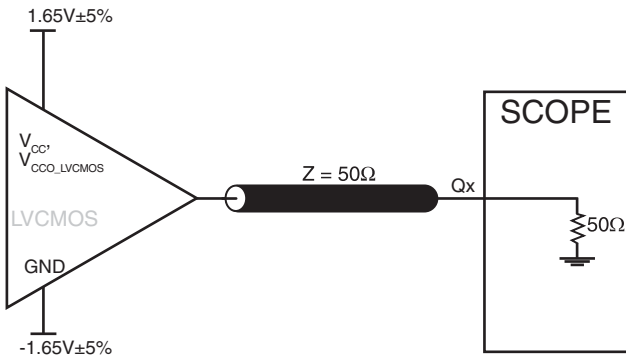

3.3V LVCMOS OUTPUT LOAD AC TEST CIRCUIT

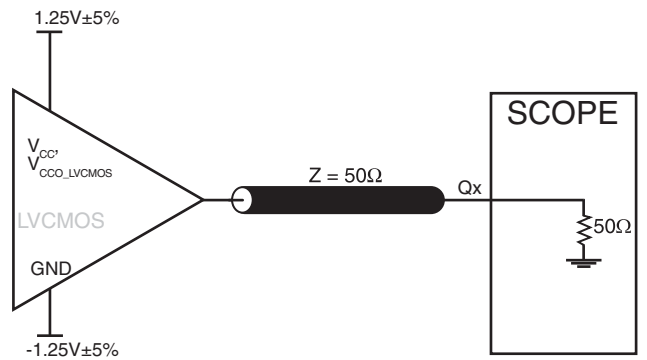

2.5V LVCMOS OUTPUT LOAD AC TEST CIRCUIT

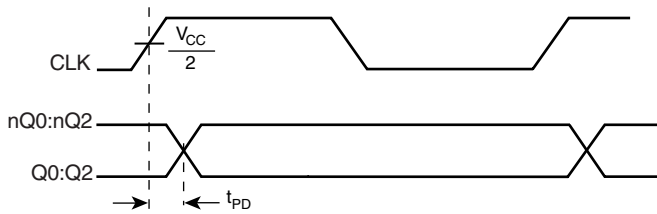

LVPECL PROPAGATION DELAY

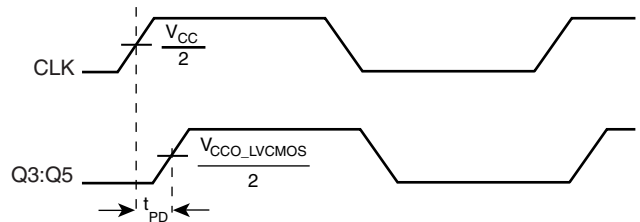

LVCMOS PROPAGATION DELAY

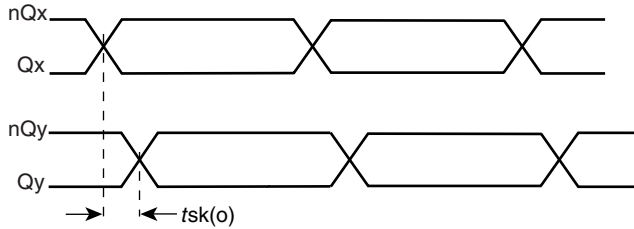

**LVPECL OUTPUT SKEW**

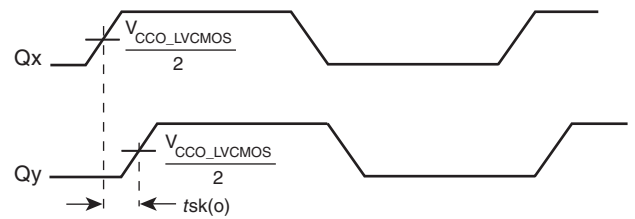

**LVCMOS OUTPUT SKEW**

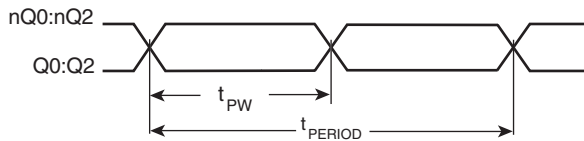

$$\text{odc} = \frac{t_{PW}}{t_{PERIOD}} \times 100\%$$

**LVPECL OUTPUT DUTY CYCLE/PULSE WIDTH/PERIOD**

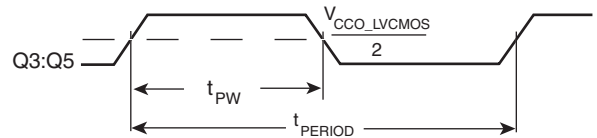

$$\text{odc} = \frac{t_{PW}}{t_{PERIOD}} \times 100\%$$

**LVCMOS OUTPUT DUTY CYCLE/PULSE WIDTH/PERIOD**

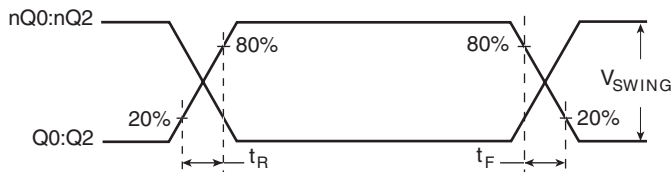

**LVPECL OUTPUT RISE/FALL TIME**

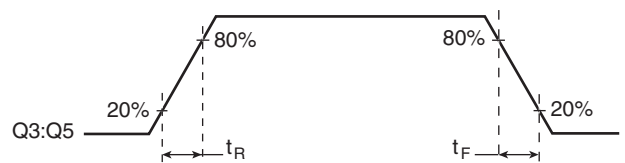

**LVCMOS OUTPUT RISE/FALL TIME**

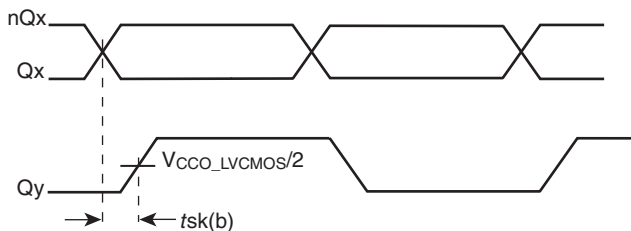

**BANK SKEW**

# APPLICATION INFORMATION

## RECOMMENDATIONS FOR UNUSED INPUT AND OUTPUT PINS

### INPUTS:

#### CRYSTAL INPUTS

For applications not requiring the use of the crystal oscillator input, both XTAL\_IN and XTAL\_OUT can be left floating. Though not required, but for additional protection, a 1k $\Omega$  resistor can be tied from XTAL\_IN to ground.

#### CLK INPUT

For applications not requiring the use of a clock input, it can be left floating. Though not required, but for additional protection, a 1k $\Omega$  resistor can be tied from the CLK input to ground.

#### LVC MOS CONTROL PINS

All control pins have internal pull-ups or pull-downs; additional resistance is not required but can be added for additional protection. A 1k $\Omega$  resistor can be used.

### OUTPUTS:

#### LVC MOS OUTPUTS

All unused LVC MOS output can be left floating. There should be no trace attached.

#### LVPECL OUTPUTS

All unused LVPECL outputs can be left floating. We recommend that there is no trace attached. Both sides of the differential output pair should either be left floating or terminated.

---

---

## CRYSTAL INPUT INTERFACE

The ICS8536I-33 has been characterized with 18pF parallel resonant crystals. The capacitor values, C1 and C2, shown in *Figure 2* below were determined using an 18pF parallel resonant crystal and were chosen to minimize the ppm error. These

same capacitor values will tune any 18pF parallel resonant crystal over the frequency range and other parameters specified in this data sheet. The optimum C1 and C2 values can be slightly adjusted for different board layouts.

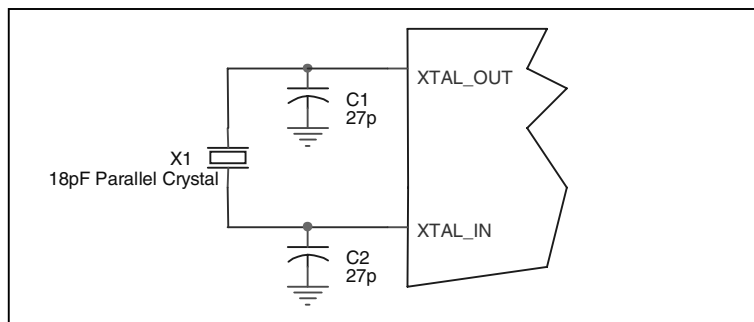

FIGURE 2. CRYSTAL INPUT INTERFACE

### LVC MOS TO XTAL INTERFACE

The XTAL\_IN input can accept a single-ended LVC MOS signal through an AC coupling capacitor. A general interface diagram is shown in *Figure 3*. The XTAL\_OUT pin can be left floating. The input edge rate can be as slow as 10ns. For LVC MOS inputs, it is recommended that the amplitude be reduced from full swing to half swing in order to prevent signal interference with the power rail and to reduce noise. This configuration requires that the output

impedance of the driver ( $R_o$ ) plus the series resistance ( $R_s$ ) equals the transmission line impedance. In addition, matched termination at the crystal input will attenuate the signal in half. This can be done in one of two ways. First,  $R_1$  and  $R_2$  in parallel should equal the transmission line impedance. For most  $50\Omega$  applications,  $R_1$  and  $R_2$  can be  $100\Omega$ . This can also be accomplished by removing  $R_1$  and making  $R_2$   $50\Omega$ .

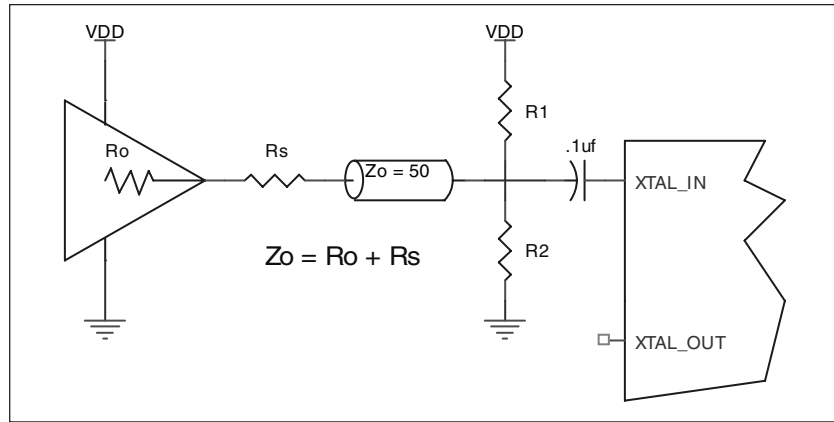

FIGURE 3. GENERAL DIAGRAM FOR LVC MOS DRIVER TO XTAL INPUT INTERFACE

### TERMINATION FOR 3.3V LVPECL OUTPUTS

The clock layout topology shown below is a typical termination for LVPECL outputs. The two different layouts mentioned are recommended only as guidelines.

FOUT and nFOUT are low impedance follower outputs that generate ECL/LVPECL compatible outputs. Therefore, terminating resistors (DC current path to ground) or current sources must be used for functionality. These outputs are designed to

drive  $50\Omega$  transmission lines. Matched impedance techniques should be used to maximize operating frequency and minimize signal distortion. *Figures 4A and 4B* show two different layouts which are recommended only as guidelines. Other suitable clock layouts may exist and it would be recommended that the board designers simulate to guarantee compatibility across all printed circuit and clock component process variations.

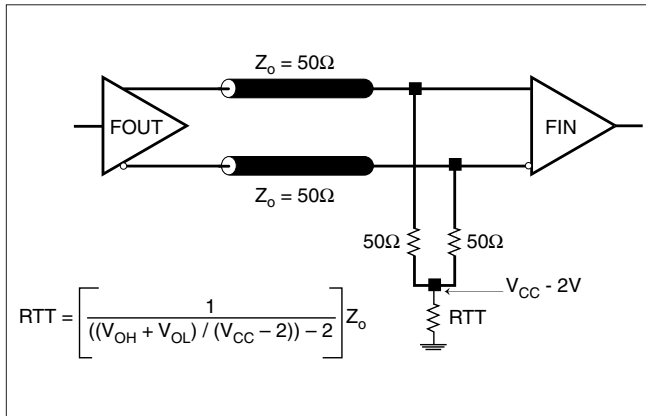

FIGURE 4A. LVPECL OUTPUT TERMINATION

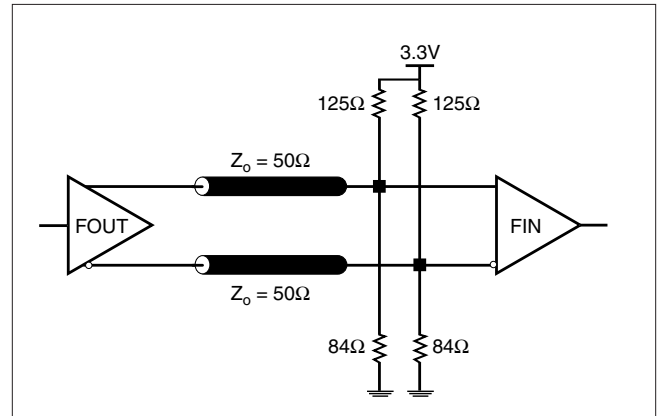

FIGURE 4B. LVPECL OUTPUT TERMINATION

## TERMINATION FOR 2.5V LVPECL OUTPUTS

Figure 5A and Figure 5B show examples of termination for 2.5V LVPECL driver. These terminations are equivalent to terminating  $50\Omega$  to  $V_{CC} - 2V$ . For  $V_{CC} = 2.5V$ , the  $V_{CC} - 2V$  is

very close to  $\_LVCMOS$ ground level. The R3 in Figure 5B can be eliminated and the termination is shown in Figure 5C.

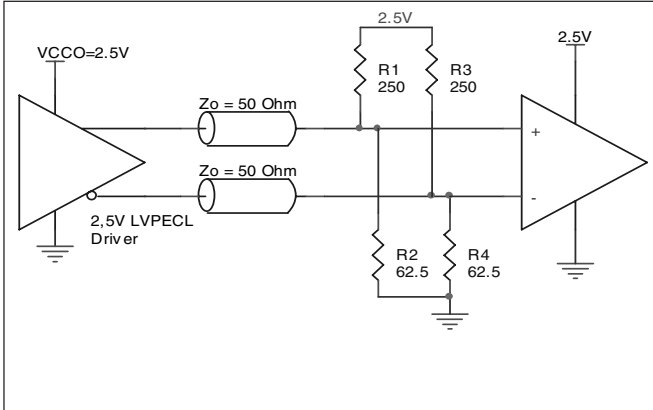

FIGURE 5A. 2.5V LVPECL DRIVER TERMINATION EXAMPLE

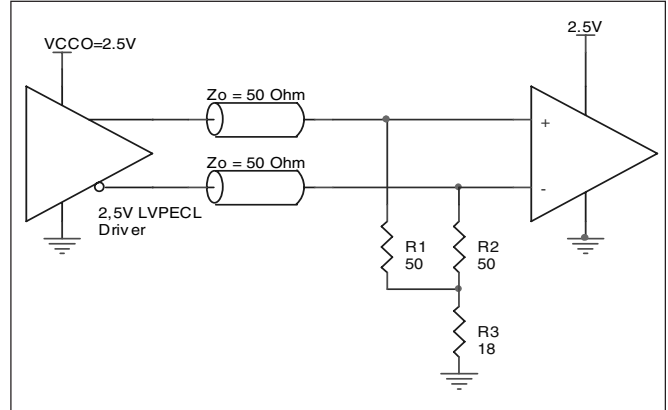

FIGURE 5B. 2.5V LVPECL DRIVER TERMINATION EXAMPLE

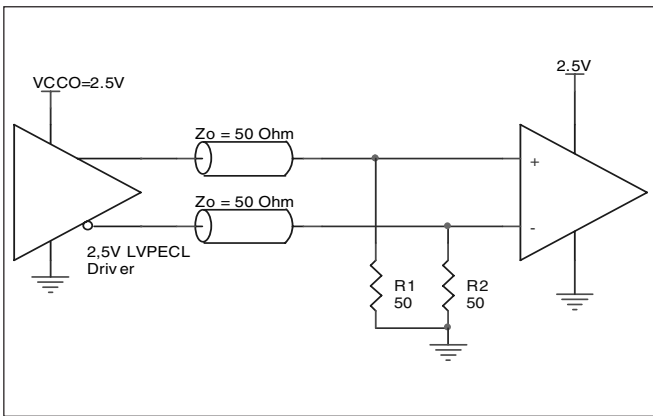

FIGURE 5C. 2.5V LVPECL TERMINATION EXAMPLE

# POWER CONSIDERATIONS

This section provides information on power dissipation and junction temperature for the ICS8536I-33. Equations and example calculations are also provided.

## 1. Power Dissipation.

The total power dissipation for the ICS8536I-33 is the sum of the core power plus the power dissipated in the load(s). The following is the power dissipation for  $V_{CC} = 3.3V + 5\% = 3.465V$ , which gives worst case results.

**NOTE:** Please refer to Section 3 for details on calculating power dissipated in the load.

### Core and LVPECL Output Power Dissipation

- Power (core)<sub>MAX</sub> =  $V_{CC\_MAX} * I_{EE\_MAX} = 3.465V * 80mA = 277.2mW$
- Power (outputs)<sub>MAX</sub> = **30mW/Loaded Output pair**  
If all outputs are loaded, the total power is  $3 * 30mW = 90mW$

### LVC MOS Output Power Dissipation

- Output Impedance  $R_{OUT}$  Power Dissipation due to Loading  $50\Omega$  to  $V_{CCO\_LVC MOS} / 2$   
Output Current  $I_{OUT} = V_{CCO\_MAX} / [2 * (50\Omega + R_{OUT})] = 3.465V / [2 * (50\Omega + 15\Omega)] = 26.7mA$
- Power Dissipation on the  $R_{OUT}$  per LVC MOS output  
Power ( $R_{OUT}$ ) =  $R_{OUT} * (I_{OUT})^2 = 15\Omega * (26.7mA)^2 = 10.7mW$  per output
- Total Power Dissipation on the  $R_{OUT}$   
**Total Power ( $R_{OUT}$ ) =  $10.7mW * 3 = 32.1mW$**

### Total Power Dissipation

- **Total Power**  
= Power (LVPECL) + Total Power ( $R_{OUT}$ )  
=  $277.2mW + 90mW + 32.1mW$   
= **399.3mW**

## 2. Junction Temperature.

Junction temperature, T<sub>j</sub>, is the temperature at the junction of the bond wire and bond pad and directly affects the reliability of the device. The maximum recommended junction temperature for HiPerClockS™ devices is 125°C.

The equation for T<sub>j</sub> is as follows:  $T_j = \theta_{JA} * Pd_{total} + T_A$

T<sub>j</sub> = Junction Temperature

$\theta_{JA}$  = Junction-to-Ambient Thermal Resistance

Pd<sub>total</sub> = Total Device Power Dissipation (example calculation is in section 1 above)

T<sub>A</sub> = Ambient Temperature

In order to calculate junction temperature, the appropriate junction-to-ambient thermal resistance  $\theta_{JA}$  must be used. Assuming no air flow and a multi-layer board, the appropriate value is 91.1°C/W per Table 7 below.

Therefore, T<sub>j</sub> for an ambient temperature of 85°C with all outputs switching is:

$85^\circ\text{C} + 0.3993\text{W} * 91.1^\circ\text{C}/\text{W} = 121.4^\circ\text{C}$ . This is below the limit of 125°C.

This calculation is only an example. T<sub>j</sub> will obviously vary depending on the number of loaded outputs, supply voltage, air flow, and the type of board (single layer or multi-layer).

**TABLE 7. THERMAL RESISTANCE  $\theta_{JA}$  FOR 20-PIN TSSOP, FORCED CONVECTION**

<b><math>\theta_{JA}</math> by Velocity (Linear Feet per Minute)</b>			
	<b>0</b>	<b>200</b>	<b>500</b>
Multi-Layer PCB, JEDEC Standard Test Boards	91.1°C/W	86.7°C/W	84.6°C/W

### 3. Calculations and Equations.

The purpose of this section is to derive the power dissipated into the load.

LVPECL output driver circuit and termination are shown in *Figure 6*.

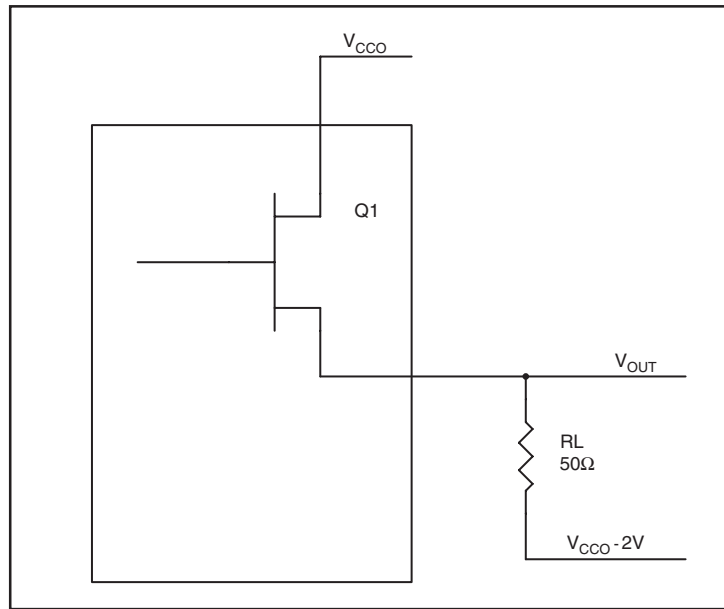

**FIGURE 6. LVPECL DRIVER CIRCUIT AND TERMINATION**

To calculate worst case power dissipation into the load, use the following equations which assume a 50Ω load, and a termination voltage of  $V_{CCO} - 2V$ .

- For logic high,  $V_{OUT} = V_{OH\_MAX} = V_{CCO\_MAX} - 0.9V$   
 $(V_{CCO\_MAX} - V_{OH\_MAX}) = 0.9V$
- For logic low,  $V_{OUT} = V_{OL\_MAX} = V_{CCO\_MAX} - 1.7V$   
 $(V_{CCO\_MAX} - V_{OL\_MAX}) = 1.7V$

$Pd\_H$  is power dissipation when the output drives high.  
 $Pd\_L$  is the power dissipation when the output drives low.

$$Pd\_H = [(V_{OH\_MAX} - (V_{CCO\_MAX} - 2V))/R_L] * (V_{CCO\_MAX} - V_{OH\_MAX}) = [(2V - (V_{CCO\_MAX} - V_{OH\_MAX}))/R_L] * (V_{CCO\_MAX} - V_{OH\_MAX}) = [(2V - 0.9V)/50\Omega] * 0.9V = \mathbf{19.8mW}$$

$$Pd\_L = [(V_{OL\_MAX} - (V_{CCO\_MAX} - 2V))/R_L] * (V_{CCO\_MAX} - V_{OL\_MAX}) = [(2V - (V_{CCO\_MAX} - V_{OL\_MAX}))/R_L] * (V_{CCO\_MAX} - V_{OL\_MAX}) = [(2V - 1.7V)/50\Omega] * 1.7V = \mathbf{10.2mW}$$

Total Power Dissipation per output pair =  $Pd\_H + Pd\_L = \mathbf{30mW}$

# RELIABILITY INFORMATION

TABLE 8.  $\theta_{JA}$  VS. AIR FLOW TABLE FOR 20 LEAD TSSOP

$\theta_{JA}$ by Velocity (Meters per Second)			
	0	1	2.5
Multi-Layer PCB, JEDEC Standard Test Boards	91.1°C/W	86.7°C/W	84.6°C/W

## TRANSISTOR COUNT

The transistor count for ICS8536I-33 is: 550

# PACKAGE OUTLINE & PACKAGE DIMENSIONS

PACKAGE OUTLINE - G SUFFIX FOR 20 LEAD TSSOP

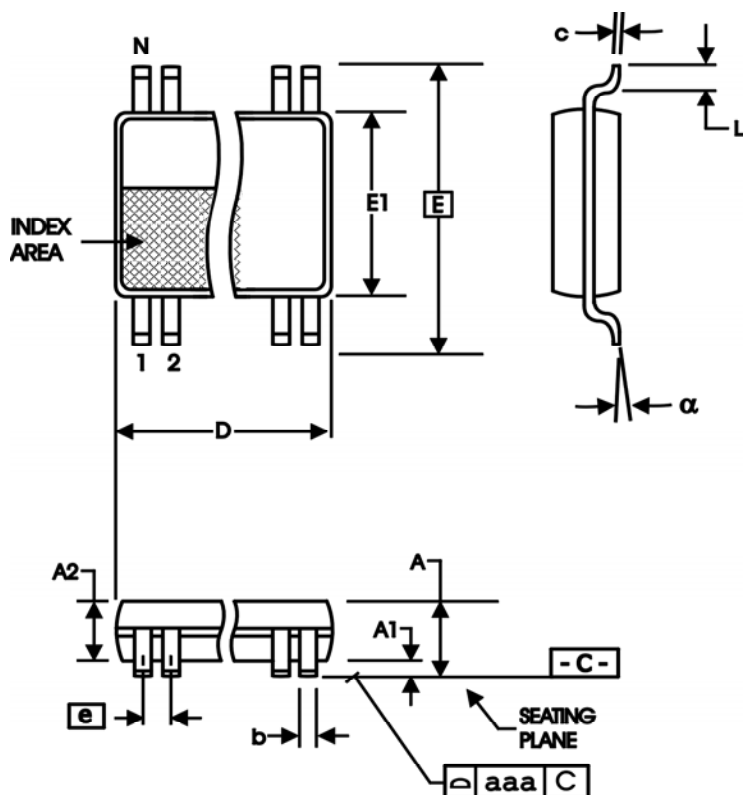

TABLE 9. PACKAGE DIMENSIONS

SYMBOL	Millimeters	
	MIN	MAX
N	20	
A	--	1.20
A1	0.05	0.15
A2	0.80	1.05
b	0.19	0.30
c	0.09	0.20
D	6.40	6.60
E	6.40 BASIC	
E1	4.30	4.50
e	0.65 BASIC	
L	0.45	0.75
$\alpha$	0°	8°
aaa	--	0.10

Reference Document: JEDEC Publication 95, MO-153

**TABLE 10. ORDERING INFORMATION**

<b>Part/Order Number</b>	<b>Marking</b>	<b>Package</b>	<b>Shipping Packaging</b>	<b>Temperature</b>
8536CGI-33	ICS8536CGI33	20 lead TSSOP	tube	-40°C to 85°C
8536CGI-33T	ICS8536CGI33	20 lead TSSOP	2500 tape & reel	-40°C to 85°C
8536CGI-33LF	ICS8536CI33L	20 lead "Lead-Free" TSSOP	tube	-40°C to 85°C
8536CGI-33LFT	ICS8536CI33L	20 lead "Lead-Free" TSSOP	2500 tape & reel	-40°C to 85°C

NOTE: Parts that are ordered with an "LF" suffix to the part number are the Pb-Free configuration and are RoHS compliant.

While the information presented herein has been checked for both accuracy and reliability, Integrated Device Technology, Incorporated (IDT) assumes no responsibility for either its use or for infringement of any patents or other rights of third parties, which would result from its use. No other circuits, patents, or licenses are implied. This product is intended for use in normal commercial and industrial applications. Any other applications such as those requiring high reliability or other extraordinary environmental requirements are not recommended without additional processing by IDT. IDT reserves the right to change any circuitry or specifications without notice. IDT does not authorize or warrant any IDT product for use in life support devices or critical medical instruments.

**REVISION HISTORY SHEET**

<b>Rev</b>	<b>Table</b>	<b>Page</b>	<b>Description of Change</b>	<b>Date</b>
B	T1	1	Pin Assignment - corrected pins 13 & 14.	6/25/08
		2	Pin Description Table - corrected pin 13 & 14.	

**Innovate with IDT and accelerate your future networks. Contact:**

**www.IDT.com**

**For Sales**

800-345-7015 (inside USA)  
+408-284-8200 (outside USA)  
Fax: 408-284-2775  
[www.IDT.com/go/contactIDT](http://www.IDT.com/go/contactIDT)

**For Tech Support**

[netcom@idt.com](mailto:netcom@idt.com)  
+480-763-2056

**Corporate Headquarters**

Integrated Device Technology, Inc.  
6024 Silver Creek Valley Road  
San Jose, CA 95138  
United States  
800-345-7015 (inside USA)  
+408-284-8200 (outside USA)

