



ICS85310I-21

LOW SKEW, DUAL, 1-TO-5 DIFFERENTIAL-TO-2.5V/3.3V ECL/LVPECL FANOUT BUFFER

GENERAL DESCRIPTION

The ICS85310I-21 is a low skew, high performance dual 1-to-5 Differential-to-2.5V/3.3V ECL/LVPECL Fanout Buffer. The CLKx, nCLKx pairs can accept most standard differential input levels. The ICS85310I-21 is characterized to operate from either a 2.5V or a 3.3V power supply. Guaranteed output and part-to-part skew characteristics make the ICS85310I-21 ideal for those clock distribution applications demanding well defined performance and repeatability.

FEATURES

- Two differential 2.5V/3.3V LVPECL / ECL bank outputs
- Two differential clock input pairs
- CLKx, nCLKx pairs can accept the following differential input levels: LVDS, LVPECL, LVHSTL, SSTL, HCSL
- Maximum output frequency: 700MHz
- Translates any single ended input signal to 3.3V LVPECL levels with resistor bias on nCLKx input
- Output skew: 25ps (typical)
- Part-to-part skew: 270ps (typical)
- Propagation delay: 1.7ns (typical)
- Additive phase jitter, RMS: <0.13ps (typical)
- LVPECL mode operating voltage supply range: $V_{CC} = 2.375V$ to $3.8V$, $V_{EE} = 0V$
- ECL mode operating voltage supply range: $V_{CC} = 0V$, $V_{EE} = -3.8V$ to $-2.375V$
- $-40^{\circ}C$ to $85^{\circ}C$ ambient operating temperature
- Lead-Free package fully RoHS compliant

BLOCK DIAGRAM

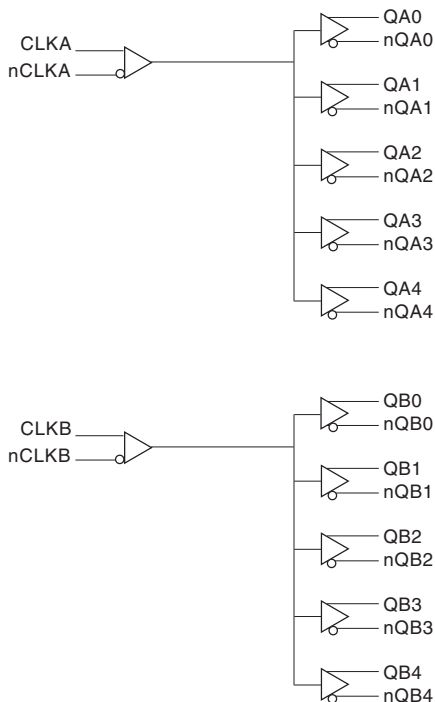

PIN ASSIGNMENT

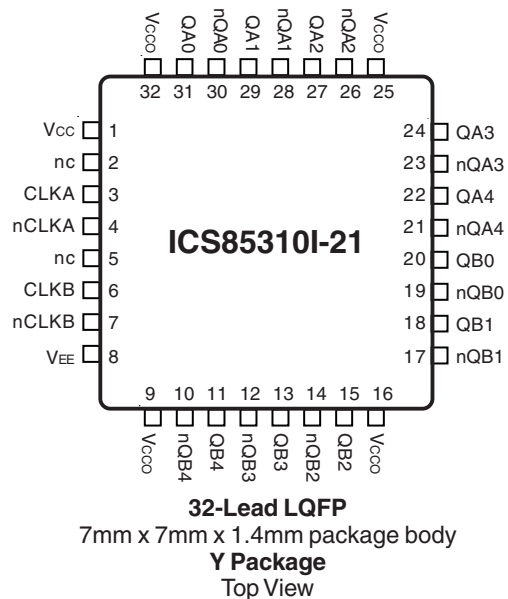



ICS85310I-21

LOW SKEW, DUAL, 1-TO-5
DIFFERENTIAL-TO-2.5V/3.3V ECL/LVPECL FANOUT BUFFER

TABLE 1. PIN DESCRIPTIONS

Number	Name	Type		Description
1	V _{CC}	Power		Core supply pin.
2, 5	nc	Unused		No connect.
3	CLKA	Input	Pulldown	Non-inverting differential clock input.
4	nCLKA	Input	Pullup	Inverting differential clock input.
6	CLKB	Input	Pulldown	Non-inverting differential clock input.
7	nCLKB	Input	Pullup	Inverting differential clock input.
8	V _{EE}	Power		Negative supply pin.
9, 16, 25, 32	V _{CCO}	Power		Output supply pins.
10, 11	nQB4, QB4	Output		Differential output pair. LVPECL interface levels.
12, 13	nQB3, QB3	Output		Differential output pair. LVPECL interface levels.
14, 15	nQB2, QB2	Output		Differential output pair. LVPECL interface levels.
17, 18	nQB1, QB1	Output		Differential output pair. LVPECL interface levels.
19, 20	nQB0, QB0	Output		Differential output pair. LVPECL interface levels.
21, 22	nQA4, QA4	Output		Differential output pair. LVPECL interface levels.
23, 24	nQA3, QA3	Output		Differential output pair. LVPECL interface levels.
26, 27	nQA2, QA2	Output		Differential output pair. LVPECL interface levels.
28, 29	nQA1, QA1	Output		Differential output pair. LVPECL interface levels.
30, 31	nQA0, QA0	Output		Differential output pair. LVPECL interface levels.

NOTE: *Pullup* and *Pulldown* refer to internal input resistors. See Table 2, Pin Characteristics, for typical values.

TABLE 2. PIN CHARACTERISTICS

Symbol	Parameter	Test Conditions	Minimum	Typical	Maximum	Units
C _{IN}	Input Capacitance			4		pF
R _{PULLUP}	Input Pullup Resistor			51		kΩ
R _{PULLDOWN}	Input Pulldown Resistor			51		kΩ

TABLE 3. CLOCK INPUT FUNCTION TABLE

Inputs		Outputs		Input to Output Mode	Polarity
CLKA or CLKB	nCLKA or nCLKB	QA0:QA4, QB0:QB4	nQA0:nQA4, nQB0:nQB4		
0	1	LOW	HIGH	Differential to Differential	Non Inverting
1	0	HIGH	LOW	Differential to Differential	Non Inverting
0	Biased; NOTE 1	LOW	HIGH	Single Ended to Differential	Non Inverting
1	Biased; NOTE 1	HIGH	LOW	Single Ended to Differential	Non Inverting
Biased; NOTE 1	0	HIGH	LOW	Single Ended to Differential	Inverting
Biased; NOTE 1	1	LOW	HIGH	Single Ended to Differential	Inverting

NOTE 1: Please refer to the Application Information, "Wiring the Differential Input to Accept Single Ended Levels".



ICS85310I-21

LOW SKEW, DUAL, 1-TO-5 DIFFERENTIAL-TO-2.5V/3.3V ECL/LVPECL FANOUT BUFFER

ABSOLUTE MAXIMUM RATINGS

Supply Voltage, V_{CC}	4.6V
Negative Supply Voltage, V_{EE}	-4.6V
Inputs, V_I	-0.5V to $V_{CC} + 0.5V$
Outputs, I_O	
Continuous Current	50mA
Surge Current	100mA
Operating Temperature Range, T_A	-40°C to +85°C
Storage Temperature, T_{STG}	-65°C to 150°C
Package Thermal Impedance, θ_{JA} (Junction-to-Ambient)	47.9°C/W (0 lfpm)

NOTE: Stresses beyond those listed under Absolute Maximum Ratings may cause permanent damage to the device. These ratings are stress specifications only. Functional operation of product at these conditions or any conditions beyond those listed in the *DC Characteristics* or *AC Characteristics* is not implied. Exposure to absolute maximum rating conditions for extended periods may affect product reliability.

TABLE 4A. POWER SUPPLY DC CHARACTERISTICS, $V_{CC} = V_{CCO} = 2.375V$ TO $3.8V$, $T_A = -40^\circ C$ TO $85^\circ C$

Symbol	Parameter	Test Conditions	Minimum	Typical	Maximum	Units
V_{CC}	Core Supply Voltage		2.375	3.3	3.8	V
V_{CCO}	Output Supply Voltage		2.375	3.3	3.8	V
I_{EE}	Power Supply Current				120	mA

TABLE 4B. DIFFERENTIAL DC CHARACTERISTICS, $V_{CC} = V_{CCO} = 2.375V$ TO $3.8V$, $T_A = -40^\circ C$ TO $85^\circ C$

Symbol	Parameter	Test Conditions	Minimum	Typical	Maximum	Units
I_{IH}	Input High Current	CLKA, CLKB	$V_{CC} = V_{IN} = 3.8V$		150	μA
		nCLKA, nCLKB	$V_{CC} = V_{IN} = 3.8V$		5	μA
I_{IL}	Input Low Current	CLKA, CLKB	$V_{CC} = 3.8V, V_{IN} = 0V$	-5		μA
		nCLKA, nCLKB	$V_{CC} = 3.8V, V_{IN} = 0V$	-150		μA
V_{PP}	Peak-to-Peak Input Voltage		0.15		1.3	V
V_{CMR}	Common Mode Input Voltage; NOTE 1, 2		$V_{EE} + 0.5$		$V_{CC} - 0.85$	V

NOTE 1: Common mode voltage is defined as V_{IH} .

NOTE 2: For single ended applications, the maximum input voltage for CLKA, nCLKA and CLKB, nCLKB is $V_{CC} + 0.3V$.

TABLE 4C. LVPECL DC CHARACTERISTICS, $V_{CC} = V_{CCO} = 2.375V$ TO $3.8V$, $T_A = -40^\circ C$ TO $85^\circ C$

Symbol	Parameter	Test Conditions	Minimum	Typical	Maximum	Units
V_{OH}	Output High Voltage; NOTE 1		$V_{CCO} - 1.4$		$V_{CCO} - 0.9$	V
V_{OL}	Output Low Voltage; NOTE 1		$V_{CCO} - 2.0$		$V_{CCO} - 1.7$	V
V_{SWING}	Peak-to-Peak Output Voltage Swing		0.6		1.0	V

NOTE 1: Outputs terminated with 50Ω to $V_{CCO} - 2V$.



ICS85310I-21

LOW SKEW, DUAL, 1-TO-5
DIFFERENTIAL-TO-2.5V/3.3V ECL/LVPECL FANOUT BUFFER

TABLE 5. AC CHARACTERISTICS, $V_{CC} = V_{CCO} = 2.375V$ TO $3.8V$, $T_A = -40^{\circ}C$ TO $85^{\circ}C$

Symbol	Parameter	Test Conditions	Minimum	Typical	Maximum	Units
f_{MAX}	Output Frequency				700	MHz
t_{PD}	Propagation Delay; NOTE 1	$f \leq 500MHz$		1.7	2.2	ns
$t_{sk(o)}$	Output Skew; NOTE 2, 4			25	50	ps
$t_{sk(pp)}$	Part-to-Part Skew; NOTE 3, 4			270	550	ps
f_{jit}	Buffer Additive Phase Jitter, RMS; refer to Additive Phase Jitter Section			<0.13		ps
t_R	Output Rise Time	20% to 80%	200		700	ps
t_F	Output Fall Time	20% to 80%	200		700	ps
odc	Output Duty Cycle		47		53	%

All parameters measured at 500MHz unless noted otherwise.

NOTE 1: Measured from the differential input crossing point to the differential output crossing point.

NOTE 2: Defined as skew between outputs at the same supply voltage and with equal load conditions. Measured at the output differential cross points.

NOTE 3: Defined as skew between outputs on different devices operating at the same supply voltages and with equal load conditions. Using the same type of inputs on each device, the outputs are measured at the differential cross points.

NOTE 4: This parameter is defined in accordance with JEDEC Standard 65.



ADDITIVE PHASE JITTER

The spectral purity in a band at a specific offset from the fundamental compared to the power of the fundamental is called the ***dBc Phase Noise***. This value is normally expressed using a Phase noise plot and is most often the specified plot in many applications. Phase noise is defined as the ratio of the noise power present in a 1Hz band at a specified offset from the fundamental frequency to the power value of the fundamental. This ratio is expressed in decibels (dBm) or a ratio of the power in

the 1Hz band to the power in the fundamental. When the required offset is specified, the phase noise is called a ***dBc*** value, which simply means dBm at a specified offset from the fundamental. By investigating jitter in the frequency domain, we get a better understanding of its effects on the desired application over the entire time record of the signal. It is mathematically possible to calculate an expected bit error rate given a phase noise plot.

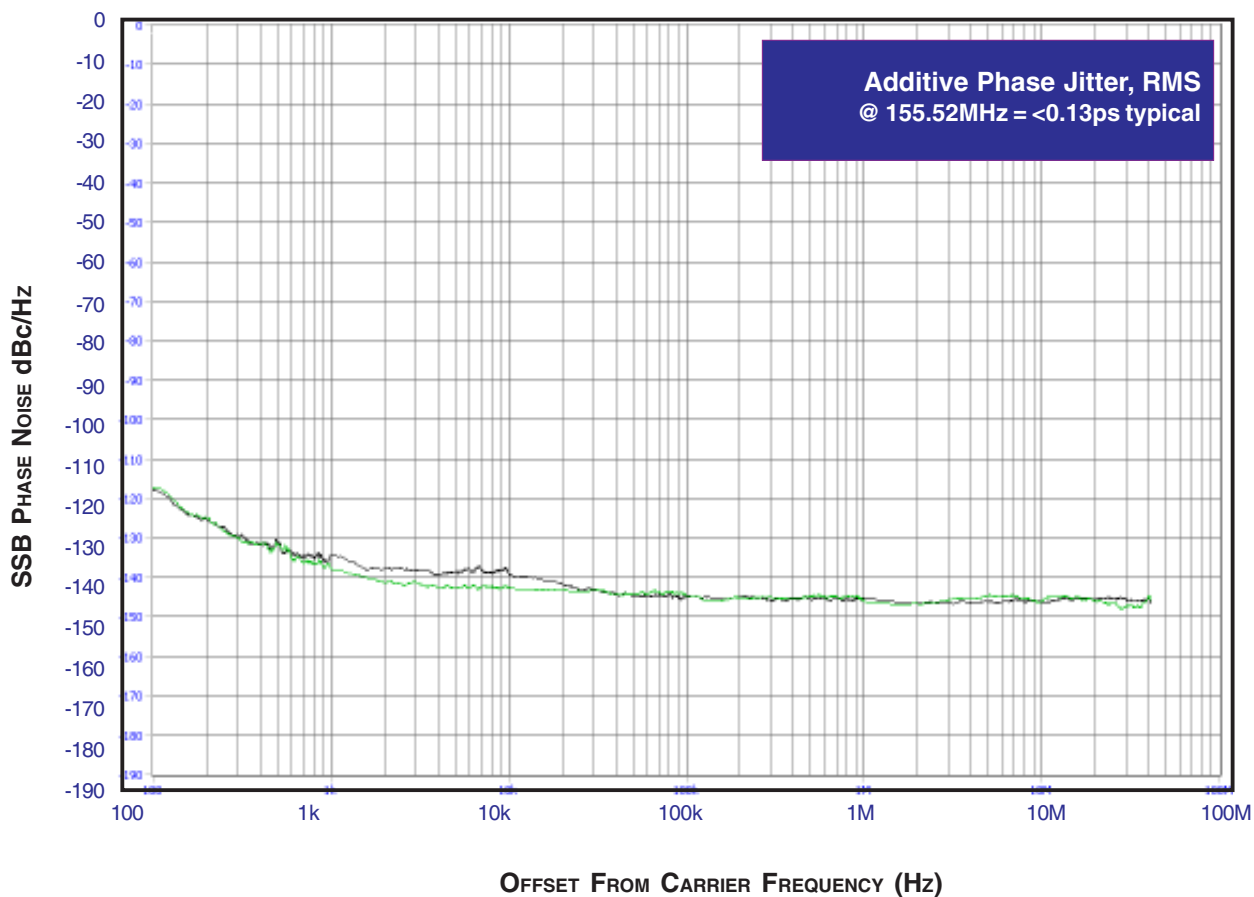

As with most timing specifications, phase noise measurements have issues. The primary issue relates to the limitations of the equipment. Often the noise floor of the equipment is higher than the noise floor of the device. This is illustrated above. The de-

vice meets the noise floor of what is shown, but can actually be lower. The phase noise is dependant on the input source and measurement equipment.

PARAMETER MEASUREMENT INFORMATION

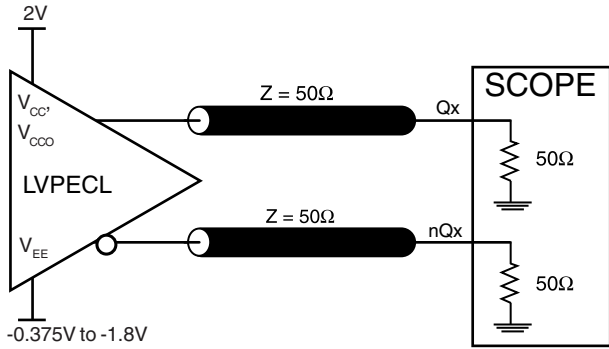

3.3V OUTPUT LOAD AC TEST CIRCUIT

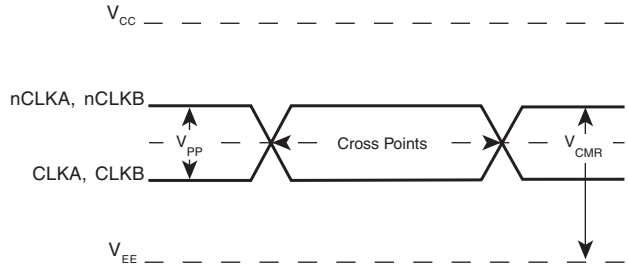

DIFFERENTIAL INPUT LEVEL

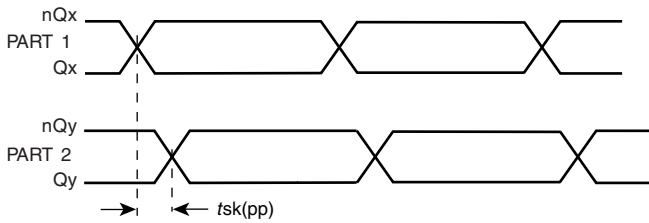

PART-TO-PART SKEW

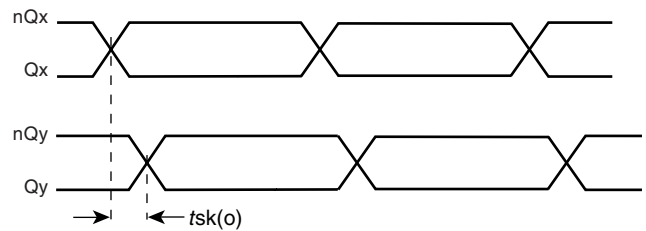

OUTPUT SKEW

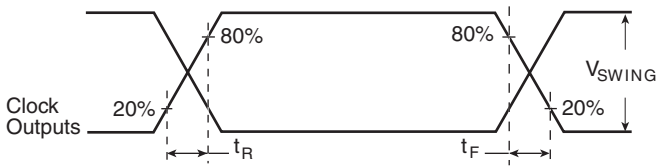

OUTPUT RISE/FALL TIME

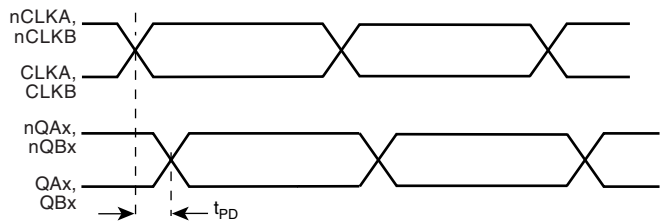

PROPAGATION DELAY

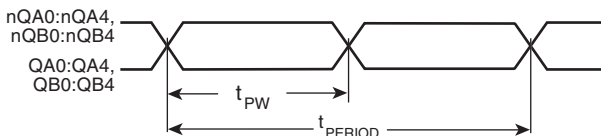

$$odc = \frac{t_{PW}}{t_{PERIOD}} \times 100\%$$

OUTPUT DUTY CYCLE/PULSE WIDTH/PERIOD

APPLICATION INFORMATION

WIRING THE DIFFERENTIAL INPUT TO ACCEPT SINGLE ENDED LEVELS

Figure 1 shows how the differential input can be wired to accept single ended levels. The reference voltage $V_{REF} \approx V_{CC}/2$ is generated by the bias resistors R1, R2 and C1. This bias circuit should be located as close as possible to the input pin. The ratio

of R1 and R2 might need to be adjusted to position the V_{REF} in the center of the input voltage swing. For example, if the input clock swing is only 2.5V and $V_{CC} = 3.3V$, V_{REF} should be 1.25V and $R2/R1 = 0.609$.

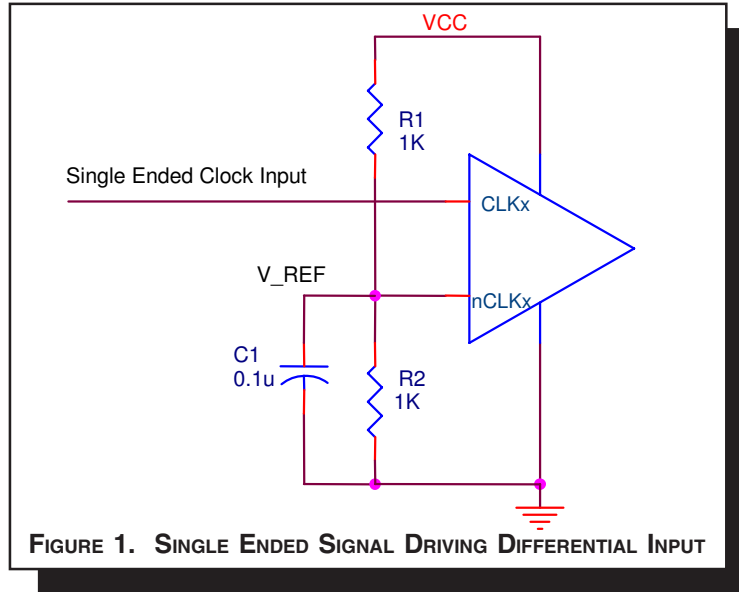

TERMINATION FOR 3.3V LVPECL OUTPUTS

The clock layout topology shown below is a typical termination for LVPECL outputs. The two different layouts mentioned are recommended only as guidelines.

FOUT and nFOUT are low impedance follower outputs that generate ECL/LVPECL compatible outputs. Therefore, terminating resistors (DC current path to ground) or current sources must be used for functionality. These outputs are designed to drive

50Ω transmission lines. Matched impedance techniques should be used to maximize operating frequency and minimize signal distortion. Figures 2A and 2B show two different layouts which are recommended only as guidelines. Other suitable clock layouts may exist and it would be recommended that the board designers simulate to guarantee compatibility across all printed circuit and clock component process variations.

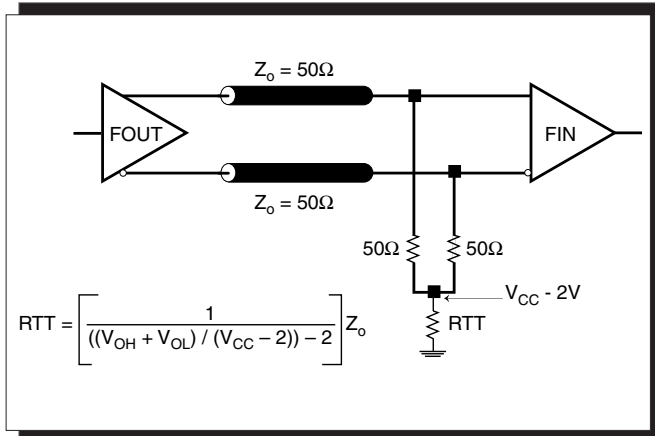

FIGURE 2A. LVPECL OUTPUT TERMINATION

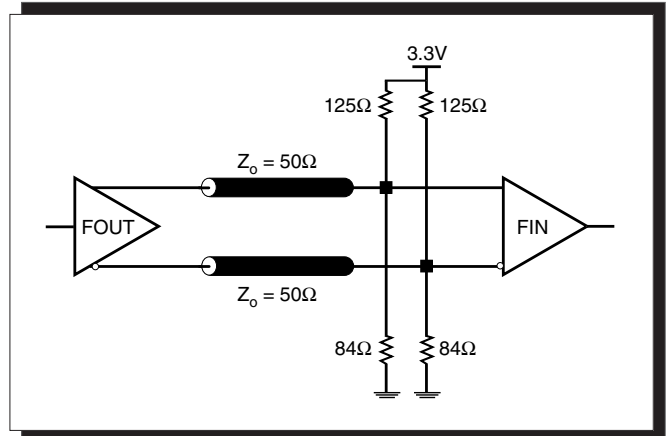

FIGURE 2B. LVPECL OUTPUT TERMINATION

TERMINATION FOR 2.5V LVPECL OUTPUTS

Figure 3A and Figure 3B show examples of termination for 2.5V LVPECL driver. These terminations are equivalent to terminating 50Ω to $V_{CC} - 2V$. For $V_{CC} = 2.5V$, the $V_{CC} - 2V$ is very close to

ground level. The R3 in Figure 3B can be eliminated and the termination is shown in Figure 3C.

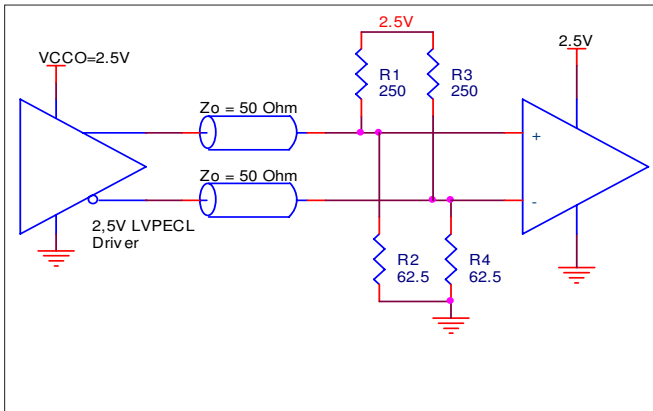

FIGURE 3A. 2.5V LVPECL DRIVER TERMINATION EXAMPLE

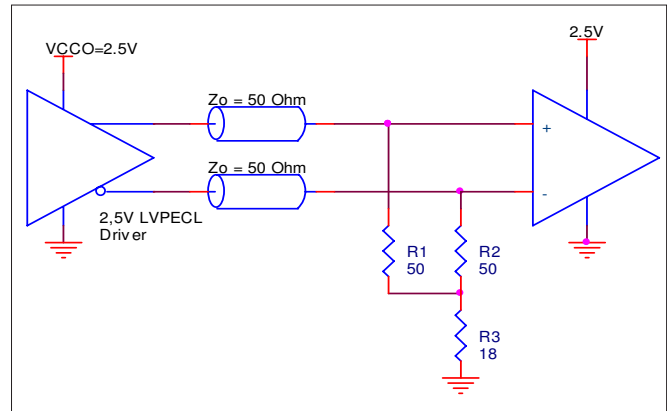

FIGURE 3B. 2.5V LVPECL DRIVER TERMINATION EXAMPLE

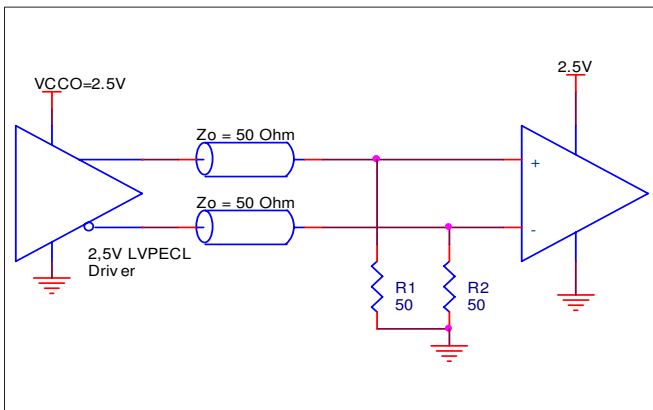

FIGURE 3C. 2.5V LVPECL TERMINATION EXAMPLE

DIFFERENTIAL CLOCK INPUT INTERFACE

The CLK/nCLK accepts LVDS, LVPECL, LVHSTL, SSTL, HCSSL and other differential signals. Both V_{SWING} and V_{OH} must meet the V_{PP} and V_{CMR} input requirements. Figures 4A to 4E show interface examples for the CLK/nCLK input driven by the most common driver types. The input interfaces suggested here are

examples only. Please consult with the vendor of the driver component to confirm the driver termination requirements. For example in *Figure 4A*, the input termination applies for LVHSTL drivers. If you are using an LVHSTL driver from another vendor, use their termination recommendation.

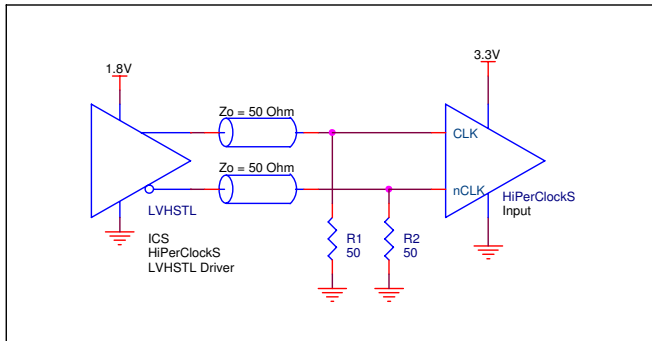

FIGURE 4A. CLK/nCLK INPUT DRIVEN BY LVHSTL DRIVER

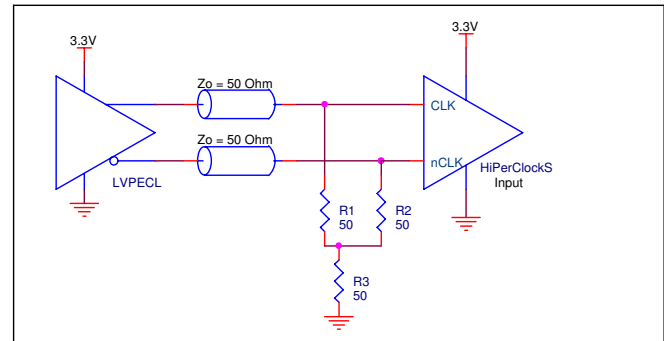

FIGURE 4B. CLK/nCLK INPUT DRIVEN BY 3.3V LVPECL DRIVER

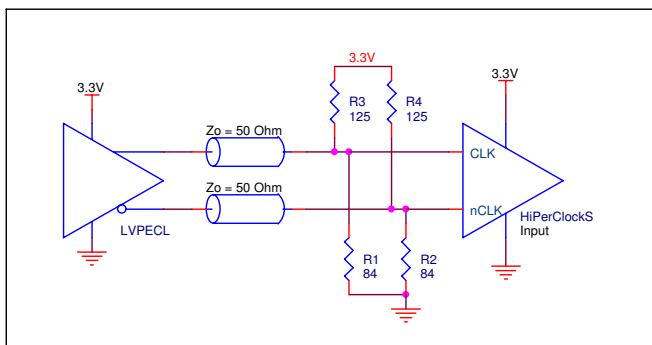

FIGURE 4C. CLK/nCLK INPUT DRIVEN BY 3.3V LVPECL DRIVER

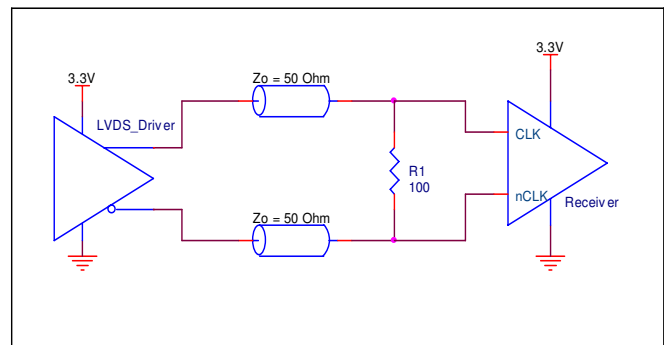

FIGURE 4D. CLK/nCLK INPUT DRIVEN BY 3.3V LVDS DRIVER

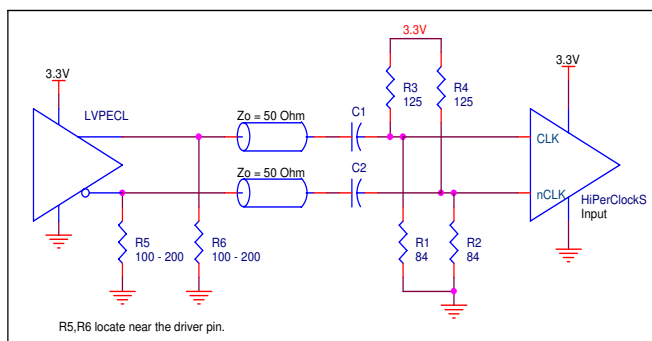

FIGURE 4E. CLK/nCLK INPUT DRIVEN BY 3.3V LVPECL DRIVER WITH AC COUPLE



POWER CONSIDERATIONS

This section provides information on power dissipation and junction temperature for the ICS85310I-21. Equations and example calculations are also provided.

1. Power Dissipation.

The total power dissipation for the ICS85310I-21 is the sum of the core power plus the power dissipated in the load(s). The following is the power dissipation for $V_{CC} = 3.8V$, which gives worst case results.

NOTE: Please refer to Section 3 for details on calculating power dissipated in the load.

- Power (core)_{MAX} = $V_{CC_MAX} * I_{EE_MAX} = 3.8V * 120mA = 456mW$
- Power (outputs)_{MAX} = **30mW/Loaded Output pair**
 If all outputs are loaded, the total power is $10 * 30mW = 300mW$

Total Power_{MAX} (3.8V, with all outputs switching) = $456mW + 300mW = 756mW$

2. Junction Temperature.

Junction temperature, T_j , is the temperature at the junction of the bond wire and bond pad and directly affects the reliability of the device. The maximum recommended junction temperature for the devices is 125°C.

The equation for T_j is as follows: $T_j = \theta_{JA} * Pd_total + T_A$

T_j = Junction Temperature

θ_{JA} = Junction-to-Ambient Thermal Resistance

Pd_total = Total Device Power Dissipation (example calculation is in section 1 above)

T_A = Ambient Temperature

In order to calculate junction temperature, the appropriate junction-to-ambient thermal resistance θ_{JA} must be used. Assuming a moderate air flow of 200 linear feet per minute and a multi-layer board, the appropriate value is 42.1°C/W per Table 6 below.

Therefore, T_j for an ambient temperature of 85°C with all outputs switching is:
 $85°C + 0.756W * 42.1°C/W = 116.8°C$. This is below the limit of 125°C

This calculation is only an example. T_j will obviously vary depending on the number of loaded outputs, supply voltage, air flow, and the type of board (single layer or multi-layer).

TABLE 6. THERMAL RESISTANCE θ_{JA} FOR 32-PIN LQFP, FORCED CONVECTION

θ_{JA} by Velocity (Linear Feet per Minute)			
	0	200	500
Single-Layer PCB, JEDEC Standard Test Boards	67.8°C/W	55.9°C/W	50.1°C/W
Multi-Layer PCB, JEDEC Standard Test Boards	47.9°C/W	42.1°C/W	39.4°C/W

NOTE: Most modern PCB designs use multi-layered boards. The data in the second row pertains to most designs.

3. Calculations and Equations.

LVPECL output driver circuit and termination are shown in Figure 5.

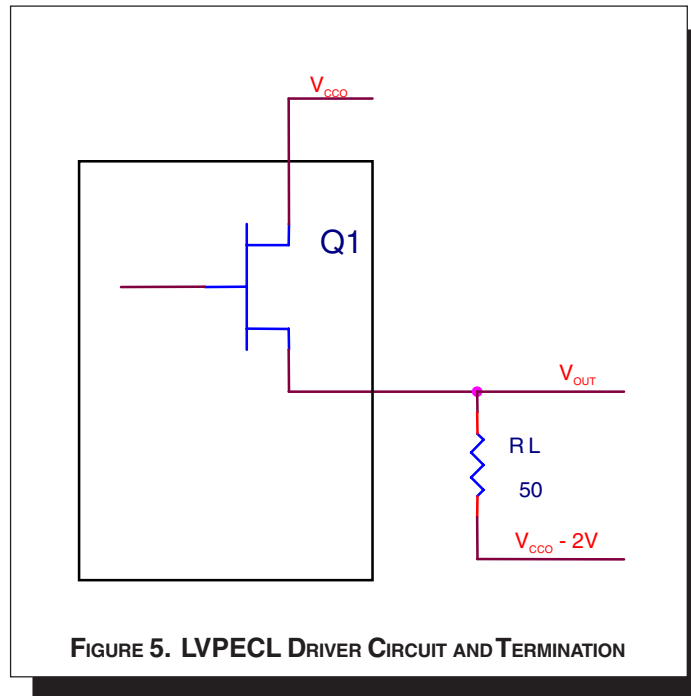

To calculate worst case power dissipation into the load, use the following equations which assume a 50Ω load, and a termination voltage of $V_{CCO} - 2V$.

- For logic high, $V_{OUT} = V_{OH_MAX} = V_{CCO_MAX} - 0.9V$

$$(V_{CCO_MAX} - V_{OH_MAX}) = 0.9V$$

- For logic low, $V_{OUT} = V_{OL_MAX} = V_{CCO_MAX} - 1.7V$

$$(V_{CCO_MAX} - V_{OL_MAX}) = 1.7V$$

$$Pd_H = [(V_{OH_MAX} - (V_{CCO_MAX} - 2V))/R_L] * (V_{CCO_MAX} - V_{OH_MAX}) = [(2V - (V_{CCO_MAX} - V_{OH_MAX}))/R_L] * (V_{CCO_MAX} - V_{OH_MAX}) = [(2V - 0.9V)/50\Omega] * 0.9V = 19.8mW$$

$$Pd_L = [(V_{OL_MAX} - (V_{CCO_MAX} - 2V))/R_L] * (V_{CCO_MAX} - V_{OL_MAX}) = [(2V - (V_{CCO_MAX} - V_{OL_MAX}))/R_L] * (V_{CCO_MAX} - V_{OL_MAX}) = [(2V - 1.7V)/50\Omega] * 1.7V = 10.2mW$$

Total Power Dissipation per output pair = Pd_H + Pd_L = 30mW



RELIABILITY INFORMATION

TABLE 7. θ_{JA} vs. AIR FLOW TABLE FOR 32 LEAD LQFP

	θ_{JA} by Velocity (Linear Feet per Minute)		
	0	200	500
Single-Layer PCB, JEDEC Standard Test Boards	67.8°C/W	55.9°C/W	50.1°C/W
Multi-Layer PCB, JEDEC Standard Test Boards	47.9°C/W	42.1°C/W	39.4°C/W

NOTE: Most modern PCB designs use multi-layered boards. The data in the second row pertains to most designs.

TRANSISTOR COUNT

The transistor count for ICS85310I-21 is: 1216

PACKAGE OUTLINE - Y SUFFIX FOR 32 LEAD LQFP

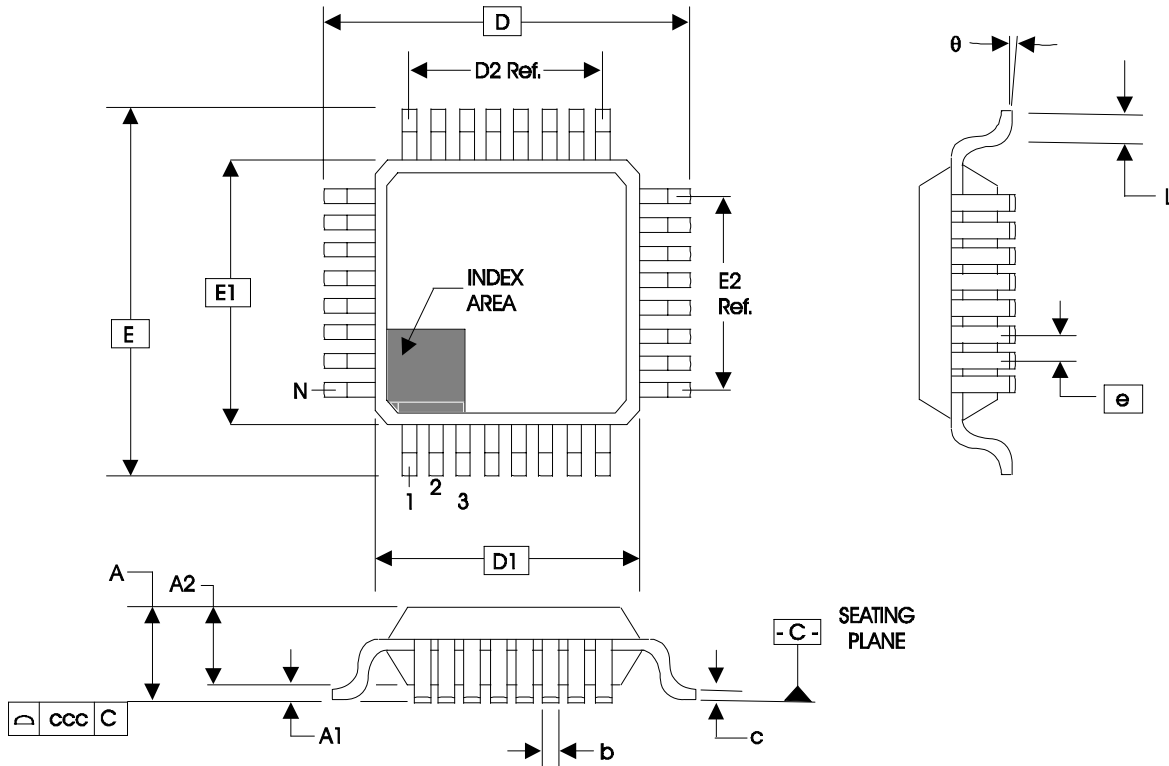

TABLE 8. PACKAGE DIMENSIONS

JEDEC VARIATION ALL DIMENSIONS IN MILLIMETERS			
SYMBOL	BBA		
	MINIMUM	NOMINAL	MAXIMUM
N	32		
A	--	--	1.60
A1	0.05	--	0.15
A2	1.35	1.40	1.45
b	0.30	0.37	0.45
c	0.09	--	0.20
D	9.00 BASIC		
D1	7.00 BASIC		
D2	5.60 Ref.		
E	9.00 BASIC		
E1	7.00 BASIC		
E2	5.60 Ref.		
e	0.80 BASIC		
L	0.45	0.60	0.75
theta	0°	--	7°
ccc	--	--	0.10

Reference Document: JEDEC Publication 95, MS-026



ICS85310I-21

LOW SKEW, DUAL, 1-TO-5
DIFFERENTIAL-TO-2.5V/3.3V ECL/LVPECL FANOUT BUFFER

TABLE 9. ORDERING INFORMATION

Part/Order Number	Marking	Package	Shipping Packaging	Temperature
85310AYI-21	ICS85310AYI21	32 lead LQFP	tray	-40°C to 85°C
85310AYI-21T	ICS85310AYI21	32 lead LQFP	1000 tape & reel	-40°C to 85°C
85310AYI-21LN	ICS85310AI21N	32 lead LQFP, "Lead-Free Annealed"	tray	-40°C to 85°C
85310AYI-21LNT	ICS85310AI21N	32 lead LQFP "Lead-Free Annealed"	1000 tape & reel	-40°C to 85°C

NOTE: Parts that are ordered with an "LN" suffix to the part number are the Pb-Free configuration and are RoHS compliant.

While the information presented herein has been checked for both accuracy and reliability, Integrated Device Technology, Inc. (IDT) assumes no responsibility for either its use or for infringement of any patents or other rights of third parties, which would result from its use. No other circuits, patents, or licenses are implied. This product is intended for use in normal commercial and industrial applications. Any other applications such as those requiring high reliability, or other extraordinary environmental requirements are not recommended without additional processing by IDT. IDT reserves the right to change any circuitry or specifications without notice. IDT does not authorize or warrant any IDT product for use in life support devices or critical medical instruments.



ICS85310I-21
LOW SKEW, DUAL, 1-TO-5
DIFFERENTIAL-TO-2.5V/3.3V ECL/LVPECL FANOUT BUFFER

REVISION HISTORY SHEET				
Rev	Table	Page	Description of Change	Date
A		8	Added Termination for LVPECL Outputs.	5/30/02
A			Updated part number from ICS85310-21 to ICS85310I-21 throughout the data sheet to reflect operating temperature.	7/24/02
A	T9	13	Ordering Information Table - corrected Marking from ICS85310AYI-21 to ICS85310AYI21.	7/25/02
B	T4A	3	Power Supply table - increased max. value for I_{EE} to 120mA from 30mA max.	10/23/02
B		9	Power Considerations have re-adjusted to the increased I_{EE} value.	
C	T2	2	Pin Characteristics table - changed CIN from 4pF max. to 4pF typical.	4/14/04
		3	Updated Absolute Maximum Rating.	
		7	Added Termination for 2.5V LVPECL Outputs.	
		8	Added Differential Clock Input Interface.	
C	T9	1	Added Lead-Free bullet in Features section.	10/8/04
		13	Ordering Information table - corrected "Lead Free" part/order number.	
D	T5	1	Features Section - added Additive Phase Jitter bullet.	6/30/05
		4	AC Characteristics Table - added Additive Phase Jitter row.	
		5	Added Additive Phase Jitter Section.	
E	T9	14	Ordering Information Table - added Lead-Free Note.	4/11/07
		14C	LVPECL DC Characteristics Table -corrected V_{OH} max. from $V_{CCO} - 1.0V$ to $V_{CCO} - 0.9V$; and V_{SWING} max. from 0.85V to 1.0V.	
E	T4C	3	Power Considerations - corrected power dissipation to reflect V_{OH} max in Table 4C.	4/11/07
		10 - 11		
E	T9	14	Updated datasheet's header/footer with IDT from ICS.	8/13/10
		14	Removed ICS prefix from Part/Order Number column.	
		16	Added Contact Page.	



ICS85310I-21
LOW SKEW, DUAL, 1-TO-5
DIFFERENTIAL-TO-2.5V/3.3V ECL/LVPECL FANOUT BUFFER

We've Got Your Timing Solution.



6024 Silver Creek Valley Road
San Jose, CA 95138

Sales
800-345-7015 (inside USA)
+408-284-8200 (outside USA)
Fax: 408-284-2775

Tech Support
netcom@idt.com

© 2010 Integrated Device Technology, Inc. All rights reserved. Product specifications subject to change without notice. IDT, the IDT logo, ICS and HiPerClocks are trademarks of Integrated Device Technology, Inc. Accelerated Thinking is a service mark of Integrated Device Technology, Inc. All other brands, product names and marks are or may be trademarks or registered trademarks used to identify products or services of their respective owners.
Printed in USA