



ICS83023I

DUAL, 1-TO-1

DIFFERENTIAL-TO-LVCMOS TRANSLATOR/BUFFER

GENERAL DESCRIPTION

The ICS83023I is a dual, 1-to-1 Differential-to-LVCMOS Translator/Fanout Buffer. The differential inputs can accept most differential signal types (LVDS, LVHSTL, LVPECL, SSTL, and HCSL) and translate into two single-ended LVCMOS outputs. The small 8-lead SOIC footprint makes this device ideal for use in applications with limited board space.

Features

- Two LVCMOS / LVTTTL outputs
- Two differential CLKx, nCLKx input pairs
- CLK, nCLK pairs can accept the following differential input levels: LVDS, LVPECL, LVHSTL, SSTL, HCSL
- Maximum output frequency: 350MHz (typical)
- Output skew: 60ps (maximum)
- Part-to-part skew: 500ps (maximum)
- Additive phase jitter, RMS: 0.14ps (typical)
- Small 8 lead SOIC package saves board space
- 3.3V operating supply
- -40°C to 85°C ambient operating temperature
- Available in both standard and lead-free RoHS-compliant packages

BLOCK DIAGRAM

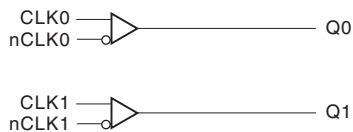

PIN ASSIGNMENT

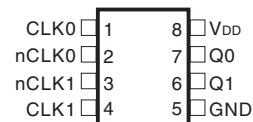

ICS83023I

8-Lead SOIC

3.8mm x 4.8mm x 1.47mm package body

M Package

Top View

**TABLE 1. PIN DESCRIPTIONS**

Number	Name	Type		Description
1	CLK0	Input	Pulldown	Non-inverting differential clock input.
2	nCLK0	Input	Pullup	Inverting differential clock input.
3	nCLK1	Input	Pullup	Inverting differential clock input.
4	CLK1	Input	Pulldown	Non-inverting differential clock input.
5	GND	Power		Power supply ground.
6	Q1	Output		Single clock output. LVCMOS / LVTTTL interface levels.
7	Q0	Output		Single clock output. LVCMOS / LVTTTL interface levels.
8	V _{DD}	Power		Positive supply pin.

NOTE: *Pullup* and *Pulldown* refer to internal input resistors. See Table 2, Pin Characteristics, for typical values.

TABLE 2. PIN CHARACTERISTICS

Symbol	Parameter	Test Conditions	Minimum	Typical	Maximum	Units
C _{IN}	Input Capacitance			4		pF
C _{PD}	Power Dissipation Capacitance (per output)	V _{DD} = 3.6V		23		pF
R _{PULLUP}	Input Pullup Resistor			51		kΩ
R _{PULLDOWN}	Input Pulldown Resistor			51		kΩ
R _{OUT}	Output Impedance			7		Ω



ABSOLUTE MAXIMUM RATINGS

Supply Voltage, V_{DD}	4.6V
Inputs, V_i	-0.5V to $V_{DD} + 0.5V$
Outputs, V_o	-0.5V to $V_{DD} + 0.5V$
Package Thermal Impedance, θ_{JA}	112.7°C/W (0 lfpm)
Storage Temperature, T_{STG}	-65°C to 150°C

NOTE: Stresses beyond those listed under Absolute Maximum Ratings may cause permanent damage to the device. These ratings are stress specifications only. Functional operation of product at these conditions or any conditions beyond those listed in the *DC Characteristics* or *AC Characteristics* is not implied. Exposure to absolute maximum rating conditions for extended periods may affect product reliability.

TABLE 3A. POWER SUPPLY DC CHARACTERISTICS, $V_{DD} = 3.3V \pm 0.3V$, $T_A = -40^\circ C$ TO $85^\circ C$

Symbol	Parameter	Test Conditions	Minimum	Typical	Maximum	Units
V_{DD}	Positive Supply Voltage		3.0	3.3	3.6	V
I_{DD}	Positive Supply Current				20	mA

TABLE 3B. LVCMOS / LVTTTL DC CHARACTERISTICS, $V_{DD} = 3.3V \pm 0.3V$, $T_A = -40^\circ C$ TO $85^\circ C$

Symbol	Parameter	Test Conditions	Minimum	Typical	Maximum	Units
V_{OH}	Output High Voltage; NOTE 1		2.6			V
V_{OL}	Output Low Voltage; NOTE 1				0.5	V

NOTE 1: Outputs terminated with 50Ω to $V_{DD}/2$. See Parameter Measurement Section, 3.3V Output Load Test Circuit.

TABLE 3C. DIFFERENTIAL DC CHARACTERISTICS, $V_{DD} = 3.3V \pm 0.3V$, $T_A = -40^\circ C$ TO $85^\circ C$

Symbol	Parameter	Test Conditions	Minimum	Typical	Maximum	Units	
I_{IH}	Input High Current	nCLK0, nCLK1	$V_{IN} = V_{DD} = 3.6V$			5	μA
		CLK0, CLK1	$V_{IN} = V_{DD} = 3.6V$			150	μA
I_{IL}	Input Low Current	nCLK0, nCLK1	$V_{IN} = 0V, V_{DD} = 3.6V$	-150			μA
		CLK0, CLK1	$V_{IN} = 0V, V_{DD} = 3.6V$	-5			μA
V_{PP}	Peak-to-Peak Input Voltage		0.15		1.3	V	
V_{CMR}	Common Mode Input Voltage; NOTE 1, 2		GND + 0.5		$V_{DD} - 0.85$	V	

NOTE 1: For single-ended applications, the maximum input voltage for CLKx, nCLKx is $V_{DD} + 0.3V$.

NOTE 2: Common mode voltage is defined as V_{IH} .

**TABLE 4. AC CHARACTERISTICS, $V_{DD} = 3.3V \pm 0.3V$, $T_A = -40^\circ C$ TO $85^\circ C$**

Symbol	Parameter	Test Conditions	Minimum	Typical	Maximum	Units
f_{MAX}	Maximum Output Frequency			350		MHz
t_{PD}	Propagation Delay; NOTE 1		1.8	2.1	2.4	ns
$t_{sk(o)}$	Output Skew; NOTE 2, 4				60	ps
$t_{sk(pp)}$	Part-to-Part Skew; NOTE 3, 4				500	ps
t_{jit}	Buffer Additive Phase Jitter, RMS; refer to Additive Phase Jitter Section	100MHz, Integration Range (637kHz-10MHz)		0.14		ps
t_R	Output Rise Time	0.8V to 2V	100	250	400	ps
t_F	Output Fall Time	0.8V to 2V	100	250	400	ps
odc	Output Duty Cycle	$f \leq 166MHz$	45	50	55	%
		$f > 166MHz$	43	50	57	%

All parameters measured at f_{MAX} unless noted otherwise. See Parameter Measurement Information.

NOTE 1: Measured from the differential input crossing point to $V_{DD}/2$ of the output.

NOTE 2: Defined as skew between outputs at the same supply voltage and with equal load conditions. Measured at $V_{DD}/2$. Input clocks are phase aligned.

NOTE 3: Defined as skew between outputs on different devices operating at the same supply voltages and with equal load conditions. Using the same type of inputs on each device, the outputs are measured at $V_{DD}/2$.

NOTE 4: This parameter is defined in accordance with JEDEC Standard 65.



ADDITIVE PHASE JITTER

The spectral purity in a band at a specific offset from the fundamental compared to the power of the fundamental is called the **dBc Phase Noise**. This value is normally expressed using a Phase noise plot and is most often the specified plot in many applications. Phase noise is defined as the ratio of the noise power present in a 1Hz band at a specified offset from the fundamental frequency to the power value of the fundamental. This ratio is expressed in decibels (dBm) or a

ratio of the power in the 1Hz band to the power in the fundamental. When the required offset is specified, the phase noise is called a **dBc** value, which simply means dBm at a specified offset from the fundamental. By investigating jitter in the frequency domain, we get a better understanding of its effects on the desired application over the entire time record of the signal. It is mathematically possible to calculate an expected bit error rate given a phase noise plot.

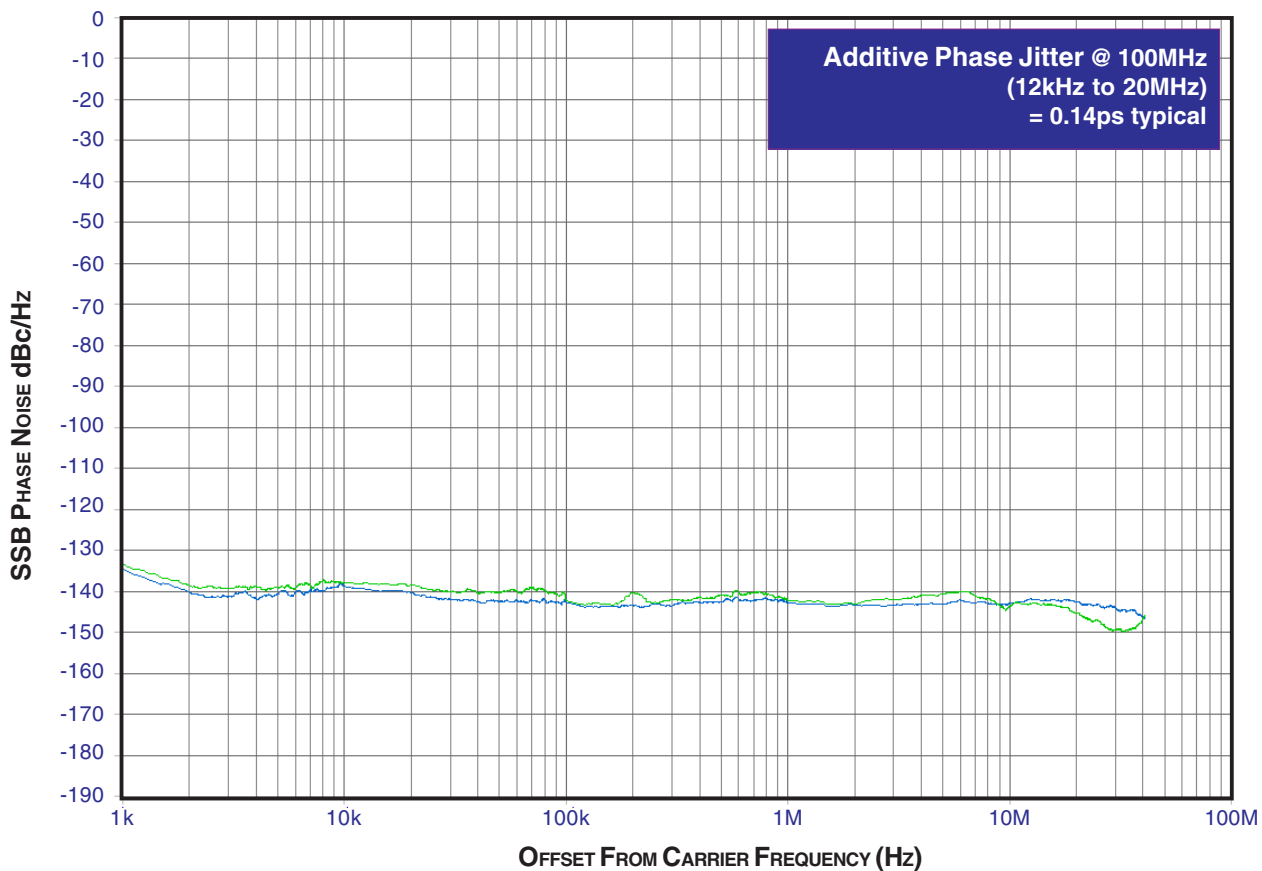

As with most timing specifications, phase noise measurements have issues. The primary issue relates to the limitations of the equipment. Often the noise floor of the equipment is higher than the noise floor of the device. This is illustrated

above. The device meets the noise floor of what is shown, but can actually be lower. The phase noise is dependant on the input source and measurement equipment.

PARAMETER MEASUREMENT INFORMATION

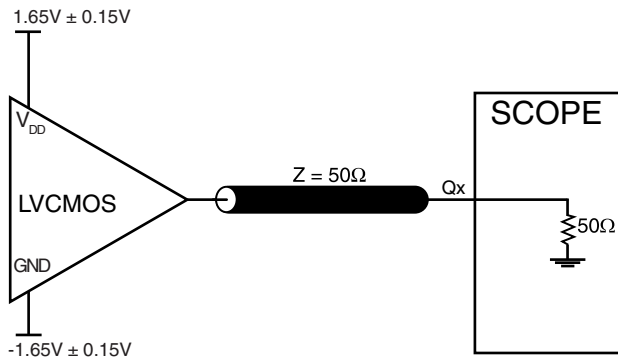
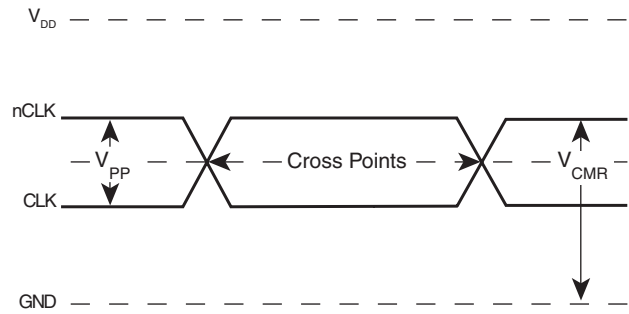
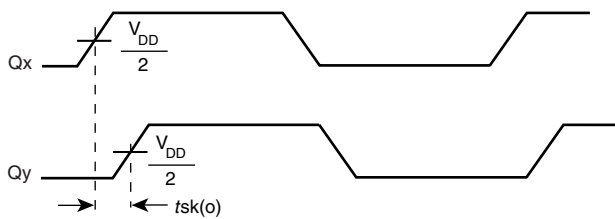
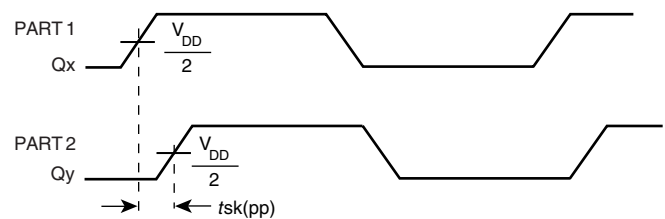
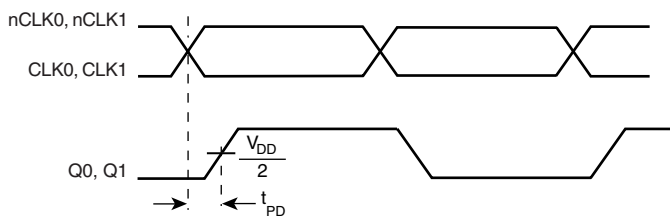
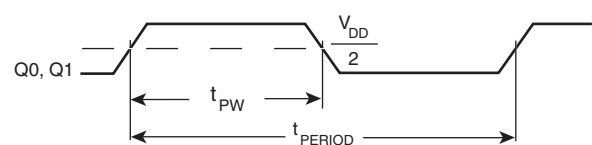
3.3V OUTPUT LOAD AC TEST CIRCUIT

DIFFERENTIAL INPUT LEVEL

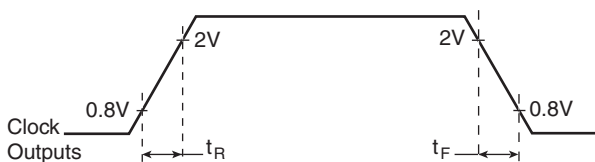
OUTPUT SKEW

PART-TO-PART SKEW

PROPAGATION DELAY

$$odc = \frac{t_{PW}}{t_{PERIOD}} \times 100\%$$

OUTPUT DUTY CYCLE/PULSE WIDTH/PERIOD

OUTPUT RISE/FALL TIME

APPLICATION INFORMATION

WIRING THE DIFFERENTIAL INPUT TO ACCEPT SINGLE ENDED LEVELS

Figure 1 shows how the differential input can be wired to accept single ended levels. The reference voltage $V_{REF} = V_{DD}/2$ is generated by the bias resistors R1, R2 and C1. This bias circuit should be located as close as possible to the input pin. The

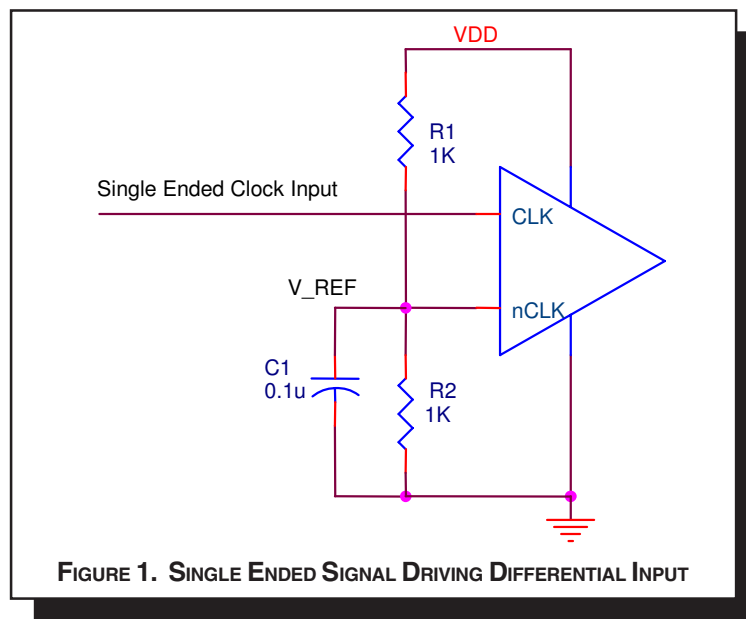
ratio of R1 and R2 might need to be adjusted to position the V_{REF} in the center of the input voltage swing. For example, if the input clock swing is only 2.5V and $V_{DD} = 3.3V$, V_{REF} should be 1.25V and $R2/R1 = 0.609$.



RECOMMENDATIONS FOR UNUSED INPUT AND OUTPUT PINS

INPUTS:

CLK/nCLK INPUT:

For applications not requiring the use of the differential input, both CLK and nCLK can be left floating. Though not required, but for additional protection, a 1k Ω resistor can be tied from CLK to ground.

OUTPUTS:

LVCMOS OUTPUT:

All unused LVCMOS output can be left floating. We recommend that there is no trace attached.

DIFFERENTIAL CLOCK INPUT INTERFACE

The CLK /nCLK accepts LVDS, LVPECL, LVHSTL, SSTL, HCSL and other differential signals. Both V_{SWING} and V_{OH} must meet the V_{PP} and V_{CMR} input requirements. Figures 2A to 2E show interface examples for the CLK/nCLK input driven by the most common driver types. The input interfaces suggested

here are examples only. Please consult with the vendor of the driver component to confirm the driver termination requirements. For example in *Figure 2A*, the input termination applies for LVHSTL drivers. If you are using an LVHSTL driver from another vendor, use their termination recommendation.

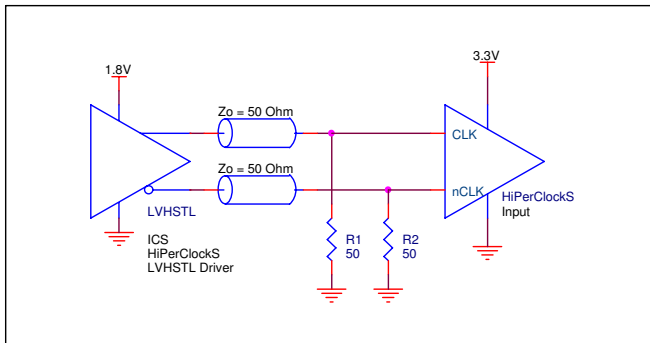
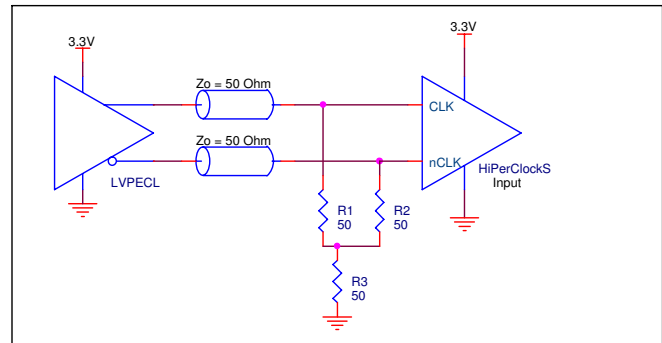
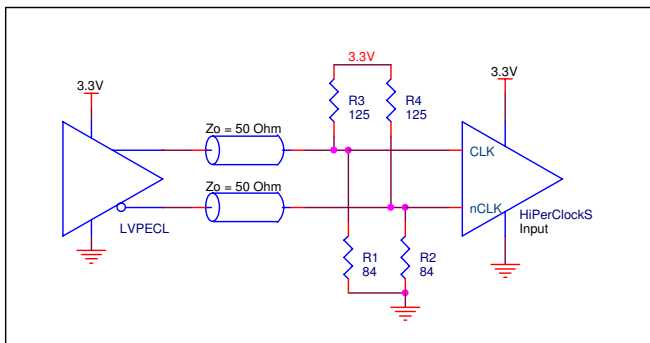
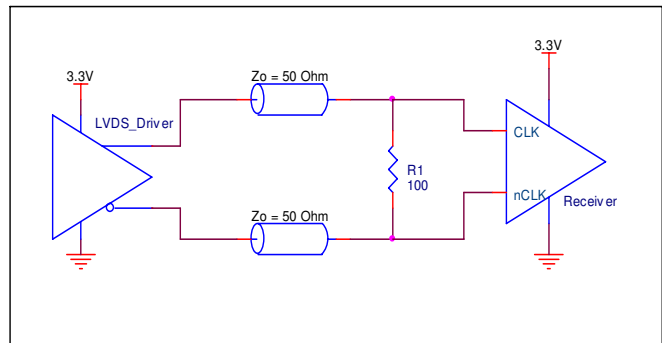
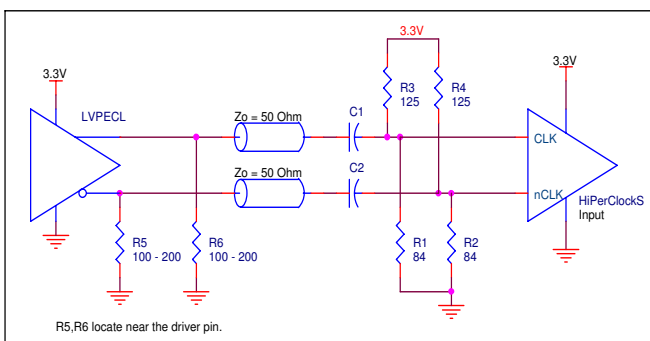
FIGURE 2A. CLK/nCLK INPUT DRIVEN BY LVHSTL DRIVER

FIGURE 2B. CLK/nCLK INPUT DRIVEN BY 3.3V LVPECL DRIVER

FIGURE 2C. CLK/nCLK INPUT DRIVEN BY 3.3V LVPECL DRIVER

FIGURE 2D. CLK/nCLK INPUT DRIVEN BY 3.3V LVDS DRIVER

FIGURE 2E. CLK/nCLK INPUT DRIVEN BY 3.3V LVPECL DRIVER WITH AC COUPLE



RELIABILITY INFORMATION

TABLE 5. θ_{JA} VS. AIR FLOW TABLE FOR 8 LEAD SOIC

θ_{JA} by Velocity (Linear Feet per Minute)			
	0	200	500
Single-Layer PCB, JEDEC Standard Test Boards	153.3°C/W	128.5°C/W	115.5°C/W
Multi-Layer PCB, JEDEC Standard Test Boards	112.7°C/W	103.3°C/W	97.1°C/W

NOTE: Most modern PCB designs use multi-layered boards. The data in the second row pertains to most designs.

TRANSISTOR COUNT

The transistor count for ICS83023I is: 416

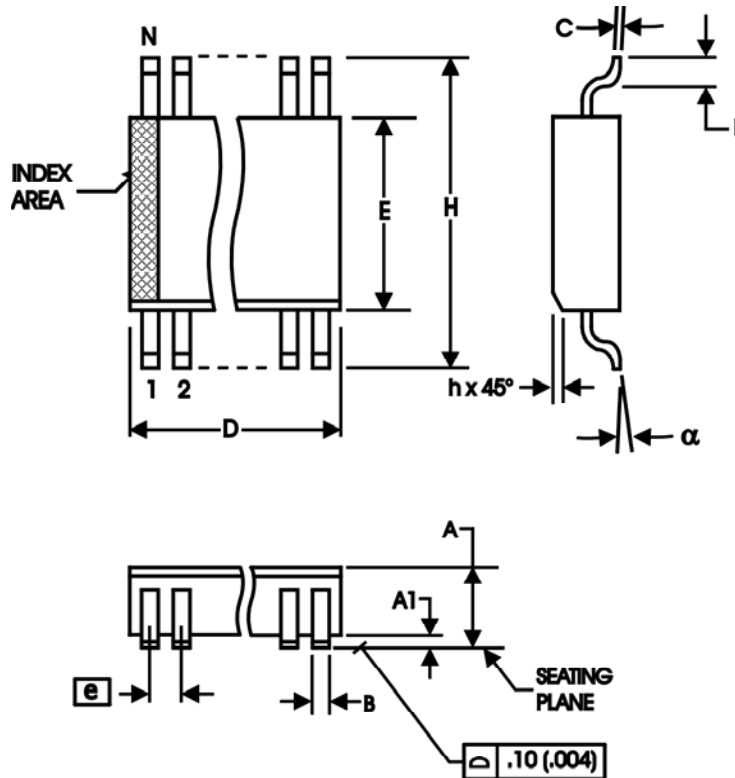
PACKAGE OUTLINE - SUFFIX M FOR 8 LEAD SOIC

TABLE 6. PACKAGE DIMENSIONS

SYMBOL	Millimeters	
	MINIMUM	MAXIMUM
N	8	
A	1.35	1.75
A1	0.10	0.25
B	0.33	0.51
C	0.19	0.25
D	4.80	5.00
E	3.80	4.00
e	1.27 BASIC	
H	5.80	6.20
h	0.25	0.50
L	0.40	1.27
α	0°	8°

Reference Document: JEDEC Publication 95, MS-012

**ICS83023I**

DUAL, 1-TO-1

DIFFERENTIAL-TO-LVCMOS TRANSLATOR/BUFFER

TABLE 7. ORDERING INFORMATION

Part/Order Number	Marking	Package	Shipping Packaging	Temperature
83023AMI	83021AMI	8 lead SOIC	tube	-40°C to 85°C
83023AMIT	83021AMI	8 lead SOIC	2500 tape & reel	-40°C to 85°C
83023AMILF	83023AIL	8 lead "Lead-Free" SOIC	tube	-40°C to 85°C
83023AMILFT	83023AIL	8 lead "Lead-Free" SOIC	2500 tape & reel	-40°C to 85°C

NOTE: Parts that are ordered with an "LF" suffix to the part number are the Pb-Free configuration and are RoHS compliant.

While the information presented herein has been checked for both accuracy and reliability, Integrated Device Technology, Inc. (IDT) assumes no responsibility for either its use or for infringement of any patents or other rights of third parties, which would result from its use. No other circuits, patents, or licenses are implied. This product is intended for use in normal commercial and industrial applications. Any other applications such as those requiring high reliability, or other extraordinary environmental requirements are not recommended without additional processing by IDT. IDT reserves the right to change any circuitry or specifications without notice. IDT does not authorize or warrant any IDT product for use in life support devices or critical medical instruments.

**ICS83023I**

DUAL, 1-TO-1

DIFFERENTIAL-TO-LVCMOS TRANSLATOR/BUFFER

REVISION HISTORY SHEET				
Rev	Table	Page	Description of Change	Date
A	7	11	Ordering Information Table - corrected Part/Order Number for Tape & Reel to read ICS83023AMIT from ICS83023AMI.	09/09/02
B	T2 T4	1	Features Section - added Additive Phase Jitter and Lead-Free bullets.	12/12/05
		2	Pin Characteristics Table - changed C_{IN} from 4pF max. to 4pF typical.	
	4	AC Characteristics Table - added Additive Phase Jitter row.		
	5	Added Additive Phase Jitter Plot.		
	7	Added <i>Recommendations for Unused Input and Output Pins</i> .		
T7	8	Added <i>Differential Clock Input Interface</i> .		
	11	Ordering Information Table - added Lead-Free Part Number and Note. Update datasheet format.		
B	T7	11	Ordering information Table - added Lead-Free marking.	1/18/08
B	T7	11	Updated datasheet's header/footer with IDT from ICS.	7/29/10
		13	Removed ICS prefix from Part/Order Number column. Added Contact Page.	



ICS83023I
DUAL, 1-TO-1
DIFFERENTIAL-TO-LVCMOS TRANSLATOR/BUFFER

We've Got Your Timing Solution.



6024 Silver Creek Valley Road
San Jose, CA 95138

Sales
800-345-7015 (inside USA)
+408-284-8200 (outside USA)
Fax: 408-284-2775

Tech Support
netcom@idt.com

© 2010 Integrated Device Technology, Inc. All rights reserved. Product specifications subject to change without notice. IDT, the IDT logo, ICS and HiPerClockS are trademarks of Integrated Device Technology, Inc. Accelerated Thinking is a service mark of Integrated Device Technology, Inc. All other brands, product names and marks are or may be trademarks or registered trademarks used to identify products or services of their respective owners.
Printed in USA