



## 3.3V CMOS 1-TO-4 CLOCK DRIVER

**IDT74FCT38074**

### FEATURES:

- Advanced CMOS Technology
- Guaranteed low skew < 100ps (max.)
- Very low duty cycle distortion < 250ps (max.)
- High speed propagation delay < 3ns (max.)
- Very low CMOS power levels
- TTL compatible inputs and outputs
- 1:4 fanout
- Maximum output rise and fall time < 1.5ns (max.)
- Low input capacitance: 3pF typical
- $V_{CC} = 3.3V \pm 0.3V$
- Inputs can be driven from 3.3V or 5V components
- Operating frequency up to 166MHz
- Available in SOIC package

### DESCRIPTION:

The FCT38074 is a 3.3V clock driver built using advanced CMOS technology. This low skew clock driver offers 1:4 fanout. The large fanout from a single input reduces loading on the preceding driver and provides an efficient clock distribution network. Multiple power and grounds reduce noise. Typical applications are clock and signal distribution.

### FUNCTIONAL BLOCK DIAGRAM

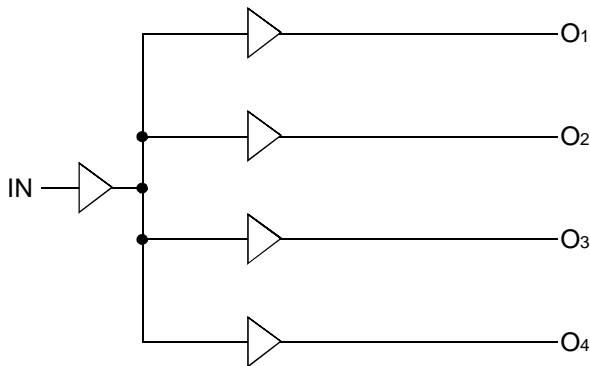

### PIN CONFIGURATION

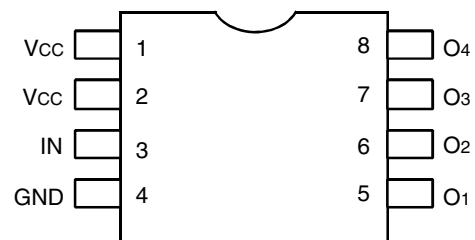

SOIC  
TOP VIEW

### ABSOLUTE MAXIMUM RATINGS(1)

Symbol	Description	Max	Unit
V <sub>CC</sub>	Input Power Supply Voltage	-0.5 to +4.6	V
V <sub>I</sub>	Input Voltage	-0.5 to +5.5	V
V <sub>O</sub>	Output Voltage	-0.5 to V <sub>CC</sub> +0.5	V
T <sub>J</sub>	Junction Temperature	150	°C
T <sub>STG</sub>	Storage Temperature	-65 to +165	°C

**NOTE:**

- Stresses greater than those listed under ABSOLUTE MAXIMUM RATINGS may cause permanent damage to the device. This is a stress rating only and functional operation of the device at these or any other conditions above those indicated in the operational sections of this specification is not implied. Exposure to absolute maximum rating conditions for extended periods may affect reliability.

### CAPACITANCE (T<sub>A</sub> = +25°C, f = 1.0MHz)

Symbol	Parameter <sup>(1)</sup>	Conditions	Typ.	Max.	Unit
C <sub>IN</sub>	Input Capacitance	V <sub>IN</sub> = 0V	3	4	pF
C <sub>OUT</sub>	Output Capacitance	V <sub>OUT</sub> = 0V	—	6	pF

**NOTE:**

- This parameter is measured at characterization but not tested.

### PIN DESCRIPTION

Pin Names	Description
I <sub>N</sub>	Input
O <sub>x</sub>	Outputs

### POWER SUPPLY CHARACTERISTICS

Symbol	Parameter	Test Conditions <sup>(1)</sup>		Min.	Typ. <sup>(2)</sup>	Max.	Unit
I <sub>CCQ</sub>	Quiescent Power Supply Current	V <sub>CC</sub> = Max.	V <sub>IN</sub> = GND or V <sub>CC</sub>	—	0.1	30	μA
ΔI <sub>CC</sub>	Power Supply Current per Input HIGH	V <sub>CC</sub> = Max.	V <sub>IN</sub> = V <sub>CC</sub> - 0.6V	—	45	300	μA
I <sub>CCD</sub>	Dynamic Power Supply Current per Output <sup>(3)</sup>	V <sub>CC</sub> = Max. C <sub>L</sub> = 15pF All Outputs Toggling	V <sub>IN</sub> = V <sub>CC</sub> V <sub>IN</sub> = GND	—	80	120	μA/MHz
I <sub>C</sub>	Total Power Supply Current <sup>(4)</sup>	V <sub>CC</sub> = Max. C <sub>L</sub> = 15pF All Outputs Toggling f <sub>i</sub> = 133MHz	V <sub>IN</sub> = V <sub>CC</sub> V <sub>IN</sub> = GND		80	110	mA
			V <sub>IN</sub> = V <sub>CC</sub> - 0.6V V <sub>IN</sub> = GND		80	110	
		V <sub>CC</sub> = Max. C <sub>L</sub> = 15pF All Outputs Toggling f <sub>i</sub> = 166MHz	V <sub>IN</sub> = V <sub>CC</sub> V <sub>IN</sub> = GND	—	110	140	
			V <sub>IN</sub> = V <sub>CC</sub> - 0.6V V <sub>IN</sub> = GND	—	110	140	

**NOTES:**

- For conditions shown as Max. or Min., use appropriate value specified under Electrical Characteristics for the applicable device type.
- Typical values are at V<sub>CC</sub> = 3.3V, +25°C ambient.
- This parameter is not directly testable, but is derived for use in Total Power Supply calculations.
- I<sub>C</sub> = I<sub>QUIESCENT</sub> + I<sub>INPUTS</sub> + I<sub>DYNAMIC</sub>  
 $I_C = I_{CC} + \Delta I_{CC} \cdot D_H \cdot N_T + I_{CCD} \cdot f_i$   
 I<sub>CC</sub> = Quiescent Current  
 ΔI<sub>CC</sub> = Power Supply Current for a TTL High Input (V<sub>IN</sub> = V<sub>CC</sub> - 0.6V)  
 D<sub>H</sub> = Duty Cycle for TTL Inputs High  
 N<sub>T</sub> = Number of TTL Inputs at D<sub>H</sub>  
 I<sub>CCD</sub> = Dynamic Current Caused by an Input Transition Pair (HLH or LHL)  
 f<sub>i</sub> = Input Frequency

## DC ELECTRICAL CHARACTERISTICS OVER OPERATING RANGE

Following Conditions Apply Unless Otherwise Specified

Industrial:  $T_A = -40^{\circ}\text{C}$  to  $+85^{\circ}\text{C}$ ,  $V_{CC} = 3.3\text{V} \pm 0.3\text{V}$

Symbol	Parameter	Test Conditions <sup>(1)</sup>		Min.	Typ. <sup>(2)</sup>	Max.	Unit
$V_{IH}$	Input HIGH Level			2	—	5.5	V
$V_{IL}$	Input LOW Level			-0.5	—	0.8	V
$I_{IH}$	Input HIGH Current	$V_{CC} = \text{Max.}$	$V_i = 5.5\text{V}$	—	—	$\pm 1$	$\mu\text{A}$
$I_{IL}$	Input LOW Current	$V_{CC} = \text{Max.}$	$V_i = \text{GND}$	—	—	$\pm 1$	
$V_{IK}$	Clamp Diode Voltage	$V_{CC} = \text{Min.}, I_{IN} = -18\text{mA}$		—	-0.7	-1.2	V
$I_{ODH}$	Output HIGH Current	$V_{CC} = 3.3\text{V}, V_{IN} = V_{IH}$ or $V_{IL}, V_O = 1.5\text{V}^{(3,4)}$		-45	-75	-180	mA
$I_{ODL}$	Output LOW Current	$V_{CC} = 3.3\text{V}, V_{IN} = V_{IH}$ or $V_{IL}, V_O = 1.5\text{V}^{(3,4)}$		50	92	200	mA
$I_{OS}$	Short Circuit Current	$V_{CC} = \text{Max.}, V_O = \text{GND}^{(3,4)}$		-60	-135	-240	mA
$V_{OH}$	Output HIGH Voltage	$V_{CC} = \text{Min.}$	$I_{OH} = -12\text{mA}$	2.4 <sup>(5)</sup>	3	—	V
		$V_{IN} = V_{IH}$ or $V_{IL}$	$I_{OH} = -100\mu\text{A}$	$V_{CC} - 0.2$	—	—	
$V_{OL}$	Output LOW Voltage	$V_{CC} = \text{Min.}$	$I_{OL} = 12\text{mA}$	—	0.3	0.5	V
		$V_{IN} = V_{IH}$ or $V_{IL}$	$I_{OL} = 100\mu\text{A}$	—	—	0.2	

### NOTES:

- For conditions shown as Max. or Min., use appropriate value specified under Electrical Characteristics for the applicable device type.
- Typical values are at  $V_{CC} = 3.3, 25^{\circ}\text{C}$  ambient.
- This parameter is guaranteed but not tested.
- Not more than one output should be shorted at one time. Duration of the test should not exceed one second.
- $V_{OH} = V_{CC} - 0.6\text{V}$  at rated current.

## SWITCHING CHARACTERISTICS OVER OPERATING RANGE (3,4)

Symbol	Parameter	Conditions <sup>(1,8)</sup>	Min. <sup>(2)</sup>	Max.	Unit
$t_{PLH}$ $t_{PHL}$	Propagation Delay	$C_L = 15\text{pF}$ $f \leq 166\text{MHz}$	0.5	3	ns
$t_R$	Output Rise Time (0.8V to 2V)		—	1.5	ns
$t_F$	Output Fall Time (2V to 0.8V)		—	1.5	ns
$t_{SK(O)}$	Same device output pin-to-pin skew <sup>(5)</sup>		—	100	ps
$t_{SK(P)}$	Pulse skew <sup>(6)</sup>		—	250	ps
$t_{SK(PP)}$	Part to part skew <sup>(7)</sup>		—	550	ps
$f_{MAX}$	Input Frequency		—	166	MHz

### NOTES:

- See test circuits and waveforms.
- Minimum limits are guaranteed but not tested on Propagation Delays.
- $t_{PLH}$ ,  $t_{PHL}$ ,  $t_{SK(P)}$ , and  $t_{SK(O)}$  are production tested. All other parameters guaranteed but not production tested.
- Propagation delay range indicated by Min. and Max. limit is due to  $V_{CC}$ , operating temperature and process parameters. These propagation delay limits do not imply skew.
- Skew measured between all outputs under identical transitions and load conditions.
- Skew measured is difference between propagation delay times  $t_{PHL}$  and  $t_{PLH}$  of same output under identical load conditions.
- Part to part skew for all outputs given identical transitions and load conditions at identical  $V_{CC}$  levels and temperature.
- Airflow of 1m/s is recommended for frequencies above 133MHz.

## TEST CIRCUITS

### TEST CONDITIONS

Symbol	V <sub>CC</sub> = 3.3V ±0.3V	Unit
C <sub>L</sub>	15	pF
R <sub>L</sub>	33	Ω
R <sub>T</sub>	Z <sub>OUT</sub> of pulse generator	Ω
t <sub>R</sub> / t <sub>F</sub>	1 (0V to 3V or 3V to 0V)	ns

#### DEFINITIONS:

C<sub>L</sub> = Load capacitance: includes jig and probe capacitance.  
 R<sub>T</sub> = Termination resistance: should be equal to Z<sub>OUT</sub> of the Pulse Generator.  
 t<sub>R</sub> / t<sub>F</sub> = Rise/Fall time of the input stimulus from the Pulse Generator.

### TEST WAVEFORMS

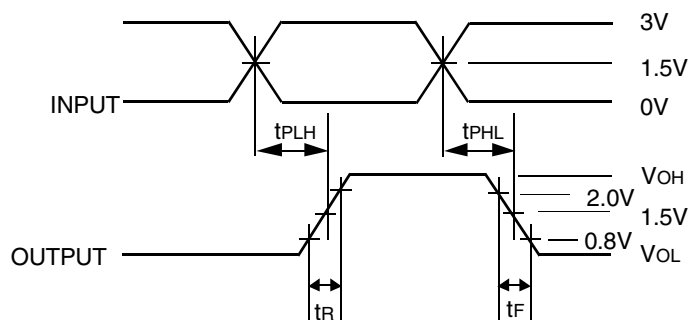

**Propagation Delay**

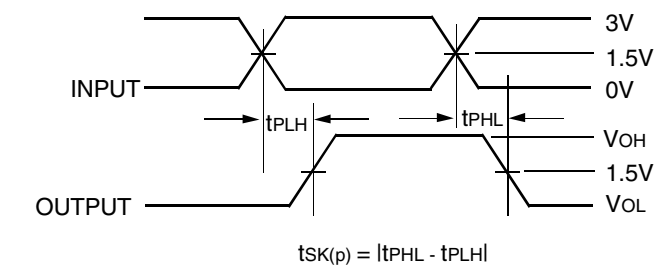

**Pulse Skew - tSK(P)**

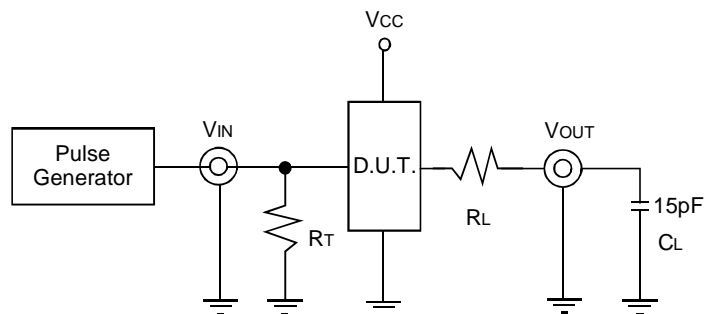

**CL = 15pF Circuit**

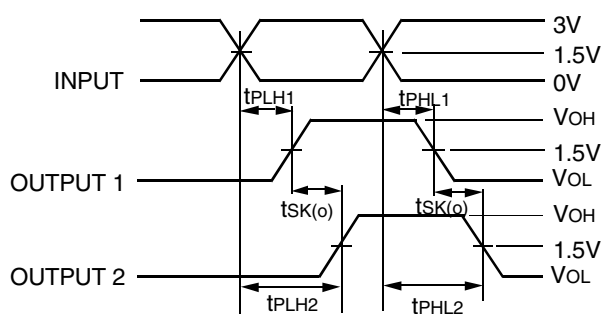

$$t_{SK(O)} = |t_{PLH2} - t_{PLH1}| \text{ or } |t_{PHL2} - t_{PHL1}|$$

**Output Skew - tSK(O)**

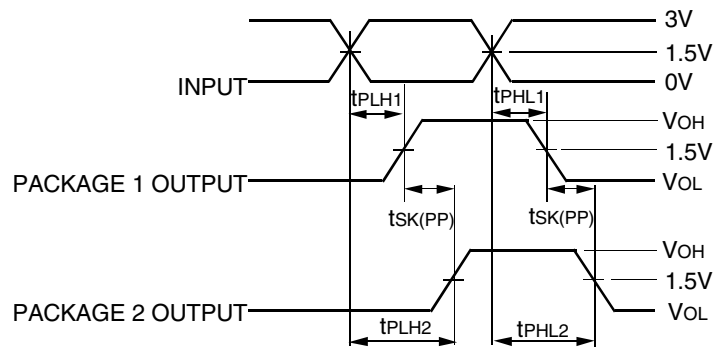

$$t_{SK(PP)} = |t_{PLH2} - t_{PLH1}| \text{ or } |t_{PHL2} - t_{PHL1}|$$

**Part-to-Part Skew - tSK(PP)**

Part-to-Part Skew is for the same package and speed grade.

## ORDERING INFORMATION

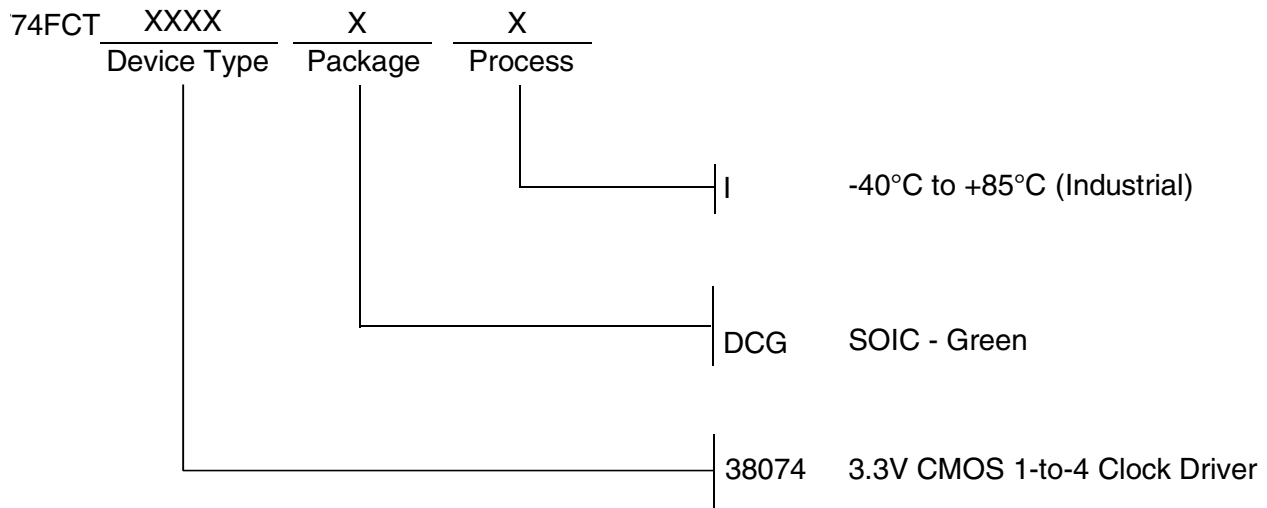

**CORPORATE HEADQUARTERS**  
6024 Silver Creek Valley Road  
San Jose, CA 95138

**for SALES:**  
800-345-7015 or 408-284-8200  
fax: 408-284-2775  
www.idt.com

**for Tech Support:**  
clockhelp@idt.com