



2.5V CMOS 1-TO-10 CLOCK DRIVER

IDT74FCT20807

FEATURES:

- High frequency > 150MHz
- Guaranteed low skew < 150ps (max.) between any two outputs
- Very low duty cycle distortion < 300ps
- High speed: propagation delay < 3ns
- Very low CMOS power levels
- TTL compatible inputs and outputs
- 1:10 fanout
- Maximum output rise and fall time < 1.25ns (max.)
- Low input capacitance: 3pF typical
- 2.5V supply voltage
- Available in SSOP and QSOP packages

DESCRIPTION:

The FCT20807 is a 2.5V compatible, high speed, low noise, 1:10 fanout, non-inverting clock buffer. The large fanout from a single input reduces loading on the preceding driver and provides an efficient clock distribution network. Providing output to output skew as low as 150ps, the FCT20807 is an ideal clock distribution device for synchronous systems. Multiple power and grounds reduce noise. Typical applications are clock and signal distribution.

FUNCTIONAL BLOCK DIAGRAM

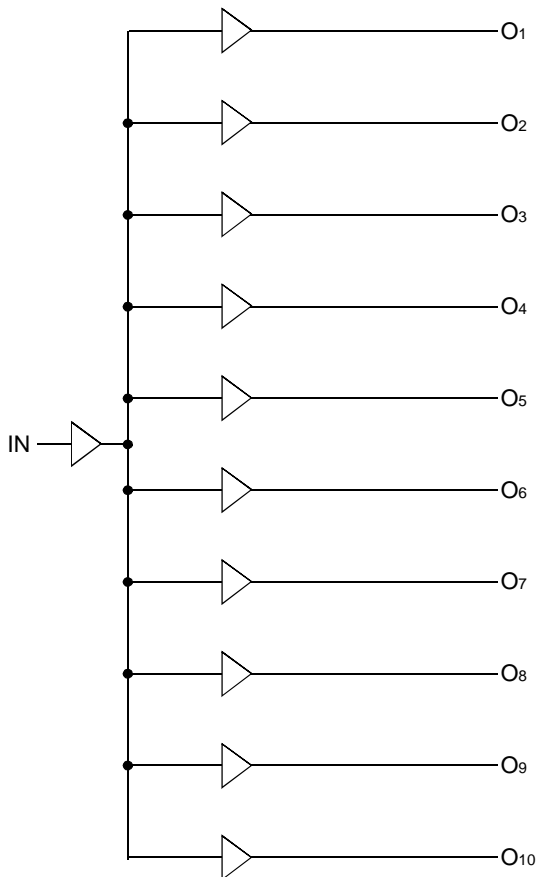

PIN CONFIGURATION

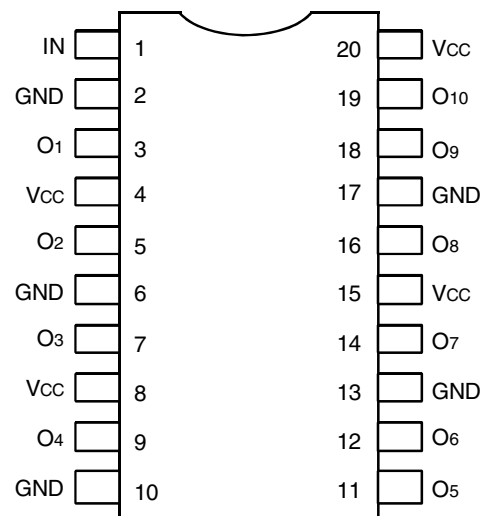

SSOP/ QSOP
TOP VIEW

The IDT logo is a registered trademark of Integrated Device Technology, Inc.

INDUSTRIAL TEMPERATURE RANGE

MAY 2010

ABSOLUTE MAXIMUM RATINGS⁽¹⁾

Symbol	Description	Max	Unit
V _{TERM} ⁽²⁾	Terminal Voltage with Respect to GND	-0.5 to +4.6	V
V _{TERM} ⁽³⁾	Terminal Voltage with Respect to GND	-0.5 to +5.5	V
V _{TERM} ⁽⁴⁾	Terminal Voltage with Respect to GND	-0.5 to V _{CC} +0.5	V
T _{STG}	Storage Temperature	-65 to +150	°C
I _{OUT}	DC Output Current	-60 to +60	mA

NOTES:

- Stresses greater than those listed under ABSOLUTE MAXIMUM RATINGS may cause permanent damage to the device. This is a stress rating only and functional operation of the device at these or any other conditions above those indicated in the operational sections of this specification is not implied. Exposure to absolute maximum rating conditions for extended periods may affect reliability.
- V_{CC} terminals.
- Input terminals.
- Outputs and I/O terminals.

CAPACITANCE (T_A = +25°C, f = 1.0MHz)

Symbol	Parameter ⁽¹⁾	Conditions	Typ.	Max.	Unit
C _{IN}	Input Capacitance	V _{IN} = 0V	3	4	pF
C _{OUT}	Output Capacitance	V _{OUT} = 0V	—	6	pF

NOTE:

- This parameter is measured at characterization but not tested.

PIN DESCRIPTION

Pin Names	Description
IN	Clock Inputs
Ox	Clock Outputs

POWER SUPPLY CHARACTERISTICS

Symbol	Parameter	Test Conditions ⁽¹⁾	Min.	Typ. ⁽²⁾	Max.	Unit
I _{CC}	Quiescent Power Supply Current	V _{CC} = Max.	—	0.1	20	μA
I _{CC} H	TTL Inputs HIGH	V _{IN} = GND or V _{CC}	—	—	—	—
ΔI _{CC}	Power Supply Current per Input HIGH	V _{CC} = Max. V _{IN} = V _{CC} - 0.6V	—	45	300	μA
I _{CC} D	Dynamic Power Supply Current per Output ⁽³⁾	V _{CC} = 2.7V 15 pF	—	40	—	μA /MHz
I _C	Total Power Supply Current ⁽⁴⁾	V _{CC} = Max. C _L = 12pF All outputs toggling f _i = 150MHz	—	65	90	mA
		V _{IN} = V _{CC} V _{IN} = GND	—	75	100	

NOTES:

- For conditions shown as Max. or Min., use appropriate value specified under Electrical Characteristics for the applicable device type.
- Typical values are at V_{CC} = 2.5V, +25°C ambient.
- This parameter is not directly testable, but is derived for use in Total Power Supply calculations.
- I_C = I_{QUIESCENT} + I_{INPUTS} + I_{DYNAMIC}
 $I_C = I_{CC} + \Delta I_{CC} D_H N_T + I_{CCD}(f_i)$
 I_{CC} = Quiescent Current (I_{CC}, I_{CC}H and I_{CC}Z)
 ΔI_{CC} = Power Supply Current for a TTL High Input (V_{IN} = V_{CC} - 0.6V)
 D_H = Duty Cycle for TTL Inputs High
 N_T = Number of TTL Inputs at D_H
 I_{CCD} = Dynamic Current Caused by an Input Transition Pair (HLH or LHL)
 f_i = Input Frequency

DC ELECTRICAL CHARACTERISTICS OVER OPERATING RANGE

Following Conditions Apply Unless Otherwise Specified

Industrial: $T_A = -40^\circ\text{C}$ to $+85^\circ\text{C}$, $V_{CC} = 2.5\text{V} \pm 0.2\text{V}$

Symbol	Parameter	Test Conditions ⁽¹⁾	Min.	Typ. ⁽²⁾	Max.	Unit
V_{IH}	Input HIGH Level		1.7	—	—	V
V_{IL}	Input LOW Level		—	—	0.7	V
I_{IH}	Input HIGH Current (Input pins)	$V_{CC} = \text{Max.}, V_I = V_{CC}$	—	—	± 1	mA
I_{IL}	Input LOW Current (Input pins)	$V_{CC} = \text{Max.}, V_I = \text{GND}$	—	—	± 1	mA
V_{IK}	Clamp Diode Voltage	$V_{CC} = \text{Min.}, I_{IN} = -18\text{mA}$	—	-0.7	-1	V
I_{ODH}	Output HIGH Current	$V_{CC} = 2.5\text{V}, V_{IN} = V_{IH}$ or $V_{IL}, V_O = 1.25\text{V}^{(3)}$	-25	-45	-100	mA
I_{ODL}	Output LOW Current	$V_{CC} = 2.5\text{V}, V_{IN} = V_{IH}$ or $V_{IL}, V_O = 1.25\text{V}^{(3)}$	20	55	120	mA
V_{OH}	Output HIGH Voltage	$V_{CC} = \text{Min.}, I_{OH} = -1\text{mA}$	$V_{CC} - 0.2$	—	—	V
		$V_{IN} = V_{IH}$ or $V_{IL}, I_{OH} = -8\text{mA}$	1.8 ⁽⁵⁾	—	—	
V_{OL}	Output LOW Voltage	$V_{CC} = \text{Min.}, I_{OL} = 1\text{mA}$	—	—	0.4	V
		$V_{IN} = V_{IH}$ or $V_{IL}, I_{OL} = 8\text{mA}$	—	—	0.6	
I_{OS}	Short Circuit Current ⁽⁴⁾	$V_{CC} = \text{Max.}, V_O = \text{GND}^{(3)}$	-25	-60	-135	mA

NOTES:

1. For conditions shown as Max. or Min., use appropriate value specified under Electrical Characteristics for the applicable device type.
2. Typical values are at $V_{CC} = 2.5\text{V}, +25^\circ\text{C}$ ambient.
3. Not more than one output should be shorted at one time. Duration of the test should not exceed one second.
4. This parameter is guaranteed but not tested.
5. $V_{OH} = V_{CC} - 0.6\text{V}$ at rated current.

SWITCHING CHARACTERISTICS OVER OPERATING RANGE^(1,2)

Following Conditions Apply Unless Otherwise Specified

Industrial: $T_A = -40^\circ\text{C}$ to $+85^\circ\text{C}$, $V_{CC} = 2.5\text{V} \pm 0.2\text{V}$

Symbol	Parameter	Conditions ⁽³⁾	Min.	Typ.	Max.	Unit
t_{PLH} t_{PHL}	Propagation Delay	CL = 22pF 100 MHz	—	3	3.5	ns
t_R	Output Rise Time		—	1	1.25	ns
t_F	Output Fall Time		—	1	1.25	ns
tsk(O)	Same Device Output Pin-to-Pin Skew ⁽⁴⁾		—	100	150	ps
tsk(P)	Pulse Skew ⁽⁵⁾		—	250	300	ps
tsk(PP)	Part-to-Part Skew ⁽⁶⁾		—	400	600	ps

Symbol	Parameter	Conditions ^(3,7)	Min.	Typ.	Max.	Unit
t_{PLH} t_{PHL}	Propagation Delay	CL = 12pF 150 MHz	—	2.4	2.7	ns
t_R	Output Rise Time		—	1	1.2	ns
t_F	Output Fall Time		—	1	1.2	ns
tsk(O)	Same Device Output Pin-to-Pin Skew ⁽⁴⁾		—	100	150	ps
tsk(P)	Pulse Skew ⁽⁵⁾		—	250	300	ps
tsk(PP)	Part-to-Part Skew ⁽⁶⁾		—	400	600	ps

NOTES:

- t_{PLH} and t_{PHL} are production tested. All other parameters guaranteed but not production tested.
- Propagation delay range indicated by Min. and Max. limit is due to V_{CC} , operating temperature and process parameters. These propagation delay limits do not imply skew.
- See test circuits and waveforms.
- Skew measured between all outputs under identical transitions and load conditions.
- Skew measured is difference between propagation delay times t_{PHL} and t_{PLH} of same output under identical load conditions.
- Part to part skew for all outputs given identical transitions and load conditions at identical V_{CC} levels and temperature.
- Airflow of 1m/s is recommended for frequencies above 133MHz.

TEST CIRCUITS AND WAVEFORMS

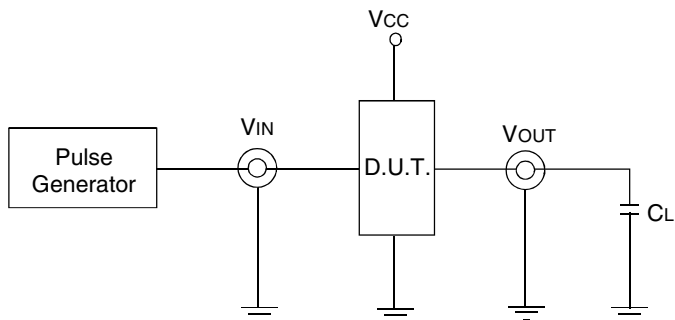

C_L = Load Capacitance: Includes Jig and Probe Capacitance

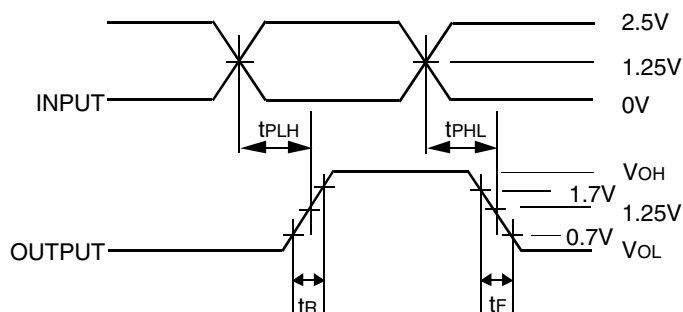

Propagation Delay

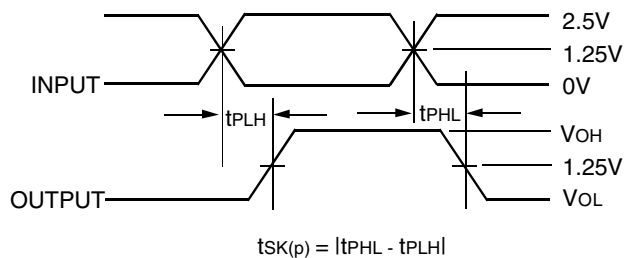

Pulse Skew - $t_{SK(P)}$

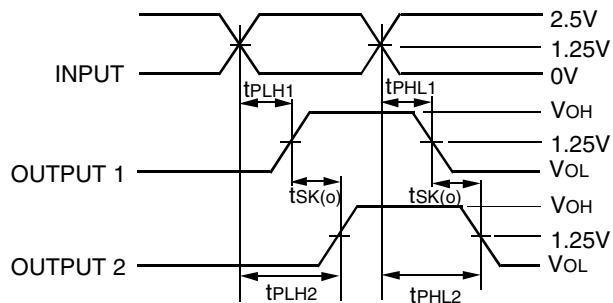

$$t_{SK(o)} = |t_{PLH2} - t_{PLH1}| \text{ or } |t_{PHL2} - t_{PHL1}|$$

Output Skew - $t_{SK(o)}$

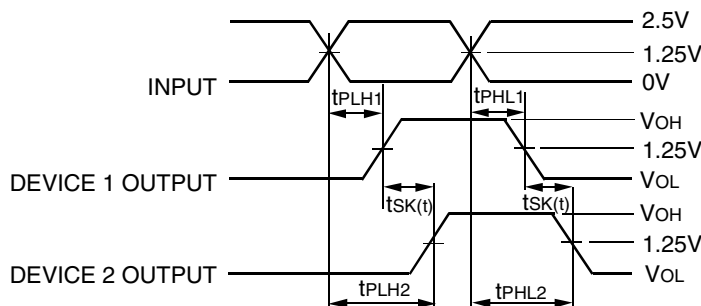

$$t_{SK(t)} = |t_{PLH2} - t_{PLH1}| \text{ or } |t_{PHL2} - t_{PHL1}|$$

Part-to-Part Skew - $t_{SK(PP)}$

NOTE: Device 1 and device 2 are same package type and speed grade.

TEST CONDITIONS

Symbol	$V_{CC} = 2.5V \pm 0.2V$	Unit
CL	22 ⁽¹⁾	pF
	12 ⁽²⁾	
RT	Z _{OUT} of pulse generator	Ω
tr / tf	1.25 ⁽¹⁾	ns
	1.2 ⁽²⁾	

DEFINITIONS:

CL = Load capacitance: includes jig and probe capacitance.
RT = Termination resistance: should be equal to Z_{OUT} of the Pulse Generator.
tr / tf = Rise/Fall time of the input stimulus from the Pulse Generator.

NOTES:

1. Test conditions at 100MHz.
2. Test conditions at 150MHz.

ORDERING INFORMATION

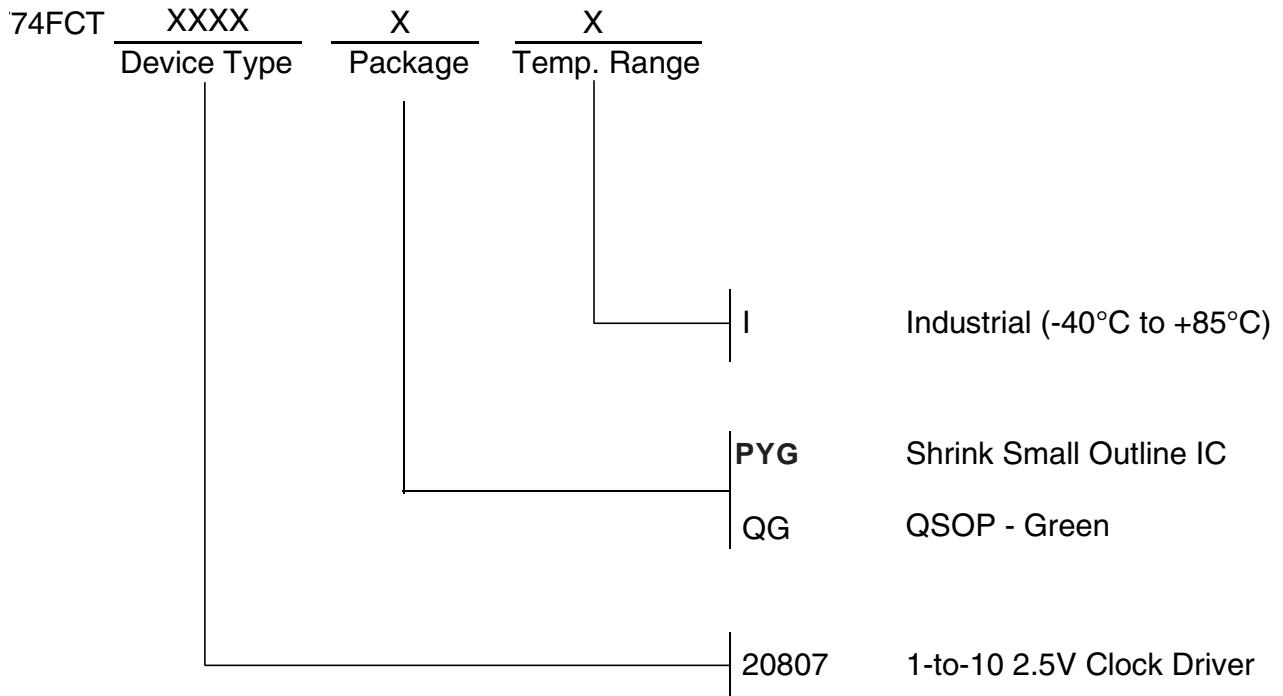

CORPORATE HEADQUARTERS
6024 Silver Creek Valley Road
San Jose, CA 95138

for SALES:
800-345-7015 or 408-284-8200
fax: 408-284-2775
www.idt.com

for Tech Support:
clockhelp@idt.com