



## 2.5V PROGRAMMABLE SKEW PLL CLOCK DRIVER TERACLOCK™

**IDT5T9010**

### FEATURES:

- 2.5 V<sub>DD</sub>
- 5 pairs of programmable skew outputs
- Low skew: 50ps same pair, 100ps all outputs
- Selectable positive or negative edge synchronization
- Tolerant of spread spectrum input clock
- Synchronous output enable
- Selectable reference input
- Input frequency: 4.17MHz to 250MHz
- Output frequency: 12.5MHz to 250MHz
- 1.8V / 2.5V LVTTTL: up to 250MHz
- HSTL / eHSTL: up to 250MHz
- Hot insertable and over-voltage tolerant inputs
- 3-level inputs for skew control
- 3-level inputs for selectable interface
- 3-level inputs for divide selection multiply/divide ratios of (1-6, 8, 10, 12) / (2, 4)
- Selectable HSTL, eHSTL, 1.8V/2.5V LVTTTL, or LVEPECL input interface
- Selectable differential or single-ended inputs and ten single-ended outputs
- PLL bypass for DC testing
- External differential feedback, internal loop filter
- Low Jitter: <75ps cycle-to-cycle
- Power-down mode
- Lock indicator
- Available in BGA package

### DESCRIPTION:

The IDT5T9010 is a 2.5V PLL clock driver intended for high performance computing and data-communications applications. A key feature of the programmable skew is the ability of outputs to lead or lag the REF input signal. The IDT5T9010 has ten programmable skew outputs in five banks of two, plus a dedicated differential feedback. Skew is controlled by 3-level input signals that may be hard-wired to appropriate high-mid-low levels. The redundant input capability allows for a smooth change over to a secondary clock source when the primary clock source is absent.

The feedback bank allows divide-by-functionality from 1 to 12 through the use of the DS[1:0] inputs. This provides the user with frequency multiplication 1 to 12 without using divided outputs for feedback. Each output bank also allows for a divide-by-functionality of 2 or 4.

The IDT5T9010 features a user-selectable, single-ended or differential input to ten single-ended outputs. The clock driver also acts as a translator from a differential HSTL, eHSTL, 1.8V/2.5V LVTTTL, LVEPECL, or single-ended 1.8V/2.5V LVTTTL input to HSTL, eHSTL, or 1.8V/2.5V LVTTTL outputs. Selectable interface is controlled by 3-level input signals that may be hard-wired to appropriate high-mid-low levels. The outputs can be synchronously enabled/disabled.

Furthermore, when PE is held high, all the outputs are synchronized with the positive edge of the REF clock input. When PE is held low, all the outputs are synchronized with the negative edge of REF.

### FUNCTIONAL BLOCK DIAGRAM

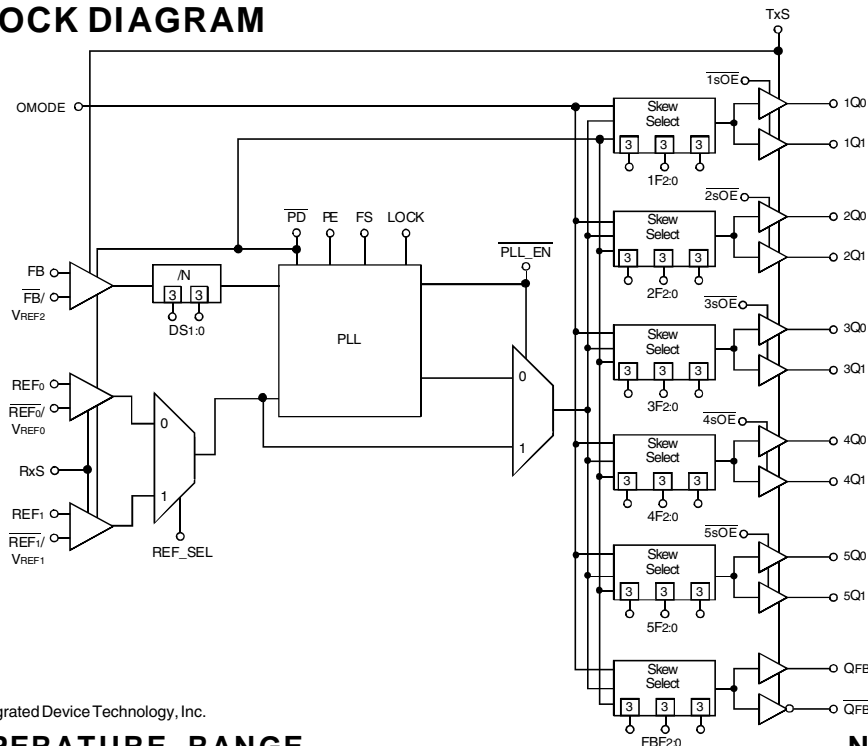

The IDT logo is a registered trademark of Integrated Device Technology, Inc.

**INDUSTRIAL TEMPERATURE RANGE**

**NOVEMBER 2004**

## PIN CONFIGURATION

	1	2	3	4	5	6	7	8	9	10	11	12	
A	V <sub>DD</sub>	1F <sub>2</sub>	$\overline{1sOE}$	1Q <sub>0</sub>	1Q <sub>1</sub>	GND	GND	2Q <sub>1</sub>	2Q <sub>0</sub>	$\overline{2sOE}$	2F <sub>2</sub>	V <sub>DDQ</sub>	A
B	V <sub>DD</sub>	V <sub>DD</sub>	V <sub>DD</sub>	1F <sub>0</sub>	1F <sub>1</sub>	GND	GND	2F <sub>1</sub>	2F <sub>0</sub>	V <sub>DDQ</sub>	V <sub>DDQ</sub>	3F <sub>2</sub>	B
C	OMODE	V <sub>DD</sub>	V <sub>DD</sub>	V <sub>DD</sub>	GND	GND	GND	GND	V <sub>DDQ</sub>	V <sub>DDQ</sub>	V <sub>DDQ</sub>	$\overline{3sOE}$	C
D	REF <sub>-</sub> SEL	V <sub>DD</sub>	V <sub>DD</sub>	V <sub>DD</sub>	GND	GND	GND	GND	V <sub>DDQ</sub>	V <sub>DDQ</sub>	3F <sub>0</sub>	3Q <sub>0</sub>	D
E	REF <sub>1</sub>	$\overline{REF_1}$ /V <sub>REF1</sub>	NC	V <sub>DD</sub>	GND	GND	GND	GND	V <sub>DDQ</sub>	V <sub>DDQ</sub>	3F <sub>1</sub>	3Q <sub>1</sub>	E
F	REF <sub>0</sub>	$\overline{REF_0}$ /V <sub>REF0</sub>	V <sub>DD</sub>	V <sub>DD</sub>	GND	GND	GND	GND	V <sub>DDQ</sub>	V <sub>DDQ</sub>	V <sub>DDQ</sub>	V <sub>DDQ</sub>	F
G	FB	$\overline{FB}$ /V <sub>REF2</sub>	V <sub>DD</sub>	V <sub>DD</sub>	GND	GND	GND	GND	V <sub>DDQ</sub>	V <sub>DDQ</sub>	V <sub>DDQ</sub>	V <sub>DDQ</sub>	G
H	$\overline{PD}$	$\overline{PLL}$ EN	PE	V <sub>DD</sub>	GND	GND	GND	GND	V <sub>DDQ</sub>	V <sub>DDQ</sub>	4F <sub>1</sub>	4Q <sub>1</sub>	H
J	RxS	TxS	V <sub>DD</sub>	V <sub>DD</sub>	GND	GND	GND	GND	V <sub>DDQ</sub>	V <sub>DDQ</sub>	4F <sub>0</sub>	4Q <sub>0</sub>	J
K	LOCK	V <sub>DD</sub>	V <sub>DD</sub>	V <sub>DD</sub>	GND	GND	GND	GND	V <sub>DDQ</sub>	V <sub>DDQ</sub>	V <sub>DDQ</sub>	$\overline{4sOE}$	K
L	V <sub>DD</sub>	V <sub>DD</sub>	FS	FBF <sub>0</sub>	FBF <sub>1</sub>	GND	GND	5F <sub>1</sub>	5F <sub>0</sub>	V <sub>DDQ</sub>	V <sub>DDQ</sub>	4F <sub>2</sub>	L
M	DS <sub>1</sub>	DS <sub>0</sub>	FBF <sub>2</sub>	QFB	$\overline{QFB}$	GND	GND	5Q <sub>1</sub>	5Q <sub>0</sub>	$\overline{5sOE}$	5F <sub>2</sub>	V <sub>DDQ</sub>	M
	1	2	3	4	5	6	7	8	9	10	11	12	

## ABSOLUTE MAXIMUM RATINGS<sup>(1)</sup>

Symbol	Description	Max	Unit
V <sub>DDQ</sub> , V <sub>DD</sub>	Power Supply Voltage <sup>(2)</sup>	-0.5 to +3.6	V
V <sub>I</sub>	Input Voltage	-0.5 to +3.6	V
V <sub>O</sub>	Output Voltage	-0.5 to V <sub>DDQ</sub> +0.5	V
V <sub>REF</sub>	Reference Voltage <sup>(3)</sup>	-0.5 to +3.6	V
T <sub>J</sub>	Junction Temperature	150	°C
T <sub>STG</sub>	Storage Temperature	-65 to +165	°C

### NOTES:

- Stresses greater than those listed under ABSOLUTE MAXIMUM RATINGS may cause permanent damage to the device. This is a stress rating only and functional operation of the device at these or any other conditions above those indicated in the operational sections of this specification is not implied. Exposure to absolute maximum rating conditions for extended periods may affect reliability.
- V<sub>DDQ</sub> and V<sub>DD</sub> internally operate independently. No power sequencing requirements need to be met.
- Not to exceed 3.6V.

## CAPACITANCE (T<sub>A</sub> = +25°C, f = 1MHz, V<sub>IN</sub> = 0V)

Parameter	Description	Min.	Typ.	Max.	Unit
C <sub>IN</sub>	Input Capacitance	2.5	3	3.5	pF
C <sub>OUT</sub>	Output Capacitance	—	6.3	7	pF

### NOTE:

- Capacitance applies to all inputs except RxS, TxS, nF<sub>[2:0]</sub>, FBF<sub>[2:0]</sub>, and DS<sub>[1:0]</sub>.

## RECOMMENDED OPERATING RANGE

Symbol	Description	Min.	Typ.	Max.	Unit
T <sub>A</sub>	Ambient Operating Temperature	-40	+25	+85	°C
V <sub>DD</sub> <sup>(1)</sup>	Internal Power Supply Voltage	2.3	2.5	2.7	V
V <sub>DDQ</sub> <sup>(1)</sup>	HSTL Output Power Supply Voltage	1.4	1.5	1.6	V
	Extended HSTL and 1.8V LVTTTL Output Power Supply Voltage	1.65	1.8	1.95	V
	2.5V LVTTTL Output Power Supply Voltage		V <sub>DD</sub>		V
V <sub>T</sub>	Termination Voltage		V <sub>DDQ</sub> / 2		V

### NOTE:

- All power supplies should operate in tandem. If V<sub>DD</sub> or V<sub>DDQ</sub> is at maximum, then V<sub>DDQ</sub> or V<sub>DD</sub> (respectively) should be at maximum, and vice-versa.

## PIN DESCRIPTION

Symbol	I/O	Type	Description
REF <sub>[1:0]</sub>	I	Adjustable <sup>(1)</sup>	Clock input. REF <sub>[1:0]</sub> is the "true" side of the differential clock input. If operating in single-ended mode, REF <sub>[1:0]</sub> is the clock input.
$\overline{\text{REF}}_{[1:0]}$ / V <sub>REF<sub>[1:0]</sub></sub>	I	Adjustable <sup>(1)</sup>	Complementary clock input. $\overline{\text{REF}}_{[1:0]}$ /V <sub>REF<sub>[1:0]</sub></sub> is the "complementary" side of REF <sub>[1:0]</sub> if the input is in differential mode. If operating in single-ended mode, $\overline{\text{REF}}_{[1:0]}$ /V <sub>REF<sub>[1:0]</sub></sub> is left floating. For single-ended operation in differential mode, $\overline{\text{REF}}_{[1:0]}$ /V <sub>REF<sub>[1:0]</sub></sub> should be set to the desired toggle voltage for REF <sub>[1:0]</sub> : 2.5V LVTTTL                      V <sub>REF</sub> = 1250mV (SSTL2 compatible) 1.8V LVTTTL, eHSTL           V <sub>REF</sub> = 900mV HSTL                                      V <sub>REF</sub> = 750mV LVEPECL                              V <sub>REF</sub> = 1082mV
FB	I	Adjustable <sup>(1)</sup>	Clock input. FB is the "true" side of the differential feedback clock input. If operating in single-ended mode, FB is the feedback clock input.
$\overline{\text{FB}}$ /V <sub>REF2</sub>	I	Adjustable <sup>(1)</sup>	Complementary feedback clock input. $\overline{\text{FB}}$ /V <sub>REF2</sub> is the "complementary" side of FB if the input is in differential mode. If operating in single-ended mode, $\overline{\text{FB}}$ /V <sub>REF2</sub> is left floating. For single-ended operation in differential mode, $\overline{\text{FB}}$ /V <sub>REF2</sub> should be set to the desired toggle voltage for FB: 2.5V LVTTTL                      V <sub>REF</sub> = 1250mV (SSTL2 compatible) 1.8V LVTTTL, eHSTL           V <sub>REF</sub> = 900mV HSTL                                      V <sub>REF</sub> = 750mV LVEPECL                              V <sub>REF</sub> = 1082mV

### NOTE:

- Inputs are capable of translating the following interface standards. User can select between:

Single-ended 2.5V LVTTTL levels

Single-ended 1.8V LVTTTL levels

or

Differential 2.5V/1.8V LVTTTL levels

Differential HSTL and eHSTL levels

Differential LVEPECL levels

## PIN DESCRIPTION, CONTINUED

Symbol	I/O	Type	Description
REF_SEL	I	LVTTL <sup>(1)</sup>	Reference clock select. When LOW, selects REF <sub>0</sub> and $\overline{\text{REF}}_0/V_{\text{REF}0}$ . When HIGH, selects REF <sub>1</sub> and $\overline{\text{REF}}_1/V_{\text{REF}1}$ .
$\overline{\text{nsOE}}$	I	LVTTL <sup>(1)</sup>	Synchronous output enable. When $\overline{\text{nsOE}}$ is HIGH, nQ <sub>[1:0]</sub> are synchronously stopped. OMODE selects whether the outputs are gated LOW/HIGH or tri-stated. When OMODE is HIGH, PE determines the level at which the outputs stop. When PE is LOW/HIGH, the nQ <sub>[1:0]</sub> is stopped in a HIGH/LOW state. When OMODE is LOW, the outputs are tri-stated. Set $\overline{\text{nsOE}}$ LOW for normal operation.
QFB	O	Adjustable <sup>(2)</sup>	Feedback clock output
$\overline{\text{QFB}}$	O	Adjustable <sup>(2)</sup>	Complementary feedback clock output
nQ <sub>[1:0]</sub>	O	Adjustable <sup>(2)</sup>	Five banks of two outputs
RxS	I	3-Level <sup>(3)</sup>	Selects single-ended 2.5V LVTTL (HIGH), 1.8V LVTTL (MID) REF clock input or differential (LOW) REF clock input
TxS	I	3-Level <sup>(3)</sup>	Sets the drive strength of the output drivers and feedback inputs to be 2.5V LVTTL (HIGH), 1.8V LVTTL (MID) or HSTL/eHSTL (LOW) compatible. Used in conjunction with V <sub>DDQ</sub> to set the interface levels.
PE	I	LVTTL <sup>(1)</sup>	Selectable positive or negative edge control. When LOW/HIGH the outputs are synchronized with the negative/positive edge of the reference clock (has internal pull-up).
nF <sub>[2:0]</sub>	I	3-Level <sup>(3)</sup>	3-level inputs for selecting 1 to 18 skew taps or frequency functions (See Control Summary table)
FBF <sub>[2:0]</sub>	I	3-Level <sup>(3)</sup>	3-level inputs for selecting 1 to 18 skew taps or frequency functions (See Control Summary table)
FS	I	LVTTL <sup>(1)</sup>	Selects appropriate oscillator circuit based on anticipated frequency range (See Programmable Skew Range)
DS <sub>[1:0]</sub>	I	3-Level <sup>(3)</sup>	3-level inputs for feedback input divider selection (See Divide Selection table)
PLL_EN	I	LVTTL <sup>(1)</sup>	PLL enable/disable control. Set LOW for normal operation. When PLL_EN is HIGH, the PLL is disabled and REF <sub>[1:0]</sub> goes to all outputs.
$\overline{\text{PD}}$	I	LVTTL <sup>(1)</sup>	Power down control. When $\overline{\text{PD}}$ is LOW, the inputs are disabled and internal switching is stopped. OMODE selects whether the outputs are gated LOW/HIGH or tri-stated. When OMODE is HIGH, PE determines the level at which the outputs stop. When PE is LOW/HIGH, the nQ <sub>[1:0]</sub> and QFB are stopped in a HIGH/LOW state, while the $\overline{\text{QFB}}$ is stopped in a LOW/HIGH state. When OMODE is LOW, the outputs are tri-stated. Set $\overline{\text{PD}}$ HIGH for normal operation.
LOCK	O	LVTTL	PLL lock indication signal. HIGH indicates lock. LOW indicates that the PLL is not locked and outputs may not be synchronized to the inputs. (For more information on application specific use of the LOCK pin, please see AN237.)
OMODE	I	LVTTL <sup>(1)</sup>	Output disable control. Determines the outputs' disable state. Used in conjunction with $\overline{\text{nsOE}}$ and $\overline{\text{PD}}$ . (See Output Enable/Disable and Powerdown tables.)
V <sub>DDQ</sub>		PWR	Power supply for output buffers. When using 2.5V LVTTL, V <sub>DDQ</sub> should be connected to V <sub>DD</sub> .
V <sub>DD</sub>		PWR	Power supply for phase locked loop, lock output, inputs, and other internal circuitry
GND		PWR	Ground

### NOTES:

1. Pins listed as LVTTL inputs will accept 2.5V signals under all conditions. If the output is operating at 1.8V or 1.5V, the LVTTL inputs will accept the 1.8V LVTTL signals as well.
2. Outputs are user selectable to drive 2.5V, 1.8V LVTTL, eHSTL, or HSTL interface levels when used with the appropriate V<sub>DDQ</sub> voltage.
3. 3-level inputs are static inputs and must be tied to V<sub>DD</sub> or GND or left floating. These inputs are not hot-insertable or over voltage tolerant.

## OUTPUT ENABLE/DISABLE

$\overline{\text{nsOE}}$	OMODE	Output
L	X	Normal Operation
H	L	Tri-State
H	H	Gated <sup>(1)</sup>

### NOTE:

1. PE determines the level at which the outputs stop. When PE is LOW/HIGH, the nQ<sub>[1:0]</sub> is stopped in a HIGH/LOW state.

## POWERDOWN

$\overline{\text{PD}}$	OMODE	Output
H	X	Normal Operation
L	L	Tri-State
L	H	Gated <sup>(1)</sup>

### NOTE:

1. PE determines the level at which the outputs stop. When PE is LOW/HIGH, the nQ<sub>[1:0]</sub> and QFB are stopped in a HIGH/LOW state, while the  $\overline{\text{QFB}}$  is stopped in a LOW/HIGH state.

## PROGRAMMABLE SKEW

Output skew with respect to the REF<sub>[1:0]</sub> and  $\overline{\text{REF}}_{[1:0]}/\text{VREF}_{[1:0]}$  input is adjustable to compensate for PCB trace delays, backplane propagation delays or to accommodate requirements for special timing relationships between clocked components. Skew is selectable as a multiple of a time unit (tu) which ranges from 250ps to 1.25ns (see Programmable Skew Range and Resolution Table). There are 18 skew/divide configurations available for each output pair. These configurations are chosen

by the nF<sub>[2:0]</sub>/FBF<sub>[2:0]</sub> control pins. In order to minimize the number of control pins, 3-level inputs (HIGH-MID-LOW) are used, they are intended for but not restricted to hard-wiring. Undriven 3-level inputs default to the MID level. The Control Summary Table shows how to select specific skew taps by using the nF<sub>[2:0]</sub>/FBF<sub>[2:0]</sub> control pins.

## EXTERNAL DIFFERENTIAL FEEDBACK

By providing a dedicated external differential feedback, the IDT5T9010 gives users flexibility with regard to skew adjustment. The FB and  $\overline{\text{FB}}$ /VREF<sub>2</sub> signals are compared with the input REF<sub>[1:0]</sub> and  $\overline{\text{REF}}_{[1:0]}/\text{VREF}_{[1:0]}$  signals at the phase detector in order to drive the VCO. Phase differences cause the VCO of the PLL to adjust upwards or downwards accordingly.

An internal loop filter moderates the response of the VCO to the phase detector. The loop filter transfer function has been chosen to provide minimal jitter (or frequency variation) while still providing accurate responses to input frequency changes.

## PROGRAMMABLE SKEW RANGE AND RESOLUTION TABLE

	FS = LOW	FS = HIGH	Comments
Timing Unit Calculation (tu)	$1/(16 \times \text{FNOM})$	$1/(16 \times \text{FNOM})$	
VCO Frequency Range (FNOM) <sup>(1,2)</sup>	50 to 125MHz	100 to 250MHz	
Skew Adjustment Range <sup>(3)</sup>			
Max Adjustment:	±8.75ns	±4.375ns	ns
	±157.5°	±157.5°	Phase Degrees
	±43.75%	±43.75%	% of Cycle Time
Example 1, FNOM = 50MHz	tu = 1.25ns	—	
Example 2, FNOM = 75MHz	tu = 0.833ns	—	
Example 3, FNOM = 100MHz	tu = 0.625ns	tu = 0.625ns	
Example 4, FNOM = 150MHz	—	tu = 0.417ns	
Example 5, FNOM = 200MHz	—	tu = 0.313ns	
Example 6, FNOM = 250MHz	—	tu = 0.25ns	

### NOTES:

- The device may be operated outside recommended frequency ranges without damage, but functional operation is not guaranteed.
- The level to be set on FS is determined by the nominal operating frequency of the VCO and Time Unit Generator. The VCO frequency always appears at nQ<sub>[1:0]</sub> outputs when they are operated in their undivided modes. The frequency appearing at the REF<sub>[1:0]</sub> and  $\overline{\text{REF}}_{[1:0]}/\text{VREF}_{[1:0]}$  and FB and  $\overline{\text{FB}}/\text{VREF}_2$  inputs will be FNOM when the QFB and  $\overline{\text{QFB}}$  are undivided and DS<sub>[1:0]</sub> = MM. The frequency of the REF<sub>[1:0]</sub> and  $\overline{\text{REF}}_{[1:0]}/\text{VREF}_{[1:0]}$  and FB and  $\overline{\text{FB}}/\text{VREF}_2$  inputs will be FNOM /2 or FNOM /4 when the part is configured for frequency multiplication by using a divided QFB and  $\overline{\text{QFB}}$  and setting DS<sub>[1:0]</sub> = MM. Using the DS<sub>[1:0]</sub> inputs allows a different method for frequency multiplication (see Divide Selection Table).
- Skew adjustment range assumes that a zero skew output is used for feedback. If a skewed QFB and  $\overline{\text{QFB}}$  output is used for feedback, then adjustment range will be greater. For example if a 4tu skewed output is used for feedback, all other outputs will be skewed -4tu in addition to whatever skew value is programmed for those outputs. 'Max adjustment' range applies to all output pairs where ±7tu skew adjustment is possible and at the lowest FNOM value.

## DIVIDE SELECTION TABLE

DS [1:0]	Divide-by-n	Permitted Output Divide-by-n connected to FB and $\overline{FB}/V_{REF2}^{(1)}$
LL	2	1, 2
LM	3	1
LH	4	1, 2
ML	5	1, 2
MM	1	1, 2, 4
MH	6	1, 2
HL	8	1
HM	10	1
HH	12	1

**NOTE:**  
1. Permissible output division ratios connected to FB and  $\overline{FB}/V_{REF2}$ . The frequencies of the REF[1:0] and  $\overline{REF}[1:0]/V_{REF[1:0]}$  inputs will be  $F_{NOM}/N$  when the parts are configured for frequency multiplication by using an undivided output for FB and  $\overline{FB}/V_{REF2}$  and setting DS[1:0] to N (N = 1-6, 8, 10, 12).

## CONTROL SUMMARY TABLE FOR ALL OUTPUTS<sup>(1)</sup>

nF2/FBF2	nF1/FBF1	nF0/FBF0	Output Skew
L	L	L	Divide by 2
L	L	M	+7t <sub>U</sub>
L	L	H	+6t <sub>U</sub>
L	M	L	+5t <sub>U</sub>
L	M	M	+4t <sub>U</sub>
L	M	H	+3t <sub>U</sub>
L	H	L	+2t <sub>U</sub>
L	H	M	+1t <sub>U</sub>
L	H	H	Zero Skew
H	L	L	Inverted
H	L	M	-1t <sub>U</sub>
H	L	H	-2t <sub>U</sub>
H	M	L	-3t <sub>U</sub>
H	M	M	-4t <sub>U</sub>
H	M	H	-5t <sub>U</sub>
H	H	L	-6t <sub>U</sub>
H	H	M	-7t <sub>U</sub>
H	H	H	Divide by 4

**NOTE:**  
1. When PLL\_EN is HIGH, the PLL is disabled and the device is put into test mode. In test mode, 5F[2:0] must be set to MHL, the REF[1:0]/ $\overline{REF}[1:0]$  input frequency must be set to 1MHz or less, and nF[2:0]/FBF[2:0] pins should be set to LHH.

## INPUT/OUTPUT SELECTION<sup>(1)</sup>

Input	Output	Input	Output		
2.5V LVTTTL SE	2.5V LVTTTL	2.5V LVTTTL SE	eHSTL		
1.8V LVTTTL SE		1.8V LVTTTL SE			
2.5V LVTTTL DSE		2.5V LVTTTL DSE			
1.8V LVTTTL DSE		1.8V LVTTTL DSE			
LVEPECL DSE		LVEPECL DSE			
eHSTL DSE		eHSTL DSE			
HSTL DSE		HSTL DSE			
2.5V LVTTTL DIF		2.5V LVTTTL DIF			
1.8V LVTTTL DIF		1.8V LVTTTL DIF			
LVEPECL DIF		LVEPECL DIF			
eHSTL DIF		eHSTL DIF			
HSTL DIF		HSTL DIF			
2.5V LVTTTL SE		1.8V LVTTTL		2.5V LVTTTL SE	HSTL
1.8V LVTTTL SE				1.8V LVTTTL SE	
2.5V LVTTTL DSE	2.5V LVTTTL DSE				
1.8V LVTTTL DSE	1.8V LVTTTL DSE				
LVEPECL DSE	LVEPECL DSE				
eHSTL DSE	eHSTL DSE				
HSTL DSE	HSTL DSE				
2.5V LVTTTL DIF	2.5V LVTTTL DIF				
1.8V LVTTTL DIF	1.8V LVTTTL DIF				
LVEPECL DIF	LVEPECL DIF				
eHSTL DIF	eHSTL DIF				
HSTL DIF	HSTL DIF				

**NOTE:**  
1. The INPUT/OUTPUT SELECTION Table describes the total possible combinations of input and output interfaces. Single-Ended (SE) inputs in a single-ended mode require the REF<sub>[1:0]</sub>/VREF<sub>[1:0]</sub> and FB/VREF<sub>2</sub> pins to be left floating. Differential Single-Ended (DSE) is for single-ended operation in differential mode, requiring VREF<sub>[1:0]</sub> and VREF<sub>2</sub>. Differential (DIF) inputs are used only in differential mode.

## DC ELECTRICAL CHARACTERISTICS OVER OPERATING RANGE

Symbol	Parameter	Test Conditions	Min.	Max.	Unit
V <sub>IHH</sub>	Input HIGH Voltage Level <sup>(1)</sup>	3-Level Inputs Only	V <sub>DD</sub> - 0.4	—	V
V <sub>IMM</sub>	Input MID Voltage Level <sup>(1)</sup>	3-Level Inputs Only	V <sub>DD</sub> /2 - 0.2	V <sub>DD</sub> /2 + 0.2	V
V <sub>ILL</sub>	Input LOW Voltage Level <sup>(1)</sup>	3-Level Inputs Only	—	0.4	V
I <sub>3</sub>	3-Level Input DC Current (RxS, TxS, nF <sub>[2:0]</sub> , FBF <sub>[2:0]</sub> , DS <sub>[1:0]</sub> )	V <sub>IN</sub> = V <sub>DD</sub> HIGH Level	—	200	μA
		V <sub>IN</sub> = V <sub>DD</sub> /2      MID Level	-50	+50	
		V <sub>IN</sub> = GND      LOW Level	-200	—	
I <sub>PU</sub>	Input Pull-Up Current (PE)	V <sub>DD</sub> = Max., V <sub>IN</sub> = GND	-100	—	μA

**NOTE:**  
1. These inputs are normally wired to V<sub>DD</sub>, GND, or left floating. Internal termination resistors bias unconnected inputs to V<sub>DD</sub>/2. If these inputs are switched dynamically after powerup, the function and timing of the outputs may be glitched, and the PLL may require additional t<sub>lock</sub> time before all datasheet limits are achieved.

## DC ELECTRICAL CHARACTERISTICS OVER OPERATING RANGE FOR HSTL<sup>(1)</sup>

Symbol	Parameter	Test Conditions	Min.	Typ. <sup>(7)</sup>	Max	Unit
<b>Input Characteristics</b>						
I <sub>IH</sub>	Input HIGH Current	V <sub>DD</sub> = 2.7V V <sub>I</sub> = V <sub>DDQ</sub> /GND	—	—	±5	μA
I <sub>IL</sub>	Input LOW Current	V <sub>DD</sub> = 2.7V V <sub>I</sub> = GND/V <sub>DDQ</sub>	—	—	±5	
V <sub>IK</sub>	Clamp Diode Voltage	V <sub>DD</sub> = 2.3V, I <sub>IN</sub> = -18mA	—	-0.7	-1.2	V
V <sub>IN</sub>	DC Input Voltage		-0.3		+3.6	V
V <sub>DIF</sub>	DC Differential Voltage <sup>(2,8)</sup>		0.2		—	V
V <sub>CM</sub>	DC Common Mode Input Voltage <sup>(3,8)</sup>		680	750	900	mV
V <sub>IH</sub>	DC Input HIGH <sup>(4,5,8)</sup>		V <sub>REF</sub> + 100		—	mV
V <sub>IL</sub>	DC Input LOW <sup>(4,6,8)</sup>		—		V <sub>REF</sub> - 100	mV
V <sub>REF</sub>	Single-Ended Reference Voltage <sup>(4,8)</sup>		—	750	—	mV
<b>Output Characteristics</b>						
V <sub>OH</sub>	Output HIGH Voltage	I <sub>OH</sub> = -8mA	V <sub>DDQ</sub> - 0.4		—	V
		I <sub>OH</sub> = -100μA	V <sub>DDQ</sub> - 0.1		—	
V <sub>OL</sub>	Output LOW Voltage	I <sub>OL</sub> = 8mA	—		0.4	V
		I <sub>OL</sub> = 100μA	—		0.1	
V <sub>OX</sub>	FB/FB Output Crossing Point		V <sub>DDQ</sub> /2 - 150	V <sub>DDQ</sub> /2	V <sub>DDQ</sub> /2 + 150	mV

**NOTES:**

- See RECOMMENDED OPERATING RANGE table.
- V<sub>DIF</sub> specifies the minimum input differential voltage (V<sub>TR</sub> - V<sub>CP</sub>) required for switching where V<sub>TR</sub> is the "true" input level and V<sub>CP</sub> is the "complement" input level. Differential mode only. The DC differential voltage must be maintained to guarantee retaining the existing HIGH or LOW input. The AC differential voltage must be achieved to guarantee switching to a new state.
- V<sub>CM</sub> specifies the maximum allowable range of (V<sub>TR</sub> + V<sub>CP</sub>) /2. Differential mode only.
- For single-ended operation, in differential mode,  $\overline{\text{REF}}_{[1:0]}/\text{VREF}_{[1:0]}$  is tied to the DC voltage V<sub>REF[1:0]</sub>.
- Voltage required to maintain a logic HIGH, single-ended operation in differential mode.
- Voltage required to maintain a logic LOW, single-ended operation in differential mode.
- Typical values are at V<sub>DD</sub> = 2.5V, V<sub>DDQ</sub> = 1.5V, +25°C ambient.
- The reference clock input is capable of HSTL, eHSTL, LVEPECL, 1.8V or 2.5V LVTTTL operation independent of the device output. (See Input/Output Selection table.)

## POWER SUPPLY CHARACTERISTICS FOR HSTL OUTPUTS<sup>(1)</sup>

Symbol	Parameter	Test Conditions <sup>(2)</sup>	Typ.	Max	Unit
I <sub>DDQ</sub>	Quiescent V <sub>DD</sub> Power Supply Current <sup>(3)</sup>	V <sub>DDQ</sub> = Max., REF = LOW, $\overline{\text{PD}}$ = HIGH, $\overline{\text{nSOE}}$ = LOW, $\overline{\text{PLL\_EN}}$ = HIGH, DS <sub>[1:0]}</sub> = MM, nF <sub>[2:0]}</sub> = LHH, FBF <sub>[2:0]}</sub> = LHH, Outputs enabled, All outputs unloaded	100	150	mA
I <sub>DDQQ</sub>	Quiescent V <sub>DDQ</sub> Power Supply Current <sup>(3)</sup>	V <sub>DDQ</sub> = Max., REF = LOW, $\overline{\text{PD}}$ = HIGH, $\overline{\text{nSOE}}$ = LOW, $\overline{\text{PLL\_EN}}$ = HIGH, DS <sub>[1:0]}</sub> = MM, nF <sub>[2:0]}</sub> = LHH, FBF <sub>[2:0]}</sub> = LHH, Outputs enabled, All outputs unloaded	0.75	50	μA
I <sub>DDPD</sub>	Power Down Current	V <sub>DD</sub> = Max., $\overline{\text{PD}}$ = LOW, $\overline{\text{nSOE}}$ = LOW, $\overline{\text{PLL\_EN}}$ = HIGH	1.7	5	mA
I <sub>DDD</sub>	Dynamic V <sub>DD</sub> Power Supply Current per Output	V <sub>DD</sub> = Max., V <sub>DDQ</sub> = Max., C <sub>L</sub> = 0pF	18	30	μA/MHz
I <sub>DDQD</sub>	Dynamic V <sub>DDQ</sub> Power Supply Current per Output	V <sub>DD</sub> = Max., V <sub>DDQ</sub> = Max., C <sub>L</sub> = 0pF	19	30	μA/MHz
I <sub>TOT</sub>	Total Power V <sub>DD</sub> Supply Current <sup>(4)</sup>	V <sub>DDQ</sub> = 1.5V, F <sub>VCO</sub> = 100MHz, C <sub>L</sub> = 15pF	115	170	mA
		V <sub>DDQ</sub> = 1.5V, F <sub>VCO</sub> = 250MHz, C <sub>L</sub> = 15pF	145	220	
I <sub>TOTQ</sub>	Total Power V <sub>DDQ</sub> Supply Current <sup>(4)</sup>	V <sub>DDQ</sub> = 1.5V, F <sub>VCO</sub> = 100MHz, C <sub>L</sub> = 15pF	50	75	mA
		V <sub>DDQ</sub> = 1.5V, F <sub>VCO</sub> = 250MHz, C <sub>L</sub> = 15pF	150	225	

**NOTES:**

- These power consumption characteristics are for all the valid input interfaces and cover the worst case input and output interface combinations.
- The termination resistors are excluded from these measurements.
- If the differential input interface is used, the true input is held LOW and the complementary input is held HIGH.
- FS = HIGH.

## DIFFERENTIAL INPUT AC TEST CONDITIONS FOR HSTL

Symbol	Parameter	Value	Units
V <sub>DIF</sub>	Input Signal Swing <sup>(1)</sup>	1	V
V <sub>X</sub>	Differential Input Signal Crossing Point <sup>(2)</sup>	750	mV
V <sub>THI</sub>	Input Timing Measurement Reference Level <sup>(3)</sup>	Crossing Point	V
t <sub>R</sub> , t <sub>F</sub>	Input Signal Edge Rate <sup>(4)</sup>	1	V/ns

### NOTES:

- The 1V peak-to-peak input pulse level is specified to allow consistent, repeatable results in an automatic test equipment (ATE) environment. This device meets the V<sub>DIF</sub> (AC) specification under actual use conditions.
- A 750mV crossing point level is specified to allow consistent, repeatable results in an automatic test equipment (ATE) environment. This device meets the V<sub>X</sub> specification under actual use conditions.
- In all cases, input waveform timing is marked at the differential cross-point of the input signals.
- The input signal edge rate of 1V/ns or greater is to be maintained in the 20% to 80% range of the input waveform.

## DC ELECTRICAL CHARACTERISTICS OVER OPERATING RANGE FOR eHSTL<sup>(1)</sup>

Symbol	Parameter	Test Conditions	Min.	Typ. <sup>(7)</sup>	Max	Unit
<b>Input Characteristics</b>						
I <sub>IH</sub>	Input HIGH Current	V <sub>DD</sub> = 2.7V V <sub>I</sub> = V <sub>DDQ</sub> /GND	—	—	±5	μA
I <sub>IL</sub>	Input LOW Current	V <sub>DD</sub> = 2.7V V <sub>I</sub> = GND/V <sub>DDQ</sub>	—	—	±5	
V <sub>IK</sub>	Clamp Diode Voltage	V <sub>DD</sub> = 2.3V, I <sub>IN</sub> = -18mA	—	-0.7	-1.2	V
V <sub>IN</sub>	DC Input Voltage		-0.3		+3.6	V
V <sub>DIF</sub>	DC Differential Voltage <sup>(2,8)</sup>		0.2		—	V
V <sub>CM</sub>	DC Common Mode Input Voltage <sup>(3,8)</sup>		800	900	1000	mV
V <sub>IH</sub>	DC Input HIGH <sup>(4,5,8)</sup>		V <sub>REF</sub> + 100		—	mV
V <sub>IL</sub>	DC Input LOW <sup>(4,6,8)</sup>		—		V <sub>REF</sub> - 100	mV
V <sub>REF</sub>	Single-Ended Reference Voltage <sup>(4,8)</sup>		—	900	—	mV

### Output Characteristics

V <sub>OH</sub>	Output HIGH Voltage	I <sub>OH</sub> = -8mA	V <sub>DDQ</sub> - 0.4		—	V
		I <sub>OH</sub> = -100μA	V <sub>DDQ</sub> - 0.1		—	V
V <sub>OL</sub>	Output LOW Voltage	I <sub>OL</sub> = 8mA	—		0.4	V
		I <sub>OL</sub> = 100μA	—		0.1	V
V <sub>OX</sub>	FB/ $\overline{\text{FB}}$ Output Crossing Point		V <sub>DDQ</sub> /2 - 150	V <sub>DDQ</sub> /2	V <sub>DDQ</sub> /2 + 150	mV

### NOTES:

- See RECOMMENDED OPERATING RANGE table.
- V<sub>DIF</sub> specifies the minimum input differential voltage (V<sub>TR</sub> - V<sub>CP</sub>) required for switching where V<sub>TR</sub> is the "true" input level and V<sub>CP</sub> is the "complement" input level. Differential mode only. The DC differential voltage must be maintained to guarantee retaining the existing HIGH or LOW input. The AC differential voltage must be achieved to guarantee switching to a new state.
- V<sub>CM</sub> specifies the maximum allowable range of (V<sub>TR</sub> + V<sub>CP</sub>) /2. Differential mode only.
- For single-ended operation, in a differential mode,  $\overline{\text{REF}}_{[1:0]}/\text{VREF}_{[1:0]}$  is tied to the DC voltage V<sub>REF</sub>[1:0].
- Voltage required to maintain a logic HIGH, single-ended operation in differential mode.
- Voltage required to maintain a logic LOW, single-ended operation in differential mode.
- Typical values are at V<sub>DD</sub> = 2.5V, V<sub>DDQ</sub> = 1.8V, +25°C ambient.
- The reference clock input is capable of HSTL, eHSTL, LVEPECL, 1.8V or 2.5V LVTTTL operation independent of the device output. (See Input/Output Selection table.)

## POWER SUPPLY CHARACTERISTICS FOR eHSTL OUTPUTS<sup>(1)</sup>

Symbol	Parameter	Test Conditions <sup>(2)</sup>	Typ.	Max	Unit
I <sub>DDQ</sub>	Quiescent V <sub>DD</sub> Power Supply Current <sup>(3)</sup>	V <sub>DDQ</sub> = Max., REF = LOW, $\overline{PD}$ = HIGH, $\overline{nSOE}$ = LOW, $\overline{PLL\_EN}$ = HIGH, DS <sub>[1:0]</sub> = MM, nF <sub>[2:0]</sub> = LHH, FBF <sub>[2:0]</sub> = LHH, Outputs enabled, All outputs unloaded	100	150	mA
I <sub>DDQQ</sub>	Quiescent V <sub>DDQ</sub> Power Supply Current <sup>(3)</sup>	V <sub>DDQ</sub> = Max., REF = LOW, $\overline{PD}$ = HIGH, $\overline{nSOE}$ = LOW, $\overline{PLL\_EN}$ = HIGH, DS <sub>[1:0]</sub> = MM, nF <sub>[2:0]</sub> = LHH, FBF <sub>[2:0]</sub> = LHH, Outputs enabled, All outputs unloaded	1.8	50	μA
I <sub>DDPD</sub>	Power Down Current	V <sub>DD</sub> = Max., $\overline{PD}$ = LOW, $\overline{nSOE}$ = LOW, $\overline{PLL\_EN}$ = HIGH	1.7	5	mA
I <sub>DDD</sub>	Dynamic V <sub>DD</sub> Power Supply Current per Output	V <sub>DD</sub> = Max., V <sub>DDQ</sub> = Max., C <sub>L</sub> = 0pF	19	30	μA/MHz
I <sub>DDQD</sub>	Dynamic V <sub>DDQ</sub> Power Supply Current per Output	V <sub>DD</sub> = Max., V <sub>DDQ</sub> = Max., C <sub>L</sub> = 0pF	17	30	μA/MHz
I <sub>TOT</sub>	Total Power V <sub>DD</sub> Supply Current <sup>(4)</sup>	V <sub>DDQ</sub> = 1.8V, F <sub>VCO</sub> = 100MHz, C <sub>L</sub> = 15pF	115	170	mA
		V <sub>DDQ</sub> = 1.8V, F <sub>VCO</sub> = 250MHz, C <sub>L</sub> = 15pF	150	225	
I <sub>TOTQ</sub>	Total Power V <sub>DDQ</sub> Supply Current <sup>(4)</sup>	V <sub>DDQ</sub> = 1.8V, F <sub>VCO</sub> = 100MHz, C <sub>L</sub> = 15pF	45	70	mA
		V <sub>DDQ</sub> = 1.8V, F <sub>VCO</sub> = 250MHz, C <sub>L</sub> = 15pF	100	150	

### NOTES:

1. These power consumption characteristics are for all the valid input interfaces and cover the worst case input and output interface combinations.
2. The termination resistors are excluded from these measurements.
3. If the differential input interface is used, the true input is held LOW and the complementary input is held HIGH.
4. FS = HIGH.

## DIFFERENTIAL INPUT AC TEST CONDITIONS FOR eHSTL

Symbol	Parameter	Value	Units
V <sub>DIF</sub>	Input Signal Swing <sup>(1)</sup>	1	V
V <sub>X</sub>	Differential Input Signal Crossing Point <sup>(2)</sup>	900	mV
V <sub>THI</sub>	Input Timing Measurement Reference Level <sup>(3)</sup>	Crossing Point	V
t <sub>R</sub> , t <sub>F</sub>	Input Signal Edge Rate <sup>(4)</sup>	1	V/ns

### NOTES:

1. The 1V peak-to-peak input pulse level is specified to allow consistent, repeatable results in an automatic test equipment (ATE) environment. This device meets the V<sub>DIF</sub> (AC) specification under actual use conditions.
2. A 900mV crossing point level is specified to allow consistent, repeatable results in an automatic test equipment (ATE) environment. This device meets the V<sub>X</sub> specification under actual use conditions.
3. In all cases, input waveform timing is marked at the differential cross-point of the input signals.
4. The input signal edge rate of 1V/ns or greater is to be maintained in the 20% to 80% range of the input waveform.

## DC ELECTRICAL CHARACTERISTICS OVER OPERATING RANGE FOR LVEPECL<sup>(1)</sup>

Symbol	Parameter	Test Conditions	Min.	Typ. <sup>(2)</sup>	Max	Unit
<b>Input Characteristics</b>						
I <sub>IH</sub>	Input HIGH Current	V <sub>DD</sub> = 2.7V V <sub>I</sub> = V <sub>DDQ</sub> /GND	—	—	±5	μA
I <sub>IL</sub>	Input LOW Current	V <sub>DD</sub> = 2.7V V <sub>I</sub> = GND/V <sub>DDQ</sub>	—	—	±5	
V <sub>IK</sub>	Clamp Diode Voltage	V <sub>DD</sub> = 2.3V, I <sub>IN</sub> = -18mA	—	-0.7	-1.2	V
V <sub>IN</sub>	DC Input Voltage		-0.3	—	3.6	V
V <sub>CM</sub>	DC Common Mode Input Voltage <sup>(3,5)</sup>		915	1082	1248	mV
V <sub>REF</sub>	Single-Ended Reference Voltage <sup>(4,5)</sup>		—	1082	—	mV
V <sub>IH</sub>	DC Input HIGH		1275	—	1620	mV
V <sub>IL</sub>	DC Input LOW		555	—	875	mV

**NOTES:**

- See RECOMMENDED OPERATING RANGE table.
- Typical values are at V<sub>DD</sub> = 2.5V, +25°C ambient.
- V<sub>CM</sub> specifies the maximum allowable range of (V<sub>TR</sub> + V<sub>CP</sub>) /2. Differential mode only.
- For single-ended operation while in differential mode, REF<sub>[1:0]</sub>/VREF<sub>[1:0]</sub> is tied to the DC voltage VREF<sub>[1:0]</sub>.
- The reference clock input is capable of HSTL, eHSTL, LVEPECL, 1.8V or 2.5V LVTTTL operation independent of the device output. (See Input/Output Selection table.)

## DIFFERENTIAL INPUT AC TEST CONDITIONS FOR LVEPECL

Symbol	Parameter	Value	Units
V <sub>DIF</sub>	Input Signal Swing <sup>(1)</sup>	732	mV
V <sub>X</sub>	Differential Input Signal Crossing Point <sup>(2)</sup>	1082	mV
V <sub>THI</sub>	Input Timing Measurement Reference Level <sup>(3)</sup>	Crossing Point	V
t <sub>R</sub> , t <sub>F</sub>	Input Signal Edge Rate <sup>(4)</sup>	1	V/ns

**NOTES:**

- The 732mV peak-to-peak input pulse level is specified to allow consistent, repeatable results in an automatic test equipment (ATE) environment. This device meets the V<sub>DIF</sub> (AC) specification under actual use conditions.
- A 1082mV crossing point level is specified to allow consistent, repeatable results in an automatic test equipment (ATE) environment. This device meets the V<sub>X</sub> specification under actual use conditions.
- In all cases, input waveform timing is marked at the differential cross-point of the input signals.
- The input signal edge rate of 1V/ns or greater is to be maintained in the 20% to 80% range of the input waveform.

## DC ELECTRICAL CHARACTERISTICS OVER OPERATING RANGE FOR 2.5V LVTTTL<sup>(1)</sup>

Symbol	Parameter	Test Conditions	Min.	Typ. <sup>(8)</sup>	Max	Unit
<b>Input Characteristics</b>						
I <sub>IH</sub>	Input HIGH Current	V <sub>DD</sub> = 2.7V      V <sub>I</sub> = V <sub>DDQ</sub> /GND	—	—	±5	μA
I <sub>IL</sub>	Input LOW Current	V <sub>DD</sub> = 2.7V      V <sub>I</sub> = GND/V <sub>DDQ</sub>	—	—	±5	μA
V <sub>IK</sub>	Clamp Diode Voltage	V <sub>DD</sub> = 2.3V, I <sub>IN</sub> = -18mA	—	-0.7	-1.2	V
V <sub>IN</sub>	DC Input Voltage		-0.3		+3.6	V
<b>Single-Ended Inputs<sup>(2)</sup></b>						
V <sub>IH</sub>	DC Input HIGH		1.7		—	V
V <sub>IL</sub>	DC Input LOW		—		0.7	V
<b>Differential Inputs</b>						
V <sub>DIF</sub>	DC Differential Voltage <sup>(3,9)</sup>		0.2		—	V
V <sub>CM</sub>	DC Common Mode Input Voltage <sup>(4,9)</sup>		1150	1250	1350	mV
V <sub>IH</sub>	DC Input HIGH <sup>(5,6,9)</sup>		V <sub>REF</sub> + 100		—	mV
V <sub>IL</sub>	DC Input LOW <sup>(5,7,9)</sup>		—		V <sub>REF</sub> - 100	mV
V <sub>REF</sub>	Single-Ended Reference Voltage <sup>(5,9)</sup>		—	1250	—	mV
<b>Output Characteristics</b>						
V <sub>OH</sub>	Output HIGH Voltage	I <sub>OH</sub> = -12mA	V <sub>DDQ</sub> - 0.4		—	V
		I <sub>OH</sub> = -100μA	V <sub>DDQ</sub> - 0.1		—	V
V <sub>OL</sub>	Output LOW Voltage	I <sub>OL</sub> = 12mA	—		0.4	V
		I <sub>OL</sub> = 100μA	—		0.1	V

**NOTES:**

- See RECOMMENDED OPERATING RANGE table.
- For 2.5V LVTTTL single-ended operation, the RxS pin is tied HIGH and  $\overline{\text{REF}}_{[1:0]}/\text{V}_{\text{REF}[1:0]}$  is left floating. If TxS is HIGH,  $\overline{\text{FB}}/\text{V}_{\text{REF}2}$  should be left floating.
- V<sub>DIF</sub> specifies the minimum input differential voltage (V<sub>TR</sub> - V<sub>CP</sub>) required for switching where V<sub>TR</sub> is the "true" input level and V<sub>CP</sub> is the "complement" input level. Differential mode only. The DC differential voltage must be maintained to guarantee retaining the existing HIGH or LOW input. The AC differential voltage must be achieved to guarantee switching to a new state.
- V<sub>CM</sub> specifies the maximum allowable range of (V<sub>TR</sub> + V<sub>CP</sub>) / 2. Differential mode only.
- For single-ended operation, in differential mode,  $\overline{\text{REF}}_{[1:0]}/\text{V}_{\text{REF}[1:0]}$  is tied to the DC voltage V<sub>REF[1:0]</sub>.
- Voltage required to maintain a logic HIGH, single-ended operation in differential mode.
- Voltage required to maintain a logic LOW, single-ended operation in differential mode.
- Typical values are at V<sub>DD</sub> = 2.5V, V<sub>DDQ</sub> = V<sub>DD</sub>, +25°C ambient.
- The reference clock input is capable of HSTL, eHSTL, LVEPECL, 1.8V or 2.5V LVTTTL operation independent of the device output. (See Input/Output Selection table.)

## POWER SUPPLY CHARACTERISTICS FOR 2.5V LVTTTL OUTPUTS<sup>(1)</sup>

Symbol	Parameter	Test Conditions <sup>(2)</sup>	Typ.	Max	Unit
I <sub>DDQ</sub>	Quiescent V <sub>DD</sub> Power Supply Current <sup>(3)</sup>	V <sub>DDQ</sub> = Max., REF = LOW, $\overline{PD}$ = HIGH, $\overline{nSOE}$ = LOW, $\overline{PLL\_EN}$ = HIGH, DS <sub>[1:0]</sub> = MM, nF <sub>[2:0]</sub> = LHH, FBF <sub>[2:0]</sub> = LHH, Outputs enabled, All outputs unloaded	100	150	mA
I <sub>DDQQ</sub>	Quiescent V <sub>DDQ</sub> Power Supply Current <sup>(3)</sup>	V <sub>DDQ</sub> = Max., REF = LOW, $\overline{PD}$ = HIGH, $\overline{nSOE}$ = LOW, $\overline{PLL\_EN}$ = HIGH, DS <sub>[1:0]</sub> = MM, nF <sub>[2:0]</sub> = LHH, FBF <sub>[2:0]</sub> = LHH, Outputs enabled, All outputs unloaded	13	50	μA
I <sub>DDPD</sub>	Power Down Current	V <sub>DD</sub> = Max., $\overline{PD}$ = LOW, $\overline{nSOE}$ = LOW, $\overline{PLL\_EN}$ = HIGH	1.7	5	mA
I <sub>DDD</sub>	Dynamic V <sub>DD</sub> Power Supply Current per Output	V <sub>DD</sub> = Max., V <sub>DDQ</sub> = Max., C <sub>L</sub> = 0pF	21	30	μA/MHz
I <sub>DDQD</sub>	Dynamic V <sub>DDQ</sub> Power Supply Current per Output	V <sub>DD</sub> = Max., V <sub>DDQ</sub> = Max., C <sub>L</sub> = 0pF	31	40	μA/MHz
I <sub>TOT</sub>	Total Power V <sub>DD</sub> Supply Current <sup>(4)</sup>	V <sub>DDQ</sub> = 2.5V., F <sub>VCO</sub> = 100MHz, C <sub>L</sub> = 15pF	115	170	mA
		V <sub>DDQ</sub> = 2.5V., F <sub>VCO</sub> = 250MHz, C <sub>L</sub> = 15pF	155	230	
I <sub>TOTQ</sub>	Total Power V <sub>DDQ</sub> Supply Current <sup>(4)</sup>	V <sub>DDQ</sub> = 2.5V., F <sub>VCO</sub> = 100MHz, C <sub>L</sub> = 15pF	80	120	mA
		V <sub>DDQ</sub> = 2.5V., F <sub>VCO</sub> = 250MHz, C <sub>L</sub> = 15pF	250	375	

### NOTES:

1. These power consumption characteristics are for all the valid input interfaces and cover the worst case input and output interface combinations.
2. The termination resistors are excluded from these measurements.
3. If the differential input interface is used, the true input is held LOW and the complementary input is held HIGH.
4. FS = HIGH.

## DIFFERENTIAL INPUT AC TEST CONDITIONS FOR 2.5V LVTTTL

Symbol	Parameter	Value	Units
V <sub>DIF</sub>	Input Signal Swing <sup>(1)</sup>	V <sub>DD</sub>	V
V <sub>X</sub>	Differential Input Signal Crossing Point <sup>(2)</sup>	V <sub>DD</sub> /2	V
V <sub>THI</sub>	Input Timing Measurement Reference Level <sup>(3)</sup>	Crossing Point	V
t <sub>R</sub> , t <sub>F</sub>	Input Signal Edge Rate <sup>(4)</sup>	2.5	V/ns

### NOTES:

1. A nominal 2.5V peak-to-peak input pulse level is specified to allow consistent, repeatable results in an automatic test equipment (ATE) environment. This device meets the V<sub>DIF</sub> (AC) specification under actual use conditions.
2. A nominal 1.25V crossing point level is specified to allow consistent, repeatable results in an automatic test equipment (ATE) environment. This device meets the V<sub>X</sub> specification under actual use conditions.
3. In all cases, input waveform timing is marked at the differential cross-point of the input signals.
4. The input signal edge rate of 2.5V/ns or greater is to be maintained in the 20% to 80% range of the input waveform.

## SINGLE-ENDED INPUT AC TEST CONDITIONS FOR 2.5V LVTTTL

Symbol	Parameter	Value	Units
V <sub>IH</sub>	Input HIGH Voltage	V <sub>DD</sub>	V
V <sub>IL</sub>	Input LOW Voltage	0	V
V <sub>THI</sub>	Input Timing Measurement Reference Level <sup>(1)</sup>	V <sub>DD</sub> /2	V
t <sub>R</sub> , t <sub>F</sub>	Input Signal Edge Rate <sup>(2)</sup>	2	V/ns

### NOTES:

1. A nominal 1.25V timing measurement reference level is specified to allow constant, repeatable results in an automatic test equipment (ATE) environment.
2. The input signal edge rate of 2V/ns or greater is to be maintained in the 10% to 90% range of the input waveform.

## DC ELECTRICAL CHARACTERISTICS OVER OPERATING RANGE FOR 1.8V LVTTTL<sup>(1)</sup>

Symbol	Parameter	Test Conditions	Min.	Typ. <sup>(8)</sup>	Max	Unit
<b>Input Characteristics</b>						
I <sub>IH</sub>	Input HIGH Current	V <sub>DD</sub> = 2.7V      V <sub>I</sub> = V <sub>DDQ</sub> /GND	—	—	±5	μA
I <sub>IL</sub>	Input LOW Current	V <sub>DD</sub> = 2.7V      V <sub>I</sub> = GND/V <sub>DDQ</sub>	—	—	±5	μA
V <sub>IK</sub>	Clamp Diode Voltage	V <sub>DD</sub> = 2.3V, I <sub>IN</sub> = -18mA	—	-0.7	-1.2	V
V <sub>IN</sub>	DC Input Voltage		-0.3		V <sub>DDQ</sub> + 0.3	V
<b>Single-Ended Inputs<sup>(2)</sup></b>						
V <sub>IH</sub>	DC Input HIGH		1.073 <sup>(10)</sup>		—	V
V <sub>IL</sub>	DC Input LOW		—		0.683 <sup>(11)</sup>	V
<b>Differential Inputs</b>						
V <sub>DIF</sub>	DC Differential Voltage <sup>(3,9)</sup>		0.2		—	V
V <sub>CM</sub>	DC Common Mode Input Voltage <sup>(4,9)</sup>		825	900	975	mV
V <sub>IH</sub>	DC Input HIGH <sup>(5,6,9)</sup>		V <sub>REF</sub> + 100		—	mV
V <sub>IL</sub>	DC Input LOW <sup>(5,7,9)</sup>		—		V <sub>REF</sub> - 100	mV
V <sub>REF</sub>	Single-Ended Reference Voltage <sup>(5,9)</sup>		—	900	—	mV
<b>Output Characteristics</b>						
V <sub>OH</sub>	Output HIGH Voltage	I <sub>OH</sub> = -6mA	V <sub>DDQ</sub> - 0.4		—	V
		I <sub>OH</sub> = -100μA	V <sub>DDQ</sub> - 0.1		—	V
V <sub>OL</sub>	Output LOW Voltage	I <sub>OL</sub> = 6mA	—		0.4	V
		I <sub>OL</sub> = 100μA	—		0.1	V

**NOTES:**

- See RECOMMENDED OPERATING RANGE table.
- For 1.8V LVTTTL single-ended operation, the RxS pin is MID and  $\overline{\text{REF}}_{[1:0]}/\text{VREF}_{[1:0]}$  is left floating. If TxS is MID,  $\overline{\text{FB}}/\text{VREF}_2$  should be left floating.
- V<sub>DIF</sub> specifies the minimum input differential voltage (V<sub>TR</sub> - V<sub>CP</sub>) required for switching where V<sub>TR</sub> is the "true" input level and V<sub>CP</sub> is the "complement" input level. Differential mode only. The DC differential voltage must be maintained to guarantee retaining the existing HIGH or LOW input. The AC differential voltage must be achieved to guarantee switching to a new state.
- V<sub>CM</sub> specifies the maximum allowable range of (V<sub>TR</sub> + V<sub>CP</sub>) / 2. Differential mode only.
- For single-ended operation in differential mode,  $\overline{\text{REF}}_{[1:0]}/\text{VREF}_{[1:0]}$  is tied to the DC voltage V<sub>REF[1:0]}</sub>. The input is guaranteed to toggle within ±200mV of V<sub>REF[1:0]}</sub> when V<sub>REF[1:0]}</sub> is constrained within +600mV and V<sub>DDI</sub>-600mV, where V<sub>DDI</sub> is the nominal 1.8V power supply of the device driving the REF<sub>[1:0]</sub> input. To guarantee switching in voltage range specified in the JEDEC 1.8V LVTTTL interface specification, V<sub>REF[1:0]}</sub> must be maintained at 900mV with appropriate tolerances.
- Voltage required to maintain a logic HIGH, single-ended operation in differential mode.
- Voltage required to maintain a logic LOW, single-ended operation in differential mode.
- Typical values are at V<sub>DD</sub> = 2.5V, V<sub>DDQ</sub> = 1.8V, +25°C ambient.
- The reference clock input is capable of HSTL, eHSTL, LVEPECL, 1.8V or 2.5V LVTTTL operation independent of the device output. (See Input/Output Selection table.)
- This value is the worst case minimum V<sub>IH</sub> over the specification range of the 1.8V power supply. The 1.8V LVTTTL specification is V<sub>IH</sub> = 0.65 \* V<sub>DD</sub> where V<sub>DD</sub> is 1.8V ± 0.15V. However, the LVTTTL translator is supplied by a 2.5V nominal supply on this part. To ensure compliance with the specification, the translator was designed to accept the calculated worst case value ( V<sub>IH</sub> = 0.65 \* [1.8 - 0.15V]) rather than reference against a nominal 1.8V supply.
- This value is the worst case maximum V<sub>IL</sub> over the specification range of the 1.8V power supply. The 1.8V LVTTTL specification is V<sub>IL</sub> = 0.35 \* V<sub>DD</sub> where V<sub>DD</sub> is 1.8V ± 0.15V. However, the LVTTTL translator is supplied by a 2.5V nominal supply on this part. To ensure compliance with the specification, the translator was designed to accept the calculated worst case value ( V<sub>IL</sub> = 0.35 \* [1.8 + 0.15V]) rather than reference against a nominal 1.8V supply.

## POWER SUPPLY CHARACTERISTICS FOR 1.8V LVTTTL OUTPUTS<sup>(1)</sup>

Symbol	Parameter	Test Conditions <sup>(2)</sup>	Typ.	Max	Unit
I <sub>DDQ</sub>	Quiescent V <sub>DD</sub> Power Supply Current <sup>(3)</sup>	V <sub>DDQ</sub> = Max., REF = LOW, $\overline{PD}$ = HIGH, $\overline{nSOE}$ = LOW, $\overline{PLL\_EN}$ = HIGH, DS <sub>[1:0]</sub> = MM, nF <sub>[2:0]</sub> = LHH, FBF <sub>[2:0]</sub> = LHH, Outputs enabled, All outputs unloaded	100	150	mA
I <sub>DDQQ</sub>	Quiescent V <sub>DDQ</sub> Power Supply Current <sup>(3)</sup>	V <sub>DDQ</sub> = Max., REF = LOW, $\overline{PD}$ = HIGH, $\overline{nSOE}$ = LOW, $\overline{PLL\_EN}$ = HIGH, DS <sub>[1:0]</sub> = MM, nF <sub>[2:0]</sub> = LHH, FBF <sub>[2:0]</sub> = LHH, Outputs enabled, All outputs unloaded	1.8	50	μA
I <sub>DDPD</sub>	Power Down Current	V <sub>DD</sub> = Max., $\overline{PD}$ = LOW, $\overline{nSOE}$ = LOW, $\overline{PLL\_EN}$ = HIGH	1.7	5	mA
I <sub>DDD</sub>	Dynamic V <sub>DD</sub> Power Supply Current per Output	V <sub>DD</sub> = Max., V <sub>DDQ</sub> = Max., C <sub>L</sub> = 0pF	22	30	μA/MHz
I <sub>DDQD</sub>	Dynamic V <sub>DDQ</sub> Power Supply Current per Output	V <sub>DD</sub> = Max., V <sub>DDQ</sub> = Max., C <sub>L</sub> = 0pF	22	30	μA/MHz
I <sub>TOT</sub>	Total Power V <sub>DD</sub> Supply Current <sup>(4)</sup>	V <sub>DDQ</sub> = 1.8V., F <sub>VCO</sub> = 100MHz, C <sub>L</sub> = 15pF	120	180	mA
		V <sub>DDQ</sub> = 1.8V., F <sub>VCO</sub> = 250MHz, C <sub>L</sub> = 15pF	160	240	
I <sub>TOTQ</sub>	Total Power V <sub>DDQ</sub> Supply Current <sup>(4)</sup>	V <sub>DDQ</sub> = 1.8V., F <sub>VCO</sub> = 100MHz, C <sub>L</sub> = 15pF	55	80	mA
		V <sub>DDQ</sub> = 1.8V., F <sub>VCO</sub> = 250MHz, C <sub>L</sub> = 15pF	170	255	

### NOTES:

1. These power consumption characteristics are for all the valid input interfaces and cover the worst case input and output interface combinations.
2. The termination resistors are excluded from these measurements.
3. If the differential input interface is used, the true input is held LOW and the complementary input is held HIGH.
4. FS = HIGH.

## DIFFERENTIAL INPUT AC TEST CONDITIONS FOR 1.8V LVTTTL

Symbol	Parameter	Value	Units
V <sub>DIF</sub>	Input Signal Swing <sup>(1)</sup>	V <sub>DDI</sub>	V
V <sub>X</sub>	Differential Input Signal Crossing Point <sup>(2)</sup>	V <sub>DDI</sub> /2	mV
V <sub>THI</sub>	Input Timing Measurement Reference Level <sup>(3)</sup>	Crossing Point	V
t <sub>R</sub> , t <sub>F</sub>	Input Signal Edge Rate <sup>(4)</sup>	1.8	V/ns

### NOTES:

1. V<sub>DDI</sub> is the nominal 1.8V supply (1.8V ± 0.15V) of the part or source driving the input. A nominal 1.8V peak-to-peak input pulse level is specified to allow consistent, repeatable results in an automatic test equipment (ATE) environment. This device meets the V<sub>DIF</sub> (AC) specification under actual use conditions.
2. A nominal 900mV crossing point level is specified to allow consistent, repeatable results in an automatic test equipment (ATE) environment. This device meets the V<sub>X</sub> specification under actual use conditions.
3. In all cases, input waveform timing is marked at the differential cross-point of the input signals.
4. The input signal edge rate of 1.8V/ns or greater is to be maintained in the 20% to 80% range of the input waveform.

## SINGLE-ENDED INPUT AC TEST CONDITIONS FOR 1.8V LVTTTL

Symbol	Parameter	Value	Units
V <sub>IH</sub>	Input HIGH Voltage <sup>(1)</sup>	V <sub>DDI</sub>	V
V <sub>IL</sub>	Input LOW Voltage	0	V
V <sub>THI</sub>	Input Timing Measurement Reference Level <sup>(2)</sup>	V <sub>DDI</sub> /2	mV
t <sub>R</sub> , t <sub>F</sub>	Input Signal Edge Rate <sup>(3)</sup>	2	V/ns

### NOTES:

1. V<sub>DDI</sub> is the nominal 1.8V supply (1.8V ± 0.15V) of the part or source driving the input.
2. A nominal 900mV timing measurement reference level is specified to allow constant, repeatable results in an automatic test equipment (ATE) environment.
3. The input signal edge rate of 2V/ns or greater is to be maintained in the 10% to 90% range of the input waveform.

## AC ELECTRICAL CHARACTERISTICS OVER OPERATING RANGE

Symbol	Parameter	Min.	Typ.	Max	Unit	
F <sub>NOM</sub>	VCO Frequency Range	see Programmable Skew Range and Resolution Table				
t <sub>RPW</sub>	Reference Clock Pulse Width HIGH or LOW	1	—	—	ns	
t <sub>FPW</sub>	Feedback Input Pulse Width HIGH or LOW	1	—	—	ns	
t <sub>u</sub>	Programmable Skew Time Unit	see Control Summary Table				
t <sub>sk(B)</sub>	Output Matched Pair Skew <sup>(1,2,4)</sup>	—	—	50	ps	
t <sub>sk(O)</sub>	Output Skew (Rise-Rise, Fall-Fall, Nominal) <sup>(1,3)</sup>	—	—	100	ps	
t <sub>sk1(ω)</sub>	Multiple Frequency Skew (Rise-Rise, Fall-Fall, Nominal-Divided, Divided-Divided) <sup>(1,3,4)</sup>	—	—	100	ps	
t <sub>sk2(ω)</sub>	Multiple Frequency Skew (Rise-Fall, Nominal-Divided, Divided-Divided) <sup>(1,3,4)</sup>	—	—	400	ps	
t <sub>sk1(INV)</sub>	Inverting Skew (Nominal-Inverted) <sup>(1,3)</sup>	—	—	400	ps	
t <sub>sk2(INV)</sub>	Inverting Skew (Rise-Rise, Fall-Fall, Rise-Fall, Inverted-Divided) <sup>(1,3,4)</sup>	—	—	400	ps	
t <sub>sk(PR)</sub>	Process Skew <sup>(1,3,5)</sup>	—	—	300	ps	
t(φ)	REF Input to FB Static Phase Offset <sup>(6)</sup>	-100	—	100	ps	
t <sub>ODCV</sub>	Output Duty Cycle Variation from 50% <sup>(7)</sup>	HSTL, eHSTL, 1.8V LVTTTL	-375	—	375	ps
		2.5VLVTTL	-275	—	275	
t <sub>ORISE</sub>	Output Rise Time <sup>(8)</sup>	HSTL, eHSTL, 1.8V LVTTTL	—	—	1.2	ns
		2.5VLVTTL	—	—	1	
t <sub>OFALL</sub>	Output Fall Time <sup>(8)</sup>	HSTL, eHSTL, 1.8V LVTTTL	—	—	1.2	ns
		2.5VLVTTL	—	—	1	
t <sub>L</sub>	Power-up PLL Lock Time <sup>(9)</sup>	—	—	1	ms	
t <sub>L(ω)</sub>	PLL Lock Time After Input Frequency Change <sup>(9)</sup>	—	—	1	ms	
t <sub>L(REFSEL1)</sub>	PLL Lock Time After Change in REF_SEL <sup>(9,11)</sup>	—	—	100	μs	
t <sub>L(REFSEL2)</sub>	PLL Lock Time After Change in REF_SEL (REF <sub>1</sub> and REF <sub>0</sub> are different frequency) <sup>(9)</sup>	—	—	1	ms	
t <sub>L(PD)</sub>	PLL Lock Time After Asserting $\overline{PD}$ Pin <sup>(9)</sup>	—	—	1	ms	
t <sub>JIT(CC)</sub>	Cycle-to-Cycle Output Jitter (peak-to-peak) <sup>(10)</sup>	—	50	75	ps	
t <sub>JIT(PER)</sub>	Period Jitter (peak-to-peak) <sup>(10)</sup>	—	—	75	ps	
t <sub>JIT(HP)</sub>	Half Period Jitter (peak-to-peak, QFB/QFB) <sup>(10,12)</sup>	—	—	125	ps	
t <sub>JIT(DUTY)</sub>	Duty Cycle Jitter (peak-to-peak)	—	—	100	ps	
V <sub>OX</sub>	HSTL and eHSTL Differential True and Complementary Output Crossing Voltage Level, QFB/QFB only <sup>(12)</sup>	V <sub>DDQ</sub> /2 - 150	V <sub>DDQ</sub> /2	V <sub>DDQ</sub> /2 + 150	mV	

### NOTES:

- Skew is the time between the earliest and latest output transition among all outputs for which the same t<sub>u</sub> delay has been selected, and when all outputs are loaded with the specified load.
- t<sub>sk(B)</sub> is the skew between a pair of outputs (nQ0 and nQ1) when all outputs are selected as the same class.
- The measurement is made at V<sub>DDQ</sub>/2.
- There are three classes of outputs: nominal (multiple of t<sub>u</sub> delay), inverted, and divided (divide-by-2 or divide-by-4 mode).
- t<sub>sk(PR)</sub> is the output to corresponding output skew between any two devices operating under the same conditions (V<sub>DD</sub> and V<sub>DDQ</sub>, ambient temperature, air flow, etc.).
- t(φ) is measured with REF and FB the same type of input, the same rise and fall times. For TxS/RxS = MID or HIGH, the measurement is taken from V<sub>TH1</sub> on REF to V<sub>TH1</sub> on FB. For TxS/RxS = LOW, the measurement is taken from the crosspoint of REF/REF to the crosspoint of FB/FB. All outputs are set to 0t<sub>u</sub>, FB input divider set to divide-by-one, and FS = HIGH.
- t<sub>ODCV</sub> is measured with all outputs selected for 0t<sub>u</sub>.
- Output rise and fall times are measured between 20% to 80% of the actual output voltage swing.
- t<sub>L</sub>, t<sub>L(ω)</sub>, t<sub>L(REFSEL1)</sub>, t<sub>L(REFSEL2)</sub>, and t<sub>L(PD)</sub> are the times that are required before the synchronization is achieved. These specifications are valid only after V<sub>DD</sub>/V<sub>DDQ</sub> is stable and within the normal operating limits. These parameters are measured from the application of a new signal at REF or FB, or after PD is (re)asserted until t(φ) is within specified limits.
- The jitter parameters are measured with all outputs selected for 0t<sub>u</sub>, FB input divider is set to divide-by-one, and FS = HIGH.
- Both REF inputs must be the same frequency, but up to ±180° out of phase.
- For HSTL/eHSTL outputs only.

## AC DIFFERENTIAL INPUT SPECIFICATIONS<sup>(1)</sup>

Symbol	Parameter	Min.	Typ.	Max	Unit
t <sub>w</sub>	Reference/Feedback Input Clock Pulse Width HIGH or LOW (HSTL/eHSTL outputs) <sup>(2)</sup>	1	—	—	ns
	Reference/Feedback Input Clock Pulse Width HIGH or LOW (2.5V / 1.8V LVTTTL outputs) <sup>(2)</sup>	1	—	—	

### HSTL/eHSTL/1.8V LVTTTL/2.5V LVTTTL

V <sub>DIF</sub>	AC Differential Voltage <sup>(3)</sup>	400	—	—	mV
V <sub>IH</sub>	AC Input HIGH <sup>(4,5)</sup>	V <sub>x</sub> + 200	—	—	mV
V <sub>IL</sub>	AC Input LOW <sup>(4,6)</sup>	—	—	V <sub>x</sub> - 200	mV

### LVEPECL

V <sub>DIF</sub>	AC Differential Voltage <sup>(3)</sup>	400	—	—	mV
V <sub>IH</sub>	AC Input HIGH <sup>(4)</sup>	1275	—	—	mV
V <sub>IL</sub>	AC Input LOW <sup>(4)</sup>	—	—	875	mV

#### NOTES:

- For differential input mode, RxS is tied to GND.
- Both differential input signals should not be driven to the same level simultaneously. The input will not change state until the inputs have crossed and the voltage range defined by V<sub>DIF</sub> has been met or exceeded.
- Differential mode only. V<sub>DIF</sub> specifies the minimum input voltage (V<sub>TR</sub> - V<sub>CP</sub>) required for switching where V<sub>TR</sub> is the "true" input level and V<sub>CP</sub> is the "complement" input level. The AC differential voltage must be achieved to guarantee switching to a new state.
- For single-ended operation,  $\overline{REF}_{[1:0]}/V_{REF[1:0]}$  is tied to the DC voltage V<sub>REF[1:0]}</sub>. Refer to each input interface's DC specification for the correct V<sub>REF[1:0]}</sub> range.
- Voltage required to switch to a logic HIGH, single-ended operation only.
- Voltage required to switch to a logic LOW, single-ended operation only.

## AC TIMING DIAGRAM

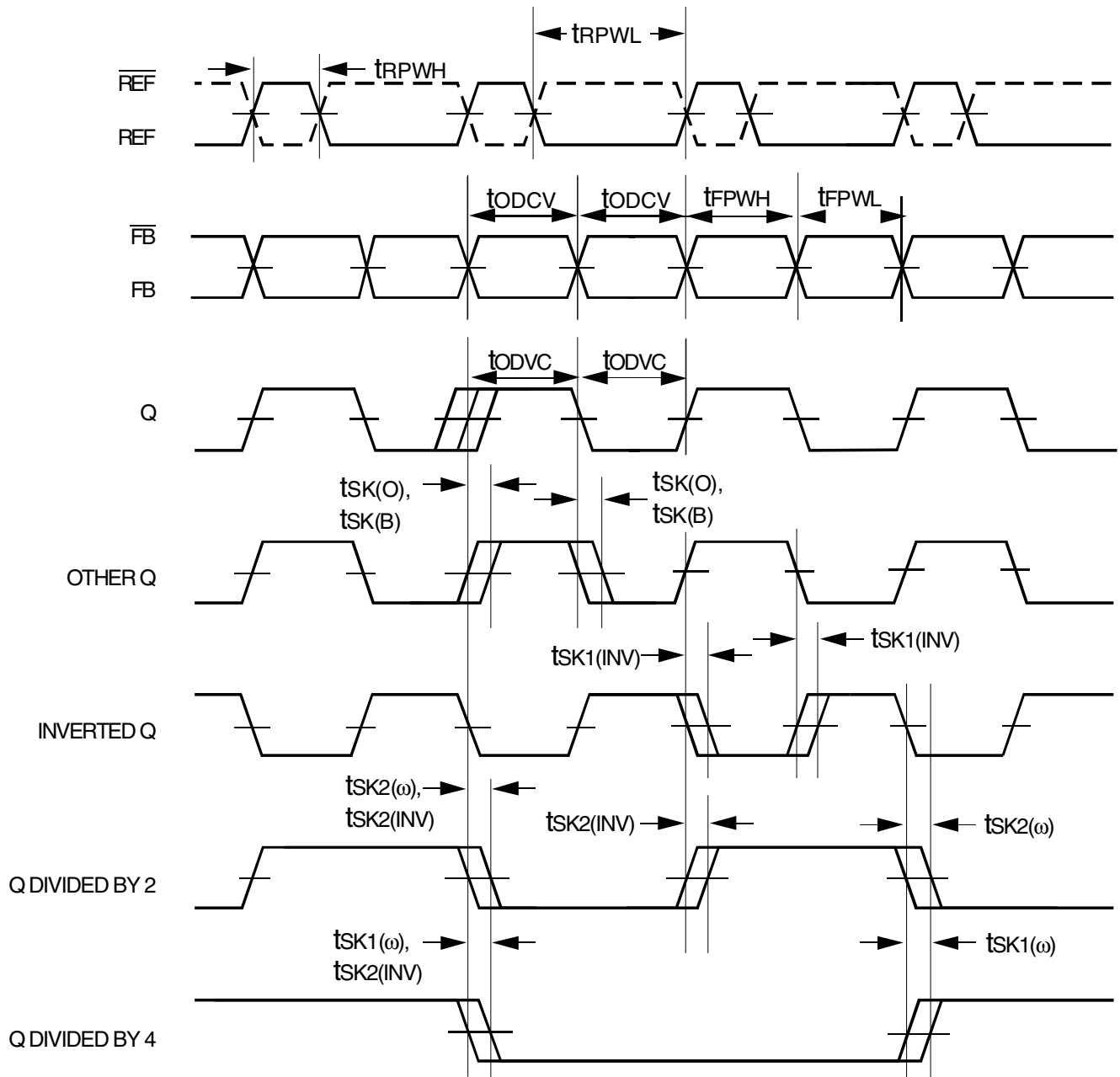

**NOTE:**

1. The AC TIMING DIAGRAM applies to PE = V<sub>DD</sub>. For PE = GND, the negative edge of FB aligns with the negative edge of REF<sub>[1:0]</sub>, divided outputs change on the negative edge of REF<sub>[1:0]</sub>, and the positive edges of the divide-by-2 and divide-by-4 signals align.

## JITTER AND OFFSET TIMING WAVEFORMS

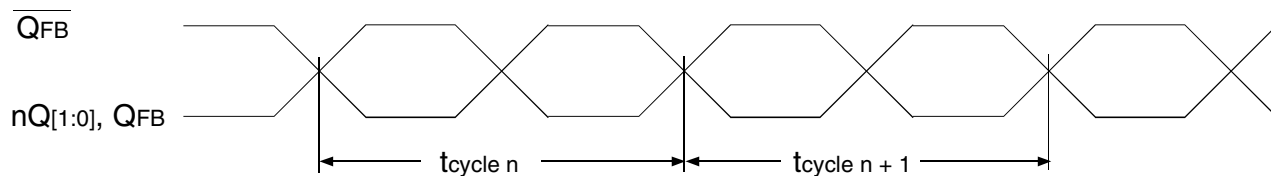

$$t_{\text{jit(cc)}} = |t_{\text{cycle } n} - t_{\text{cycle } n+1}|$$

*Cycle-to-Cycle jitter*

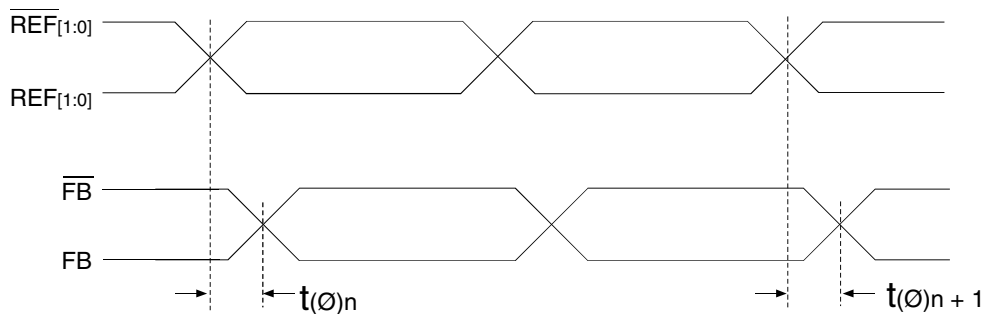

$$t(\emptyset) = \frac{\sum_{n=1}^N t(\emptyset)_n}{N}$$

(N is a large number of samples)

**NOTE:**

1. Diagram for PE = H and TxS/RxS = L.

*Static Phase Offset*

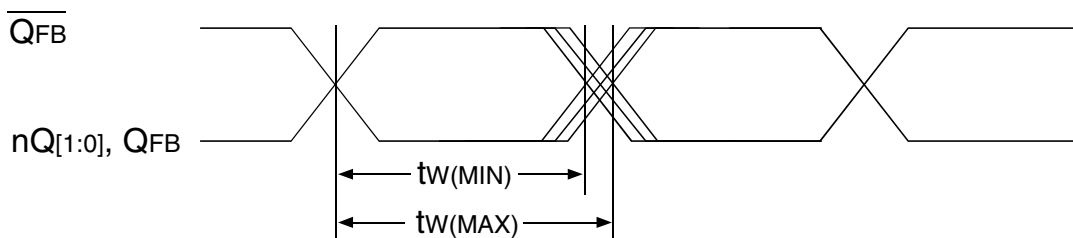

$$t_{\text{JIT(DUTY)}} = |t_{w(\text{MAX})} - t_{w(\text{MIN})}|$$

*Duty-Cycle Jitter*

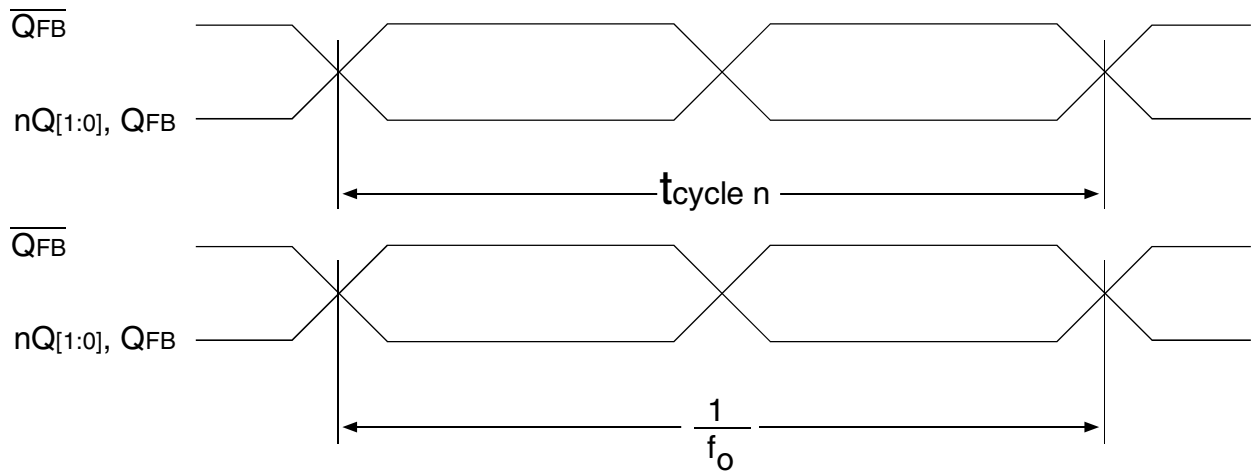

$$t_{jit(per)} = \left| t_{cycle\ n} - \frac{1}{f_0} \right|$$

**Period jitter**

**NOTE:**  
1.  $1/f_0$  = average period.

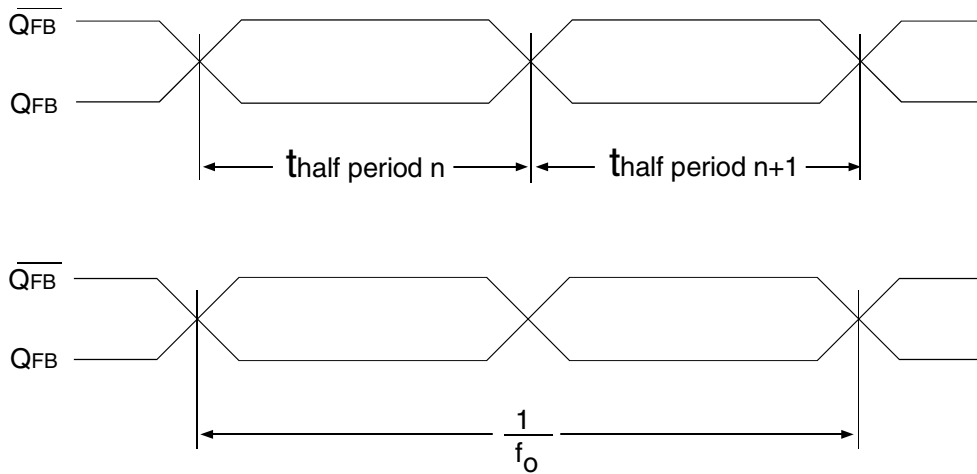

$$t_{jit(hper)} = \left| t_{half\ period\ n} - \frac{1}{2 \cdot f_0} \right|$$

**Half-Period jitter**

**NOTE:**  
1.  $1/f_0$  = average period.

## TEST CIRCUITS AND CONDITIONS

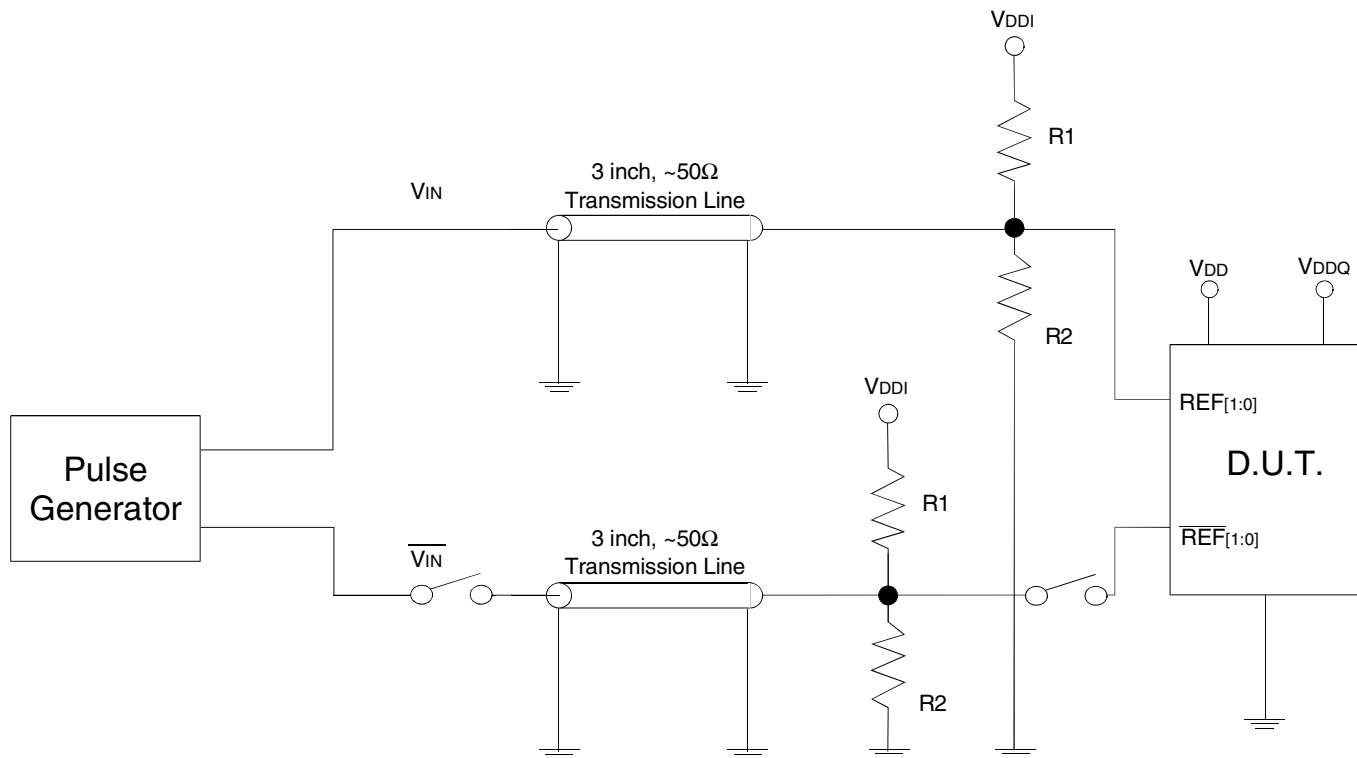

*Test Circuit for Differential Input<sup>(1)</sup>*

### DIFFERENTIAL INPUT TEST CONDITIONS

Symbol	$V_{DD} = 2.5V \pm 0.2V$	Unit
R1	100	$\Omega$
R2	100	$\Omega$
$V_{DDI}$	$V_{CM} * 2$	V
$V_{THI}$	HSTL: Crossing of REF[1:0] and $\overline{REF}$ [1:0] eHSTL: Crossing of REF[1:0] and $\overline{REF}$ [1:0] LVEPECL: Crossing of REF[1:0] and $\overline{REF}$ [1:0] 1.8V LVTTTL: $V_{DDI}/2$ 2.5V LVTTTL: $V_{DD}/2$	V

**NOTE:**

1. This input configuration is used for all input interfaces. For single-ended testing, the  $\overline{REF}$ [1:0] must be left floating. For testing single-ended in differential input mode, the  $\overline{V_{IN}}$  should be floating.

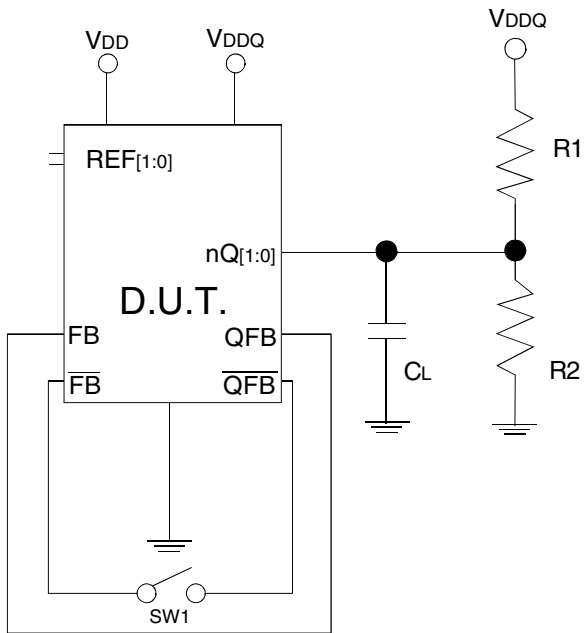

Test Circuit for Outputs

**OUTPUT TEST CONDITIONS**

Symbol	$V_{DD} = 2.5V \pm 0.2V$ $V_{DDQ} = \text{Interface Specified}$	Unit
$C_L$	15	pF
R1	100	$\Omega$
R2	100	$\Omega$
$V_{THO}$	$V_{DDQ} / 2$	V
SW1	TxS = MID or HIGH	Open
	TxS = LOW	Closed

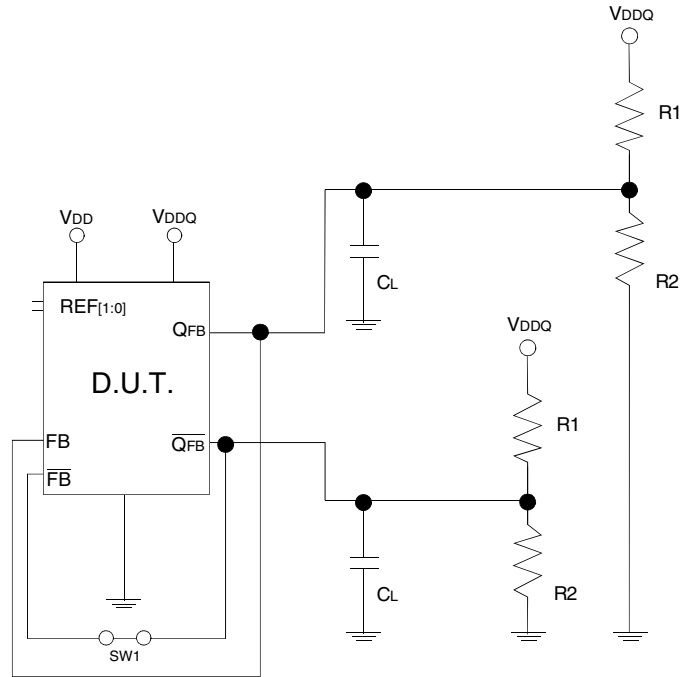

Test Circuit for Differential Feedback

**DIFFERENTIAL FEEDBACK TEST CONDITIONS**

Symbol	$V_{DD} = 2.5V \pm 0.2V$ $V_{DDQ} = \text{Interface Specified}$	Unit
$C_L$	15	pF
R1	100	$\Omega$
R2	100	$\Omega$
$V_{ox}$	HSTL: Crossing of QFB and $\overline{QFB}$ eHSTL: Crossing of QFB and $\overline{QFB}$	V
$V_{THO}$	1.8V LVTTTL: $V_{DDQ}/2$ 2.5V LVTTTL: $V_{DDQ}/2$	V
SW1	TxS = MID or HIGH	Open
	TxS = LOW	Closed

## ORDERING INFORMATION

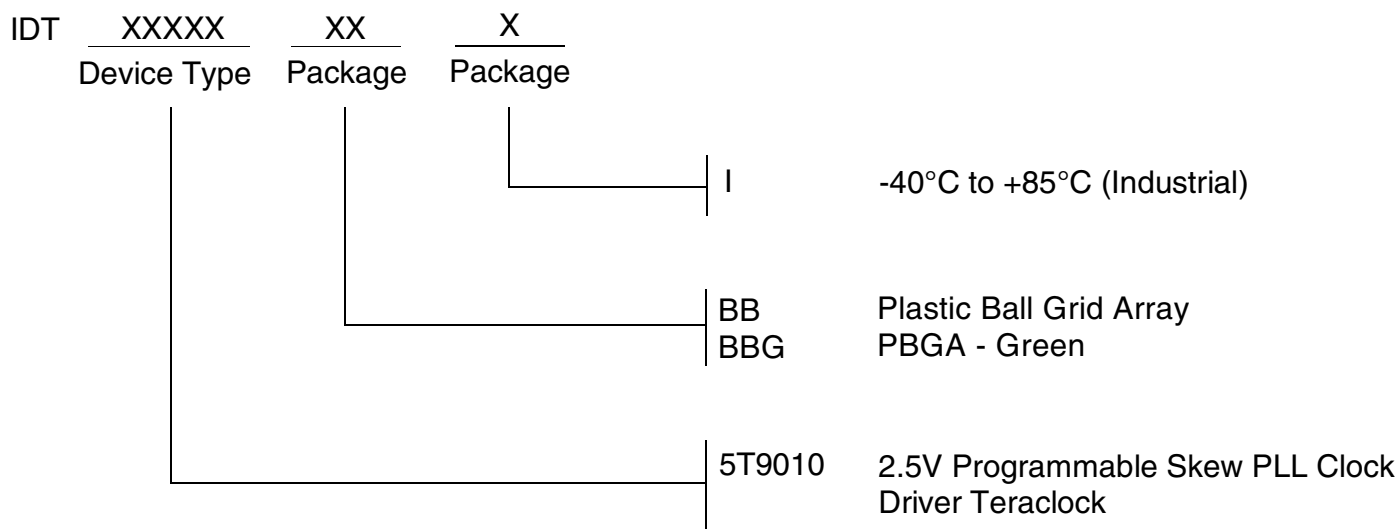

**CORPORATE HEADQUARTERS**  
6024 Silver Creek Valley Road  
San Jose, CA 95138

**for SALES:**  
800-345-7015 or 408-284-8200  
fax: 408-284-2775  
www.idt.com

**for Tech Support:**  
clockhelp@idt.com