



SYNCHRONOUS ETHERNET

WAN PLL

IDT82V3352

Version 3
March 23, 2009

6024 Silver Creek Valley Road, San Jose, CA 95138
Telephone: (800) 345-7015 • TWX: 910-338-2070 • FAX: (408) 284-2775
Printed in U.S.A.
© 2008 Integrated Device Technology, Inc.

DISCLAIMER

Integrated Device Technology, Inc. reserves the right to make changes to its products or specifications at any time, without notice, in order to improve design or performance and to supply the best possible product. IDT does not assume any responsibility for use of any circuitry described other than the circuitry embodied in an IDT product. The Company makes no representations that circuitry described herein is free from patent infringement or other rights of third parties which may result from its use. No license is granted by implication or otherwise under any patent, patent rights or other rights, of Integrated Device Technology, Inc.

LIFE SUPPORT POLICY

Integrated Device Technology's products are not authorized for use as critical components in life support devices or systems unless a specific written agreement pertaining to such intended use is executed between the manufacturer and an officer of IDT.

1. Life support devices or systems are devices or systems which (a) are intended for surgical implant into the body or (b) support or sustain life and whose failure to perform, when properly used in accordance with instructions for use provided in the labeling, can be reasonably expected to result in a significant injury to the user.
 2. A critical component is any components of a life support device or system whose failure to perform can be reasonably expected to cause the failure of the life support device or system, or to affect its safety or effectiveness.
-



Table of Contents

FEATURES	7
HIGHLIGHTS.....	7
MAIN FEATURES	7
OTHER FEATURES.....	7
APPLICATIONS	7
DESCRIPTION	8
FUNCTIONAL BLOCK DIAGRAM	9
1 PIN ASSIGNMENT	10
2 PIN DESCRIPTION	11
3 FUNCTIONAL DESCRIPTION	15
3.1 RESET	15
3.2 MASTER CLOCK	15
3.3 INPUT CLOCKS & FRAME SYNC SIGNALS	16
3.3.1 Input Clocks	16
3.3.2 Frame SYNC Input Signals	16
3.4 INPUT CLOCK PRE-DIVIDER	17
3.5 INPUT CLOCK QUALITY MONITORING	18
3.5.1 Activity Monitoring	18
3.5.2 Frequency Monitoring	19
3.6 DPLL INPUT CLOCK SELECTION	20
3.6.1 External Fast Selection	20
3.6.2 Forced Selection	21
3.6.3 Automatic Selection	21
3.7 SELECTED INPUT CLOCK MONITORING	22
3.7.1 DPLL Locking Detection	22
3.7.1.1 Fast Loss	22
3.7.1.2 Coarse Phase Loss	22
3.7.1.3 Fine Phase Loss	22
3.7.1.4 Hard Limit Exceeding	22
3.7.2 Locking Status	22
3.7.3 Phase Lock Alarm	22
3.8 SELECTED INPUT CLOCK SWITCH	24
3.8.1 Input Clock Validity	24
3.8.2 Selected Input Clock Switch	24
3.8.2.1 Revertive Switch	24
3.8.2.2 Non-Revertive Switch	24
3.8.3 Selected / Qualified Input Clocks Indication	24
3.9 SELECTED INPUT CLOCK STATUS VS. DPLL OPERATING MODE	26
3.9.1 T0 Selected Input Clock vs. DPLL Operating Mode	26
3.10 DPLL OPERATING MODE	28
3.10.1 T0 DPLL Operating Mode	28
3.10.1.1 Free-Run Mode	28
3.10.1.2 Pre-Locked Mode	28
3.10.1.3 Locked Mode	28
3.10.1.3.1 Temp-Holdover Mode	28
3.10.1.4 Lost-Phase Mode	28
3.10.1.5 Holdover Mode	28

3.10.1.5.1	Automatic Instantaneous	29
3.10.1.5.2	Automatic Slow Averaged	29
3.10.1.5.3	Automatic Fast Averaged	29
3.10.1.5.4	Manual	29
3.10.1.5.5	Holdover Frequency Offset Read	29
3.10.1.6	Pre-Locked2 Mode	29
3.11	DPLL OUTPUT	30
3.11.1	PFD Output Limit	30
3.11.2	Frequency Offset Limit	30
3.11.3	PBO	30
3.11.4	Phase Offset Selection	30
3.11.5	Four Paths of T0 DPLL Outputs	30
3.11.5.1	T0 Path	30
3.12	T0 / T4 APLL	31
3.13	OUTPUT CLOCKS & FRAME SYNC SIGNALS	31
3.13.1	Output Clocks	31
3.13.2	Frame SYNC Output Signals	34
3.14	INTERRUPT SUMMARY	36
3.15	T0 SUMMARY	36
3.16	POWER SUPPLY FILTERING TECHNIQUES	37
3.17	LINE CARD APPLICATION	38
4	MICROPROCESSOR INTERFACE	39
5	JTAG	41
6	PROGRAMMING INFORMATION	42
6.1	REGISTER MAP	42
6.2	REGISTER DESCRIPTION	47
6.2.1	Global Control Registers	47
6.2.2	Interrupt Registers	54
6.2.3	Input Clock Frequency & Priority Configuration Registers	58
6.2.4	Input Clock Quality Monitoring Configuration & Status Registers	69
6.2.5	T0 DPLL Input Clock Selection Registers	80
6.2.6	T0 DPLL State Machine Control Registers	83
6.2.7	T0 DPLL & APLL Configuration Registers	85
6.2.8	Output Configuration Registers	96
6.2.9	PBO & Phase Offset Control Registers	99
6.2.10	Synchronization Configuration Registers	101
7	THERMAL MANAGEMENT	103
7.1	JUNCTION TEMPERATURE	103
7.2	EXAMPLE OF JUNCTION TEMPERATURE CALCULATION	103
7.3	HEATSINK EVALUATION	103
8	ELECTRICAL SPECIFICATIONS	104
8.1	ABSOLUTE MAXIMUM RATING	104
8.2	RECOMMENDED OPERATION CONDITIONS	104
8.3	I/O SPECIFICATIONS	105
8.3.1	CMOS Input / Output Port	105
8.3.2	PECL / LVDS Input / Output Port	106
8.3.2.1	PECL Input / Output Port	106
8.3.2.2	LVDS Input / Output Port	108
8.4	JITTER & WANDER PERFORMANCE	109
8.5	OUTPUT WANDER GENERATION	112
8.6	INPUT / OUTPUT CLOCK TIMING	113
8.7	OUTPUT CLOCK TIMING	114
	PACKAGE DIMENSIONS.....	120
	ORDERING INFORMATION.....	125



List of Tables

Table 1: Pin Description	11
Table 2: Related Bit / Register in Chapter 3.2	15
Table 3: Related Bit / Register in Chapter 3.3	16
Table 4: Related Bit / Register in Chapter 3.4	17
Table 5: Related Bit / Register in Chapter 3.5	19
Table 6: Input Clock Selection for T0 Path	20
Table 7: External Fast Selection	20
Table 8: 'n' Assigned to the Input Clock	21
Table 9: Related Bit / Register in Chapter 3.6	21
Table 10: Coarse Phase Limit Programming (the selected input clock of 2 kHz, 4 kHz or 8 kHz)	22
Table 11: Coarse Phase Limit Programming (the selected input clock of other than 2 kHz, 4 kHz and 8 kHz)	22
Table 12: Related Bit / Register in Chapter 3.7	23
Table 13: Conditions of Qualified Input Clocks Available for T0 Selection	24
Table 14: Related Bit / Register in Chapter 3.8	25
Table 15: T0 DPLL Operating Mode Control	26
Table 16: Frequency Offset Control in Temp-Holdover Mode	28
Table 17: Frequency Offset Control in Holdover Mode	29
Table 18: Holdover Frequency Offset Read	29
Table 19: Related Bit / Register in Chapter 3.12	31
Table 20: Outputs on OUT1 & OUT2 if Derived from T0 DPLL Outputs	31
Table 21: Outputs on OUT1 & OUT2 if Derived from T0 APLL	32
Table 22: Outputs on OUT1 & OUT2 if Derived from T4 APLL	33
Table 23: Frame Sync Input Signal Selection	34
Table 24: Synchronization Control	34
Table 25: Related Bit / Register in Chapter 3.13	35
Table 26: Related Bit / Register in Chapter 3.14	36
Table 27: Read Timing Characteristics in Serial Mode	40
Table 28: Write Timing Characteristics in Serial Mode	40
Table 29: JTAG Timing Characteristics	41
Table 30: Register List and Map	42
Table 31: Power Consumption and Maximum Junction Temperature	103
Table 32: Thermal Data	103
Table 33: Absolute Maximum Rating	104
Table 34: Recommended Operation Conditions	104
Table 35: CMOS Input Port Electrical Characteristics	105
Table 36: CMOS Input Port with Internal Pull-Up Resistor Electrical Characteristics	105
Table 37: CMOS Input Port with Internal Pull-Down Resistor Electrical Characteristics	105
Table 38: CMOS Output Port Electrical Characteristics	105
Table 39: PECL Input / Output Port Electrical Characteristics	107
Table 40: LVDS Input / Output Port Electrical Characteristics	108
Table 41: Output Clock Jitter Generation	109
Table 42: Output Clock Phase Noise	110
Table 43: Input Jitter Tolerance (155.52 MHz)	111
Table 44: Input Jitter Tolerance (1.544 MHz)	111
Table 45: Input Jitter Tolerance (2.048 MHz)	111
Table 46: Input Jitter Tolerance (8 kHz)	111
Table 47: T0 DPLL Jitter Transfer & Damping Factor	111
Table 48: Input/Output Clock Timing	113
Table 49: Output Clock Timing	115



List of Figures

Figure 1. Functional Block Diagram	9
Figure 2. Pin Assignment (Top View)	10
Figure 3. Pre-Divider for An Input Clock	17
Figure 4. Input Clock Activity Monitoring	18
Figure 5. External Fast Selection	20
Figure 6. T0 Selected Input Clock vs. DPLL Automatic Operating Mode	26
Figure 7. On Target Frame Sync Input Signal Timing	34
Figure 8. 0.5 UI Early Frame Sync Input Signal Timing	34
Figure 9. 0.5 UI Late Frame Sync Input Signal Timing	35
Figure 10. 1 UI Late Frame Sync Input Signal Timing	35
Figure 11. IDT82V3352 Power Decoupling Scheme	37
Figure 12. Line Card Application	38
Figure 13. Serial Read Timing Diagram (CLKE Asserted Low)	39
Figure 14. Serial Read Timing Diagram (CLKE Asserted High)	39
Figure 15. Serial Write Timing Diagram	40
Figure 16. JTAG Interface Timing Diagram	41
Figure 17. Recommended PECL Input Port Line Termination	106
Figure 18. Recommended PECL Output Port Line Termination	106
Figure 19. Recommended LVDS Input Port Line Termination	108
Figure 20. Recommended LVDS Output Port Line Termination	108
Figure 21. Output Wander Generation	112
Figure 22. Input / Output Clock Timing	113
Figure 23. 64-Pin PP Package Dimensions (a) (in Millimeters)	120
Figure 24. 64-Pin PP Package Dimensions (b) (in Millimeters)	121
Figure 25. 64-Pin EDG Package Dimensions (a) (in Millimeters)	122
Figure 26. 64-Pin EDG Package Dimensions (b) (in Millimeters)	123
Figure 27. EDG64 Recommended Land Pattern with Exposed Pad (in Millimeters)	124



FEATURES

HIGHLIGHTS

- The first single PLL chip:
 - Features 0.1 Hz to 560 Hz bandwidth
 - Provides node clock for ITU-T G.8261/G.8262 Synchronous Ethernet
 - Exceeds GR-253-CORE (OC-12) and ITU-T G.813 (STM-16/Option I) jitter generation requirements
 - Provides node clocks for Cellular and WLL base-station (GSM and 3G networks)
 - Provides clocks for DSL access concentrators (DSLAM), especially for Japan TCM-ISDN network timing based ADSL equipments

MAIN FEATURES

- Provides an integrated single-chip solution for Synchronous Equipment Timing Source, including Stratum 3, SMC, 4E and 4 clocks
- Employs DPLL and APLL to feature excellent jitter performance and minimize the number of the external components
- Supports Forced or Automatic operating mode switch controlled by an internal state machine; the primary operating modes are Free-Run, Locked and Holdover
- Supports programmable DPLL bandwidth (0.1 Hz to 560 Hz in 11 steps) and damping factor (1.2 to 20 in 5 steps)
- Supports 1.1×10^{-5} ppm absolute holdover accuracy and 4.4×10^{-8} ppm instantaneous holdover accuracy
- Supports PBO to minimize phase transients on T0 DPLL output to be no more than 0.61 ns
- Supports phase absorption when phase-time changes on T0 selected input clock are greater than a programmable limit over an interval of less than 0.1 seconds
- Supports programmable input-to-output phase offset adjustment
- Limits the phase and frequency offset of the outputs
- Supports manual and automatic selected input clock switch

- Supports automatic hitless selected input clock switch on clock failure
- Supports three types of input clock sources: recovered clock from STM-N or OC-n, PDH network synchronization timing and external synchronization reference timing
- Provides three 2 kHz, 4 kHz or 8 kHz frame sync input signals, and a 2 kHz and an 8 kHz frame sync output signals
- Provides 5 input clocks whose frequency cover from 2 kHz to 622.08 MHz
- Provides 2 output clocks whose frequency cover from 1 Hz to 622.08 MHz
- Provides output clocks for BITS, GPS, 3G, GSM, etc.
- Supports PECL/LVDS and CMOS input/output technologies
- Supports master clock calibration
- Supports Line Card application
- Meets Telcordia GR-1244-CORE, GR-253-CORE, ITU-T G.812, ITU-T G.813 and ITU-T G.783 criteria

OTHER FEATURES

- Serial microprocessor interface mode
- IEEE 1149.1 JTAG Boundary Scan
- Single 3.3 V operation with 5 V tolerant CMOS I/Os
- 64-pin TQFP package, Green package options available

APPLICATIONS

- BITS / SSU
- SMC / SEC (SONET / SDH)
- DWDM cross-connect and transmission equipments
- Synchronous Ethernet equipments
- Central Office Timing Source and Distribution
- Core and access IP switches / routers
- Gigabit and Terabit IP switches / routers
- IP and ATM core switches and access equipments
- Cellular and WLL base-station node clocks
- Broadband and multi-service access equipments
- Any other telecom equipments that need synchronous equipment system timing

DESCRIPTION

The IDT82V3352 is an integrated, single-chip solution for the Synchronous Equipment Timing Source for Stratum 3, SMC, 4E and 4 clocks in SONET / SDH equipments, DWDM and Wireless base station, such as GSM, 3G, DSL concentrator, Router and Access Network applications.

The device supports three types of input clock sources: recovered clock from STM-N or OC-n, PDH network synchronization timing and external synchronization reference timing.

The T0 path supports three primary operating modes: Free-Run, Locked and Holdover. In Free-Run mode, the DPLL refers to the master clock. In Locked mode, the DPLL locks to the selected input clock. In Holdover mode, the DPLL resorts to the frequency data acquired in Locked mode. Whatever the operating mode is, the DPLL gives a stable performance without being affected by operating conditions or silicon process variations.

If the DPLL outputs are processed by T0/T4 APLL, the outputs of the device will be in a better jitter/wander performance.

The device provides programmable DPLL bandwidths: 0.1 Hz to 560 Hz in 11 steps and damping factors: 1.2 to 20 in 5 steps. Different settings cover all SONET / SDH clock synchronization requirements.

A high stable input is required for the master clock in different applications. The master clock is used as a reference clock for all the internal circuits in the device. It can be calibrated within ± 741 ppm.

All the read/write registers are accessed through a serial microprocessor interface. The device supports Serial microprocessor interface mode only.

The device can be used typically in [Chapter 3.17 Line Card Application](#).

FUNCTIONAL BLOCK DIAGRAM

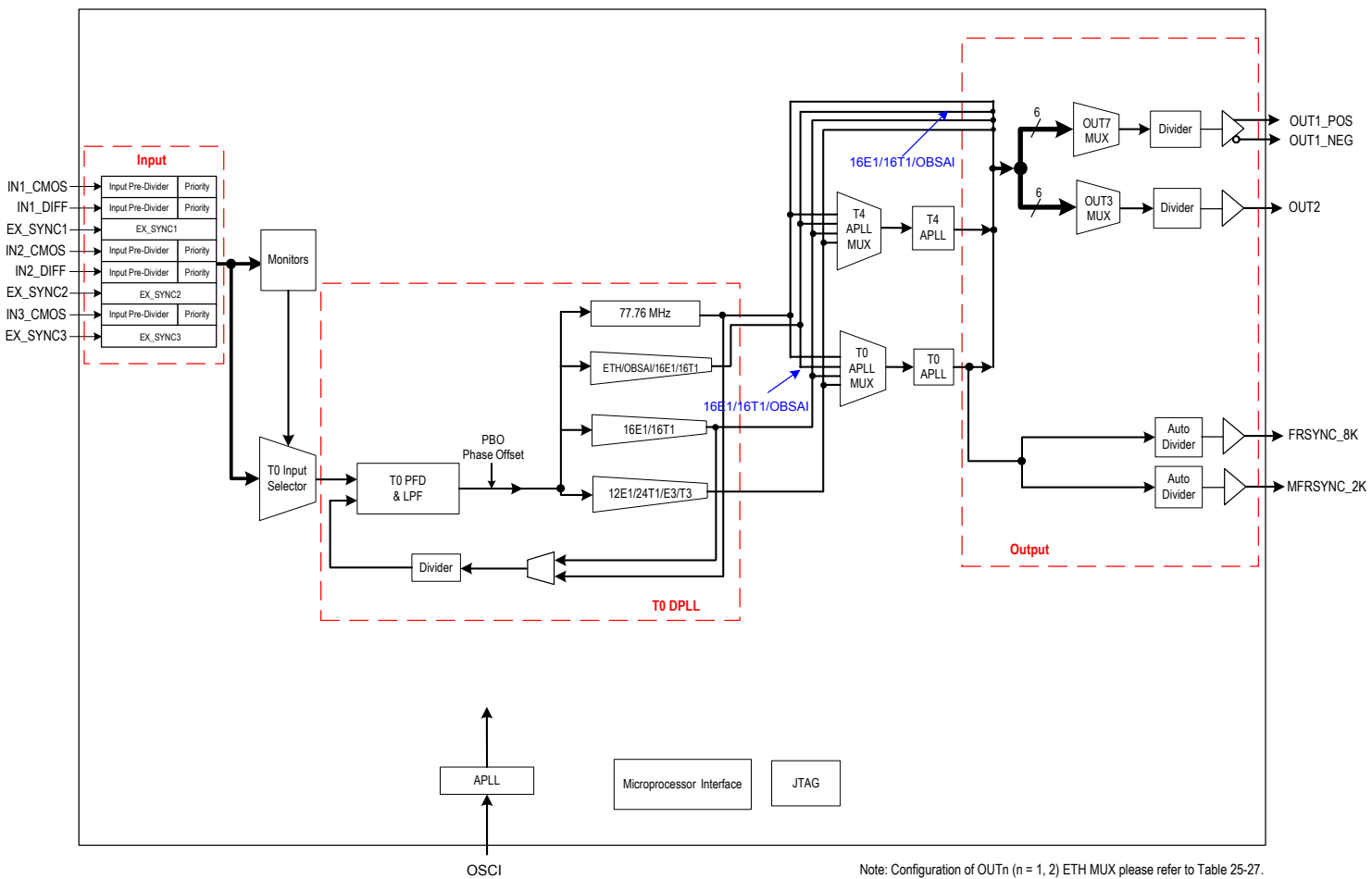

Note: Configuration of OUTn (n = 1, 2) ETH MUX please refer to Table 25-27.

Figure 1. Functional Block Diagram

1 PIN ASSIGNMENT

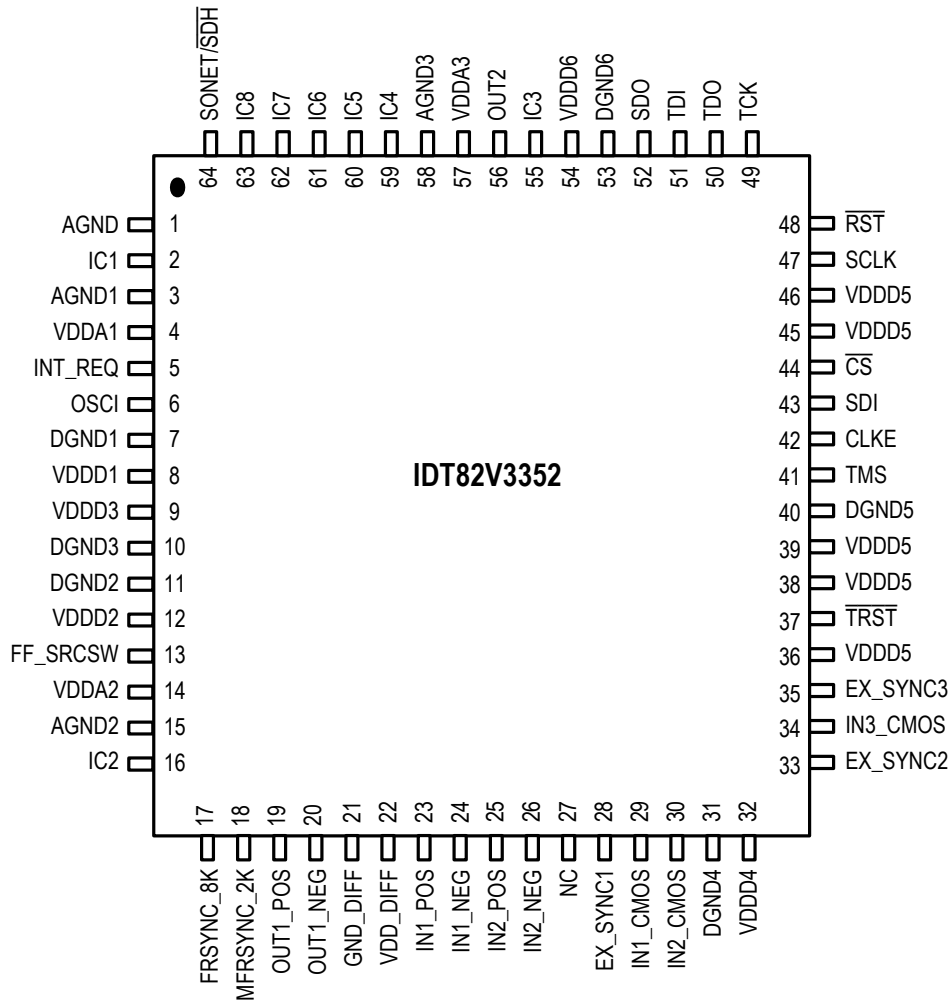

Figure 2. Pin Assignment (Top View)

2 PIN DESCRIPTION

Table 1: Pin Description

Name	Pin No.	I/O	Type	Description ¹
Global Control Signal				
OSCI	6	I	CMOS	OSCI: Crystal Oscillator Master Clock A nominal 12.8000 MHz clock provided by a crystal oscillator is input on this pin. It is the master clock for the device.
FF_SRCSW	13	I pull-down	CMOS	FF_SRCSW: External Fast Selection Enable During reset, this pin determines the default value of the EXT_SW bit (b4, 0BH) ² . The EXT_SW bit determines whether the External Fast Selection is enabled. High: The default value of the EXT_SW bit (b4, 0BH) is '1' (External Fast selection is enabled); Low: The default value of the EXT_SW bit (b4, 0BH) is '0' (External Fast selection is disabled). After reset, this pin selects an input clock pair for the T0 DPLL if the External Fast selection is enabled: High: Pair IN1_CMOS / IN1_DIFF is selected. Low: Pair IN2_CMOS / IN2_DIFF is selected. After reset, the input on this pin takes no effect if the External Fast selection is disabled.
SONET/SDH	64	I pull-down	CMOS	SONET/SDH: SONET / SDH Frequency Selection During reset, this pin determines the default value of the IN_SONET_SDH bit (b2, 09H): High: The default value of the IN_SONET_SDH bit is '1' (SONET); Low: The default value of the IN_SONET_SDH bit is '0' (SDH). After reset, the value on this pin takes no effect.
RST	48	I pull-up	CMOS	RST: Reset A low pulse of at least 50 μ s on this pin resets the device. After this pin is high, the device will still be held in reset state for 500 ms (typical).
Frame Synchronization Input Signal				
EX_SYNC1	28	I pull-down	CMOS	EX_SYNC1: External Sync Input 1 A 2 kHz, 4 kHz or 8 kHz signal is input on this pin.
EX_SYNC2	33	I pull-down	CMOS	EX_SYNC2: External Sync Input 2 A 2 kHz, 4 kHz or 8 kHz signal is input on this pin.
EX_SYNC3	35	I pull-down	CMOS	EX_SYNC3: External Sync Input 3 A 2 kHz, 4 kHz or 8 kHz signal is input on this pin.
Input Clock				
IN1_CMOS	29	I pull-down	CMOS	IN1_CMOS: Input Clock 1 A 2 kHz, 4 kHz, N x 8 kHz ³ , 1.544 MHz (SONET) / 2.048 MHz (SDH), 6.48 MHz, 19.44 MHz, 25.92 MHz, 38.88 MHz, 51.84 MHz, 77.76 MHz or 155.52 MHz clock is input on this pin.
IN2_CMOS	30	I pull-down	CMOS	IN2_CMOS: Input Clock 2 A 2 kHz, 4 kHz, N x 8 kHz ³ , 1.544 MHz (SONET) / 2.048 MHz (SDH), 6.48 MHz, 19.44 MHz, 25.92 MHz, 38.88 MHz, 51.84 MHz, 77.76 MHz or 155.52 MHz clock is input on this pin.
IN1_POS	23	I	PECL/LVDS	IN1_POS / IN1_NEG: Positive / Negative Input Clock 1 A 2 kHz, 4 kHz, N x 8 kHz ³ , 1.544 MHz (SONET) / 2.048 MHz (SDH), 6.48 MHz, 19.44 MHz, 25.92 MHz, 38.88 MHz, 51.84 MHz, 77.76 MHz, 155.52 MHz, 156.25 MHz, 311.04 MHz or 622.08 MHz clock is differentially input on this pair of pins. Whether the clock signal is PECL or LVDS is automatically detected.
IN1_NEG	24			
IN2_POS	25	I	PECL/LVDS	IN2_POS / IN2_NEG: Positive / Negative Input Clock 2 A 2 kHz, 4 kHz, N x 8 kHz ³ , 1.544 MHz (SONET) / 2.048 MHz (SDH), 6.48 MHz, 19.44 MHz, 25.92 MHz, 38.88 MHz, 51.84 MHz, 77.76 MHz, 155.52 MHz, 156.25 MHz, 311.04 MHz or 622.08 MHz clock is differentially input on this pair of pins. Whether the clock signal is PECL or LVDS is automatically detected.
IN2_NEG	26			

Table 1: Pin Description (Continued)

Name	Pin No.	I/O	Type	Description ¹
IN3_CMOS	34	I pull-down	CMOS	IN3_CMOS: Input Clock 3 A 2 kHz, 4 kHz, N x 8 kHz ³ , 1.544 MHz (SONET) / 2.048 MHz (SDH), 6.48 MHz, 19.44 MHz, 25.92 MHz, 38.88 MHz, 51.84 MHz, 77.76 MHz or 155.52 MHz clock is input on this pin.
Output Frame Synchronization Signal				
FRSYNC_8K	17	O	CMOS	FRSYNC_8K: 8 kHz Frame Sync Output An 8 kHz signal is output on this pin.
MFRSYNC_2K	18	O	CMOS	MFRSYNC_2K: 2 kHz Multiframe Sync Output A 2 kHz signal is output on this pin.
Output Clock				
OUT1_POS OUT1_NEG	19 20	O	PECL/LVDS	OUT1_POS / OUT1_NEG: Positive / Negative Output Clock 1 A 1 Hz, 400 Hz, 2 kHz, 8 kHz, 64 kHz, N x E1 ⁴ , N x T1 ⁵ , N x 13.0 MHz ⁶ , N x 3.84 MHz ⁷ , 5 MHz, 10 MHz, 20 MHz, 25 MHz, E3, T3, 6.48 MHz, 19.44 MHz, 25.92 MHz, 38.88 MHz, 51.84 MHz, 77.76 MHz, 125 MHz, 155.52 MHz, 156.25 MHz, 311.04 MHz, 312.5 MHz or 622.08 MHz clock is differentially output on this pair of pins.
OUT2	56	O	CMOS	OUT2: Output Clock 2 A 1 Hz, 400 Hz, 2 kHz, 8 kHz, 64 kHz, N x E1 ⁴ , N x T1 ⁵ , N x 13.0 MHz ⁶ , N x 3.84 MHz ⁷ , 5 MHz, 10 MHz, 20 MHz, 25 MHz, E3, T3, 6.48 MHz, 19.44 MHz, 25.92 MHz, 38.88 MHz, 51.84 MHz, 77.76 MHz, 125 MHz, 155.52 MHz, 156.25 MHz or 312.5 MHz clock is output on this pin.
Microprocessor Interface				
$\overline{\text{CS}}$	44	I pull-up	CMOS	$\overline{\text{CS}}$: Chip Selection A transition from high to low must occur on this pin for each read or write operation and this pin should remain low until the operation is over.
INT_REQ	5	O	CMOS	INT_REQ: Interrupt Request This pin is used as an interrupt request. The output characteristics are determined by the HZ_EN bit (b1, 0CH) and the INT_POL bit (b0, 0CH).
SDI CLKE	43 42	I pull-down	CMOS	SDI: Serial Data Input In Serial mode, this pin is used as the serial data input. Address and data on this pin are serially clocked into the device on the rising edge of SCLK. CLKE: SCLK Active Edge Selection In Serial mode, this pin selects the active edge of SCLK to update the SDO: High - The falling edge; Low - The rising edge.
SDO	52	I/O pull-down	CMOS	SDO: Serial Data Output In Serial mode, this pin is used as the serial data output. Data on this pin is serially clocked out of the device on the active edge of SCLK.
SCLK	47	I pull-down	CMOS	SCLK: Shift Clock In Serial mode, a shift clock is input on this pin. Data on SDI is sampled by the device on the rising edge of SCLK. Data on SDO is updated on the active edge of SCLK. The active edge is determined by the CLKE.
JTAG (per IEEE 1149.1)				
$\overline{\text{TRST}}$	37	I pull-down	CMOS	$\overline{\text{TRST}}$: JTAG Test Reset (Active Low) A low signal on this pin resets the JTAG test port. This pin should be connected to ground when JTAG is not used.
TMS	41	I pull-up	CMOS	TMS: JTAG Test Mode Select The signal on this pin controls the JTAG test performance and is sampled on the rising edge of TCK.

Table 1: Pin Description (Continued)

Name	Pin No.	I/O	Type	Description ¹
TCK	49	I pull-down	CMOS	TCK: JTAG Test Clock The clock for the JTAG test is input on this pin. TDI and TMS are sampled on the rising edge of TCK and TDO is updated on the falling edge of TCK. If TCK is idle at a low level, all stored-state devices contained in the test logic will indefinitely retain their state.
TDI	51	I pull-up	CMOS	TDI: JTAG Test Data Input The test data is input on this pin. It is clocked into the device on the rising edge of TCK.
TDO	50	O	CMOS	TDO: JTAG Test Data Output The test data is output on this pin. It is clocked out of the device on the falling edge of TCK. TDO pin outputs a high impedance signal except during the process of data scanning. This pin can indicate the interrupt of T0 selected input clock fail, as determined by the LOS_FLAG_ON_TDO bit (b6, 0BH). Refer to Chapter 3.8.1 Input Clock Validity for details.
Power & Ground				
VDDD1	8	Power	-	VDDDn: 3.3 V Digital Power Supply Each VDDDn should be paralleled with ground through a 0.1 μ F capacitor.
VDDD2	12			
VDDD3	9			
VDDD4	32			
VDDD5	36, 38, 39, 45, 46			
VDDD6	54			
VDDA1	4	Power	-	VDDAn: 3.3 V Analog Power Supply Each VDDAn should be paralleled with ground through a 0.1 μ F capacitor.
VDDA2	14			
VDDA3	57			
VDD_DIFF	22	Power	-	VDD_DIFF: 3.3 V Power Supply for OUT1
DGND1	7	Ground	-	DGNDn: Digital Ground
DGND2	11			
DGND3	10			
DGND4	31			
DGND5	40			
DGND6	53			
AGND1	3	Ground	-	AGNDn: Analog Ground
AGND2	15			
AGND3	58			
GND_DIFF	21	Ground	-	GND_DIFF: Ground for OUT1
AGND	1	Ground	-	AGND: Analog Ground

Table 1: Pin Description (Continued)

Name	Pin No.	I/O	Type	Description ¹
Others				
IC1	2			IC: Internal Connected Internal Use. These pins should be left open for normal operation.
IC2	16			
IC3	55			
IC4	59			
IC5	60	-	-	
IC6	61			
IC7	62			
IC8	63			
NC	27	-	-	NC: Not Connected
Note:				
1. All the unused input pins should be connected to ground; the output of all the unused output pins are don't-care.				
2. The contents in the brackets indicate the position of the register bit/bits.				
3. N x 8 kHz: $1 \leq N \leq 19440$.				
4. N x E1: N = 1, 2, 3, 4, 6, 8, 12, 16, 24, 32, 48, 64.				
5. N x T1: N = 1, 2, 3, 4, 6, 8, 12, 16, 24, 32, 48, 64, 96.				
6. N x 13.0 MHz: N = 1, 2, 4.				
7. N x 3.84 MHz: N = 1, 2, 4, 8, 16, 10, 20, 40.				

3 FUNCTIONAL DESCRIPTION

3.1 RESET

The reset operation resets all registers and state machines to their default value or status.

After power on, the device must be reset for normal operation.

For a complete reset, the \overline{RST} pin must be asserted low for at least 50 μ s. After the \overline{RST} pin is pulled high, the device will still be in reset state for 500 ms (typical). If the \overline{RST} pin is held low continuously, the device remains in reset state.

3.2 MASTER CLOCK

A nominal 12.8000 MHz clock, provided by a crystal oscillator, is input on the OSCI pin. This clock is provided for the device as a master clock. The master clock is used as a reference clock for all the internal circuits. A better active edge of the master clock is selected by the OSC_EDGE bit to improve jitter and wander performance.

In fact, an offset from the nominal frequency may input on the OSCI pin. This offset can be compensated by setting the NOMINAL_FREQ_VALUE[23:0] bits. The calibration range is within ± 741 ppm.

The performance of the master clock should meet GR-1244-CORE, GR-253-CORE, ITU-T G.812 and G.813 criteria.

Table 2: Related Bit / Register in Chapter 3.2

Bit	Register	Address (Hex)
NOMINAL_FREQ_VALUE[23:0]	NOMINAL_FREQ[23:16]_CNFG, NOMINAL_FREQ[15:8]_CNFG, NOMINAL_FREQ[7:0]_CNFG	06, 05, 04
OSC_EDGE	DIFFERENTIAL_IN_OUT_OSCI_CNFG	0A

3.3 INPUT CLOCKS & FRAME SYNC SIGNALS

Altogether 5 clocks and 3 frame sync signals are input to the device.

3.3.1 INPUT CLOCKS

The device provides 5 input clock ports.

According to the input port technology, the input ports support the following technologies:

- PECL/LVDS
- CMOS

According to the input clock source, the following clock sources are supported:

- T1: Recovered clock from STM-N or OC-n
- T2: PDH network synchronization timing
- T3: External synchronization reference timing

IN1_CMOS ~ IN3_CMOS support CMOS input signal only and the clock sources can be from T1, T2 or T3.

IN1_DIFF and IN2_DIFF support PECL/LVDS input signal only and automatically detect whether the signal is PECL or LVDS. The clock sources can be from T1, T2 or T3.

For SDH and SONET networks, the default frequency is different. SONET / SDH frequency selection is controlled by the IN_SONET_SDH bit. During reset, the default value of the IN_SONET_SDH bit is determined by the SONET/SDH pin: high for SONET and low for SDH. After reset, the input signal on the SONET/SDH pin takes no effect.

3.3.2 FRAME SYNC INPUT SIGNALS

Three 2 kHz, 4 kHz or 8 kHz frame sync signals are input on the EX_SYNC1 to EX_SYNC3 pins respectively. They are CMOS inputs. The input frequency should match the setting in the SYNC_FREQ[1:0] bits.

Only one of the three frame sync input signals is used for frame sync output signal synchronization. Refer to [Chapter 3.13.2 Frame SYNC Output Signals](#) for details.

Table 3: Related Bit / Register in Chapter 3.3

Bit	Register	Address (Hex)
IN_SONET_SDH	INPUT_MODE_CNFG	09
SYNC_FREQ[1:0]		

3.4 INPUT CLOCK PRE-DIVIDER

Each input clock is assigned an internal Pre-Divider. The Pre-Divider is used to divide the clock frequency down to the DPLL required frequency, which is no more than 38.88 MHz. For each input clock, the DPLL required frequency is set by the corresponding IN_FREQ[3:0] bits.

If the input clock is of 2 kHz, 4 kHz or 8 kHz, the Pre-Divider is bypassed automatically and the corresponding IN_FREQ[3:0] bits should be set to match the input frequency; the input clock can be inverted, as determined by the IN_2K_4K_8K_INV bit.

Each Pre-Divider consists of a HF (High Frequency) Divider (only available for IN1_DIFF and IN2_DIFF), a DivN Divider and a Lock 8k Divider, as shown in Figure 3.

The HF Divider, which is only available for IN1_DIFF and IN2_DIFF, should be used when the input clock is higher than (>) 155.52 MHz. The input clock can be divided by 4, 5 or can bypass the HF Divider, as determined by the IN1_DIFF_DIV[1:0]/IN2_DIFF_DIV[1:0] bits correspondingly.

Either the DivN Divider or the Lock 8k Divider can be used or both can be bypassed, as determined by the DIRECT_DIV bit and the LOCK_8K bit.

When the DivN Divider is used, the division factor setting should observe the following order:

1. Select an input clock by the PRE_DIV_CH_VALUE[3:0] bits;
2. Write the lower eight bits of the division factor to the PRE_DIVN_VALUE[7:0] bits;
3. Write the higher eight bits of the division factor to the PRE_DIVN_VALUE[14:8] bits.

Once the division factor is set for the input clock selected by the PRE_DIV_CH_VALUE[3:0] bits, it is valid until a different division factor is set for the same input clock. The division factor is calculated as follows:

$$\text{Division Factor} = (\text{the frequency of the clock input to the DivN Divider} \div \text{the frequency of the DPLL required clock set by the IN_FREQ[3:0] bits}) - 1$$

The DivN Divider can only divide the input clock whose frequency is lower than (<) 155.52 MHz.

When the Lock 8k Divider is used, the input clock is divided down to 8 kHz automatically.

The Pre-Divider configuration and the division factor setting depend on the input clock on one of the clock input pin and the DPLL required clock. Here is an example:

The input clock on the IN2_DIFF pin is 622.08 MHz; the DPLL required clock is 6.48 MHz by programming the IN_FREQ[3:0] bits of register IN2_DIFF to '0010'. Do the following step by step to divide the input clock:

1. Use the HF Divider to divide the clock down to 155.52 MHz:
 $622.08 \div 155.52 = 4$, so set the IN2_DIFF_DIV[1:0] bits to '01';
2. Use the DivN Divider to divide the clock down to 6.48 MHz:
 Set the PRE_DIV_CH_VALUE[3:0] bits to '0110';
 Set the DIRECT_DIV bit in Register IN2_DIFF_CNFG to '1' and the LOCK_8K bit in Register IN2_DIFF_CNFG to '0';
 $155.52 \div 6.48 = 24$; $24 - 1 = 23$, so set the PRE_DIVN_VALUE[14:0] bits to '10111'.

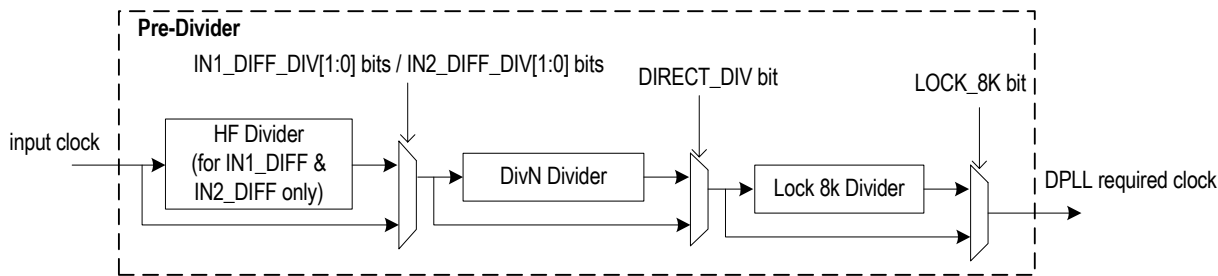

Figure 3. Pre-Divider for An Input Clock

Table 4: Related Bit / Register in Chapter 3.4

Bit	Register	Address (Hex)
IN1_DIFF_DIV[1:0]	IN1_DIFF_IN2_DIFF_HF_DIV_CNFG	18
IN2_DIFF_DIV[1:0]		
IN_FREQ[3:0]	IN1_CMOS_CNFG, IN2_CMOS_CNFG, IN1_DIFF_CNFG, IN2_DIFF_CNFG, IN3_CNFG	16, 17, 19, 1A, 1D
DIRECT_DIV		
LOCK_8K		
IN_2K_4K_8K_INV	FR_MFR_SYNC_CNFG	74
PRE_DIV_CH_VALUE[3:0]	PRE_DIV_CH_CNFG	23
PRE_DIVN_VALUE[14:0]	PRE_DIVN[14:8]_CNFG, PRE_DIVN[7:0]_CNFG	25, 24

3.5 INPUT CLOCK QUALITY MONITORING

The qualities of all the input clocks are always monitored in the following aspects:

- Activity
- Frequency

The qualified clocks are available for T0 DPLL selection. The T0 selected input clocks have to be monitored further. Refer to [Chapter 3.7 Selected Input Clock Monitoring](#) for details.

3.5.1 ACTIVITY MONITORING

Activity is monitored by using an internal leaky bucket accumulator, as shown in [Figure 4](#).

Each input clock is assigned an internal leaky bucket accumulator. The input clock is monitored for each period of 128 ms and the internal leaky bucket accumulator increases by 1 when an event is detected; it decreases by 1 if no event is detected within the period set by the decay rate. The event is that an input clock drifts outside ($>$) ± 500 ppm with respect to the master clock within a 128 ms period.

There are four configurations (0 - 3) for a leaky bucket accumulator. The leaky bucket configuration for an input clock is selected by the cor-

responding BUCKET_SEL[1:0] bits. Each leaky bucket configuration consists of four elements: upper threshold, lower threshold, bucket size and decay rate.

The bucket size is the capability of the accumulator. If the number of the accumulated events reach the bucket size, the accumulator will stop increasing even if further events are detected. The upper threshold is a point above which a no-activity alarm is raised. The lower threshold is a point below which the no-activity alarm is cleared. The decay rate is a certain period during which the accumulator decreases by 1 if no event is detected.

The leaky bucket configuration is programmed by one of four groups of register bits: the BUCKET_SIZE_n_DATA[7:0] bits, the UPPER_THRESHOLD_n_DATA[7:0] bits, the LOWER_THRESHOLD_n_DATA[7:0] bits and the DECAY_RATE_n_DATA[1:0] bits respectively; 'n' is 0 ~ 3.

The no-activity alarm status of the input clock is indicated by the INn_CMOS_NO_ACTIVITY_ALARM bit (n = 1, 2, or 3) / INn_DIFF_NO_ACTIVITY_ALARM bit (n = 1 or 2).

The input clock with a no-activity alarm is disqualified for clock selection for T0 DPLL.

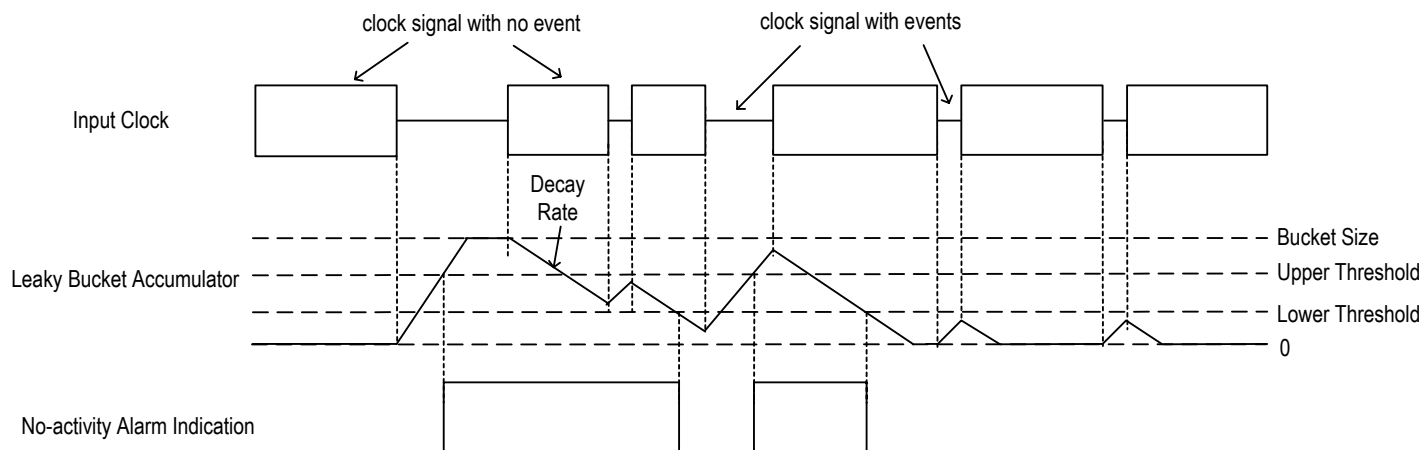

Figure 4. Input Clock Activity Monitoring

3.5.2 FREQUENCY MONITORING

Frequency is monitored by comparing the input clock with a reference clock. The reference clock can be derived from the master clock or the output of T0 DPLL, as determined by the `FREQ_MON_CLK` bit.

A frequency hard alarm threshold is set for frequency monitoring. If the `FREQ_MON_HARD_EN` bit is '1', a frequency hard alarm is raised when the frequency of the input clock with respect to the reference clock is above the threshold; the alarm is cleared when the frequency is below the threshold.

The frequency hard alarm threshold can be calculated as follows:

$$\text{Frequency Hard Alarm Threshold (ppm)} = (\text{ALL_FREQ_HARD_THRESHOLD}[3:0] + 1) \times \text{FREQ_MON_FACTOR}[3:0]$$

If the `FREQ_MON_HARD_EN` bit is '1', the frequency hard alarm status of the input clock is indicated by the `INn_CMOS_FREQ_HARD_ALARM` bit ($n = 1, 2$ or 3) / `INn_DIFF_FREQ_HARD_ALARM` bit ($n = 1$ or 2). When the `FREQ_MON_HARD_EN` bit is '0', no frequency hard alarm is raised even if the input clock is above the frequency hard alarm threshold.

The input clock with a frequency hard alarm is disqualified for clock selection for T0 DPLL.

In addition, if the input clock is 2 kHz, 4 kHz or 8 kHz, its clock edges with respect to the reference clock are monitored. If any edge drifts outside $\pm 5\%$, the input clock is disqualified for clock selection for T0 DPLL. The input clock is qualified if any edge drifts inside $\pm 5\%$. This function is supported only when the `IN_NOISE_WINDOW` bit is '1'.

The frequency of each input clock with respect to the reference clock can be read by doing the following step by step:

1. Select an input clock by setting the `IN_FREQ_READ_CH[3:0]` bits;
2. Read the value in the `IN_FREQ_VALUE[7:0]` bits and calculate as follows:

$$\text{Input Clock Frequency (ppm)} = \text{IN_FREQ_VALUE}[7:0] \times \text{FREQ_MON_FACTOR}[3:0]$$

Note that the value set by the `FREQ_MON_FACTOR[3:0]` bits depends on the application.

Table 5: Related Bit / Register in Chapter 3.5

Bit	Register	Address (Hex)
<code>BUCKET_SIZE_n_DATA[7:0]</code> ($3 \geq n \geq 0$)	<code>BUCKET_SIZE_0_CNFG ~ BUCKET_SIZE_3_CNFG</code>	33, 37, 3B, 3F
<code>UPPER_THRESHOLD_n_DATA[7:0]</code> ($3 \geq n \geq 0$)	<code>UPPER_THRESHOLD_0_CNFG ~ UPPER_THRESHOLD_3_CNFG</code>	31, 35, 39, 3D
<code>LOWER_THRESHOLD_n_DATA[7:0]</code> ($3 \geq n \geq 0$)	<code>LOWER_THRESHOLD_0_CNFG ~ LOWER_THRESHOLD_3_CNFG</code>	32, 36, 3A, 3E
<code>DECAY_RATE_n_DATA[1:0]</code> ($3 \geq n \geq 0$)	<code>DECAY_RATE_0_CNFG ~ DECAY_RATE_3_CNFG</code>	34, 38, 3C, 40
<code>BUCKET_SEL[1:0]</code>	<code>IN1_CMOS_CNFG, IN2_CMOS_CNFG, IN1_DIFF_CNFG, IN2_DIFF_CNFG, IN3_CMOS_CNFG</code>	16, 17, 19, 1A, 1D
<code>INn_CMOS_NO_ACTIVITY_ALARM</code> ($n = 1, 2, \text{ or } 3$)	<code>IN1_IN2_CMOS_STS, IN3_CMOS_STS</code>	44, 47
<code>INn_CMOS_FREQ_HARD_ALARM</code> ($n = 1, 2 \text{ or } 3$)		
<code>INn_DIFF_NO_ACTIVITY_ALARM</code> ($n = 1 \text{ or } 2$)	<code>IN1_IN2_DIFF_STS</code>	45
<code>INn_DIFF_FREQ_HARD_ALARM</code> ($n = 1 \text{ or } 2$)		
<code>FREQ_MON_CLK</code>	<code>MON_SW_PBO_CNFG</code>	0B
<code>FREQ_MON_HARD_EN</code>		
<code>ALL_FREQ_HARD_THRESHOLD[3:0]</code>	<code>ALL_FREQ_MON_THRESHOLD_CNFG</code>	2F
<code>FREQ_MON_FACTOR[3:0]</code>	<code>FREQ_MON_FACTOR_CNFG</code>	2E
<code>IN_NOISE_WINDOW</code>	<code>PHASE_MON_PBO_CNFG</code>	78
<code>IN_FREQ_READ_CH[3:0]</code>	<code>IN_FREQ_READ_CH_CNFG</code>	41
<code>IN_FREQ_VALUE[7:0]</code>	<code>IN_FREQ_READ_STS</code>	42

3.6 DPLL INPUT CLOCK SELECTION

The EXT_SW bit and the T0_INPUT_SEL[3:0] bits determine the input clock selection, as shown in Table 6:

Table 6: Input Clock Selection for T0 Path

Control Bits		Input Clock Selection
EXT_SW	T0_INPUT_SEL[3:0]	
1	don't-care	External Fast selection
0	other than 0000	Forced selection
	0000	Automatic selection

External Fast selection is done between IN1_CMOS/IN1_DIFF and IN2_CMOS/IN2_DIFF pairs.

Forced selection is done by setting the related registers.

Automatic selection is done based on the results of input clocks quality monitoring and the related registers configuration.

The selected input clock is attempted to be locked in T0 DPLL.

3.6.1 EXTERNAL FAST SELECTION

The External Fast selection is supported by T0 path only. In External Fast selection, only IN1_CMOS/IN1_DIFF and IN2_CMOS/IN2_DIFF pairs are available for selection. Refer to Figure 5. The results of input

clocks quality monitoring (refer to Chapter 3.5 Input Clock Quality Monitoring) do not affect input clock selection.

The T0 input clock selection is determined by the FF_SRCSW pin after reset (this pin determines the default value of the EXT_SW bit during reset, refer to Chapter 2 Pin Description), the IN1_CMOS_SEL_PRIORITY[3:0] bits and the IN2_CMOS_SEL_PRIORITY[3:0] bits, as shown in Figure 5 and Table 7:

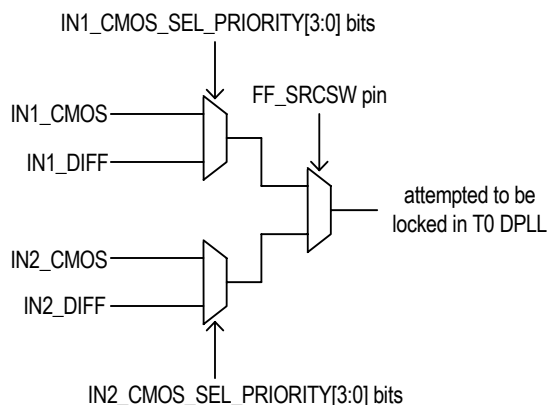

Figure 5. External Fast Selection

Table 7: External Fast Selection

Control Pin & Bits			the Selected Input Clock
FF_SRCSW (after reset)	IN1_CMOS_SEL_PRIORITY[3:0]	IN2_CMOS_SEL_PRIORITY[3:0]	
high	0000	don't-care	IN1_DIFF
	other than 0000		IN1_CMOS
low	don't-care	0000	IN2_DIFF
		other than 0000	IN2_CMOS

3.6.2 FORCED SELECTION

In Forced selection, the selected input clock is set by the T0_INPUT_SEL[3:0] bits. The results of input clocks quality monitoring (refer to [Chapter 3.5 Input Clock Quality Monitoring](#)) do not affect the input clock selection.

3.6.3 AUTOMATIC SELECTION

In Automatic selection, the input clock selection is determined by its validity and priority. The validity depends on the results of input clock quality monitoring (refer to [Chapter 3.5 Input Clock Quality Monitoring](#)). In all the qualified input clocks, the one with the highest priority is selected. The priority is configured by the corresponding IN_n_CMOS_SEL_PRIORITY[3:0] bits (n = 1, 2 or 3) / the

IN_n_DIFF_SEL_PRIORITY[3:0] bits (n = 1 or 2). If more than one qualified input clock is available and has the same priority, the input clock with the smallest 'n' is selected. See [Table 8](#) for the 'n' assigned to the input clock.

Table 8: 'n' Assigned to the Input Clock

Input Clock	'n' Assigned to the Input Clock
IN1_CMOS	1
IN1_DIFF	2
IN2_CMOS	3
IN2_DIFF	4
IN3_CMOS	5

Table 9: Related Bit / Register in Chapter 3.6

Bit	Register	Address (Hex)
EXT_SW	MON_SW_PBO_CNFG	0B
T0_INPUT_SEL[3:0]	T0_INPUT_SEL_CNFG	50
IN _n _CMOS_SEL_PRIORITY[3:0] (n = 1, 2 or 3)	IN1_IN2_CMOS_SEL_PRIORITY_CNFG, IN3_CMOS_SEL_PRIORITY_CNFG	27 *, 2A *
IN _n _DIFF_SEL_PRIORITY[3:0] (n = 1 or 2)	IN1_IN2_DIFF_SEL_PRIORITY_CNFG	28 *

3.7 SELECTED INPUT CLOCK MONITORING

The quality of the selected input clock is always monitored (refer to [Chapter 3.5 Input Clock Quality Monitoring](#)) and the DPLL locking status is always monitored.

3.7.1 DPLL LOCKING DETECTION

The following events is always monitored:

- Fast Loss;
- Coarse Phase Loss;
- Fine Phase Loss;
- Hard Limit Exceeding.

3.7.1.1 Fast Loss

A fast loss is triggered when the selected input clock misses 2 consecutive clock cycles. It is cleared once an active clock edge is detected.

The occurrence of the fast loss will result in T0 DPLL unlocked if the FAST_LOS_SW bit is '1'.

3.7.1.2 Coarse Phase Loss

The T0 DPLL compares the selected input clock with the feedback signal. If the phase-compared result exceeds the coarse phase limit, a coarse phase loss is triggered. It is cleared once the phase-compared result is within the coarse phase limit.

When the selected input clock is of 2 kHz, 4 kHz or 8 kHz, the coarse phase limit depends on the MULTI_PH_8K_4K_2K_EN bit, the WIDE_EN bit and the PH_LOS_COARSE_LIMT[3:0] bits. Refer to [Table 10](#). When the selected input clock is of other frequencies but 2 kHz, 4 kHz and 8 kHz, the coarse phase limit depends on the WIDE_EN bit and the PH_LOS_COARSE_LIMT[3:0] bits. Refer to [Table 11](#).

Table 10: Coarse Phase Limit Programming (the selected input clock of 2 kHz, 4 kHz or 8 kHz)

MULTI_PH_8K_4K_2K_EN	WIDE_EN	Coarse Phase Limit
0	don't-care	±1 UI
1	0	±1 UI
	1	set by the PH_LOS_COARSE_LIMT[3:0] bits

Table 11: Coarse Phase Limit Programming (the selected input clock of other than 2 kHz, 4 kHz and 8 kHz)

WIDE_EN	Coarse Phase Limit
0	±1 UI
1	set by the PH_LOS_COARSE_LIMT[3:0] bits

The occurrence of the coarse phase loss will result in T0 DPLL unlocked if the COARSE_PH_LOS_LIMT_EN bit is '1'.

3.7.1.3 Fine Phase Loss

The T0 DPLL compares the selected input clock with the feedback signal. If the phase-compared result exceeds the fine phase limit pro-

grammed by the PH_LOS_FINE_LIMT[2:0] bits, a fine phase loss is triggered. It is cleared once the phase-compared result is within the fine phase limit.

The occurrence of the fine phase loss will result in T0 DPLL unlocked if the FINE_PH_LOS_LIMT_EN bit is '1'.

3.7.1.4 Hard Limit Exceeding

Two limits are available for this monitoring. They are DPLL soft limit and DPLL hard limit. When the frequency of the DPLL output with respect to the master clock exceeds the DPLL soft / hard limit, a DPLL soft / hard alarm will be raised; the alarm is cleared once the frequency is within the corresponding limit. The occurrence of the DPLL soft alarm does not affect the T0 DPLL locking status. The DPLL soft alarm is indicated by the corresponding T0_DPLL_SOFT_FREQ_ALARM bit. The occurrence of the DPLL hard alarm will result in T0 DPLL unlocked if the FREQ_LIMT_PH_LOS bit is '1'.

The DPLL soft limit is set by the DPLL_FREQ_SOFT_LIMT[6:0] bits and can be calculated as follows:

$$DPLL \text{ Soft Limit (ppm)} = DPLL_FREQ_SOFT_LIMT[6:0] \times 0.724$$

The DPLL hard limit is set by the DPLL_FREQ_HARD_LIMT[15:0] bits and can be calculated as follows:

$$DPLL \text{ Hard Limit (ppm)} = DPLL_FREQ_HARD_LIMT[15:0] \times 0.0014$$

3.7.2 LOCKING STATUS

The DPLL locking status depends on the locking monitoring results. The DPLL is in locked state if none of the following events is triggered during 2 seconds; otherwise, the DPLL is unlocked.

- Fast Loss (the FAST_LOS_SW bit is '1');
- Coarse Phase Loss (the COARSE_PH_LOS_LIMT_EN bit is '1');
- Fine Phase Loss (the FINE_PH_LOS_LIMT_EN bit is '1');
- DPLL Hard Alarm (the FREQ_LIMT_PH_LOS bit is '1').

If the FAST_LOS_SW bit, the COARSE_PH_LOS_LIMT_EN bit, the FINE_PH_LOS_LIMT_EN bit or the FREQ_LIMT_PH_LOS bit is '0', the DPLL locking status will not be affected even if the corresponding event is triggered. If all these bits are '0', the DPLL will be in locked state in 2 seconds.

The DPLL locking status is indicated by the T0_DPLL_LOCK.

3.7.3 PHASE LOCK ALARM

A phase lock alarm will be raised when the selected input clock can not be locked in T0 DPLL within a certain period. This period can be calculated as follows:

$$Period \text{ (sec.)} = TIME_OUT_VALUE[5:0] \times MULTI_FACTOR[1:0]$$

The phase lock alarm is indicated by the corresponding INn_CMOS_PH_LOCK_ALARM bit (n = 1, 2 or 3) / INn_DIFF_PH_LOCK_ALARM bit (n = 1 or 2).

The phase lock alarm can be cleared by the following two ways, as selected by the PH_ALARM_TIMEOUT bit:

- Be cleared when a '1' is written to the corresponding `INn_CMOS_PH_LOCK_ALARM` / `INn_DIFF_PH_LOCK_ALARM` bit;
- Be cleared after the period ($= \text{TIME_OUT_VALUE}[5:0] \times \text{MULTI_FACTOR}[1:0]$ in second) which starts from when the alarm is raised.

The selected input clock with a phase lock alarm is disqualified for T0 DPLL locking.

Table 12: Related Bit / Register in Chapter 3.7

Bit	Register	Address (Hex)
FAST_LOS_SW	PHASE_LOSS_FINE_LIMIT_CNFG	5B *
PH_LOS_FINE_LIMIT[2:0]		
FINE_PH_LOS_LIMIT_EN		
MULTI_PH_8K_4K_2K_EN	PHASE_LOSS_COARSE_LIMIT_CNFG	5A *
WIDE_EN		
PH_LOS_COARSE_LIMIT[3:0]		
COARSE_PH_LOS_LIMIT_EN	OPERATING_STS	52
T0_DPLL_SOFT_FREQ_ALARM		
T0_DPLL_LOCK	DPLL_FREQ_SOFT_LIMIT_CNFG	65
DPLL_FREQ_SOFT_LIMIT[6:0]		
FREQ_LIMIT_PH_LOS		
DPLL_FREQ_HARD_LIMIT[15:0]	DPLL_FREQ_HARD_LIMIT[15:8]_CNFG, DPLL_FREQ_HARD_LIMIT[7:0]_CNFG	67, 66
TIME_OUT_VALUE[5:0]	PHASE_ALARM_TIME_OUT_CNFG	08
MULTI_FACTOR[1:0]		
INn_CMOS_PH_LOCK_ALARM (n = 1, 2, or 3)	IN1_IN2_CMOS_STS, IN3_CMOS_STS	44, 47
INn_DIFF_PH_LOCK_ALARM (n = 1 or 2)	IN1_IN2_DIFF_STS	45
PH_ALARM_TIMEOUT	INPUT_MODE_CNFG	09

3.8 SELECTED INPUT CLOCK SWITCH

If the input clock is selected by External Fast selection or by Forced selection, it can be switched by setting the related registers (refer to [Chapter 3.6.1 External Fast Selection](#) & [Chapter 3.6.2 Forced Selection](#)) any time. In this case, whether the input clock is qualified for DPLL locking does not affect the clock switch.

When the input clock is selected by Automatic selection, the input clock switch depends on its validity and priority. If the current selected input clock is disqualified, a new qualified input clock may be switched to.

3.8.1 INPUT CLOCK VALIDITY

For all the input clocks, the validity depends on the results of input clock quality monitoring (refer to [Chapter 3.5 Input Clock Quality Monitoring](#)). When all of the following conditions are satisfied, the input clock is valid; otherwise, it is invalid.

- No no-activity alarm (the `INn_CMOS_NO_ACTIVITY_ALARM` / `INn_DIFF_NO_ACTIVITY_ALARM` bit is '0');
- No frequency hard alarm (the `INn_CMOS_FREQ_HARD_ALARM` / `INn_DIFF_FREQ_HARD_ALARM` bit is '0');
- If the `IN_NOISE_WINDOW` bit is '1', all the edges of the input clock of 2 kHz, 4 kHz or 8 kHz drift inside $\pm 5\%$; if the `IN_NOISE_WINDOW` bit is '0', this condition is ignored.

The T0 selected input clock is valid when all of the above and the following conditions are satisfied; otherwise, it is invalid.

- No phase lock alarm, i.e., the `INn_CMOS_PH_LOCK_ALARM` / `INn_DIFF_PH_LOCK_ALARM` bit is '0';
- If the `ULTR_FAST_SW` bit is '1', the T0 selected input clock misses less than (<) 2 consecutive clock cycles; if the `ULTR_FAST_SW` bit is '0', this condition is ignored.

The validities of all the input clocks are indicated by the `INn_CMOS1` bit ($n = 1, 2$ or 3) / `INn_DIFF1` bit ($n = 1$ or 2). When the input clock validity changes (from 'valid' to 'invalid' or from 'invalid' to 'valid'), the `INn_CMOS2` / `INn_DIFF2` bit will be set. If the `INn_CMOS3` / `INn_DIFF3` bit is '1', an interrupt will be generated.

When the T0 selected input clock has failed, i.e., the validity of the T0 selected input clock changes from 'valid' to 'invalid', the `T0_MAIN_REF_FAILED1` bit will be set. If the `T0_MAIN_REF_FAILED2` bit is '1', an interrupt will be generated. This interrupt can also be indicated by hardware - the TDO pin, as determined by the `LOS_FLAG_TO_TDO` bit. When the TDO pin is used to indicate this interrupt, it will be set high when this interrupt is generated and will remain high until this interrupt is cleared.

3.8.2 SELECTED INPUT CLOCK SWITCH

Revertive and Non-Revertive switches are supported, as selected by the `REVERTIVE_MODE` bit.

The difference between Revertive and Non-Revertive switches is that whether the selected input clock is switched when another qualified input clock with a higher priority than the current selected input clock is

available for selection. In Non-Revertive switch, input clock switch is minimized.

Conditions of the qualified input clocks available for T0 selection are as shown in [Table 13](#):

Table 13: Conditions of Qualified Input Clocks Available for T0 Selection

Conditions of Qualified Input Clocks Available for T0 Selection	
T0	<ul style="list-style-type: none"> • Valid, i.e., the <code>INn_CMOS¹</code> / <code>INn_DIFF¹</code> bit is '1'; • Priority enabled, i.e., the corresponding <code>INn_CMOS_SEL_PRIORITY[3:0]</code> / <code>INn_DIFF_SEL_PRIORITY[3:0]</code> bits are not '0000'

The input clock is disqualified if any of the above conditions is not satisfied.

In summary, the selected input clock can be switched by:

- External Fast selection;
- Forced selection;
- Revertive switch;
- Non-Revertive switch;

3.8.2.1 Revertive Switch

In Revertive switch, the selected input clock is switched when another qualified input clock with a higher priority than the current selected input clock is available.

The selected input clock is switched if any of the following is satisfied:

- the selected input clock is disqualified;
- another qualified input clock with a higher priority than the selected input clock is available.

A qualified input clock with the highest priority is selected by revertive switch. If more than one qualified input clock is available and has the same priority, the input clock with the smallest 'n' is selected. See [Table 8](#) for the 'n' assigned to each input clock.

3.8.2.2 Non-Revertive Switch

In Non-Revertive switch, the T0 selected input clock is not switched when another qualified input clock with a higher priority than the current selected input clock is available. In this case, the selected input clock is switched and a qualified input clock with the highest priority is selected only when the T0 selected input clock is disqualified. If more than one qualified input clock is available and has the same priority, the input clock with the smallest 'n' is selected. See [Table 8](#) for the 'n' assigned to each input clock.

3.8.3 SELECTED / QUALIFIED INPUT CLOCKS INDICATION

The selected input clock is indicated by the `CURRENTLY_SELECTED_INPUT[3:0]` bits.

The qualified input clocks with the three highest priorities are indicated by `HIGHEST_PRIORITY_VALIDATED[3:0]` bits, the `SECOND_PRIORITY_VALIDATED[3:0]` bits and the `THIRD_PRIORITY_VALIDATED[3:0]` bits respectively. If more than one input clock has the same priority, the input clock with the smallest 'n' is indicated by the

HIGHEST_PRIORITY_VALIDATED[3:0] bits. See [Table 8](#) for the 'n' assigned to the input clock.

When the device is configured in Automatic selection and Revertive switch is enabled, the input clock indicated by the

CURRENTLY_SELECTED_INPUT[3:0] bits is the same as the one indicated by the HIGHEST_PRIORITY_VALIDATED[3:0] bits; otherwise, they are not the same.

Table 14: Related Bit / Register in Chapter 3.8

Bit	Register	Address (Hex)
INn_CMOS ¹ (n = 1, 2 or 3) / INn_DIFF ¹ (n = 1 or 2)	INPUT_VALID1_STS, INPUT_VALID2_STS	4A, 4B
INn_CMOS ² (n = 1, 2 or 3) / INn_DIFF ² (n = 1 or 2)	INTERRUPTS1_STS, INTERRUPTS2_STS	0D, 0E
INn_CMOS ³ (n = 1, 2 or 3) / INn_DIFF ³ (n = 1 or 2)	INTERRUPTS1_ENABLE_CNFG, INTERRUPTS2_ENABLE_CNFG	10, 11
INn_CMOS_NO_ACTIVITY_ALARM (n = 1, 2 or 3)	IN1_IN2_CMOS_STS, IN3_CMOS_STS	44, 47
INn_CMOS_FREQ_HARD_ALARM (n = 1, 2 or 3)		
INn_CMOS_PH_LOCK_ALARM (n = 1, 2 or 3)		
INn_DIFF_NO_ACTIVITY_ALARM (n = 1 or 2)	IN1_IN2_DIFF_STS	45
INn_DIFF_FREQ_HARD_ALARM (n = 1 or 2)		
INn_DIFF_PH_LOCK_ALARM (n = 1 or 2)		
IN_NOISE_WINDOW	PHASE_MON_PBO_CNFG	78
ULTR_FAST_SW	MON_SW_PBO_CNFG	0B
LOS_FLAG_TO_TDO		
T0_MAIN_REF_FAILED ¹	INTERRUPTS2_STS	0E
T0_MAIN_REF_FAILED ²	INTERRUPTS2_ENABLE_CNFG	11
REVERTIVE_MODE	INPUT_MODE_CNFG	09
INn_CMOS_SEL_PRIORITY[3:0] (n = 1, 2 or 3)	IN1_IN2_CMOS_SEL_PRIORITY_CNFG, IN3_CMOS_SEL_PRIORITY_CNFG	27 *, 2A *
INn_DIFF_SEL_PRIORITY[3:0] (n = 1 or 2)	IN1_IN2_DIFF_SEL_PRIORITY_CNFG	28 *
CURRENTLY_SELECTED_INPUT[3:0]	PRIORITY_TABLE1_STS	4E *
HIGHEST_PRIORITY_VALIDATED[3:0]		
SECOND_PRIORITY_VALIDATED[3:0]		
THIRD_PRIORITY_VALIDATED[3:0]	PRIORITY_TABLE2_STS	4F *

3.9 SELECTED INPUT CLOCK STATUS VS. DPLL OPERATING MODE

T0 DPLL supports three primary operating modes: Free-Run, Locked and Holdover, and three secondary, temporary operating modes: Pre-Locked, Pre-Locked2 and Lost-Phase.

When the operating mode is switched by force, the operating mode switch is under external control and the status of the selected input clock takes no effect to the operating mode selection. The forced operating mode switch is applicable for special cases, such as testing.

When the operating mode is switched automatically, the internal state machines for T0 automatically determine the operating mode respectively.

3.9.1 T0 SELECTED INPUT CLOCK VS. DPLL OPERATING MODE

The T0 DPLL operating mode is controlled by the T0_OPERATING_MODE[2:0] bits, as shown in Table 15:

Table 15: T0 DPLL Operating Mode Control

T0_OPERATING_MODE[2:0]	T0 DPLL Operating Mode
000	Automatic
001	Forced - Free-Run
010	Forced - Holdover
100	Forced - Locked
101	Forced - Pre-Locked2
110	Forced - Pre-Locked
111	Forced - Lost-Phase

When the operating mode is switched automatically, the operation of the internal state machine is shown in Figure 6.

Whether the operating mode is under external control or is switched automatically, the current operating mode is always indicated by the T0_DPLL_OPERATING_MODE[2:0] bits. When the operating mode switches, the T0_OPERATING_MODE¹ bit will be set. If the T0_OPERATING_MODE² bit is '1', an interrupt will be generated.

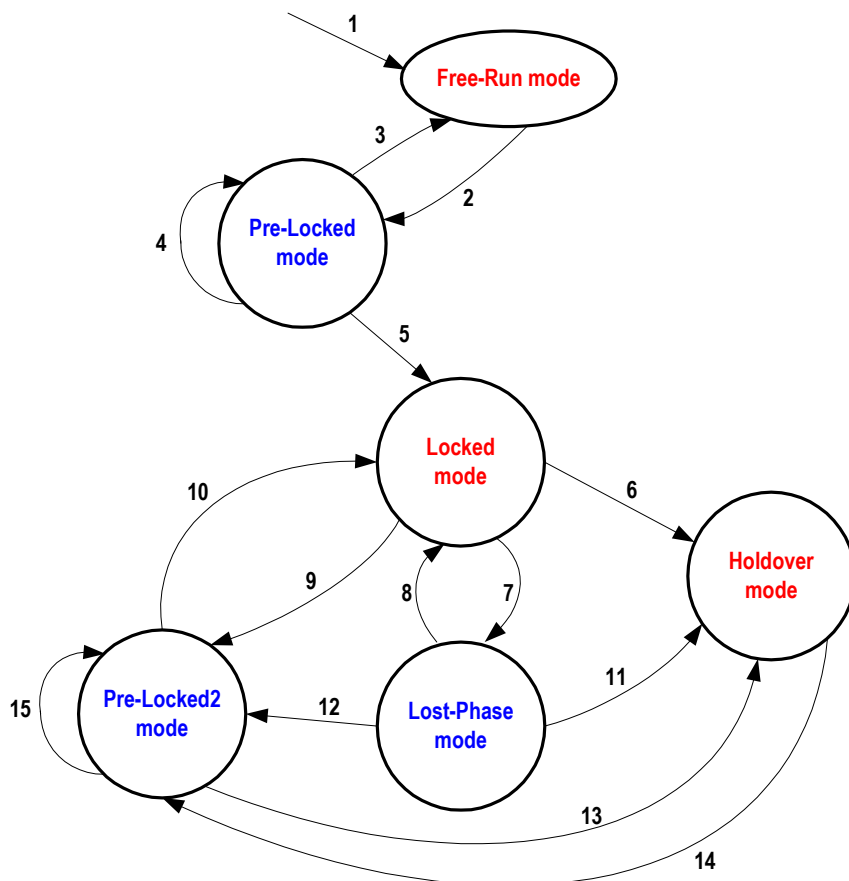

Figure 6. T0 Selected Input Clock vs. DPLL Automatic Operating Mode

Notes to [Figure 6](#):

1. Reset.
2. An input clock is selected.
3. The T0 selected input clock is disqualified **AND** No qualified input clock is available.
4. The T0 selected input clock is switched to another one.
5. The T0 selected input clock is locked (the T0_DPLL_LOCK bit is '1').
6. The T0 selected input clock is disqualified **AND** No qualified input clock is available.
7. The T0 selected input clock is unlocked (the T0_DPLL_LOCK bit is '0').
8. The T0 selected input clock is locked again (the T0_DPLL_LOCK bit is '1').
9. The T0 selected input clock is switched to another one.
10. The T0 selected input clock is locked (the T0_DPLL_LOCK bit is '1').
11. The T0 selected input clock is disqualified **AND** No qualified input clock is available.
12. The T0 selected input clock is switched to another one.
13. The T0 selected input clock is disqualified **AND** No qualified input clock is available.
14. An input clock is selected.
15. The T0 selected input clock is switched to another one.

The causes of Item 4, 9, 12, 15 - 'the T0 selected input clock is switched to another one' - are: (The T0 selected input clock is disqualified **AND** Another input clock is switched to) **OR** (In Revertive switch, a qualified input clock with a higher priority is switched to) **OR** (The T0 selected input clock is switched to another one by External Fast selection or Forced selection).

Refer to [Table 13](#) for details about the input clock qualification for T0 path.

3.10 DPLL OPERATING MODE

The DPLL gives a stable performance in different applications without being affected by operating conditions or silicon process variations. It integrates a PFD (Phase & Frequency Detector), a LPF (Low Pass Filter) and a DCO (Digital Controlled Oscillator), which forms a closed loop. If no input clock is selected, the loop is not closed, and the PFD and LPF do not function.

The PFD detects the phase error, including the fast loss, coarse phase loss and fine phase loss (refer to [Chapter 3.7.1.1 Fast Loss](#) to [Chapter 3.7.1.3 Fine Phase Loss](#)). The averaged phase error of the DPLL feedback with respect to the selected input clock is indicated by the CURRENT_PH_DATA[15:0] bits. It can be calculated as follows:

$$\text{Averaged Phase Error (ns)} = \text{CURRENT_PH_DATA}[15:0] \times 0.61$$

The LPF filters jitters. Its 3 dB bandwidth and damping factor are programmable. A range of bandwidths and damping factors can be set to meet different application requirements. Generally, the lower the damping factor is, the longer the locking time is and the more the gain is.

The DCO controls the DPLL output. The frequency of the DPLL output is always multiplied on the basis of the master clock. The phase and frequency offset of the DPLL output may be locked to those of the selected input clock. The current frequency offset with respect to the master clock is indicated by the CURRENT_DPLL_FREQ[23:0] bits, and can be calculated as follows:

$$\text{Current Frequency Offset (ppm)} = \text{CURRENT_DPLL_FREQ}[23:0] \times 0.000011$$

3.10.1 T0 DPLL OPERATING MODE

The T0 DPLL loop is closed except in Free-Run mode and Holdover mode.

For a closed loop, different bandwidths and damping factors can be used depending on DPLL locking stages: starting, acquisition and locked.

In the first two seconds when the T0 DPLL attempts to lock to the selected input clock, the starting bandwidth and damping factor are used. They are set by the T0_DPLL_START_BW[4:0] bits and the T0_DPLL_START_DAMPING[2:0] bits respectively.

During the acquisition, the acquisition bandwidth and damping factor are used. They are set by the T0_DPLL_ACQ_BW[4:0] bits and the T0_DPLL_ACQ_DAMPING[2:0] bits respectively.

When the T0 selected input clock is locked, the locked bandwidth and damping factor are used. They are set by the T0_DPLL_LOCKED_BW[4:0] bits and the T0_DPLL_LOCKED_DAMPING[2:0] bits respectively.

The corresponding bandwidth and damping factor are used when the T0 DPLL operates in different DPLL locking stages: starting, acquisition and locked, as controlled by the device automatically.

Only the locked bandwidth and damping factor can be used regardless of the T0 DPLL locking stage, as controlled by the AUTO_BW_SEL bit.

3.10.1.1 Free-Run Mode

In Free-Run mode, the T0 DPLL output refers to the master clock and is not affected by any input clock. The accuracy of the T0 DPLL output is equal to that of the master clock.

3.10.1.2 Pre-Locked Mode

In Pre-Locked mode, the T0 DPLL output attempts to track the selected input clock.

The Pre-Locked mode is a secondary, temporary mode.

3.10.1.3 Locked Mode

In Locked mode, the T0 selected input clock is locked. The phase and frequency offset of the T0 DPLL output track those of the T0 selected input clock.

In this mode, if the T0 selected input clock is in fast loss status and the FAST_LOS_SW bit is '1', the T0 DPLL is unlocked (refer to [Chapter 3.7.1.1 Fast Loss](#)) and will enter Lost-Phase mode when the operating mode is switched automatically; if the T0 selected input clock is in fast loss status and the FAST_LOS_SW bit is '0', the T0 DPLL locking status is not affected and the T0 DPLL will enter Temp-Holdover mode automatically.

3.10.1.3.1 Temp-Holdover Mode

The T0 DPLL will automatically enter Temp-Holdover mode with a selected input clock switch or no qualified input clock available when the operating mode switch is under external control.

In Temp-Holdover mode, the T0 DPLL has temporarily lost the selected input clock. The T0 DPLL operation in Temp-Holdover mode and that in Holdover mode are alike (refer to [Chapter 3.10.1.5 Holdover Mode](#)) except the frequency offset acquiring methods. See [Chapter 3.10.1.5 Holdover Mode](#) for details about the methods. The method is selected by the TEMP_HOLDOVER_MODE[1:0] bits, as shown in [Table 16](#):

Table 16: Frequency Offset Control in Temp-Holdover Mode

TEMP_HOLDOVER_MODE[1:0]	Frequency Offset Acquiring Method
00	the same as that used in Holdover mode
01	Automatic Instantaneous
10	Automatic Fast Averaged
11	Automatic Slow Averaged

The device automatically controls the T0 DPLL to exit from Temp-Holdover mode.

3.10.1.4 Lost-Phase Mode

In Lost-Phase mode, the T0 DPLL output attempts to track the selected input clock.

The Lost-Phase mode is a secondary, temporary mode.

3.10.1.5 Holdover Mode

In Holdover mode, the T0 DPLL resorts to the stored frequency data acquired in Locked mode to control its output. The T0 DPLL output is not

phase locked to any input clock. The frequency offset acquiring method is selected by the MAN_HOLD OVER bit, the AUTO_AVG bit and the FAST_AVG bit, as shown in [Table 17](#):

Table 17: Frequency Offset Control in Holdover Mode

MAN_HOLD OVER	AUTO_AVG	FAST_AVG	Frequency Offset Acquiring Method
0	0	don't-care	Automatic Instantaneous
	1	0	Automatic Slow Averaged
		1	Automatic Fast Averaged
1	don't-care		Manual

3.10.1.5.1 Automatic Instantaneous

By this method, the T0 DPLL freezes at the operating frequency when it enters Holdover mode. The accuracy is 4.4×10^{-8} ppm.

3.10.1.5.2 Automatic Slow Averaged

By this method, an internal IIR (Infinite Impulse Response) filter is employed to get the frequency offset. The IIR filter gives a 3 dB attenuation point corresponding to a period of 110 minutes. The accuracy is 1.1×10^{-5} ppm.

3.10.1.5.3 Automatic Fast Averaged

By this method, an internal IIR (Infinite Impulse Response) filter is employed to get the frequency offset. The IIR filter gives a 3 dB attenuation point corresponding to a period of 8 minutes. The accuracy is 1.1×10^{-5} ppm.

3.10.1.5.4 Manual

By this method, the frequency offset is set by the T0_HOLD OVER_FREQ[23:0] bits. The accuracy is 1.1×10^{-5} ppm.

The frequency offset of the T0 DPLL output is indicated by the CURRENT_DPLL_FREQ[23:0] bits.

The device provides a reference for the value to be written to the T0_HOLD OVER_FREQ[23:0] bits. The value to be written can refer to the value read from the CURRENT_DPLL_FREQ[23:0] bits or the T0_HOLD OVER_FREQ[23:0] bits (refer to [Chapter 3.10.1.5.5 Holdover](#)

[Frequency Offset Read](#)); or then be processed by external software filtering.

3.10.1.5.5 Holdover Frequency Offset Read

The offset value, which is acquired by Automatic Slow Averaged, Automatic Fast Averaged and is set by related register bits, can be read from the T0_HOLD OVER_FREQ[23:0] bits by setting the READ_AVG bit and the FAST_AVG bit, as shown in [Table 18](#).

Table 18: Holdover Frequency Offset Read

READ_AVG	FAST_AVG	Offset Value Read from T0_HOLD OVER_FREQ[23:0]
0	don't-care	The value is equal to the one written to.
1	0	The value is acquired by Automatic Slow Averaged method, not equal to the one written to.
	1	The value is acquired by Automatic Fast Averaged method, not equal to the one written to.

The frequency offset in ppm is calculated as follows:

$$\text{Holdover Frequency Offset (ppm)} = T0_HOLD OVER_FREQ[23:0] \times 0.000011$$

3.10.1.6 Pre-Locked2 Mode

In Pre-Locked2 mode, the T0 DPLL output attempts to track the selected input clock.

The Pre-Locked2 mode is a secondary, temporary mode.

3.11 DPLL OUTPUT

The DPLL output is locked to the selected input clock. According to the phase-compared result of the feedback and the selected input clock, and the DPLL output frequency offset, the PFD output is limited and the DPLL output is frequency offset limited.

3.11.1 PFD OUTPUT LIMIT

The PFD output is limited to be within ± 1 UI or within the coarse phase limit (refer to [Chapter 3.7.1.2 Coarse Phase Loss](#)), as determined by the MULTI_PH_APP bit.

3.11.2 FREQUENCY OFFSET LIMIT

The DPLL output is limited to be within the DPLL hard limit (refer to [Chapter 3.7.1.4 Hard Limit Exceeding](#)).

For T0 DPLL, the integral path value can be frozen when the DPLL hard limit is reached. This function, enabled by the T0_LIMT bit, will minimize the subsequent overshoot when T0 DPLL is pulling in.

3.11.3 PBO

The PBO function is only supported by the T0 path.

When a PBO event is triggered, the phase offset of the selected input clock with respect to the T0 DPLL output is measured. The device then automatically accounts for the measured phase offset and compensates an appropriate phase offset into the DPLL output so that the phase transients on the T0 DPLL output are minimized.

A PBO event is triggered if any one of the following conditions occurs:

- T0 selected input clock switches (the PBO_EN bit is '1');
- T0 DPLL exits from Holdover mode or Free-Run mode (the PBO_EN bit is '1');
- Phase-time changes on the T0 selected input clock are greater than a programmable limit over an interval of less than 0.1 seconds (the PH_MON_PBO_EN bit is '1').

For the first two conditions, the phase transients on the T0 DPLL output are minimized to be no more than 0.61 ns with PBO. The PBO can also be frozen at the current phase offset by setting the PBO_FREZ bit. When the PBO is frozen, the device will ignore any further PBO events triggered by the above two conditions, and maintain the current phase offset. When the PBO is disabled, there may be a phase shift on the T0 DPLL output and the T0 DPLL output tracks back to 0 degree phase offset with respect to the T0 selected input clock.

The last condition is specially for stratum 2 and 3E clocks. The PBO requirement specified in the Telcordia GR-1244-CORE is: 'Input phase-time changes of 3.5 μ s or greater over an interval of less than 0.1 seconds or less shall be built-out by stratum 2 and 3E clocks to reduce the resulting clock phase-time change to less than 50 ns. Phase-time

changes of 1.0 μ s or less over an interval of 0.1 seconds shall not be built-out.' Based on this requirement, phase-time changes of more than 1.0 μ s but less than 3.5 μ s that occur over an interval of less than 0.1 seconds may or may not be built-out.

An integrated Phase Transient Monitor can be enabled by the PH_MON_EN bit to monitor the phase-time changes on the T0 selected input clock. When the phase-time changes are greater than a limit over an interval of less than 0.1 seconds, a PBO event is triggered and the phase transients on the DPLL output are absorbed. The limit is programmed by the PH_TR_MON_LIMT[3:0] bits, and can be calculated as follows:

$$\text{Limit (ns)} = (\text{PH_TR_MON_LIMT}[3:0] + 7) \times 156$$

The phase offset induced by PBO will never result in a coarse or fine phase loss.

3.11.4 PHASE OFFSET SELECTION

The phase offset of the T0 selected input clock with respect to the T0 DPLL output can be adjusted. The PH_OFFSET_EN bit determines whether the input-to-output phase offset is enabled. If enabled, the input-to-output phase offset can be adjusted by setting the PH_OFFSET[9:0] bits.

The input-to-output phase offset can be calculated as follows:

$$\text{Phase Offset (ns)} = \text{PH_OFFSET}[9:0] \times 0.61$$

3.11.5 FOUR PATHS OF T0 DPLL OUTPUTS

The T0 DPLL output are phase aligned with the T0 selected input clock respectively every 125 μ s period. Each DPLL has four output paths.

3.11.5.1 T0 Path

The four paths for T0 DPLL output are as follows:

- 77.76 MHz path - outputs a 77.76 MHz clock;
- 16E1/16T1 path - outputs a 16E1 or 16T1 clock, as selected by the IN_SONET_SDH bit;
- ETH/OBSAI/16E1/16T1 path - outputs a ETH, OBSAI, 16E1 or 16T1 clock, as selected by the T0_ETH_OBSAI_16E1_16T1_SEL[1:0] bits;
- 12E1/24T1/E3/T3 path - outputs a 12E1, 24T1, E3 or T3 clock, as selected by the T0_12E1_24T1_E3_T3_SEL[1:0] bits.

T0 selected input clock is compared with a T0 DPLL output for DPLL locking. The output can only be derived from the 77.76 MHz path or the 16E1/16T1 path. The output path is automatically selected and the output is automatically divided to get the same frequency as the T0 selected input clock.

T0 DPLL outputs are provided for T0/T4 APLL or device output process.

3.12 T0 / T4 APLL

A T0 APLL and a T4 APLL are provided for a better jitter and wander performance of the device output clocks.

The bandwidths of the T0/T4 APLL are set by the T0_APLL_BW[1:0] / T4_APLL_BW[1:0] bits respectively. The lower the bandwidth is, the better the jitter and wander performance of the T0/T4 APLL output are.

The input of the T0/T4 APLL can be derived from the T0 DPLL outputs, as selected by the T0_APLL_PATH[3:0] / T4_APLL_PATH[3:0] bits respectively.

Both the APLL and DPLL outputs are provided for selection for the device output.

Table 19: Related Bit / Register in Chapter 3.12

Bit	Register	Address (Hex)
T0_APLL_BW[1:0]	T0_T4_APLL_BW_CNFG	6A
T4_APLL_BW[1:0]		
T0_APLL_PATH[3:0]	T0_DPLL_APLL_PATH_CNFG	55
T4_APLL_PATH[3:0]	DPLL_APLL_PATH_CNFG	60

3.13 OUTPUT CLOCKS & FRAME SYNC SIGNALS

The device supports 2 output clocks and 2 frame sync output signals altogether.

3.13.1 OUTPUT CLOCKS

The device provides 2 output clocks.

OUT1 outputs a PECL or LVDS signal, as selected by the OUT1_PECL_LVDS bit. OUT2 outputs a CMOS signal.

The outputs on OUT1 and OUT2 are variable, depending on the signals derived from the T0 DPLL and T0/T4 APLL outputs, and the corresponding OUTn_PATH_SEL[3:0] bits (n = 1 or 2). The derived signal can be from the T0 DPLL and T0/T4 APLL outputs, as selected by the corresponding OUTn_PATH_SEL[3:0] bits (n = 1 or 2). If the signal is derived from one of the T0 DPLL outputs, please refer to [Table 20](#) for the output frequency. If the signal is derived from the T0/T4 APLL output, please refer to [Table 21~Table 22](#) for the output frequency.

The outputs on OUT1 and OUT2 can be inverted, as determined by the corresponding OUTn_INV bit (n = 1 or 2).

Both the output clocks derived from T0/T4 selected input clock are aligned with the T0/T4 selected input clock respectively every 125 μ s period.

Table 20: Outputs on OUT1 & OUT2 if Derived from T0 DPLL Outputs

OUTn_DIVIDER[3:0] (Output Divider) ¹	outputs on OUT1 & OUT2 if derived from T0 DPLL outputs ²									
	77.76 MHz	12E1	16E1	24T1	16T1	E3	T3	GSM (26 MHz)	OBSAI (30.72 MHz)	GPS (40 MHz)
0000	Output is disabled (output low).									
0001										
0010		12E1	16E1	24T1	16T1	E3	T3			
0011		6E1	8E1	12T1	8T1			13 MHz	15.36 MHz	20
0100		3E1	4E1	6T1	4T1					10
0101		2E1		4T1						
0110			2E1	3T1	2T1					5
0111		E1		2T1						
1000			E1		T1					
1001				T1						
1010	64 kHz									
1011	8 kHz									
1100	2 kHz									
1101	400 Hz									
1110	1Hz									
1111	Output is disabled (output high).									

Note:

1. n = 1 or 2. Each output is assigned a frequency divider.

2. E1 = 2.048 MHz, T1 = 1.544 MHz, E3 = 34.368 MHz, T3 = 44.736 MHz. The blank cell means the configuration is reserved.

Table 21: Outputs on OUT1 & OUT2 if Derived from T0 APLL

OUTn_DIVIDER[3:0] (Output Divider) ¹	outputs on OUT1 & OUT2 if derived from T0 APLL output ²									
	77.76 MHz X 4	12E1 X 4	16E1 X 4	24T1 X 4	16T1 X 4	E3	T3	GSM (26 MHz X 2)	OBSAI (30.72 MHz X 10)	GPS (40 MHz)
0000	Output is disabled (output low).									
0001	622.08 MHz ³									
0010	311.04 MHz ³	48E1	64E1	96T1	64T1	E3	T3	52 MHz		
0011	155.52 MHz	24E1	32E1	48T1	32T1			26 MHz	153.6 MHz	20 MHz
0100	77.76 MHz	12E1	16E1	24T1	16T1			13 MHz	76.8 MHz	10 MHz
0101	51.84 MHz	8E1		16T1						
0110	38.88 MHz	6E1	8E1	12T1	8T1				38.4 MHz	5 MHz
0111	25.92 MHz	4E1		8T1						
1000	19.44 MHz	3E1	4E1	6T1	4T1					
1001		2E1		4T1					61.44 MHz	
1010			2E1	3T1	2T1				30.72 MHz	
1011	6.48 MHz	E1		2T1					15.36 MHz	
1100			E1		T1				7.68 MHz	
1101				T1					3.84 MHz	
1110										
1111	Output is disabled (output high).									

Note:
1. n = 1 or 2. Each output is assigned a frequency divider.
2. In the APLL, the selected T0 DPLL output may be multiplied. E1 = 2.048 MHz, T1 = 1.544 MHz, E3 = 34.368 MHz, T3 = 44.736 MHz. The blank cell means the configuration is reserved.
3. The 622.08 MHz and 311.04 MHz differential signals are only output on OUT1.

Table 22: Outputs on OUT1 & OUT2 if Derived from T4 APLL

OUTn_DIVIDER[3:0] (Output Divider) ¹	outputs on OUT1 & OUT2 if derived from T4 APLL output ²										
	77.76 MHz X 4	12E1 X 4	16E1 X 4	24T1 X 4	16T1 X 4	E3	T3	GSM (26 MHz X 2)	ETH	OBSAI (30.72 MHz X 10)	GPS (40 MHz)
0000	Output is disabled (output low).										
0001	622.08 MHz ³										
0010	311.04 MHz ³	48E1	64E1	96T1	64T1	E3	T3	52 MHz	312.5 MHz		
0011	155.52 MHz	24E1	32E1	48T1	32T1			26 MHz	156.25 MHz	153.6 MHz	20 MHz
0100	77.76 MHz	12E1	16E1	24T1	16T1			13 MHz		76.8 MHz	10 MHz
0101	51.84 MHz	8E1		16T1							
0110	38.88 MHz	6E1	8E1	12T1	8T1					38.4 MHz	5 MHz
0111	25.92 MHz	4E1		8T1							
1000	19.44 MHz	3E1	4E1	6T1	4T1				125 MHz		
1001		2E1		4T1					25 MHz		
1010			2E1	3T1	2T1				5 MHz		
1011	6.48 MHz	E1		2T1							
1100			E1		T1				62.5 MHz		
1101				T1							
1110											
1111	Output is disabled (output high).										

Note:
1. n = 1 or 2. Each output is assigned a frequency divider.
2. In the APLL, the selected T0 DPLL output may be multiplied. E1 = 2.048 MHz, T1 = 1.544 MHz, E3 = 34.368 MHz, T3 = 44.736 MHz. The blank cell means the configuration is reserved.
3. The 622.08 MHz and 311.04 MHz differential signals are only output on OUT1.

3.13.2 FRAME SYNC OUTPUT SIGNALS

An 8 kHz and a 2 kHz frame sync signals are output on the FRSYNC_8K and MFRSYNC_2K pins if enabled by the 8K_EN and 2K_EN bits respectively. They are CMOS outputs.

The two frame sync signals are derived from the T0 APLL output and are aligned with the output clock. They can be synchronized to one of the three frame sync input signals.

One of the three frame sync input signals is selected, as determined by the SYNC_BYPASS bit and the T0 selected input clock, as shown in Table 23:

Table 23: Frame Sync Input Signal Selection

SYNC_BYPASS	T0 Selected Input Clock	Selected Frame Sync Input Signal
0	don't-care	EX_SYNC1
1	IN1_CMOS or IN1_DIFF	EX_SYNC1
	IN2_CMOS or IN2_DIFF	EX_SYNC2
	IN3_CMOS	EX_SYNC3
	none	none

If the selected frame sync input signal with respect to the T0 selected input clock is above a limit set by the SYNC_MON_LIMT[2:0] bits, an external sync alarm will be raised and the selected frame sync input signal is disabled to synchronize the frame sync output signals. The external sync alarm is cleared once the selected frame sync input signal with respect to the T0 selected input clock is within the limit. If it is within the

Table 24: Synchronization Control

SYNC_BYPASS	AUTO_EXT_SYNC_EN	EXT_SYNC_EN	Synchronization
0	don't-care	0	Disabled
	0	1	Enabled
	1	1	Disabled
1	don't-care		Enabled

limit, whether the selected frame sync input signal is enabled to synchronize the frame sync output signal is determined by the SYNC_BYPASS bit, the AUTO_EXT_SYNC_EN bit and the EXT_SYNC_EN bit. Refer to Table 24 for details.

When the selected frame sync input signal is enabled to synchronize the frame sync output signal, it should be adjusted to align itself with the T0 selected input clock. Nominally, the falling edge of the selected frame sync input signal is aligned with the rising edge of the T0 selected input clock. The selected frame sync input signal may be 0.5 UI early/late or 1 UI late due to the circuit and board wiring delays. Setting the sampling of the selected frame sync input signal by the SYNC_PHN[1:0] bits (n = 1, 2 or 3 corresponding to EX_SYNC1, EX_SYNC2 or EX_SYNC3 respectively) will compensate this early/late. Refer to Figure 7 to Figure 10.

The EX_SYNC_ALARM_MON bit indicates whether the selected frame sync input signal is in external sync alarm status. The external sync alarm is indicated by the EX_SYNC_ALARM¹ bit. If the EX_SYNC_ALARM² bit is '1', the occurrence of the external sync alarm will trigger an interrupt.

The 8 kHz and the 2 kHz frame sync output signals can be inverted by setting the 8K_INV and 2K_INV bits respectively. The frame sync outputs can be 50:50 duty cycle or pulsed, as determined by the 8K_PUL and 2K_PUL bits respectively. When they are pulsed, the pulse width is defined by the period of OUT2; and they are pulsed on the position of the falling or rising edge of the standard 50:50 duty cycle, as selected by the 2K_8K_PUL_POSITION bit.

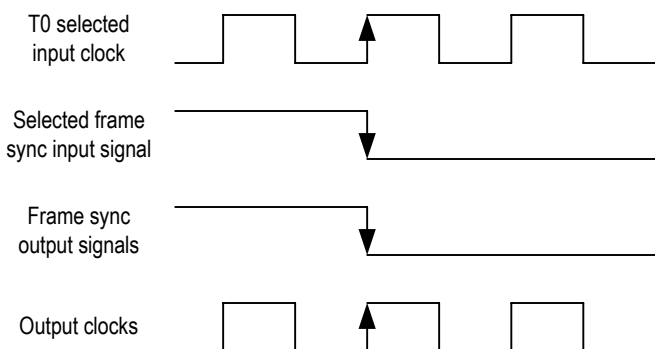

Figure 7. On Target Frame Sync Input Signal Timing

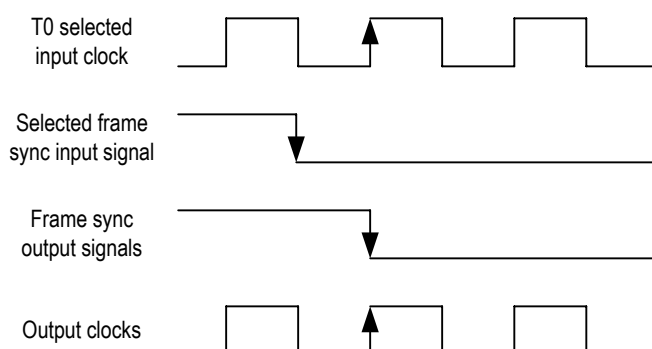

Figure 8. 0.5 UI Early Frame Sync Input Signal Timing

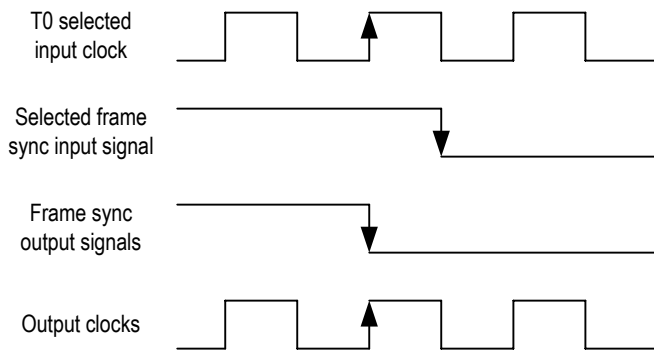

Figure 9. 0.5 UI Late Frame Sync Input Signal Timing

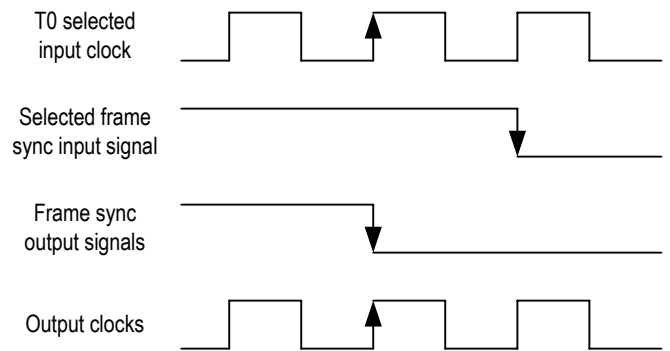

Figure 10. 1 UI Late Frame Sync Input Signal Timing

Table 25: Related Bit / Register in Chapter 3.13

Bit	Register	Address (Hex)
OUT1_PECL_LVDS	DIFFERENTIAL_IN_OUT_OSCI_CNFG	0A
OUTn_PATH_SEL[3:0] (n = 1 or 2)	OUT1_FREQ_CNFG, OUT2_FREQ_CNFG	71, 6D
OUTn_DIVIDER[3:0] (n = 1 or 2)		
IN_SONET_SDH	INPUT_MODE_CNFG	09
AUTO_EXT_SYNC_EN		
EXT_SYNC_EN		
OUTn_INV (n = 1 or 2)	OUT1_INV_CNFG, OUT2_INV_CNFG	73, 72
8K_EN	FR_MFR_SYNC_CNFG	74
2K_EN		
8K_INV		
2K_INV		
8K_PUL		
2K_PUL		
2K_8K_PUL_POSITION		
SYNC_BYPASS	SYNC_MONITOR_CNFG	7C
SYNC_MON_LIMIT[2:0]		
SYNC_PHn[1:0] (n = 1, 2 or 3)	SYNC_PHASE_CNFG	7D
EX_SYNC_ALARM_MON	OPERATING_STS	52
EX_SYNC_ALARM ¹	INTERRUPTS3_STS	0F
EX_SYNC_ALARM ²	INTERRUPTS3_ENABLE_CNFG	12

3.14 INTERRUPT SUMMARY

The interrupt sources of the device are as follows:

- Input clocks for T0 path validity change
- T0 selected input clock fail
- T0 DPLL operating mode switch
- External sync alarm

All of the above interrupt events are indicated by the corresponding interrupt status bit. If the corresponding interrupt enable bit is set, any of the interrupts can be reported by the INT_REQ pin. The output characteristics on the INT_REQ pin are determined by the HZ_EN bit and the INT_POL bit.

Interrupt events are cleared by writing a '1' to the corresponding interrupt status bit. The INT_REQ pin will be inactive only when all the pending enabled interrupts are cleared.

In addition, the interrupt of T0 selected input clock fail can be reported by the TDO pin, as determined by the LOS_FLAG_TO_TDO bit.

Table 26: Related Bit / Register in Chapter 3.14

Bit	Register	Address (Hex)
HZ_EN	INTERRUPT_CNFG	0C
INT_POL		
LOS_FLAG_TO_TDO	MON_SW_PBO_CNFG	0B

3.15 T0 SUMMARY

The main features supported by the T0 path are as follows:

- Phase lock alarm;
- Forced or Automatic input clock selection/switch;
- 3 primary and 3 secondary, temporary DPLL operating modes, switched automatically or under external control;
- Automatic switch between starting, acquisition and locked bandwidths/damping factors;
- Programmable DPLL bandwidths from 0.1 Hz to 560 Hz in 11 steps;
- Programmable damping factors: 1.2, 2.5, 5, 10 and 20;
- Fast loss, coarse phase loss, fine phase loss and hard limit exceeding monitoring;
- Output phase and frequency offset limited;
- Automatic Instantaneous, Automatic Slow Averaged, Automatic Fast Averaged or Manual holdover frequency offset acquiring;
- PBO to minimize output phase transients;
- Programmable output phase offset;
- Low jitter multiple clock outputs with programmable polarity;
- Low jitter 2 kHz and 8 kHz frame sync signal outputs with programmable pulse width and polarity.

3.16 POWER SUPPLY FILTERING TECHNIQUES

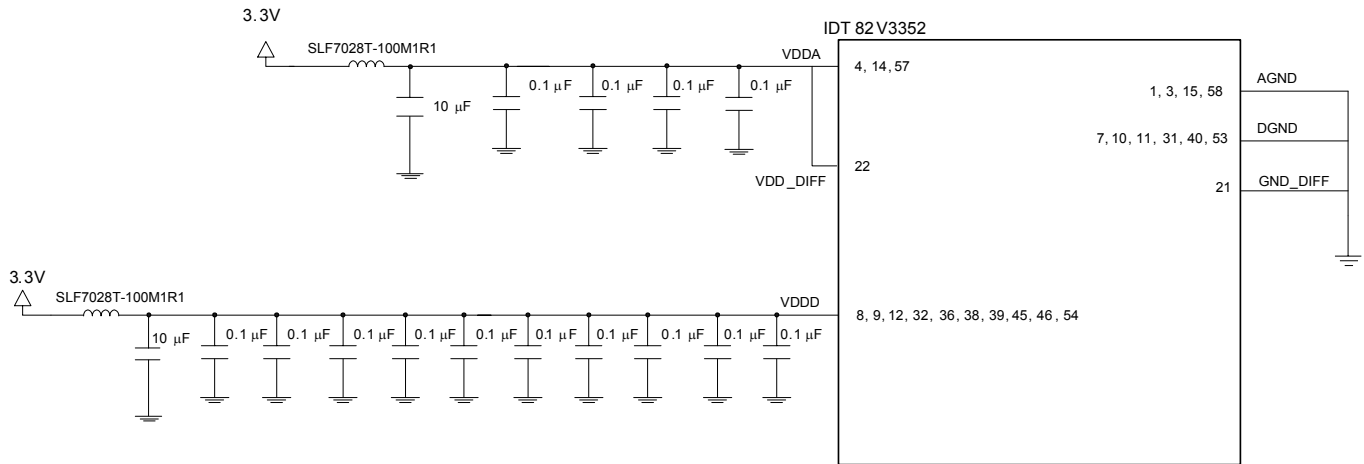

Figure 11. IDT82V3352 Power Decoupling Scheme

To achieve optimum jitter performance, power supply filtering is required to minimize supply noise modulation of the output clocks. The common sources of power supply noise are switch power supplies and the high switching noise from the outputs to the internal PLL. The IDT82V3352 provides separate VDDA power pins for the internal analog PLL, VDD_DIFF for the differential output driver circuit and VDDD pins for the core logic as well as I/O driver circuits.

To minimize switching power supply noise generated by the switching regulator, the power supply output should be filtering with sufficient bulk capacity to minimize ripple and 0.1 uF (0402 case size, ceramic) caps to filter out the switching transients.

For the IDT82V3352, the decoupling for VDDA, VDD_DIFF and VDDD are handled individually. VDDD, VDD_DIFF and VDDA should be individually connected to the power supply plane through vias, and bypass capacitors should be used for each pin. Figure 12 illustrated how bypass capacitor and ferrite bead should be connected to power pins.

The analog power supply VDDA and VDD_DIFF should have low impedance. This can be achieved by using one 10 uF (1210 case size, ceramic) and at least four 0.1 uF (0402 case size, ceramic) capacitors in parallel. The 0.1 uF (0402 case size, ceramic) capacitors must be placed right next to the VDDA and VDD_DIFF pins as close as possible. Note that the 10 uF capacitor must be of 1210 case size, and it must be ceramic for lowest ESR (Effective Series Resistance) possible. The 0.1 uF should be of case size 0402, this offers the lowest ESL (Effective Series Inductance) to achieve low impedance towards the high speed range.

For VDDD, at least ten 0.1 uF (0402 case size, ceramic) and one 10 uF (1210 case size, ceramic) capacitors are recommended. The 0.1 uF capacitors should be placed as close to the VDDD pins as possible.

Please refer to evaluation board schematic for details.

3.17 LINE CARD APPLICATION

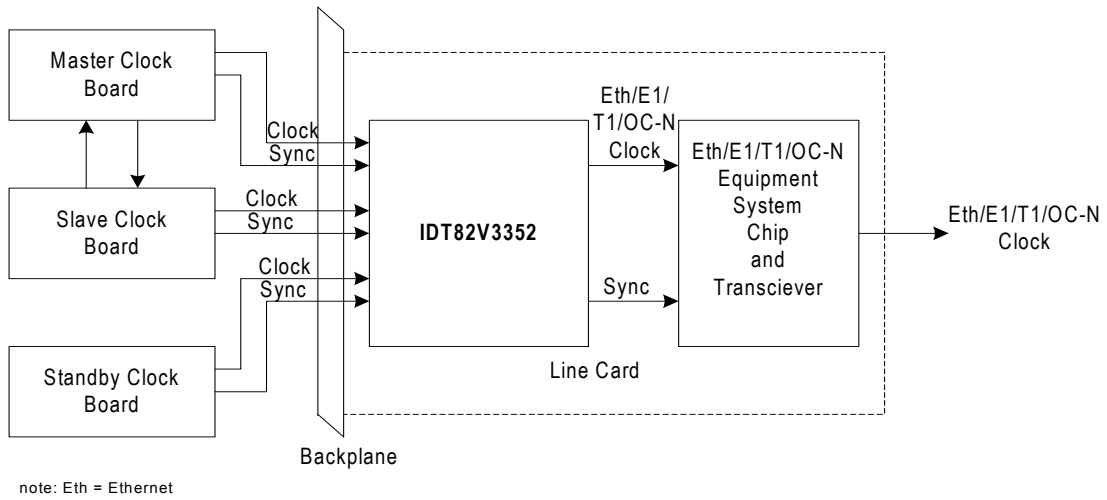

Figure 12. Line Card Application

4 MICROPROCESSOR INTERFACE

The microprocessor interface provides access to read and write the registers in the device. The microprocessor interface supports Serial mode only.

In a read operation, the active edge of SCLK is selected by CLKE. When CLKE is asserted low, data on SDO will be clocked out on the ris-

ing edge of SCLK. When CLKE is asserted high, data on SDO will be clocked out on the falling edge of SCLK.

In a write operation, data on SDI will be clocked in on the rising edge of SCLK.

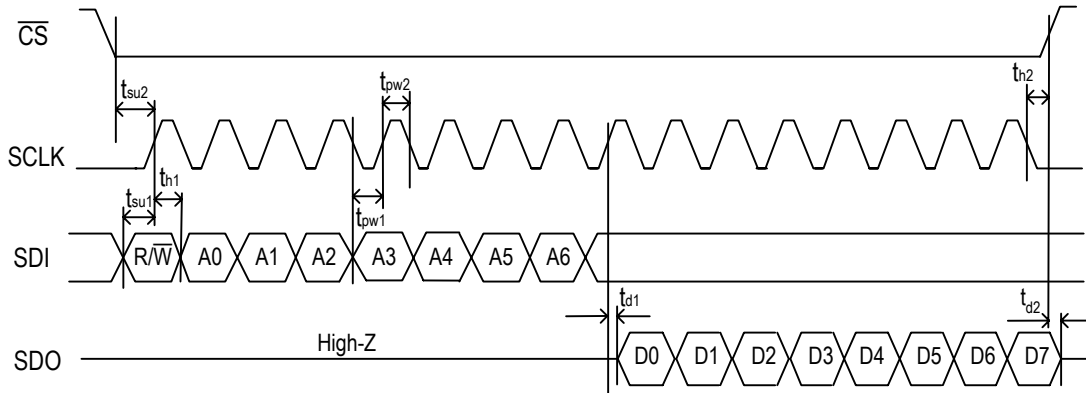

Figure 13. Serial Read Timing Diagram (CLKE Asserted Low)

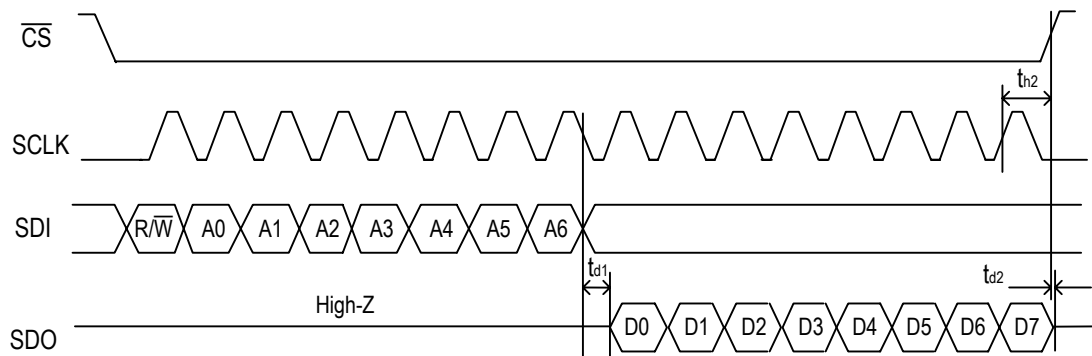

Figure 14. Serial Read Timing Diagram (CLKE Asserted High)

Table 27: Read Timing Characteristics in Serial Mode

Symbol	Parameter	Min	Typ	Max	Unit
T	One cycle time of the master clock		12.86		ns
t _{in}	Delay of input pad		5		ns
t _{out}	Delay of output pad		5		ns
t _{su1}	Valid SDI to valid SCLK setup time	4			ns
t _{su2}	Valid \overline{CS} to valid SCLK setup time	14			ns
t _{d1}	Valid SCLK to valid data delay time		10		ns
t _{d2}	\overline{CS} rising edge to SDO high impedance delay time		10		ns
t _{pw1}	SCLK pulse width low	3.5T + 5			ns
t _{pw2}	SCLK pulse width high	3.5T + 5			ns
t _{h1}	Valid SDI after valid SCLK hold time	6			ns
t _{h2}	Valid \overline{CS} after valid SCLK hold time (CLKE = 0/1)	5			ns
t _{T1}	Time between consecutive Read-Read or Read-Write accesses (\overline{CS} rising edge to \overline{CS} falling edge)	10			ns

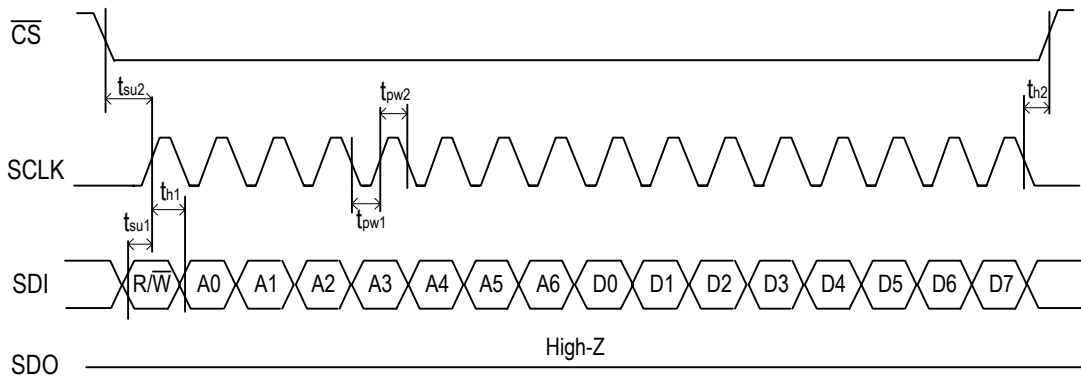

Figure 15. Serial Write Timing Diagram

Table 28: Write Timing Characteristics in Serial Mode

Symbol	Parameter	Min	Typ	Max	Unit
T	One cycle time of the master clock		12.86		ns
t _{in}	Delay of input pad		5		ns
t _{out}	Delay of output pad		5		ns
t _{su1}	Valid SDI to valid SCLK setup time	4			ns
t _{su2}	Valid \overline{CS} to valid SCLK setup time	14			ns
t _{pw1}	SCLK pulse width low	3.5T			ns
t _{pw2}	SCLK pulse width high	3.5T			ns
t _{h1}	Valid SDI after valid SCLK hold time	6			ns
t _{h2}	Valid \overline{CS} after valid SCLK hold time	5			ns
t _{T1}	Time between consecutive Write-Write or Write-Read accesses (\overline{CS} rising edge to \overline{CS} falling edge)	10			ns

5 JTAG

This device is compliant with the IEEE 1149.1 Boundary Scan standard except the following:

- The output boundary scan cells do not capture data from the core and the device does not support EXTEST instruction;
- The $\overline{\text{TRST}}$ pin is set low by default and JTAG is disabled in order to be consistent with other manufacturers.

The JTAG interface timing diagram is shown in [Figure 16](#).

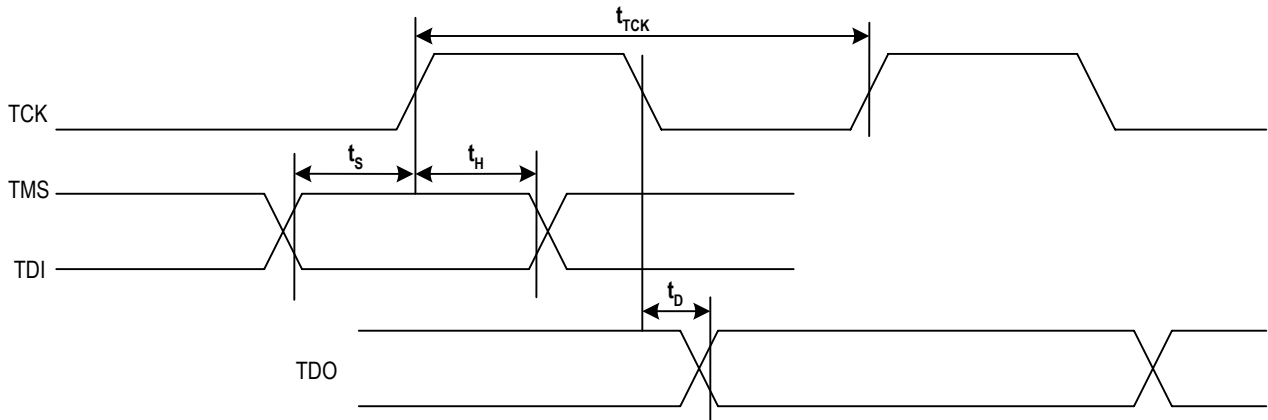

Figure 16. JTAG Interface Timing Diagram

Table 29: JTAG Timing Characteristics

Symbol	Parameter	Min	Typ	Max	Unit
t_{TCK}	TCK period	100			ns
t_s	TMS / TDI to TCK setup time	25			ns
t_H	TCK to TMS / TDI Hold Time	25			ns
t_D	TCK to TDO delay time			50	ns

6 PROGRAMMING INFORMATION

After reset, all the registers are set to their default values. The registers are read or written via the microprocessor interface.

Before any write operation, the value in register PROTECTION_CNFG is recommended to be confirmed to make sure whether the write operation is enabled. The device provides 3 register protection modes:

- Protected mode: no other registers can be written except register PROTECTION_CNFG itself;
- Fully Unprotected mode: all the writable registers can be written;
- Single Unprotected mode: one more register can be written besides register PROTECTION_CNFG. After write operation (not including writing a '1' to clear a bit to '0'), the device automatically switches to Protected mode.

Writing '0' to the registers will take no effect if the registers are cleared by writing '1'.

The access of the Multi-word Registers is different from that of the Single-word Registers. Take the registers (04H, 05H and 06H) for an

example, the write operation for the Multi-word Registers follows a fixed sequence. The register (04H) is configured first and the register (06H) is configured last. The three registers are configured continuously and should not be interrupted by any operation. The crystal calibration configuration will take effect after all the three registers are configured. During read operation, the register (04H) is read first and the register (06H) is read last. The crystal calibration reading should be continuous and not be interrupted by any operation.

Certain bit locations within the device register map are designated as Reserved. To ensure proper and predictable operation, bits designated as Reserved should not be written by the users. In addition, their value should be masked out from any testing or error detection methods that are implemented.

6.1 REGISTER MAP

Table 30 is the map of all the registers, sorted in an ascending order of their addresses.

Table 30: Register List and Map

Address (Hex)	Register Name	Bit 7	Bit 6	Bit 5	Bit 4	Bit 3	Bit 2	Bit 1	Bit 0	Reference Page	
Global Control Registers											
00	ID[7:0] - Device ID 1	ID[7:0]									P 47
01	ID[15:8] - Device ID 2	ID[15:8]									P 47
04	NOMINAL_FREQ[7:0]_CNFG - Crystal Oscillator Frequency Offset Calibration Configuration 1	NOMINAL_FREQ_VALUE[7:0]									P 47
05	NOMINAL_FREQ[15:8]_CNFG - Crystal Oscillator Frequency Offset Calibration Configuration 2	NOMINAL_FREQ_VALUE[15:8]									P 48
06	NOMINAL_FREQ[23:16]_CNFG - Crystal Oscillator Frequency Offset Calibration Configuration 3	NOMINAL_FREQ_VALUE[23:16]									P 48
08	PHASE_ALARM_TIME_OUT_CNFG - Phase Lock Alarm Time-Out Configuration	MULTI_FACTOR[1:0]		TIME_OUT_VALUE[5:0]							P 49
09	INPUT_MODE_CNFG - Input Mode Configuration	AUTO_EX T_SYNC_ EN	EXT_SYN C_EN	PH_ALAR M_TIMEO UT	SYNC_FREQ[1:0]		IN_SONET _SDH	-	REVERTIV E_MODE	P 50	
0A	DIFFERENTIAL_IN_OUT_OSCI_CNFG - Differential Input / Output Port & Master Clock Configuration	-	-	-	-	-	OSC_EDG E	OUT1_PE CL_LVDS	-	P 51	
0B	MON_SW_PBO_CNFG - Frequency Monitor, Input Clock Selection & PBO Control	FREQ_MO N_CLK	LOS_FL G_TO_TD O	ULTR_FAS T_SW	EXT_SW	PBO_FRE Z	PBO_EN	-	FREQ_MO N_HARD_ EN	P 52	
7E	PROTECTION_CNFG - Register Protection Mode Configuration	PROTECTION_DATA[7:0]									P 53
Interrupt Registers											
0C	INTERRUPT_CNFG - Interrupt Configuration	-	-	-	-	-	-	HZ_EN	INT_POL	P 54	

Table 30: Register List and Map (Continued)

Address (Hex)	Register Name	Bit 7	Bit 6	Bit 5	Bit 4	Bit 3	Bit 2	Bit 1	Bit 0	Reference Page
0D	INTERRUPTS1_STS - Interrupt Status 1	-	-	IN2_DIFF	IN1_DIFF	IN2_CMOS	IN1_CMOS	-	-	P 54
0E	INTERRUPTS2_STS - Interrupt Status 2	T0_OPERATING_MODE	T0_MAIN_REF_FAILED	-	-	-	-	-	IN3_CMOS	P 55
0F	INTERRUPTS3_STS - Interrupt Status 3	EX_SYNC_ALARM	-	-	-	-	-	-	-	P 55
10	INTERRUPTS1_ENABLE_CNFG - Interrupt Control 1	-	-	IN2_DIFF	IN1_DIFF	IN2_CMOS	IN1_CMOS	-	-	P 56
11	INTERRUPTS2_ENABLE_CNFG - Interrupt Control 2	T0_OPERATING_MODE	T0_MAIN_REF_FAILED	-	-	-	-	-	IN3_CMOS	P 56
12	INTERRUPTS3_ENABLE_CNFG - Interrupt Control 3	EX_SYNC_ALARM	-	-	-	-	-	-	-	P 57
Input Clock Frequency & Priority Configuration Registers										
16	IN1_CMOS_CNFG - CMOS Input Clock 1 Configuration	DIRECT_DIV	LOCK_8K	BUCKET_SEL[1:0]		IN_FREQ[3:0]				P 58
17	IN2_CMOS_CNFG - CMOS Input Clock 2 Configuration	DIRECT_DIV	LOCK_8K	BUCKET_SEL[1:0]		IN_FREQ[3:0]				P 59
18	IN1_IN2_DIFF_HF_DIV_CNFG - Differential Input Clock 1 & 2 High Frequency Divider Configuration	IN2_DIFF_DIV[1:0]		-	-	-	-	IN1_DIFF_DIV[1:0]		P 60
19	IN1_DIFF_CNFG - Differential Input Clock 1 Configuration	DIRECT_DIV	LOCK_8K	BUCKET_SEL[1:0]		IN_FREQ[3:0]				P 61
1A	IN2_DIFF_CNFG - Differential Input Clock 2 Configuration	DIRECT_DIV	LOCK_8K	BUCKET_SEL[1:0]		IN_FREQ[3:0]				P 62
1D	IN3_CMOS_CNFG - CMOS Input Clock 3 Configuration	DIRECT_DIV	LOCK_8K	BUCKET_SEL[1:0]		IN_FREQ[3:0]				P 63
23	PRE_DIV_CH_CNFG - DivN Divider Channel Selection	-	-	-	-	PRE_DIV_CH_VALUE[3:0]				P 64
24	PRE_DIVN[7:0]_CNFG - DivN Divider Division Factor Configuration 1	PRE_DIVN_VALUE[7:0]								P 64
25	PRE_DIVN[14:8]_CNFG - DivN Divider Division Factor Configuration 2	-	PRE_DIVN_VALUE[14:8]							P 65
27	IN1_IN2_CMOS_SEL_PRIORITY_CNFG - CMOS Input Clock 1 & 2 Priority Configuration *	IN2_CMOS_SEL_PRIORITY[3:0]			IN1_CMOS_SEL_PRIORITY[3:0]				P 66	
28	IN1_IN2_DIFF_SEL_PRIORITY_CNFG - Differential Input Clock 1 & 2 Priority Configuration *	IN2_DIFF_SEL_PRIORITY[3:0]			IN1_DIFF_SEL_PRIORITY[3:0]				P 67	
2A	IN3_CMOS_SEL_PRIORITY_CNFG - CMOS Input Clock 3 Priority Configuration *	-	-	-	-	IN3_CMOS_SEL_PRIORITY[3:0]			P 68	
Input Clock Quality Monitoring Configuration & Status Registers										
2E	FREQ_MON_FACTOR_CNFG - Factor of Frequency Monitor Configuration	-	-	-	-	FREQ_MON_FACTOR[3:0]			P 69	
2F	ALL_FREQ_MON_THRESHOLD_CNFG - Frequency Monitor Threshold for All Input Clocks Configuration	-	-	-	-	ALL_FREQ_HARD_THRESHOLD[3:0]			P 69	

Table 30: Register List and Map (Continued)

Address (Hex)	Register Name	Bit 7	Bit 6	Bit 5	Bit 4	Bit 3	Bit 2	Bit 1	Bit 0	Reference Page	
31	UPPER_THRESHOLD_0_CNFG - Upper Threshold for Leaky Bucket Configuration 0	UPPER_THRESHOLD_0_DATA[7:0]									P 70
32	LOWER_THRESHOLD_0_CNFG - Lower Threshold for Leaky Bucket Configuration 0	LOWER_THRESHOLD_0_DATA[7:0]									P 70
33	BUCKET_SIZE_0_CNFG - Bucket Size for Leaky Bucket Configuration 0	BUCKET_SIZE_0_DATA[7:0]									P 70
34	DECAY_RATE_0_CNFG - Decay Rate for Leaky Bucket Configuration 0	-	-	-	-	-	-	DECAY_RATE_0_DATA [1:0]		P 71	
35	UPPER_THRESHOLD_1_CNFG - Upper Threshold for Leaky Bucket Configuration 1	UPPER_THRESHOLD_1_DATA[7:0]									P 71
36	LOWER_THRESHOLD_1_CNFG - Lower Threshold for Leaky Bucket Configuration 1	LOWER_THRESHOLD_1_DATA[7:0]									P 71
37	BUCKET_SIZE_1_CNFG - Bucket Size for Leaky Bucket Configuration 1	BUCKET_SIZE_1_DATA[7:0]									P 72
38	DECAY_RATE_1_CNFG - Decay Rate for Leaky Bucket Configuration 1	-	-	-	-	-	-	DECAY_RATE_1_DATA [1:0]		P 72	
39	UPPER_THRESHOLD_2_CNFG - Upper Threshold for Leaky Bucket Configuration 2	UPPER_THRESHOLD_2_DATA[7:0]									P 72
3A	LOWER_THRESHOLD_2_CNFG - Lower Threshold for Leaky Bucket Configuration 2	LOWER_THRESHOLD_2_DATA[7:0]									P 73
3B	BUCKET_SIZE_2_CNFG - Bucket Size for Leaky Bucket Configuration 2	BUCKET_SIZE_2_DATA[7:0]									P 73
3C	DECAY_RATE_2_CNFG - Decay Rate for Leaky Bucket Configuration 2	-	-	-	-	-	-	DECAY_RATE_2_DATA [1:0]		P 73	
3D	UPPER_THRESHOLD_3_CNFG - Upper Threshold for Leaky Bucket Configuration 3	UPPER_THRESHOLD_3_DATA[7:0]									P 74
3E	LOWER_THRESHOLD_3_CNFG - Lower Threshold for Leaky Bucket Configuration 3	LOWER_THRESHOLD_3_DATA[7:0]									P 74
3F	BUCKET_SIZE_3_CNFG - Bucket Size for Leaky Bucket Configuration 3	BUCKET_SIZE_3_DATA[7:0]									P 74
40	DECAY_RATE_3_CNFG - Decay Rate for Leaky Bucket Configuration 3	-	-	-	-	-	-	DECAY_RATE_3_DATA [1:0]		P 75	
41	IN_FREQ_READ_CH_CNFG - Input Clock Frequency Read Channel Selection	-	-	-	-	IN_FREQ_READ_CH[3:0]				P 75	
42	IN_FREQ_READ_STS - Input Clock Frequency Read Value	IN_FREQ_VALUE[7:0]									P 76
44	IN1_IN2_CMOS_STS - CMOS Input Clock 1 & 2 Status	-	IN2_CMOS_FREQ_H ARD_ALARM	IN2_CMOS_NO_ACTI VITY_ALARM	IN2_CMOS_PH_LOC K_ALARM	-	IN1_CMOS_FREQ_H ARD_ALARM	IN1_CMOS_NO_ACTI VITY_ALARM	IN1_CMOS_PH_LOC K_ALARM	P 77	

Table 30: Register List and Map (Continued)

Address (Hex)	Register Name	Bit 7	Bit 6	Bit 5	Bit 4	Bit 3	Bit 2	Bit 1	Bit 0	Reference Page	
45	IN1_IN2_DIFF_STS - Differential Input Clock 1 & 2 Status	-	IN2_DIFF_FREQ_HAR_ALARM	IN2_DIFF_NO_ACTIVITY_ALARM	IN2_DIFF_PH_LOCK_ALARM	-	IN1_DIFF_FREQ_HAR_ALARM	IN1_DIFF_NO_ACTIVITY_ALARM	IN1_DIFF_PH_LOCK_ALARM	P 78	
47	IN3_CMOS_STS - CMOS Input Clock 3 Status	-	-	-	-	-	IN3_CMOS_FREQ_HAR_ALARM	IN3_CMOS_NO_ACTIVITY_ALARM	IN3_CMOS_PH_LOCK_ALARM	P 79	
T0 DPLL Input Clock Selection Registers											
4A	INPUT_VALID1_STS - Input Clocks Validity 1	-	-	IN2_DIFF	IN1_DIFF	IN2_CMOS	IN1_CMOS	-	-	P 80	
4B	INPUT_VALID2_STS - Input Clocks Validity 2	-	-	-	-	-	-	-	IN3_CMOS	P 80	
4E	PRIORITY_TABLE1_STS - Priority Status 1 *	HIGHEST_PRIORITY_VALIDATED[3:0]			CURRENTLY_SELECTED_INPUT[3:0]						P 81
4F	PRIORITY_TABLE2_STS - Priority Status 2 *	THIRD_HIGHEST_PRIORITY_VALIDATED[3:0]			SECOND_HIGHEST_PRIORITY_VALIDATED[3:0]						P 82
50	T0_INPUT_SEL_CNFG - T0 Selected Input Clock Configuration	-	-	-	-	T0_INPUT_SEL[3:0]				P 82	
T0 DPLL State Machine Control Registers											
52	OPERATING_STS - DPLL Operating Status	EX_SYNC_ALARM_MON	-	T0_DPLL_SOFT_FREQ_ALARM	-	T0_DPLL_LOCK	T0_DPLL_OPERATING_MODE[2:0]			P 83	
53	T0_OPERATING_MODE_CNFG - T0 DPLL Operating Mode Configuration	-	-	-	-	-	T0_OPERATING_MODE[2:0]			P 84	
T0 DPLL & APLL Configuration Registers											
55	T0_DPLL_APLL_PATH_CNFG - T0 DPLL & APLL Path Configuration	T0_APLL_PATH[3:0]			T0_ETH_OBSAI_16E1_16T1_SEL[1:0]		T0_12E1_24T1_E3_T3_SEL[1:0]			P 85	
56	T0_DPLL_START_BW_DAMPING_CNFG - T0 DPLL Start Bandwidth & Damping Factor Configuration	T0_DPLL_START_DAMPING[2:0]			T0_DPLL_START_BW[4:0]						P 86
57	T0_DPLL_ACQ_BW_DAMPING_CNFG - T0 DPLL Acquisition Bandwidth & Damping Factor Configuration	T0_DPLL_ACQ_DAMPING[2:0]			T0_DPLL_ACQ_BW[4:0]						P 87
58	T0_DPLL_LOCKED_BW_DAMPING_CNFG - T0 DPLL Locked Bandwidth & Damping Factor Configuration	T0_DPLL_LOCKED_DAMPING[2:0]			T0_DPLL_LOCKED_BW[4:0]						P 88
59	T0_BW_OVERSHOOT_CNFG - T0 DPLL Bandwidth Overshoot Configuration	AUTO_BW_SEL	-	-	-	T0_LIMIT	-	-	-	P 88	
5A	PHASE_LOSS_COARSE_LIMIT_CNFG - Phase Loss Coarse Detector Limit Configuration *	COARSE_PH_LOSS_LIMT_EN	WIDE_EN	MULTI_PH_APP	MULTI_PH_8K_4K_2K_EN	PH_LOSS_COARSE_LIMIT[3:0]				P 89	
5B	PHASE_LOSS_FINE_LIMIT_CNFG - Phase Loss Fine Detector Limit Configuration *	FINE_PH_LOSS_LIMT_EN	FAST_LOSS_SW	-	-	-	PH_LOSS_FINE_LIMIT[2:0]			P 90	
5C	T0_HOLDOVER_MODE_CNFG - T0 DPLL Holdover Mode Configuration	MAN_HOLDOVER	AUTO_AVG	FAST_AVG	READ_AVG	TEMP_HOLDOVER_MODE[1:0]		-	-	P 91	
5D	T0_HOLDOVER_FREQ[7:0]_CNFG - T0 DPLL Holdover Frequency Configuration 1	T0_HOLDOVER_FREQ[7:0]									P 91

Table 30: Register List and Map (Continued)

Address (Hex)	Register Name	Bit 7	Bit 6	Bit 5	Bit 4	Bit 3	Bit 2	Bit 1	Bit 0	Reference Page	
5E	T0_HOLDOVER_FREQ[15:8]_CNFG - T0 DPLL Holdover Frequency Configuration 2	T0_HOLDOVER_FREQ[15:8]								P 92	
5F	T0_HOLDOVER_FREQ[23:16]_CNFG - T0 DPLL Holdover Frequency Configuration 3	T0_HOLDOVER_FREQ[23:16]								P 92	
60	DPLL_APLL_PATH_CNFG - DPLL & APLL Path Configuration	T4_APLL_PATH[3:0]			-		-			P 92	
62	CURRENT_DPLL_FREQ[7:0]_STS - DPLL Current Frequency Status 1 *	CURRENT_DPLL_FREQ[7:0]								P 93	
63	CURRENT_DPLL_FREQ[15:8]_STS - DPLL Current Frequency Status 2 *	CURRENT_DPLL_FREQ[15:8]								P 93	
64	CURRENT_DPLL_FREQ[23:16]_STS - DPLL Current Frequency Status 3 *	CURRENT_DPLL_FREQ[23:16]								P 93	
65	DPLL_FREQ_SOFT_LIMIT_CNFG - DPLL Soft Limit Configuration	FREQ_LIM_T_PH_LOS	DPLL_FREQ_SOFT_LIMIT[6:0]								P 94
66	DPLL_FREQ_HARD_LIMIT[7:0]_CNFG - DPLL Hard Limit Configuration 1	DPLL_FREQ_HARD_LIMIT[7:0]								P 94	
67	DPLL_FREQ_HARD_LIMIT[15:8]_CNFG - DPLL Hard Limit Configuration 2	DPLL_FREQ_HARD_LIMIT[15:8]								P 94	
68	CURRENT_DPLL_PHASE[7:0]_STS - DPLL Current Phase Status 1 *	CURRENT_PH_DATA[7:0]								P 95	
69	CURRENT_DPLL_PHASE[15:8]_STS - DPLL Current Phase Status 2 *	CURRENT_PH_DATA[15:8]								P 95	
6A	T0_T4_APLL_BW_CNFG - T0 / T4 APLL Bandwidth Configuration	-	-	T0_APLL_BW[1:0]	-	-	-	T4_APLL_BW[1:0]	-	P 95	
Output Configuration Registers											
6D	OUT2_FREQ_CNFG - Output Clock 2 Frequency Configuration	OUT2_PATH_SEL[3:0]			OUT2_DIVIDER[3:0]				-		P 96
71	OUT1_FREQ_CNFG - Output Clock 1 Frequency Configuration	OUT1_PATH_SEL[3:0]			OUT1_DIVIDER[3:0]				-		P 96
72	OUT1_INV_CNFG - Output Clock 1 Invert Configuration	-	-	-	-	-	-	OUT1_INV	-	P 97	
73	OUT2_INV_CNFG - Output Clock 2 Invert Configuration	-	-	-	-	-	OUT2_INV	-	-	P 97	
74	FR_MFR_SYNC_CNFG - Frame Sync & Multiframe Sync Output Configuration	IN_2K_4K_8K_INV	8K_EN	2K_EN	2K_8K_PUL_POSITON	8K_INV	8K_PUL	2K_INV	2K_PUL	P 98	
PBO & Phase Offset Control Registers											
78	PHASE_MON_PBO_CNFG - Phase Transient Monitor & PBO Configuration	IN_NOISE_WINDOW	-	PH_MON_EN	PH_MON_PBO_EN	PH_TR_MON_LIMIT[3:0]			-		P 99
7A	PHASE_OFFSET[7:0]_CNFG - Phase Offset Configuration 1	PH_OFFSET[7:0]								P 99	
7B	PHASE_OFFSET[9:8]_CNFG - Phase Offset Configuration 2	PH_OFFSET_EN	-	-	-	-	-	PH_OFFSET[9:8]		P 100	
Synchronization Configuration Registers											
7C	SYNC_MONITOR_CNFG - Sync Monitor Configuration	SYNC_BY_PASS	SYNC_MON_LIMIT[2:0]			-	-	-	-	-	P 101

Table 30: Register List and Map (Continued)

Address (Hex)	Register Name	Bit 7	Bit 6	Bit 5	Bit 4	Bit 3	Bit 2	Bit 1	Bit 0	Reference Page
7D	SYNC_PHASE_CNFG - Sync Phase Configuration	-	-	SYNC_PH3[1:0]		SYNC_PH2[1:0]		SYNC_PH1[1:0]		P 102

6.2 REGISTER DESCRIPTION

6.2.1 GLOBAL CONTROL REGISTERS

ID[7:0] - Device ID 1

Address: 00H Type: Read Default Value: 10001000							
7	6	5	4	3	2	1	0
ID7	ID6	ID5	ID4	ID3	ID2	ID1	ID0
Bit	Name	Description					
7 - 0	ID[7:0]	Refer to the description of the ID[15:8] bits (b7~0, 01H).					

ID[15:8] - Device ID 2

Address: 01H Type: Read Default Value: 00010001							
7	6	5	4	3	2	1	0
ID15	ID14	ID13	ID12	ID11	ID10	ID9	ID8
Bit	Name	Description					
7 - 0	ID[15:8]	The value in the ID[15:0] bits are pre-set, representing the identification number for the IDT82V3352.					

NOMINAL_FREQ[7:0]_CNFG - Crystal Oscillator Frequency Offset Calibration Configuration 1

Address: 04H Type: Read / Write Default Value: 00000000							
7	6	5	4	3	2	1	0
NOMINAL_FREQ_VALUE7	NOMINAL_FREQ_VALUE6	NOMINAL_FREQ_VALUE5	NOMINAL_FREQ_VALUE4	NOMINAL_FREQ_VALUE3	NOMINAL_FREQ_VALUE2	NOMINAL_FREQ_VALUE1	NOMINAL_FREQ_VALUE0
Bit	Name	Description					
7 - 0	NOMINAL_FREQ_VALUE[7:0]	Refer to the description of the NOMINAL_FREQ_VALUE[23:16] bits (b7~0, 06H).					

NOMINAL_FREQ[15:8]_CNFG - Crystal Oscillator Frequency Offset Calibration Configuration 2

Address: 05H							
Type: Read / Write							
Default Value: 00000000							
7	6	5	4	3	2	1	0
NOMINAL_FREQ_VALUE15	NOMINAL_FREQ_VALUE14	NOMINAL_FREQ_VALUE13	NOMINAL_FREQ_VALUE12	NOMINAL_FREQ_VALUE11	NOMINAL_FREQ_VALUE10	NOMINAL_FREQ_VALUE9	NOMINAL_FREQ_VALUE8
Bit	Name	Description					
7 - 0	NOMINAL_FREQ_VALUE[15:8]	Refer to the description of the NOMINAL_FREQ_VALUE[23:16] bits (b7-0, 06H).					

NOMINAL_FREQ[23:16]_CNFG - Crystal Oscillator Frequency Offset Calibration Configuration 3

Address: 06H							
Type: Read / Write							
Default Value: 00000000							
7	6	5	4	3	2	1	0
NOMINAL_FREQ_VALUE23	NOMINAL_FREQ_VALUE22	NOMINAL_FREQ_VALUE21	NOMINAL_FREQ_VALUE20	NOMINAL_FREQ_VALUE19	NOMINAL_FREQ_VALUE18	NOMINAL_FREQ_VALUE17	NOMINAL_FREQ_VALUE16
Bit	Name	Description					
7 - 0	NOMINAL_FREQ_VALUE[23:16]	<p>The NOMINAL_FREQ_VALUE[23:0] bits represent a 2's complement signed integer. If the value is multiplied by 0.0000884, the calibration value for the master clock in ppm will be gotten.</p> <p>For example, the frequency offset on OSC1 is +3 ppm. Though -3 ppm should be compensated, the calibration value is calculated as +3 ppm:</p> <p>$3 \div 0.0000884 = 33937$ (Dec.) = 8490 (Hex);</p> <p>So '008490' should be written into these bits.</p> <p>The calibration range is within ± 741 ppm.</p>					

PHASE_ALARM_TIME_OUT_CNFG - Phase Lock Alarm Time-Out Configuration

Address: 08H
 Type: Read / Write
 Default Value: 00110010

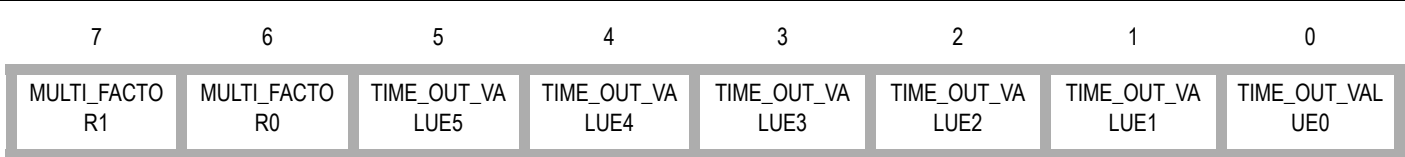

Bit	Name	Description
7 - 6	MULTI_FACTOR[1:0]	These bits determine a factor which has a relationship with a period in seconds. A phase lock alarm will be raised if the T0 selected input clock is not locked in T0 DPLL within this period. If the PH_ALARM_TIMEOUT bit (b5, 09H) is '1', the phase lock alarm will be cleared after this period (starting from when the alarm is raised). Refer to the description of the TIME_OUT_VALUE[5:0] bits (b5~0, 08H). 00: 2 (default) 01: 4 10: 8 11: 16
5 - 0	TIME_OUT_VALUE[5:0]	These bits represent an unsigned integer. If the value in these bits is multiplied by the value in the MULTI_FACTOR[1:0] bits (b7~6, 08H), a period in seconds will be gotten. A phase lock alarm will be raised if the T0 selected input clock is not locked in T0 DPLL within this period. If the PH_ALARM_TIMEOUT bit (b5, 09H) is '1', the phase lock alarm will be cleared after this period (starting from when the alarm is raised).

INPUT_MODE_CNFG - Input Mode Configuration

Address: 09H
 Type: Read / Write
 Default Value: 10100X10

7	6	5	4	3	2	1	0
AUTO_EXT_SYNC_EN	EXT_SYNC_EN	PH_ALARM_TIMEOUT	SYNC_FREQ1	SYNC_FREQ0	IN_SONET_SDH	-	REVERTIVE_MODE

Bit	Name	Description												
7	AUTO_EXT_SYNC_EN	This bit is valid only when the SYNC_BYPASS bit (b7, 7CH) is '0'. Refer to the description of the EXT_SYNC_EN bit (b6, 09H).												
6	EXT_SYNC_EN	<p>This bit is valid only when the SYNC_BYPASS bit (b7, 7CH) is '0'. This bit, together with the AUTO_EXT_SYNC_EN bit (b7, 09H), determines whether the selected frame sync input signal is enabled to synchronize the frame sync output signals.</p> <table border="1"> <thead> <tr> <th>AUTO_EXT_SYNC_EN</th> <th>EXT_SYNC_EN</th> <th>Synchronization</th> </tr> </thead> <tbody> <tr> <td style="text-align: center;">don't-care</td> <td style="text-align: center;">0</td> <td style="text-align: center;">Disabled (default)</td> </tr> <tr> <td style="text-align: center;">0</td> <td style="text-align: center;">1</td> <td style="text-align: center;">Enabled</td> </tr> <tr> <td style="text-align: center;">1</td> <td style="text-align: center;">1</td> <td style="text-align: center;">Disabled</td> </tr> </tbody> </table>	AUTO_EXT_SYNC_EN	EXT_SYNC_EN	Synchronization	don't-care	0	Disabled (default)	0	1	Enabled	1	1	Disabled
AUTO_EXT_SYNC_EN	EXT_SYNC_EN	Synchronization												
don't-care	0	Disabled (default)												
0	1	Enabled												
1	1	Disabled												
5	PH_ALARM_TIMEOUT	<p>This bit determines how to clear the phase lock alarm.</p> <p>0: The phase lock alarm will be cleared when a '1' is written to the corresponding INn_CMOS_PH_LOCK_ALARM (n = 1, 2 or 3) / INn_DIFF_PH_LOCK_ALARM (n = 1 or 2) bit (b4/0, 44H/45H/47H).</p> <p>1: The phase lock alarm will be cleared after a period (= <i>TIME_OUT_VALUE</i>[5:0] (b5~0, 08H) X <i>MULTI_FACTOR</i>[1:0] (b7~6, 08H) in second) which starts from when the alarm is raised. (default)</p>												
4 - 3	SYNC_FREQ[1:0]	<p>These bits set the frequency of the frame sync signals input on the EX_SYNC1 ~ EX_SYNC3 pins.</p> <p>00: 8 kHz (default) 01: 8 kHz. 10: 4 kHz. 11: 2 kHz.</p>												
2	IN_SONET_SDH	<p>This bit selects the SDH or SONET network type.</p> <p>0: SDH. The DPLL required clock is 2.048 MHz when the IN_FREQ[3:0] bits (b3~0, 16H, 17H, 19H, 1AH & 1DH) are '0001' and the T0 DPLL output from the 16E1/16T1 path is 16E1.</p> <p>1: SONET. The DPLL required clock is 1.544 MHz when the IN_FREQ[3:0] bits (b3~0, 16H, 17H, 19H, 1AH & 1DH) are '0001' and the T0 DPLL output from the 16E1/16T1 path is 16T1.</p> <p>The default value of this bit is determined by the SONET/SDH pin during reset.</p>												
1	-	Reserved.												
0	REVERTIVE_MODE	<p>This bit selects Revertive or Non-Revertive switch for T0 path.</p> <p>0: Non-Revertive switch. (default) 1: Revertive switch.</p>												

DIFFERENTIAL_IN_OUT_OSCI_CNFG - Differential Input / Output Port & Master Clock Configuration

Address: 0AH							
Type: Read / Write							
Default Value: XXXXX00X							
7	6	5	4	3	2	1	0
-	-	-	-	-	OSC_EDGE	OUT1_PECL_LVDS	-
Bit	Name	Description					
7-3	-	Reserved.					
2	OSC_EDGE	This bit selects a better active edge of the master clock. 0: The rising edge. (default) 1: The falling edge.					
1	OUT1_PECL_LVDS	This bit selects a port technology for OUT1. 0: LVDS. (default) 1: PECL.					
0	-	Reserved					

MON_SW_PBO_CNFG - Frequency Monitor, Input Clock Selection & PBO Control

Address: 0BH							
Type: Read / Write							
Default Value: 100X01X1							
7	6	5	4	3	2	1	0
FREQ_MON_CLK	LOS_FLAG_TO_TDO	ULTR_FAST_SW	EXT_SW	PBO_FREZ	PBO_EN	-	FREQ_MON_HARD_EN
Bit	Name	Description					
7	FREQ_MON_CLK	The bit selects a reference clock for input clock frequency monitoring. 0: The output of T0 DPLL. 1: The master clock. (default)					
6	LOS_FLAG_TO_TDO	The bit determines whether the interrupt of T0 selected input clock fail - is reported by the TDO pin. 0: Not reported. TDO pin is used as JTAG test data output which complies with IEEE 1149.1. (default) 1: Reported. TDO pin mimics the state of the T0_MAIN_REF_FAILED bit (b6, 0EH) and does not strictly comply with IEEE 1149.1.					
5	ULTR_FAST_SW	This bit determines whether the T0 selected input clock is valid when missing 2 consecutive clock cycles or more. 0: Valid. (default) 1: Invalid.					
4	EXT_SW	This bit determines the T0 input clock selection. 0: Forced selection or Automatic selection, as controlled by the T0_INPUT_SEL[3:0] bits (b3~0, 50H). 1: External Fast selection. The default value of this bit is determined by the FF_SRCSW pin during reset.					
3	PBO_FREZ	This bit is valid only when the PBO is enabled by the PBO_EN bit (b2, 0BH). It determines whether PBO is frozen at the current phase offset when a PBO event is triggered. 0: Not frozen. (default) 1: Frozen. Further PBO events are ignored and the current phase offset is maintained.					
2	PBO_EN	This bit determines whether PBO is enabled when the T0 selected input clock switch or the T0 DPLL exiting from Holdover mode or Free-Run mode occurs. 0: Disabled. 1: Enabled. (default)					
1	-	Reserved.					
0	FREQ_MON_HARD_EN	This bit determines whether the frequency hard alarm is enabled when the frequency of the input clock with respect to the reference clock is above the frequency hard alarm threshold. The reference clock can be the output of T0 DPLL or the master clock, as determined by the FREQ_MON_CLK bit (b7, 0BH). 0: Disabled. 1: Enabled. (default)					

PROTECTION_CNFG - Register Protection Mode Configuration

Address: 7EH							
Type: Read / Write							
Default Value: 10000101							
7	6	5	4	3	2	1	0
PROTECTION_ DATA7	PROTECTION_ DATA6	PROTECTION_ DATA5	PROTECTION_ DATA4	PROTECTION_ DATA3	PROTECTION_ DATA2	PROTECTION_ DATA1	PROTECTION_ DATA0
Bit	Name	Description					
7 - 0	PROTECTION_DATA[7:0]	<p>These bits select a register write protection mode.</p> <p>00000000 - 10000100, 10000111 - 11111111: Protected mode. No other registers can be written except this register.</p> <p>10000101: Fully Unprotected mode. All the writable registers can be written. (default)</p> <p>10000110: Single Unprotected mode. One more register can be written besides this register. After write operation (not including writing a '1' to clear the bit to '0'), the device automatically switches to Protected mode.</p>					

6.2.2 INTERRUPT REGISTERS

INTERRUPT_CNFG - Interrupt Configuration

Address: 0CH							
Type: Read / Write							
Default Value: XXXXXX10							
7	6	5	4	3	2	1	0
-	-	-	-	-	-	HZ_EN	INT_POL
Bit	Name	Description					
7 - 2	-	Reserved.					
1	HZ_EN	This bit determines the output characteristics of the INT_REQ pin. 0: The output on the INT_REQ pin is high/low when the interrupt is active; the output is the opposite when the interrupt is inactive. 1: The output on the INT_REQ pin is high/low when the interrupt is active; the output is in high impedance state when the interrupt is inactive. (default)					
0	INT_POL	This bit determines the active level on the INT_REQ pin for an active interrupt indication. 0: Active low. (default) 1: Active high.					

INTERRUPTS1_STS - Interrupt Status 1

Address: 0DH							
Type: Read / Write							
Default Value: XX1111XX							
7	6	5	4	3	2	1	0
-	-	IN2_DIFF	IN1_DIFF	IN2_CMOS	IN1_CMOS	-	-
Bit	Name	Description					
7 - 6	-	Reserved.					
5 - 4	INn_DIFF	This bit indicates the validity changes (from 'valid' to 'invalid' or from 'invalid' to 'valid') for the corresponding INn_DIFF; i.e., whether there is a transition (from '0' to '1' or from '1' to '0') on the corresponding INn_DIFF bit (b5/4, 4AH). Here n is 2 or 1. 0: Has not changed. 1: Has changed. (default) This bit is cleared by writing a '1'.					
3 - 2	INn_CMOS	This bit indicates the validity changes (from 'valid' to 'invalid' or from 'invalid' to 'valid') for the corresponding INn_CMOS; i.e., whether there is a transition (from '0' to '1' or from '1' to '0') on the corresponding INn_CMOS bit (b3/2, 4AH). Here n is 2 or 1. 0: Has not changed. 1: Has changed. (default) This bit is cleared by writing a '1'.					
1 - 0	-	Reserved.					

INTERRUPTS2_STS - Interrupt Status 2

Address: 0EH							
Type: Read / Write							
Default Value: 00XXXXX1							
7	6	5	4	3	2	1	0
T0_OPERATING_MODE	T0_MAIN_REF_FAILED	-	-	-	-	-	IN3_CMOS
Bit	Name	Description					
7	T0_OPERATING_MODE	This bit indicates the operating mode switch for T0 DPLL; i.e., whether the value in the T0_DPLL_OPERATING_MODE[2:0] bits (b2~0, 52H) changes. 0: Has not switched. (default) 1: Has switched. This bit is cleared by writing a '1'.					
6	T0_MAIN_REF_FAILED	This bit indicates whether the T0 selected input clock has failed. The T0 selected input clock fails when its validity changes from 'valid' to 'invalid'; i.e., when there is a transition from '1' to '0' on the corresponding INn_CMOS / INn_DIFF bit (4AH, 4BH). 0: Has not failed. (default) 1: Has failed. This bit is cleared by writing a '1'.					
5-1	-	Reserved.					
0	IN3_CMOS	This bit indicates the validity changes (from 'valid' to 'invalid' or from 'invalid' to 'valid') for IN3_CMOS for T0 path, i.e., whether there is a transition (from '0' to '1' or from '1' to '0') on the corresponding IN3_CMOS bit (b0, 4BH). 0: Has not changed. 1: Has changed. (default) This bit is cleared by writing a '1'.					

INTERRUPTS3_STS - Interrupt Status 3

Address: 0FH							
Type: Read / Write							
Default Value: 11X1XXXX							
7	6	5	4	3	2	1	0
EX_SYNC_ALARM	-	-	-	-	-	-	-
Bit	Name	Description					
7	EX_SYNC_ALARM	This bit indicates whether an external sync alarm is raised; i.e., whether there is a transition from '0' to '1' on the EX_SYNC_ALARM_MON bit (b7, 52H). 0: Has not occurred. 1: Has occurred. (default) This bit is cleared by writing a '1'.					
6-0	-	Reserved.					

INTERRUPTS1_ENABLE_CNFG - Interrupt Control 1

Address: 10H							
Type: Read / Write							
Default Value: XX0000XX							
7	6	5	4	3	2	1	0
-	-	IN2_DIFF	IN1_DIFF	IN2_CMOS	IN1_CMOS	-	-
Bit	Name	Description					
7 - 6	-	Reserved.					
5 - 4	INn_DIFF	This bit controls whether the interrupt is enabled to be reported on the INT_REQ pin when the input clock validity changes (from 'valid' to 'invalid' or from 'invalid' to 'valid'), i.e., when the corresponding INn_DIFF bit (b5/4, 0DH) is '1'. Here n is 2 or 1. 0: Disabled. (default) 1: Enabled.					
3 - 2	INn_CMOS	This bit controls whether the interrupt is enabled to be reported on the INT_REQ pin when the input clock validity changes (from 'valid' to 'invalid' or from 'invalid' to 'valid'), i.e., when the corresponding INn_CMOS bit (b3/2, 0DH) is '1'. Here n is 2 or 1. 0: Disabled. (default) 1: Enabled.					
1 - 0	-	Reserved.					

INTERRUPTS2_ENABLE_CNFG - Interrupt Control 2

Address: 11H							
Type: Read / Write							
Default Value: 00XXXXX0							
7	6	5	4	3	2	1	0
T0_OPERATING_MODE	T0_MAIN_REF_FAILED	-	-	-	-	-	IN3_CMOS
Bit	Name	Description					
7	T0_OPERATING_MODE	This bit controls whether the interrupt is enabled to be reported on the INT_REQ pin when the T0 DPLL operating mode switches, i.e., when the T0_OPERATING_MODE bit (b7, 0EH) is '1'. 0: Disabled. (default) 1: Enabled.					
6	T0_MAIN_REF_FAILED	This bit controls whether the interrupt is enabled to be reported on the INT_REQ pin when the T0 selected input clock has failed; i.e., when the T0_MAIN_REF_FAILED bit (b6, 0EH) is '1'. 0: Disabled. (default) 1: Enabled.					
5 - 1	-	Reserved.					
0	IN3_CMOS	This bit controls whether the interrupt is enabled to be reported on the INT_REQ pin when the input clock validity changes (from 'valid' to 'invalid' or from 'invalid' to 'valid'), i.e., when the corresponding IN3_CMOS bit (b0, 0EH) is '1'. 0: Disabled. (default) 1: Enabled.					

INTERRUPTS3_ENABLE_CNFG - Interrupt Control 3

Address: 12H
 Type: Read / Write
 Default Value: 00X0XXXX

7	6	5	4	3	2	1	0
EX_SYNC_ALARM	-	-	-	-	-	-	-

Bit	Name	Description
7	EX_SYNC_ALARM	This bit controls whether the interrupt is enabled to be reported on the INT_REQ pin when an external sync alarm has occurred, i.e., when the EX_SYNC_ALARM bit (b7, 0FH) is '1'. 0: Disabled. (default) 1: Enabled.
6 - 0	-	Reserved.

6.2.3 INPUT CLOCK FREQUENCY & PRIORITY CONFIGURATION REGISTERS

IN1_CMOS_CNFG - CMOS Input Clock 1 Configuration

Address: 16H							
Type: Read / Write							
Default Value: 00000000							
7	6	5	4	3	2	1	0
DIRECT_DIV	LOCK_8K	BUCKET_SEL1	BUCKET_SEL0	IN_FREQ3	IN_FREQ2	IN_FREQ1	IN_FREQ0
Bit	Name	Description					
7	DIRECT_DIV	Refer to the description of the LOCK_8K bit (b6, 16H).					
6	LOCK_8K	This bit, together with the DIRECT_DIV bit (b7, 16H), determines whether the DivN Divider or the Lock 8k Divider is used for IN1_CMOS:					
		DIRECT_DIV bit	LOCK_8K bit	Used Divider			
		0	0	Both bypassed (default)			
		0	1	Lock 8k Divider			
		1	0	DivN Divider			
1	1	Reserved					
5 - 4	BUCKET_SEL[1:0]	These bits select one of the four groups of leaky bucket configuration registers for IN1_CMOS: 00: Group 0; the addresses of the configuration registers are 31H ~ 34H. (default) 01: Group 1; the addresses of the configuration registers are 35H ~ 38H. 10: Group 2; the addresses of the configuration registers are 39H ~ 3CH. 11: Group 3; the addresses of the configuration registers are 3DH ~ 40H.					
3 - 0	IN_FREQ[3:0]	These bits set the DPLL required frequency for IN1_CMOS: 0000: 8 kHz. (default) 0001: 1.544 MHz (when the IN_SONET_SDH bit (b2, 09H) is '1') / 2.048 MHz (when the IN_SONET_SDH bit (b2, 09H) is '0'). 0010: 6.48 MHz. 0011: 19.44 MHz. 0100: 25.92 MHz. 0101: 38.88 MHz. 0110 ~ 1000: Reserved. 1001: 2 kHz. 1010: 4 kHz. 1011 ~ 1111: Reserved. For IN1_CMOS, the required frequency should not be set higher than that of the input clock.					

IN2_CMOS_CNFG - CMOS Input Clock 2 Configuration

Address: 17H																						
Type: Read / Write																						
Default Value: 00000000																						
7	6	5	4	3	2	1	0															
DIRECT_DIV	LOCK_8K	BUCKET_SEL1	BUCKET_SEL0	IN_FREQ3	IN_FREQ2	IN_FREQ1	IN_FREQ0															
Bit	Name	Description																				
7	DIRECT_DIV	Refer to the description of the LOCK_8K bit (b6, 17H).																				
6	LOCK_8K	<p>This bit, together with the DIRECT_DIV bit (b7, 17H), determines whether the DivN Divider or the Lock 8k Divider is used for IN2_CMOS:</p> <table border="1" style="margin-left: 20px;"> <thead> <tr> <th>DIRECT_DIV bit</th> <th>LOCK_8K bit</th> <th>Used Divider</th> </tr> </thead> <tbody> <tr> <td style="text-align: center;">0</td> <td style="text-align: center;">0</td> <td style="text-align: center;">Both bypassed (default)</td> </tr> <tr> <td style="text-align: center;">0</td> <td style="text-align: center;">1</td> <td style="text-align: center;">Lock 8k Divider</td> </tr> <tr> <td style="text-align: center;">1</td> <td style="text-align: center;">0</td> <td style="text-align: center;">DivN Divider</td> </tr> <tr> <td style="text-align: center;">1</td> <td style="text-align: center;">1</td> <td style="text-align: center;">Reserved</td> </tr> </tbody> </table>						DIRECT_DIV bit	LOCK_8K bit	Used Divider	0	0	Both bypassed (default)	0	1	Lock 8k Divider	1	0	DivN Divider	1	1	Reserved
DIRECT_DIV bit	LOCK_8K bit	Used Divider																				
0	0	Both bypassed (default)																				
0	1	Lock 8k Divider																				
1	0	DivN Divider																				
1	1	Reserved																				
5 - 4	BUCKET_SEL[1:0]	<p>These bits select one of the four groups of leaky bucket configuration registers for IN2_CMOS:</p> <p>00: Group 0; the addresses of the configuration registers are 31H ~ 34H. (default)</p> <p>01: Group 1; the addresses of the configuration registers are 35H ~ 38H.</p> <p>10: Group 2; the addresses of the configuration registers are 39H ~ 3CH.</p> <p>11: Group 3; the addresses of the configuration registers are 3DH ~ 40H.</p>																				
3 - 0	IN_FREQ[3:0]	<p>These bits set the DPLL required frequency for IN2_CMOS:</p> <p>0000: 8 kHz. (default)</p> <p>0001: 1.544 MHz (when the IN_SONET_SDH bit (b2, 09H) is '1') / 2.048 MHz (when the IN_SONET_SDH bit (b2, 09H) is '0').</p> <p>0010: 6.48 MHz.</p> <p>0011: 19.44 MHz.</p> <p>0100: 25.92 MHz.</p> <p>0101: 38.88 MHz.</p> <p>0110 ~ 1000: Reserved.</p> <p>1001: 2 kHz.</p> <p>1010: 4 kHz.</p> <p>1011 ~ 1111: Reserved.</p> <p>For the IN2_CMOS, the required frequency should not be set higher than that of the input clock.</p>																				

IN1_IN2_DIFF_HF_DIV_CNFG - Differential Input Clock 1 & 2 High Frequency Divider Configuration

Address: 18H
 Type: Read / Write
 Default Value: 00XXXX00



Bit	Name	Description
7 - 6	IN2_DIFF_DIV[1:0]	These bits determine whether the HF Divider is used and what the division factor is for IN2_DIFF frequency division: 00: Bypassed. (default) 01: Divided by 4. 10: Divided by 5. 11: Reserved.
5 - 2	-	Reserved.
1 - 0	IN1_DIFF_DIV[1:0]	These bits determine whether the HF Divider is used and what the division factor is for IN1_DIFF frequency division: 00: Bypassed. (default) 01: Divided by 4. 10: Divided by 5. 11: Reserved.

IN1_DIFF_CNFG - Differential Input Clock 1 Configuration

Address: 19H
 Type: Read / Write
 Default Value: 00000011



Bit	Name	Description															
7	DIRECT_DIV	Refer to the description of the LOCK_8K bit (b6, 19H).															
6	LOCK_8K	This bit, together with the DIRECT_DIV bit (b7, 19H), determines whether the DivN Divider or the Lock 8k Divider is used for IN1_DIFF: <table border="1" style="margin-left: 20px;"> <thead> <tr> <th>DIRECT_DIV bit</th> <th>LOCK_8K bit</th> <th>Used Divider</th> </tr> </thead> <tbody> <tr> <td>0</td> <td>0</td> <td>Both bypassed (default)</td> </tr> <tr> <td>0</td> <td>1</td> <td>Lock 8k Divider</td> </tr> <tr> <td>1</td> <td>0</td> <td>DivN Divider</td> </tr> <tr> <td>1</td> <td>1</td> <td>Reserved</td> </tr> </tbody> </table>	DIRECT_DIV bit	LOCK_8K bit	Used Divider	0	0	Both bypassed (default)	0	1	Lock 8k Divider	1	0	DivN Divider	1	1	Reserved
DIRECT_DIV bit	LOCK_8K bit	Used Divider															
0	0	Both bypassed (default)															
0	1	Lock 8k Divider															
1	0	DivN Divider															
1	1	Reserved															
5 - 4	BUCKET_SEL[1:0]	These bits select one of the four groups of leaky bucket configuration registers for IN1_DIFF: 00: Group 0; the addresses of the configuration registers are 31H ~ 34H. (default) 01: Group 1; the addresses of the configuration registers are 35H ~ 38H. 10: Group 2; the addresses of the configuration registers are 39H ~ 3CH. 11: Group 3; the addresses of the configuration registers are 3DH ~ 40H.															
3 - 0	IN_FREQ[3:0]	These bits set the DPLL required frequency for IN1_DIFF: 0000: 8 kHz. 0001: 1.544 MHz (when the IN_SONET_SDH bit (b2, 09H) is '1') / 2.048 MHz (when the IN_SONET_SDH bit (b2, 09H) is '0'). 0010: 6.48 MHz. 0011: 19.44 MHz. (default) 0100: 25.92 MHz. 0101: 38.88 MHz. 0110 ~ 1000: Reserved. 1001: 2 kHz. 1010: 4 kHz. 1011 ~ 1111: Reserved. The required frequency should not be set higher than that of the input clock.															

IN2_DIFF_CNFG - Differential Input Clock 2 Configuration

Address: 1AH																						
Type: Read / Write																						
Default Value: 00000011																						
7	6	5	4	3	2	1	0															
DIRECT_DIV	LOCK_8K	BUCKET_SEL1	BUCKET_SEL0	IN_FREQ3	IN_FREQ2	IN_FREQ1	IN_FREQ0															
Bit	Name	Description																				
7	DIRECT_DIV	Refer to the description of the LOCK_8K bit (b6, 1AH).																				
6	LOCK_8K	<p>This bit, together with the DIRECT_DIV bit (b7, 1AH), determines whether the DivN Divider or the Lock 8k Divider is used for IN2_DIFF:</p> <table border="1" style="margin-left: 20px;"> <thead> <tr> <th>DIRECT_DIV bit</th> <th>LOCK_8K bit</th> <th>Used Divider</th> </tr> </thead> <tbody> <tr> <td style="text-align: center;">0</td> <td style="text-align: center;">0</td> <td style="text-align: center;">Both bypassed (default)</td> </tr> <tr> <td style="text-align: center;">0</td> <td style="text-align: center;">1</td> <td style="text-align: center;">Lock 8k Divider</td> </tr> <tr> <td style="text-align: center;">1</td> <td style="text-align: center;">0</td> <td style="text-align: center;">DivN Divider</td> </tr> <tr> <td style="text-align: center;">1</td> <td style="text-align: center;">1</td> <td style="text-align: center;">Reserved</td> </tr> </tbody> </table>						DIRECT_DIV bit	LOCK_8K bit	Used Divider	0	0	Both bypassed (default)	0	1	Lock 8k Divider	1	0	DivN Divider	1	1	Reserved
DIRECT_DIV bit	LOCK_8K bit	Used Divider																				
0	0	Both bypassed (default)																				
0	1	Lock 8k Divider																				
1	0	DivN Divider																				
1	1	Reserved																				
5 - 4	BUCKET_SEL[1:0]	<p>These bits select one of the four groups of leaky bucket configuration registers for IN2_DIFF:</p> <p>00: Group 0; the addresses of the configuration registers are 31H ~ 34H. (default)</p> <p>01: Group 1; the addresses of the configuration registers are 35H ~ 38H.</p> <p>10: Group 2; the addresses of the configuration registers are 39H ~ 3CH.</p> <p>11: Group 3; the addresses of the configuration registers are 3DH ~ 40H.</p>																				
3 - 0	IN_FREQ[3:0]	<p>These bits set the DPLL required frequency for IN2_DIFF:</p> <p>0000: 8 kHz.</p> <p>0001: 1.544 MHz (when the IN_SONET_SDH bit (b2, 09H) is '1') / 2.048 MHz (when the IN_SONET_SDH bit (b2, 09H) is '0').</p> <p>0010: 6.48 MHz.</p> <p>0011: 19.44 MHz. (default)</p> <p>0100: 25.92 MHz.</p> <p>0101: 38.88 MHz.</p> <p>0110 ~ 1000: Reserved.</p> <p>1001: 2 kHz.</p> <p>1010: 4 kHz.</p> <p>1011 ~ 1111: Reserved.</p> <p>For IN2_DIFF, the required frequency should not be set higher than that of the input clock.</p>																				

IN3_CMOS_CNFG - CMOS Input Clock 3 Configuration

Address: 1DH
 Type: Read / Write
 Default Value: 00000011

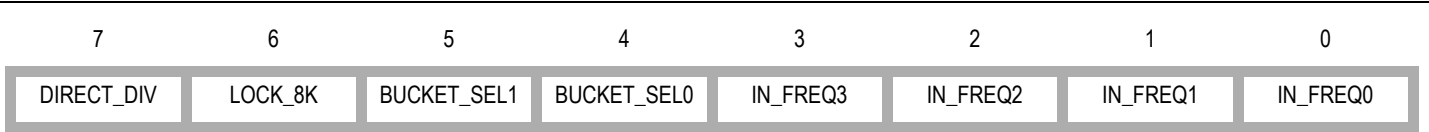

Bit	Name	Description															
7	DIRECT_DIV	Refer to the description of the LOCK_8K bit (b6, 1DH).															
6	LOCK_8K	This bit, together with the DIRECT_DIV bit (b7, 1DH), determines whether the DivN Divider or the Lock 8k Divider is used for IN3_CMOS: <table border="1" style="margin: 10px auto; border-collapse: collapse;"> <thead> <tr> <th>DIRECT_DIV bit</th> <th>LOCK_8K bit</th> <th>Used Divider</th> </tr> </thead> <tbody> <tr> <td style="text-align: center;">0</td> <td style="text-align: center;">0</td> <td style="text-align: center;">Both bypassed (default)</td> </tr> <tr> <td style="text-align: center;">0</td> <td style="text-align: center;">1</td> <td style="text-align: center;">Lock 8k Divider</td> </tr> <tr> <td style="text-align: center;">1</td> <td style="text-align: center;">0</td> <td style="text-align: center;">DivN Divider</td> </tr> <tr> <td style="text-align: center;">1</td> <td style="text-align: center;">1</td> <td style="text-align: center;">Reserved</td> </tr> </tbody> </table>	DIRECT_DIV bit	LOCK_8K bit	Used Divider	0	0	Both bypassed (default)	0	1	Lock 8k Divider	1	0	DivN Divider	1	1	Reserved
DIRECT_DIV bit	LOCK_8K bit	Used Divider															
0	0	Both bypassed (default)															
0	1	Lock 8k Divider															
1	0	DivN Divider															
1	1	Reserved															
5 - 4	BUCKET_SEL[1:0]	These bits select one of the four groups of leaky bucket configuration registers for IN3_CMOS: 00: Group 0; the addresses of the configuration registers are 31H ~ 34H. (default) 01: Group 1; the addresses of the configuration registers are 35H ~ 38H. 10: Group 2; the addresses of the configuration registers are 39H ~ 3CH. 11: Group 3; the addresses of the configuration registers are 3DH ~ 40H.															
3 - 0	IN_FREQ[3:0]	These bits set the DPLL required frequency for IN3_CMOS: 0000: 8 kHz. 0001: 1.544 MHz (when the IN_SONET_SDH bit (b2, 09H) is '1') / 2.048 MHz (when the IN_SONET_SDH bit (b2, 09H) is '0'). 0010: 6.48 MHz. 0011: 19.44 MHz. (default) 0100: 25.92 MHz. 0101: 38.88 MHz. 0110 ~ 1000: Reserved. 1001: 2 kHz. 1010: 4 kHz. 1011 ~ 1111: Reserved. For IN3_CMOS, the required frequency should not be set higher than that of the input clock.															

PRE_DIV_CH_CNFG - DivN Divider Channel Selection

Address: 23H							
Type: Read / Write							
Default Value: XXXX0000							
7	6	5	4	3	2	1	0
-	-	-	-	PRE_DIV_CH_VALUE3	PRE_DIV_CH_VALUE2	PRE_DIV_CH_VALUE1	PRE_DIV_CH_VALUE0
Bit	Name	Description					
7 - 4	-	Reserved.					
3 - 0	PRE_DIV_CH_VALUE[3:0]	This register is an indirect address register for Register 24H and 25H. These bits select an input clock. The value set in the PRE_DIVN_VALUE[14:0] bits (25H, 24H) is available for the selected input clock. 0000: Reserved. (default) 0001, 0010: Reserved. 0011: IN1_CMOS. 0100: IN2_CMOS. 0101: IN1_DIFF. 0110: IN2_DIFF. 0111, 1000: Reserved. 1001: IN3_CMOS. 1010 ~ 1111: Reserved.					

PRE_DIVN[7:0]_CNFG - DivN Divider Division Factor Configuration 1

Address: 24H							
Type: Read / Write							
Default Value: 00000000							
7	6	5	4	3	2	1	0
PRE_DIVN_VA LUE7	PRE_DIVN_VA LUE6	PRE_DIVN_VA LUE5	PRE_DIVN_VA LUE4	PRE_DIVN_VA LUE3	PRE_DIVN_VA LUE2	PRE_DIVN_VA LUE1	PRE_DIVN_VA LUE0
Bit	Name	Description					
7 - 0	PRE_DIVN_VALUE[7:0]	Refer to the description of the PRE_DIVN_VALUE[14:8] bits (b6~0, 25H).					

PRE_DIVN[14:8]_CNFG - DivN Divider Division Factor Configuration 2

Address: 25H							
Type: Read / Write							
Default Value: X0000000							
7	6	5	4	3	2	1	0
-	PRE_DIVN_VAL UE14	PRE_DIVN_VAL UE13	PRE_DIVN_VAL UE12	PRE_DIVN_VAL UE11	PRE_DIVN_VAL UE10	PRE_DIVN_VAL UE9	PRE_DIVN_VAL UE8
Bit	Name	Description					
7	-	Reserved.					
6 - 0	PRE_DIVN_VALUE[14:8]	<p>If the value in the PRE_DIVN_VALUE[14:0] bits is plus 1, the division factor for an input clock will be gotten. The input clock is selected by the PRE_DIV_CH_VALUE[3:0] bits (b3~0, 23H). A value from '0' to '4BEF' (Hex) can be written into, corresponding to a division factor from 1 to 19440. The others are reserved. So the DivN Divider only supports an input clock whose frequency is lower than (<) 155.52 MHz.</p> <p>The division factor setting should observe the following order:</p> <ol style="list-style-type: none"> 1. Write the lower eight bits of the division factor to the PRE_DIVN_VALUE[7:0] bits; 2. Write the higher eight bits of the division factor to the PRE_DIVN_VALUE[14:8] bits. 					

IN1_IN2_CMOS_SEL_PRIORITY_CNFG - CMOS Input Clock 1 & 2 Priority Configuration *

Address: 27H							
Type: Read / Write							
Default Value: 00110010							
7	6	5	4	3	2	1	0
IN2_CMOS_SE L_PRIORITY3	IN2_CMOS_SE L_PRIORITY2	IN2_CMOS_SE L_PRIORITY1	IN2_CMOS_SE L_PRIORITY0	IN1_CMOS_SE L_PRIORITY3	IN1_CMOS_SE L_PRIORITY2	IN1_CMOS_SE L_PRIORITY1	IN1_CMOS_SE L_PRIORITY0
Bit	Name	Description					
7 - 4	INn_CMOS_SEL_PRIORITY[3:0]	These bits set the priority of the corresponding INn_CMOS. Here n is 2. 0000: Disable INn_CMOS for automatic selection. 0001: Priority 1. 0010: Priority 2. 0011: Priority 3. (default) 0100: Priority 4. 0101: Priority 5. 0110: Priority 6. 0111: Priority 7. 1000: Priority 8. 1001: Priority 9. 1010: Priority 10. 1011: Priority 11. 1100: Priority 12. 1101: Priority 13. 1110: Priority 14. 1111: Priority 15.					
3 - 0	INn_CMOS_SEL_PRIORITY[3:0]	These bits set the priority of the corresponding INn_CMOS. Here n is 1. 0000: Disable INn_CMOS for automatic selection. 0001: Priority 1. 0010: Priority 2. (default) 0011: Priority 3. 0100: Priority 4. 0101: Priority 5. 0110: Priority 6. 0111: Priority 7. 1000: Priority 8. 1001: Priority 9. 1010: Priority 10. 1011: Priority 11. 1100: Priority 12. 1101: Priority 13. 1110: Priority 14. 1111: Priority 15.					

IN1_IN2_DIFF_SEL_PRIORITY_CNFG - Differential Input Clock 1 & 2 Priority Configuration *

Address: 28H							
Type: Read / Write							
Default Value: 00000000							
7	6	5	4	3	2	1	0
IN2_DIFF_SEL_PRIORITY3	IN2_DIFF_SEL_PRIORITY2	IN2_DIFF_SEL_PRIORITY1	IN2_DIFF_SEL_PRIORITY0	IN1_DIFF_SEL_PRIORITY3	IN1_DIFF_SEL_PRIORITY2	IN1_DIFF_SEL_PRIORITY1	IN1_DIFF_SEL_PRIORITY0
Bit	Name	Description					
7 - 4	INn_DIFF_SEL_PRIORITY[3:0]	These bits set the priority of the corresponding INn_DIFF. Here n is 2. 0000: Disable INn_DIFF for automatic selection. (default) 0001: Priority 1. 0010: Priority 2. 0011: Priority 3. 0100: Priority 4. 0101: Priority 5. 0110: Priority 6. 0111: Priority 7. 1000: Priority 8. 1001: Priority 9. 1010: Priority 10. 1011: Priority 11. 1100: Priority 12. 1101: Priority 13. 1110: Priority 14. 1111: Priority 15.					
3 - 0	INn_DIFF_SEL_PRIORITY[3:0]	These bits set the priority of the corresponding INn_DIFF. Here n is 1. 0000: Disable INn_DIFF for automatic selection. (default) 0001: Priority 1. 0010: Priority 2. 0011: Priority 3. 0100: Priority 4. 0101: Priority 5. 0110: Priority 6. 0111: Priority 7. 1000: Priority 8. 1001: Priority 9. 1010: Priority 10. 1011: Priority 11. 1100: Priority 12. 1101: Priority 13. 1110: Priority 14. 1111: Priority 15.					

IN3_CMOS_SEL_PRIORITY_CNFG - CMOS Input Clock 3 Priority Configuration *

Address: 2AH							
Type: Read / Write							
Default Value: XXXX0100							
7	6	5	4	3	2	1	0
-	-	-	-	IN3_CMOS_SE L_PRIORITY3	IN3_CMOS_SE L_PRIORITY2	IN3_CMOS_SE L_PRIORITY1	IN3_CMOS_SE L_PRIORITY0
Bit	Name	Description					
7 - 4	-	Reserved.					
3 - 0	IN3_CMOS_SEL_PRIORITY[3:0]	These bits set the priority of the corresponding IN3_CMOS. 0000: Disable INn for automatic selection. 0001: Priority 1. 0010: Priority 2. 0011: Priority 3. 0100: Priority 4. (default) 0101: Priority 5. 0110: Priority 6. 0111: Priority 7. 1000: Priority 8. 1001: Priority 9. 1010: Priority 10. 1011: Priority 11. 1100: Priority 12. 1101: Priority 13. 1110: Priority 14. 1111: Priority 15.					

6.2.4 INPUT CLOCK QUALITY MONITORING CONFIGURATION & STATUS REGISTERS

FREQ_MON_FACTOR_CNFG - Factor of Frequency Monitor Configuration

Address: 2EH							
Type: Read / Write							
Default Value: XXXX1011							
7	6	5	4	3	2	1	0
-	-	-	-	FREQ_MON_F ACTOR3	FREQ_MON_F ACTOR2	FREQ_MON_F ACTOR1	FREQ_MON_F ACTOR0
Bit	Name	Description					
7 - 4	-	Reserved.					
3 - 0	FREQ_MON_FACTOR[3:0]	<p>These bits determine a factor. The factor has a relationship with the frequency hard alarm threshold in ppm (refer to the description of the ALL_FREQ_HARD_THRESHOLD[3:0] bits (b3~0, 2FH)) and with the frequency of the input clock with respect to the master clock in ppm (refer to the description of the IN_FREQ_VALUE[7:0] bits (b7~0, 42H)). The factor represents the accuracy of the frequency monitor and should be set according to the requirements of different applications.</p> <p>0000: 0.0032. 0001: 0.0064. 0010: 0.0127. 0011: 0.0257. 0100: 0.0514. 0101: 0.103. 0110: 0.206. 0111: 0.412. 1000: 0.823. 1001: 1.646. 1010: 3.292. 1011: 3.81. (default) 1100 - 1111: 4.6.</p>					

ALL_FREQ_MON_THRESHOLD_CNFG - Frequency Monitor Threshold for All Input Clocks Configuration

Address: 2FH							
Type: Read / Write							
Default Value: XXXX0011							
7	6	5	4	3	2	1	0
-	-	-	-	ALL_FREQ_HARD_ THRESHOLD3	ALL_FREQ_HARD_ THRESHOLD2	ALL_FREQ_HARD_ THRESHOLD1	ALL_FREQ_HARD_ THRESHOLD0
Bit	Name	Description					
7 - 4	-	Reserved.					
3 - 0	ALL_FREQ_HARD_THRESHOLD[3:0]	<p>These bits represent an unsigned integer. The frequency hard alarm threshold in ppm can be calculated as follows:</p> <p>Frequency Hard Alarm Threshold (ppm) = (ALL_FREQ_HARD_THRESHOLD[3:0] + 1) X FREQ_MON_FACTOR[3:0] (b3~0, 2EH)</p> <p>This threshold is symmetrical about zero.</p>					

UPPER_THRESHOLD_0_CNFG - Upper Threshold for Leaky Bucket Configuration 0

Address: 31H Type: Read / Write Default Value: 00000110							
7	6	5	4	3	2	1	0
UPPER_THRE SHOLD_0_DAT A7	UPPER_THRE SHOLD_0_DAT A6	UPPER_THRE SHOLD_0_DAT A5	UPPER_THRE SHOLD_0_DAT A4	UPPER_THRE SHOLD_0_DAT A3	UPPER_THRE SHOLD_0_DAT A2	UPPER_THRE SHOLD_0_DAT A1	UPPER_THRE SHOLD_0_DAT A0
Bit	Name	Description					
7 - 0	UPPER_THRESHOLD_0_DATA[7:0]	These bits set an upper threshold for the internal leaky bucket accumulator. When the number of the accumulated events is above this threshold, a no-activity alarm is raised.					

LOWER_THRESHOLD_0_CNFG - Lower Threshold for Leaky Bucket Configuration 0

Address: 32H Type: Read / Write Default Value: 00000100							
7	6	5	4	3	2	1	0
LOWER_THRE SHOLD_0_DAT A7	LOWER_THRE SHOLD_0_DAT A6	LOWER_THRE SHOLD_0_DAT A5	LOWER_THRE SHOLD_0_DAT A4	LOWER_THRE SHOLD_0_DAT A3	LOWER_THRE SHOLD_0_DAT A2	LOWER_THRE SHOLD_0_DAT A1	LOWER_THRE SHOLD_0_DAT A0
Bit	Name	Description					
7 - 0	LOWER_THRESHOLD_0_DATA[7:0]	These bits set a lower threshold for the internal leaky bucket accumulator. When the number of the accumulated events is below this threshold, the no-activity alarm is cleared.					

BUCKET_SIZE_0_CNFG - Bucket Size for Leaky Bucket Configuration 0

Address: 33H Type: Read / Write Default Value: 00001000							
7	6	5	4	3	2	1	0
BUCKET_SIZE _0_DATA7	BUCKET_SIZE _0_DATA6	BUCKET_SIZE _0_DATA5	BUCKET_SIZE _0_DATA4	BUCKET_SIZE _0_DATA3	BUCKET_SIZE _0_DATA2	BUCKET_SIZE _0_DATA1	BUCKET_SIZE _0_DATA0
Bit	Name	Description					
7 - 0	BUCKET_SIZE_0_DATA[7:0]	These bits set a bucket size for the internal leaky bucket accumulator. If the number of the accumulated events reach the bucket size, the accumulator will stop increasing even if further events are detected.					

DECAY_RATE_0_CNFG - Decay Rate for Leaky Bucket Configuration 0

Address: 34H							
Type: Read / Write							
Default Value: XXXXXX01							
7	6	5	4	3	2	1	0
-	-	-	-	-	-	DECAY_RATE_0_DATA1	DECAY_RATE_0_DATA0
Bit	Name	Description					
7 - 2	-	Reserved.					
1 - 0	DECAY_RATE_0_DATA[1:0]	These bits set a decay rate for the internal leaky bucket accumulator: 00: The accumulator decreases by 1 in every 128 ms with no event detected. 01: The accumulator decreases by 1 in every 256 ms with no event detected. (default) 10: The accumulator decreases by 1 in every 512 ms with no event detected. 11: The accumulator decreases by 1 in every 1024 ms with no event detected.					

UPPER_THRESHOLD_1_CNFG - Upper Threshold for Leaky Bucket Configuration 1

Address: 35H							
Type: Read / Write							
Default Value: 00000110							
7	6	5	4	3	2	1	0
UPPER_THRE SHOLD_1_DAT A7	UPPER_THRE SHOLD_1_DAT A6	UPPER_THRE SHOLD_1_DAT A5	UPPER_THRE SHOLD_1_DAT A4	UPPER_THRE SHOLD_1_DAT A3	UPPER_THRE SHOLD_1_DAT A2	UPPER_THRE SHOLD_1_DAT A1	UPPER_THRE SHOLD_1_DAT A0
Bit	Name	Description					
7 - 0	UPPER_THRESHOLD_1_DATA[7:0]	These bits set an upper threshold for the internal leaky bucket accumulator. When the number of the accumulated events is above this threshold, a no-activity alarm is raised.					

LOWER_THRESHOLD_1_CNFG - Lower Threshold for Leaky Bucket Configuration 1

Address: 36H							
Type: Read / Write							
Default Value: 00000100							
7	6	5	4	3	2	1	0
LOWER_THRE SHOLD_1_DAT A7	LOWER_THRE SHOLD_1_DAT A6	LOWER_THRE SHOLD_1_DAT A5	LOWER_THRE SHOLD_1_DAT A4	LOWER_THRE SHOLD_1_DAT A3	LOWER_THRE SHOLD_1_DAT A2	LOWER_THRE SHOLD_1_DAT A1	LOWER_THRE SHOLD_1_DAT A0
Bit	Name	Description					
7 - 0	LOWER_THRESHOLD_1_DATA[7:0]	These bits set a lower threshold for the internal leaky bucket accumulator. When the number of the accumulated events is below this threshold, the no-activity alarm is cleared.					

BUCKET_SIZE_1_CNFG - Bucket Size for Leaky Bucket Configuration 1

Address: 37H Type: Read / Write Default Value: 00001000							
7	6	5	4	3	2	1	0
BUCKET_SIZE_1_DATA7	BUCKET_SIZE_1_DATA6	BUCKET_SIZE_1_DATA5	BUCKET_SIZE_1_DATA4	BUCKET_SIZE_1_DATA3	BUCKET_SIZE_1_DATA2	BUCKET_SIZE_1_DATA1	BUCKET_SIZE_1_DATA0
Bit	Name	Description					
7 - 0	BUCKET_SIZE_1_DATA[7:0]	These bits set a bucket size for the internal leaky bucket accumulator. If the number of the accumulated events reach the bucket size, the accumulator will stop increasing even if further events are detected.					

DECAY_RATE_1_CNFG - Decay Rate for Leaky Bucket Configuration 1

Address: 38H Type: Read / Write Default Value: XXXXXX01							
7	6	5	4	3	2	1	0
-	-	-	-	-	-	DECAY_RATE_1_DATA1	DECAY_RATE_1_DATA0
Bit	Name	Description					
7 - 2	-	Reserved.					
1 - 0	DECAY_RATE_1_DATA[1:0]	These bits set a decay rate for the internal leaky bucket accumulator: 00: The accumulator decreases by 1 in every 128 ms with no event detected. 01: The accumulator decreases by 1 in every 256 ms with no event detected. (default) 10: The accumulator decreases by 1 in every 512 ms with no event detected. 11: The accumulator decreases by 1 in every 1024 ms with no event detected.					

UPPER_THRESHOLD_2_CNFG - Upper Threshold for Leaky Bucket Configuration 2

Address: 39H Type: Read / Write Default Value: 00000110							
7	6	5	4	3	2	1	0
UPPER_THRE_SHOLD_2_DATA7	UPPER_THRE_SHOLD_2_DATA6	UPPER_THRE_SHOLD_2_DATA5	UPPER_THRE_SHOLD_2_DATA4	UPPER_THRE_SHOLD_2_DATA3	UPPER_THRE_SHOLD_2_DATA2	UPPER_THRE_SHOLD_2_DATA1	UPPER_THRE_SHOLD_2_DATA0
Bit	Name	Description					
7 - 0	UPPER_THRESHOLD_2_DATA[7:0]	These bits set an upper threshold for the internal leaky bucket accumulator. When the number of the accumulated events is above this threshold, a no-activity alarm is raised.					

LOWER_THRESHOLD_2_CNFG - Lower Threshold for Leaky Bucket Configuration 2

Address: 3AH							
Type: Read / Write							
Default Value: 00000100							
7	6	5	4	3	2	1	0
LOWER_THRE SHOLD_2_DAT A7	LOWER_THRE SHOLD_2_DAT A6	LOWER_THRE SHOLD_2_DAT A5	LOWER_THRE SHOLD_2_DAT A4	LOWER_THRE SHOLD_2_DAT A3	LOWER_THRE SHOLD_2_DAT A2	LOWER_THRE SHOLD_2_DAT A1	LOWER_THRE SHOLD_2_DAT A0
Bit	Name	Description					
7 - 0	LOWER_THRESHOLD_2_DATA[7:0]	These bits set a lower threshold for the internal leaky bucket accumulator. When the number of the accumulated events is below this threshold, the no-activity alarm is cleared.					

BUCKET_SIZE_2_CNFG - Bucket Size for Leaky Bucket Configuration 2

Address: 3BH							
Type: Read / Write							
Default Value: 00001000							
7	6	5	4	3	2	1	0
BUCKET_SIZE _2_DATA7	BUCKET_SIZE _2_DATA6	BUCKET_SIZE _2_DATA5	BUCKET_SIZE _2_DATA4	BUCKET_SIZE _2_DATA3	BUCKET_SIZE _2_DATA2	BUCKET_SIZE _2_DATA1	BUCKET_SIZE _2_DATA0
Bit	Name	Description					
7 - 0	BUCKET_SIZE_2_DATA[7:0]	These bits set a bucket size for the internal leaky bucket accumulator. If the number of the accumulated events reach the bucket size, the accumulator will stop increasing even if further events are detected.					

DECAY_RATE_2_CNFG - Decay Rate for Leaky Bucket Configuration 2

Address: 3CH							
Type: Read / Write							
Default Value: XXXXXX01							
7	6	5	4	3	2	1	0
-	-	-	-	-	-	DECAY_RATE_ 2_DATA1	DECAY_RATE_ 2_DATA0
Bit	Name	Description					
7 - 2	-	Reserved.					
1 - 0	DECAY_RATE_2_DATA[1:0]	These bits set a decay rate for the internal leaky bucket accumulator: 00: The accumulator decreases by 1 in every 128 ms with no event detected. 01: The accumulator decreases by 1 in every 256 ms with no event detected. (default) 10: The accumulator decreases by 1 in every 512 ms with no event detected. 11: The accumulator decreases by 1 in every 1024 ms with no event detected.					

UPPER_THRESHOLD_3_CNFG - Upper Threshold for Leaky Bucket Configuration 3

Address: 3DH							
Type: Read / Write							
Default Value: 00000110							
7	6	5	4	3	2	1	0
UPPER_THRE SHOLD_3_DAT A7	UPPER_THRE SHOLD_3_DAT A6	UPPER_THRE SHOLD_3_DAT A5	UPPER_THRE SHOLD_3_DAT A4	UPPER_THRE SHOLD_3_DAT A3	UPPER_THRE SHOLD_3_DAT A2	UPPER_THRE SHOLD_3_DAT A1	UPPER_THRE SHOLD_3_DAT A0
Bit	Name	Description					
7 - 0	UPPER_THRESHOLD_3_DATA[7:0]	These bits set an upper threshold for the internal leaky bucket accumulator. When the number of the accumulated events is above this threshold, a no-activity alarm is raised.					

LOWER_THRESHOLD_3_CNFG - Lower Threshold for Leaky Bucket Configuration 3

Address: 3EH							
Type: Read / Write							
Default Value: 00000100							
7	6	5	4	3	2	1	0
LOWER_THRE SHOLD_3_DAT A7	LOWER_THRE SHOLD_3_DAT A6	LOWER_THRE SHOLD_3_DAT A5	LOWER_THRE SHOLD_3_DAT A4	LOWER_THRE SHOLD_3_DAT A3	LOWER_THRE SHOLD_3_DAT A2	LOWER_THRE SHOLD_3_DAT A1	LOWER_THRE SHOLD_3_DAT A0
Bit	Name	Description					
7 - 0	LOWER_THRESHOLD_3_DATA[7:0]	These bits set a lower threshold for the internal leaky bucket accumulator. When the number of the accumulated events is below this threshold, the no-activity alarm is cleared.					

BUCKET_SIZE_3_CNFG - Bucket Size for Leaky Bucket Configuration 3

Address: 3FH							
Type: Read / Write							
Default Value: 00001000							
7	6	5	4	3	2	1	0
BUCKET_SIZE _3_DATA7	BUCKET_SIZE _3_DATA6	BUCKET_SIZE _3_DATA5	BUCKET_SIZE _3_DATA4	BUCKET_SIZE _3_DATA3	BUCKET_SIZE _3_DATA2	BUCKET_SIZE _3_DATA1	BUCKET_SIZE _3_DATA0
Bit	Name	Description					
7 - 0	BUCKET_SIZE_3_DATA[7:0]	These bits set a bucket size for the internal leaky bucket accumulator. If the number of the accumulated events reach the bucket size, the accumulator will stop increasing even if further events are detected.					

DECAY_RATE_3_CNFG - Decay Rate for Leaky Bucket Configuration 3

Address: 40H Type: Read / Write Default Value: XXXXXX01							
7	6	5	4	3	2	1	0
-	-	-	-	-	-	DECAY_RATE_3_DATA1	DECAY_RATE_3_DATA0
Bit	Name	Description					
7 - 2	-	Reserved.					
1 - 0	DECAY_RATE_3_DATA[1:0]	These bits set a decay rate for the internal leaky bucket accumulator: 00: The accumulator decreases by 1 in every 128 ms with no event detected. 01: The accumulator decreases by 1 in every 256 ms with no event detected. (default) 10: The accumulator decreases by 1 in every 512 ms with no event detected. 11: The accumulator decreases by 1 in every 1024 ms with no event detected.					

IN_FREQ_READ_CH_CNFG - Input Clock Frequency Read Channel Selection

Address: 41H Type: Read / Write Default Value: XXXX0000							
7	6	5	4	3	2	1	0
-	-	-	-	IN_FREQ_READ_CH3	IN_FREQ_READ_CH2	IN_FREQ_READ_CH1	IN_FREQ_READ_CH0
Bit	Name	Description					
7 - 4	-	Reserved.					
3 - 0	IN_FREQ_READ_CH[3:0]	These bits select an input clock, the frequency of which with respect to the reference clock can be read. 0000: Reserved. (default) 0001, 0010: Reserved. 0011: IN1_CMOS. 0100: IN2_CMOS. 0101: IN1_DIFF. 0110: IN2_DIFF. 0111, 1000: Reserved. 1001: IN3_CMOS. 1010 ~ 1111: Reserved.					

IN_FREQ_READ_STS - Input Clock Frequency Read Value

Address: 42H
 Type: Read
 Default Value: 00000000

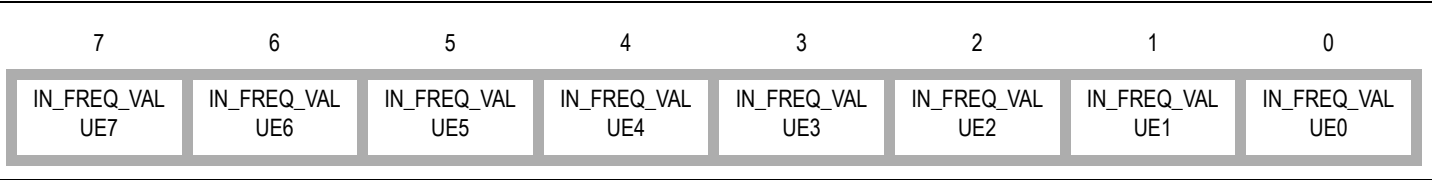

Bit	Name	Description
7 - 0	IN_FREQ_VALUE[7:0]	These bits represent a 2's complement signed integer. If the value is multiplied by the value in the FREQ_MON_FACTOR[3:0] bits (b3~0, 2EH), the frequency of an input clock with respect to the reference clock in ppm will be gotten. The input clock is selected by the IN_FREQ_READ_CH[3:0] bits (b3~0, 41H). The value in these bits is updated every 16 seconds, starting when an input clock is selected.

IN1_IN2_CMOS_STS - CMOS Input Clock 1 & 2 Status

Address: 44H
 Type: Read
 Default Value: X110X110

7	6	5	4	3	2	1	0
-	IN2_CMOS_FREQ_HARD_ALARM	IN2_CMOS_NO_ACTIVITY_ALARM	IN2_CMOS_PH_LOCK_ALARM	-	IN1_CMOS_FREQ_HARD_ALARM	IN1_CMOS_NO_ACTIVITY_ALARM	IN1_CMOS_PH_LOCK_ALARM

Bit	Name	Description
7	-	Reserved.
6	IN2_CMOS_FREQ_HARD_ALARM	This bit indicates whether IN2_CMOS is in frequency hard alarm status. 0: No frequency hard alarm. 1: In frequency hard alarm status. (default)
5	IN2_CMOS_NO_ACTIVITY_ALARM	This bit indicates whether IN2_CMOS is in no-activity alarm status. 0: No no-activity alarm. 1: In no-activity alarm status. (default)
4	IN2_CMOS_PH_LOCK_ALARM	This bit indicates whether IN2_CMOS is in phase lock alarm status. 0: No phase lock alarm. (default) 1: In phase lock alarm status. If the PH_ALARM_TIMEOUT bit (b5, 09H) is '0', this bit is cleared by writing '1' to this bit; if the PH_ALARM_TIMEOUT bit (b5, 09H) is '1', this bit is cleared after a period (= TIME_OUT_VALUE[5:0] (b5~0, 08H) X MULTI_FACTOR[1:0] (b7~6, 08H) in second) which starts from when the alarm is raised.
3	-	Reserved.
2	IN1_CMOS_FREQ_HARD_ALARM	This bit indicates whether IN1_CMOS is in frequency hard alarm status. 0: No frequency hard alarm. 1: In frequency hard alarm status. (default)
1	IN1_CMOS_NO_ACTIVITY_ALARM	This bit indicates whether IN1_CMOS is in no-activity alarm status. 0: No no-activity alarm. 1: In no-activity alarm status. (default)
0	IN1_CMOS_PH_LOCK_ALARM	This bit indicates whether IN1_CMOS is in phase lock alarm status. 0: No phase lock alarm. (default) 1: In phase lock alarm status. If the PH_ALARM_TIMEOUT bit (b5, 09H) is '0', this bit is cleared by writing '1' to this bit; if the PH_ALARM_TIMEOUT bit (b5, 09H) is '1', this bit is cleared after a period (= TIME_OUT_VALUE[5:0] (b5~0, 08H) X MULTI_FACTOR[1:0] (b7~6, 08H) in second) which starts from when the alarm is raised.

IN1_IN2_DIFF_STS - Differential Input Clock 1 & 2 Status

Address: 45H							
Type: Read							
Default Value: X110X110							
7	6	5	4	3	2	1	0
-	IN2_DIFF_FREQ_HARD_ALARM	IN2_DIFF_NO_ACTIVITY_ALARM	IN2_DIFF_PH_LOCK_ALARM	-	IN1_DIFF_FREQ_HARD_ALARM	IN1_DIFF_NO_ACTIVITY_ALARM	IN1_DIFF_PH_LOCK_ALARM
Bit	Name	Description					
7	-	Reserved.					
6	IN2_DIFF_FREQ_HARD_ALARM	This bit indicates whether IN2_DIFF is in frequency hard alarm status. 0: No frequency hard alarm. 1: In frequency hard alarm status. (default)					
5	IN2_DIFF_NO_ACTIVITY_ALARM	This bit indicates whether IN2_DIFF is in no-activity alarm status. 0: No no-activity alarm. 1: In no-activity alarm status. (default)					
4	IN2_DIFF_PH_LOCK_ALARM	This bit indicates whether IN2_DIFF is in phase lock alarm status. 0: No phase lock alarm. (default) 1: In phase lock alarm status. If the PH_ALARM_TIMEOUT bit (b5, 09H) is '0', this bit is cleared by writing '1' to this bit; if the PH_ALARM_TIMEOUT bit (b5, 09H) is '1', this bit is cleared after a period (= TIME_OUT_VALUE[5:0] (b5~0, 08H) X MULTI_FACTOR[1:0] (b7~6, 08H) in second) which starts from when the alarm is raised.					
3	-	Reserved.					
2	IN1_DIFF_FREQ_HARD_ALARM	This bit indicates whether IN1_DIFF is in frequency hard alarm status. 0: No frequency hard alarm. 1: In frequency hard alarm status. (default)					
1	IN1_DIFF_NO_ACTIVITY_ALARM	This bit indicates whether IN1_DIFF is in no-activity alarm status. 0: No no-activity alarm. 1: In no-activity alarm status. (default)					
0	IN1_DIFF_PH_LOCK_ALARM	This bit indicates whether IN1_DIFF is in phase lock alarm status. 0: No phase lock alarm. (default) 1: In phase lock alarm status. If the PH_ALARM_TIMEOUT bit (b5, 09H) is '0', this bit is cleared by writing '1' to this bit; if the PH_ALARM_TIMEOUT bit (b5, 09H) is '1', this bit is cleared after a period (= TIME_OUT_VALUE[5:0] (b5~0, 08H) X MULTI_FACTOR[1:0] (b7~6, 08H) in second) which starts from when the alarm is raised.					

IN3_CMOS_STS - CMOS Input Clock 3 Status

Address: 47H
 Type: Read
 Default Value: XXXXX110

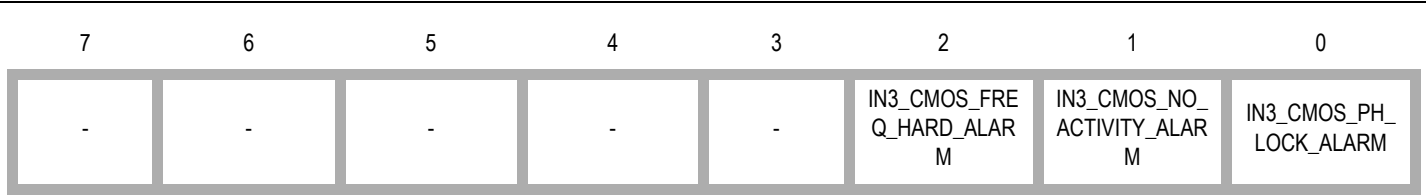

Bit	Name	Description
7 - 3	-	Reserved.
2	IN3_CMOS_FREQ_HARD_ALARM	This bit indicates whether IN3_CMOS is in frequency hard alarm status. 0: No frequency hard alarm. 1: In frequency hard alarm status. (default)
1	IN3_CMOS_NO_ACTIVITY_ALARM	This bit indicates whether IN3_CMOS is in no-activity alarm status. 0: No no-activity alarm. 1: In no-activity alarm status. (default)
0	IN3_CMOS_PHASE_LOCK_ALARM	This bit indicates whether IN3_CMOS is in phase lock alarm status. 0: No phase lock alarm. (default) 1: In phase lock alarm status. If the PH_ALARM_TIMEOUT bit (b5, 09H) is '0', this bit is cleared by writing '1' to this bit; if the PH_ALARM_TIMEOUT bit (b5, 09H) is '1', this bit is cleared after a period (= TIME_OUT_VALUE[5:0] (b5~0, 08H) X MULTI_FACTOR[1:0] (b7~6, 08H) in second) which starts from when the alarm is raised.

6.2.5 T0 DPLL INPUT CLOCK SELECTION REGISTERS

INPUT_VALID1_STS - Input Clocks Validity 1

Address: 4AH							
Type: Read							
Default Value: XX0000XX							
7	6	5	4	3	2	1	0
-	-	IN2_DIFF	IN1_DIFF	IN2_CMOS	IN1_CMOS	-	-
Bit	Name	Description					
7 - 6	-	Reserved.					
5 - 4	INn_DIFF	This bit indicates the validity of the corresponding INn_DIFF. Here n is 2 or 1. 0: Invalid. (default) 1: Valid.					
3 - 2	INn_CMOS	This bit indicates the validity of the corresponding INn_CMOS. Here n is 2 or 1. 0: Invalid. (default) 1: Valid.					
1 - 0	-	Reserved.					

INPUT_VALID2_STS - Input Clocks Validity 2

Address: 4BH							
Type: Read							
Default Value: XXXXXXX0							
7	6	5	4	3	2	1	0
-	-	-	-	-	-	-	IN3_CMOS
Bit	Name	Description					
7 - 1	-	Reserved.					
0	IN3_CMOS	This bit indicates the validity of the corresponding IN3_CMOS. 0: Invalid. (default) 1: Valid.					

PRIORITY_TABLE1_STS - Priority Status 1 *

Address: 4EH
 Type: Read
 Default Value: 00000000

7	6	5	4	3	2	1	0
HIGHEST_PRIORITY_VALIDATED3	HIGHEST_PRIORITY_VALIDATED2	HIGHEST_PRIORITY_VALIDATED1	HIGHEST_PRIORITY_VALIDATED0	CURRENTLY_SELECTED_INP UT3	CURRENTLY_SELECTED_INP UT2	CURRENTLY_SELECTED_INP UT1	CURRENTLY_SELECTED_INP UT0

Bit	Name	Description
7 - 4	HIGHEST_PRIORITY_VALIDATED[3:0]	These bits indicate a qualified input clock with the highest priority. 0000: No input clock is qualified. (default) 0001, 0010: Reserved. 0011: IN1_CMOS. 0100: IN2_CMOS. 0101: IN1_DIFF. 0110: IN2_DIFF. 0111, 1000: Reserved. 1001: IN3_CMOS. 1010 ~ 1111: Reserved.
3 - 0	CURRENTLY_SELECTED_INPUT[3:0]	These bits indicate the selected input clock. 0000: No input clock is selected. (default) 0001, 0010: Reserved. 0011: IN1_CMOS is selected. 0100: IN2_CMOS is selected. 0101: IN1_DIFF is selected. 0110: IN2_DIFF is selected. 0111, 1000: Reserved. 1001: IN3_CMOS is selected. 1010 ~ 1111: Reserved.

PRIORITY_TABLE2_STS - Priority Status 2 *

Address: 4FH
 Type: Read
 Default Value: 00000000

7	6	5	4	3	2	1	0
THIRD_HIGHEST_PRIORITY_VALIDATED3	THIRD_HIGHEST_PRIORITY_VALIDATED2	THIRD_HIGHEST_PRIORITY_VALIDATED1	THIRD_HIGHEST_PRIORITY_VALIDATED0	SECOND_HIGHEST_PRIORITY_VALIDATED3	SECOND_HIGHEST_PRIORITY_VALIDATED2	SECOND_HIGHEST_PRIORITY_VALIDATED1	SECOND_HIGHEST_PRIORITY_VALIDATED0

Bit	Name	Description
7 - 4	THIRD_HIGHEST_PRIORITY_VALIDATED[3:0]	These bits indicate a qualified input clock with the third highest priority. 0000: No input clock is qualified. (default) 0001, 0010: Reserved. 0011: IN1_CMOS. 0100: IN2_CMOS. 0101: IN1_DIFF. 0110: IN2_DIFF. 0111, 1000: Reserved. 1001: IN3_CMOS. 1010 ~ 1111: Reserved.
3 - 0	SECOND_HIGHEST_PRIORITY_VALIDATED[3:0]	These bits indicate a qualified input clock with the second highest priority. 0000: No input clock is qualified. (default) 0001, 0010: Reserved. 0011: IN1_CMOS. 0100: IN2_CMOS. 0101: IN1_DIFF. 0110: IN2_DIFF. 0111, 1000: Reserved. 1001: IN3_CMOS. 1010 ~ 1111: Reserved.

T0_INPUT_SEL_CNFG - T0 Selected Input Clock Configuration

Address: 50H
 Type: Read / Write
 Default Value: XXXX0000

7	6	5	4	3	2	1	0
-	-	-	-	T0_INPUT_SEL3	T0_INPUT_SEL2	T0_INPUT_SEL1	T0_INPUT_SEL0

Bit	Name	Description
7 - 4	-	Reserved.
3 - 0	T0_INPUT_SEL[3:0]	This bit determines T0 input clock selection. It is valid only when the EXT_SW bit (b4, 0BH) is '0'. 0000: Automatic selection. (default) 0001, 0010: Reserved. 0011: Forced selection - IN1_CMOS is selected. 0100: Forced selection - IN2_CMOS is selected. 0101: Forced selection - IN1_DIFF is selected. 0110: Forced selection - IN2_DIFF is selected. 0111, 1000: Reserved. 1001: Forced selection - IN3_CMOS is selected. 1010 ~ 1111: Reserved.

6.2.6 T0 DPLL STATE MACHINE CONTROL REGISTERS

OPERATING_STS - DPLL Operating Status

Address: 52H							
Type: Read							
Default Value: 10000001							
7	6	5	4	3	2	1	0
EX_SYNC_ALARM_MON	-	T0_DPLL_SOFT_FREQ_ALARM	-	T0_DPLL_LOCK	T0_DPLL_OPERATING_MODE2	T0_DPLL_OPERATING_MODE1	T0_DPLL_OPERATING_MODE0
Bit	Name	Description					
7	EX_SYNC_ALARM_MON	This bit indicates whether the selected frame sync input signal is in external sync alarm status. 0: No external sync alarm. 1: In external sync alarm status. (default)					
6	-	Reserved.					
5	T0_DPLL_SOFT_FREQ_ALARM	This bit indicates whether the T0 DPLL is in soft alarm status. 0: No T0 DPLL soft alarm. (default) 1: In T0 DPLL soft alarm status.					
4	-	Reserved.					
3	T0_DPLL_LOCK	This bit indicates the T0 DPLL locking status. 0: Unlocked. (default) 1: Locked.					
2 - 0	T0_DPLL_OPERATING_MODE[2:0]	These bits indicate the current operating mode of T0 DPLL. 000: Reserved. 001: Free-Run. (default) 010: Holdover. 011: Reserved. 100: Locked. 101: Pre-Locked2. 110: Pre-Locked. 111: Lost-Phase.					

T0_OPERATING_MODE_CNFG - T0 DPLL Operating Mode Configuration

Address: 53H
 Type: Read / Write
 Default Value: XXXXX000

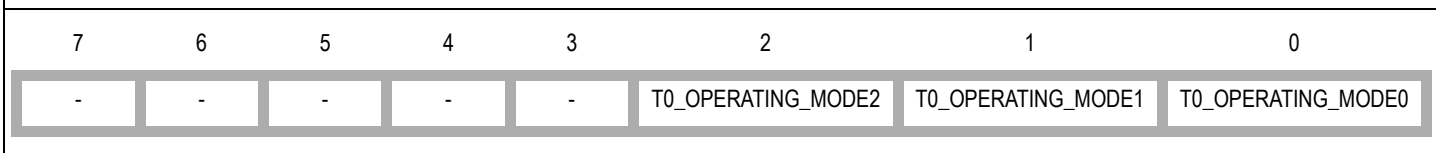

Bit	Name	Description
7 - 3	-	Reserved.
2 - 0	T0_OPERATING_MODE[2:0]	These bits control the T0 DPLL operating mode. 000: Automatic. (default) 001: Forced - Free-Run. 010: Forced - Holdover. 011: Reserved. 100: Forced - Locked. 101: Forced - Pre-Locked2. 110: Forced - Pre-Locked. 111: Forced - Lost-Phase.

6.2.7 T0 DPLL & APLL CONFIGURATION REGISTERS

T0_DPLL_APLL_PATH_CNFG - T0 DPLL & APLL Path Configuration

Address: 55H							
Type: Read / Write							
Default Value: 00000X0X							
7	6	5	4	3	2	1	0
T0_APLL_PATH 3	T0_APLL_PA TH2	T0_APLL_PA TH1	T0_APLL_PA TH0	T0_ETH_OBSAI_ 16E1_16T1_SEL1	T0_ETH_OBSAI_ 16E1_16T1_SELO	T0_12E1_24T1_ E3_T3_SEL1	T0_12E1_24T1_ E3_T3_SELO
Bit	Name	Description					
7 - 4	T0_APLL_PATH[3:0]	These bits select an input to the T0 APLL. 0000: The output of T0 DPLL 77.76 MHz path. (default) 0001: The output of T0 DPLL 12E1/24T1/E3/T3 path. 0010: The output of T0 DPLL 16E1/16T1 path. 0011: The output of T0 DPLL ETH/OBSAI/16E1/16T1 path. 0100~1XXX: Reserved.					
3 - 2	T0_ETH_OBSAI_16E1_16T1_SEL[1:0]	These bits select an output clock from the T0 DPLL ETH/OBSAI/16E1/16T1 path. 00: 16E1. 01: 16T1. 10: ETH. 11: OBSAI. The default value of the T0_ETH_OBSAI_16E1_16T1_SELO bit is determined by the SONET/SDH pin during reset.					
1 - 0	T0_12E1_24T1_E3_T3_SEL[1:0]	These bits select an output clock from the T0 DPLL 12E1/24T1/E3/T3 path. 00: 12E1. 01: 24T1. 10: E3. 11: T3. The default value of the T0_12E1_24T1_E3_T3_SELO bit is determined by the SONET/SDH pin during reset.					

T0_DPLL_START_BW_DAMPING_CNFG - T0 DPLL Start Bandwidth & Damping Factor Configuration

Address: 56H
 Type: Read / Write
 Default Value: 01101111

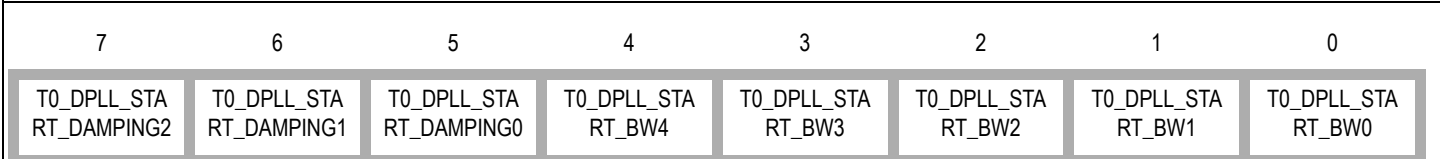

Bit	Name	Description
7 - 5	T0_DPLL_START_DAMPING[2:0]	These bits set the starting damping factor for T0 DPLL. 000: Reserved. 001: 1.2. 010: 2.5. 011: 5. (default) 100: 10. 101: 20. 110, 111: Reserved.
4 - 0	T0_DPLL_START_BW[4:0]	These bits set the starting bandwidth for T0 DPLL. 00XXX: Reserved. 01000: 0.1 Hz. 01001: 0.3 Hz. 01010: 0.6 Hz. 01011: 1.2 Hz. 01100: 2.5 Hz. 01101: 4 Hz. 01110: 8 Hz. 01111: 18 Hz. (default) 10000: 35 Hz. 10001: 70 Hz. 10010: 560 Hz. 10011 ~ 11111: Reserved.

T0_DPLL_ACQ_BW_DAMPING_CNFG - T0 DPLL Acquisition Bandwidth & Damping Factor Configuration

Address: 57H
 Type: Read / Write
 Default Value: 01101111

7	6	5	4	3	2	1	0
T0_DPLL_ACQ_DAMPING2	T0_DPLL_ACQ_DAMPING1	T0_DPLL_ACQ_DAMPING0	T0_DPLL_ACQ_BW4	T0_DPLL_ACQ_BW3	T0_DPLL_ACQ_BW2	T0_DPLL_ACQ_BW1	T0_DPLL_ACQ_BW0
Bit	Name	Description					
7 - 5	T0_DPLL_ACQ_DAMPING[2:0]	These bits set the acquisition damping factor for T0 DPLL. 000: Reserved. 001: 1.2. 010: 2.5. 011: 5. (default) 100: 10. 101: 20. 110, 111: Reserved.					
4 - 0	T0_DPLL_ACQ_BW[4:0]	These bits set the acquisition bandwidth for T0 DPLL. 00XXX: Reserved. 01000: 0.1 Hz. 01001: 0.3 Hz. 01010: 0.6 Hz. 01011: 1.2 Hz. 01100: 2.5 Hz. 01101: 4 Hz. 01110: 8 Hz. 01111: 18 Hz. (default) 10000: 35 Hz. 10001: 70 Hz. 10010: 560 Hz. 10011 ~ 11111: Reserved.					

T0_DPLL_LOCKED_BW_DAMPING_CNFG - T0 DPLL Locked Bandwidth & Damping Factor Configuration

Address: 58H							
Type: Read / Write							
Default Value: 01101111							
7	6	5	4	3	2	1	0
T0_DPLL_LOCK ED_DAMPING2	T0_DPLL_LOCK ED_DAMPING1	T0_DPLL_LOCK ED_DAMPING0	T0_DPLL_LOC KED_BW4	T0_DPLL_LOC KED_BW3	T0_DPLL_LOC KED_BW2	T0_DPLL_LOC KED_BW1	T0_DPLL_LOC KED_BW0
Bit	Name	Description					
7 - 5	T0_DPLL_LOCKED_DAMPING[2:0]	These bits set the locked damping factor for T0 DPLL. 000: Reserved. 001: 1.2. 010: 2.5. 011: 5. (default) 100: 10. 101: 20. 110, 111: Reserved.					
4 - 0	T0_DPLL_LOCKED_BW[4:0]	These bits set the locked bandwidth for T0 DPLL. 00XXX: Reserved. 01000: 0.1 Hz. 01001: 0.3 Hz. 01010: 0.6 Hz. 01011: 1.2 Hz. (default) 01100: 2.5 Hz. 01101: 4 Hz. 01110: 8 Hz. 01111: 18 Hz. 10000: 35 Hz. 10001: 70 Hz. 10010: 560 Hz. 10011 ~ 11111: Reserved.					

T0_BW_OVERSHOOT_CNFG - T0 DPLL Bandwidth Overshoot Configuration

Address: 59H							
Type: Read / Write							
Default Value: 1XXX1XXX							
7	6	5	4	3	2	1	0
AUTO_BW_SEL	-	-	-	T0_LIMT	-	-	-
Bit	Name	Description					
7	AUTO_BW_SEL	This bit determines whether starting or acquisition bandwidth / damping factor is used for T0 DPLL. 0: The starting and acquisition bandwidths / damping factors are not used. Only the locked bandwidth / damping factor is used regardless of the T0 DPLL locking stage. 1: The starting, acquisition or locked bandwidth / damping factor is used automatically depending on different T0 DPLL locking stages. (default)					
6 - 4	-	Reserved.					
3	T0_LIMT	This bit determines whether the integral path value is frozen when the T0 DPLL hard limit is reached. 0: Not frozen. 1: Frozen. It will minimize the subsequent overshoot when T0 DPLL is pulling in. (default)					
2 - 0	-	Reserved.					

PHASE_LOSS_COARSE_LIMIT_CNFG - Phase Loss Coarse Detector Limit Configuration *

Address: 5AH
 Type: Read / Write
 Default Value: 10000101

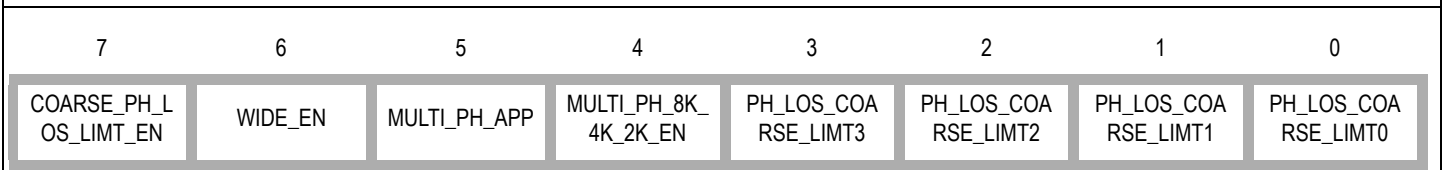

Bit	Name	Description																					
7	COARSE_PH_LOS_LIMT_EN	This bit controls whether the occurrence of the coarse phase loss will result in the T0 DPLL unlocked. 0: Disabled. 1: Enabled. (default)																					
6	WIDE_EN	Refer to the description of the MULTI_PH_8K_4K_2K_EN bit (b4, 5AH).																					
5	MULTI_PH_APP	This bit determines whether the PFD output of T0 DPLL is limited to ±1 UI or is limited to the coarse phase limit. 0: Limited to ±1 UI. (default) 1: Limited to the coarse phase limit. When the selected input clock is of 2 kHz, 4 kHz or 8 kHz, the coarse phase limit depends on the MULTI_PH_8K_4K_2K_EN bit, the WIDE_EN bit and the PH_LOS_COARSE_LIMT[3:0] bits; when the selected input clock is of other frequencies but 2 kHz, 4 kHz and 8 kHz, the coarse phase limit depends on the WIDE_EN bit and the PH_LOS_COARSE_LIMT[3:0] bits. Refer to the description of the MULTI_PH_8K_4K_2K_EN bit (b4, 5AH) for details.																					
4	MULTI_PH_8K_4K_2K_EN	This bit, together with the WIDE_EN bit (b6, 5AH) and the PH_LOS_COARSE_LIMT[3:0] bits (b3~0, 5AH), determines the coarse phase limit when the selected input clock is of 2 kHz, 4 kHz or 8 kHz. When the selected input clock is of other frequencies but 2 kHz, 4 kHz and 8 kHz, the coarse phase limit depends on the WIDE_EN bit and the PH_LOS_COARSE_LIMT[3:0] bits. <table border="1" style="margin: 10px auto; border-collapse: collapse; text-align: center;"> <thead> <tr> <th style="width: 20%;">Selected Input Clock</th> <th style="width: 15%;">MULTI_PH_8K_4K_2K_EN</th> <th style="width: 15%;">WIDE_EN</th> <th style="width: 50%;">Coarse Phase Limit</th> </tr> </thead> <tbody> <tr> <td rowspan="2">2 kHz, 4 kHz or 8 kHz</td> <td>0</td> <td>don't-care</td> <td>±1 UI</td> </tr> <tr> <td>1</td> <td>0</td> <td>±1 UI</td> </tr> <tr> <td rowspan="2">other than 2 kHz, 4 kHz and 8 kHz</td> <td rowspan="2">don't-care</td> <td>1</td> <td>set by the PH_LOS_COARSE_LIMT[3:0] bits (b3~0, 5AH).</td> </tr> <tr> <td>0</td> <td>±1 UI</td> </tr> <tr> <td></td> <td></td> <td>1</td> <td>set by the PH_LOS_COARSE_LIMT[3:0] bits (b3~0, 5AH).</td> </tr> </tbody> </table>	Selected Input Clock	MULTI_PH_8K_4K_2K_EN	WIDE_EN	Coarse Phase Limit	2 kHz, 4 kHz or 8 kHz	0	don't-care	±1 UI	1	0	±1 UI	other than 2 kHz, 4 kHz and 8 kHz	don't-care	1	set by the PH_LOS_COARSE_LIMT[3:0] bits (b3~0, 5AH).	0	±1 UI			1	set by the PH_LOS_COARSE_LIMT[3:0] bits (b3~0, 5AH).
Selected Input Clock	MULTI_PH_8K_4K_2K_EN	WIDE_EN	Coarse Phase Limit																				
2 kHz, 4 kHz or 8 kHz	0	don't-care	±1 UI																				
	1	0	±1 UI																				
other than 2 kHz, 4 kHz and 8 kHz	don't-care	1	set by the PH_LOS_COARSE_LIMT[3:0] bits (b3~0, 5AH).																				
		0	±1 UI																				
		1	set by the PH_LOS_COARSE_LIMT[3:0] bits (b3~0, 5AH).																				
3 - 0	PH_LOS_COARSE_LIMT[3:0]	These bit set the coarse phase limit. The limit is used only in some cases. Refer to the description of the MULTI_PH_8K_4K_2K_EN bit (b4, 5AH). 0000: ±1 UI. 0001: ±3 UI. 0010: ±7 UI. 0011: ±15 UI. 0100: ±31 UI. 0101: ±63 UI. (default) 0110: ±127 UI. 0111: ±255 UI. 1000: ±511 UI. 1001: ±1023 UI. 1010-1111: Reserved.																					

PHASE_LOSS_FINE_LIMIT_CNFG - Phase Loss Fine Detector Limit Configuration *

Address: 5BH							
Type: Read / Write							
Default Value: 10XXX010							
7	6	5	4	3	2	1	0
FINE_PH_LOS_LIMIT_EN	FAST_LOS_SW	-	-	-	PH_LOS_FINE_LIMIT2	PH_LOS_FINE_LIMIT1	PH_LOS_FINE_LIMIT0
Bit	Name	Description					
7	FINE_PH_LOS_LIMIT_EN	This bit controls whether the occurrence of the fine phase loss will result in the T0 DPLL unlocked. 0: Disabled. 1: Enabled. (default)					
6	FAST_LOS_SW	The value in this bit can be switched only when it is available for T0 path. This bit controls whether the occurrence of the fast loss will result in the T0 DPLL unlocked. 0: Does not result in the T0 DPLL unlocked. T0 DPLL will enter Temp-Holdover mode automatically. (default) 1: Results in the T0 DPLL unlocked. For T0 path, T0 DPLL will enter Lost-Phase mode if the T0 DPLL operating mode is switched automatically.					
5 - 3	-	Reserved.					
2 - 0	PH_LOS_FINE_LIMIT[2:0]	These bits set a fine phase limit. 000: 0. 001: ± (45 ° ~ 90 °). 010: ± (90 ° ~ 180 °). (default) 011: ± (180 ° ~ 360 °). 100: ± (20 ns ~ 25 ns). 101: ± (60 ns ~ 65 ns). 110: ± (120 ns ~ 125 ns). 111: ± (950 ns ~ 955 ns).					

T0_HOLDOVER_MODE_CNFG - T0 DPLL Holdover Mode Configuration

Address: 5CH
 Type: Read / Write
 Default Value: 010001XX

7	6	5	4	3	2	1	0
MAN_HOLDOVER	AUTO_AVG	FAST_AVG	READ_AVG	TEMP_HOLDOVER_MODE1	TEMP_HOLDOVER_MODE0	-	-

Bit	Name	Description																		
7	MAN_HOLDOVER	Refer to the description of the FAST_AVG bit (b5, 5CH).																		
6	AUTO_AVG	Refer to the description of the FAST_AVG bit (b5, 5CH).																		
5	FAST_AVG	This bit, together with the AUTO_AVG bit (b6, 5CH) and the MAN_HOLDOVER bit (b7, 5CH), determines a frequency offset acquiring method in T0 DPLL Holdover Mode. <table border="1" style="width:100%; margin-top: 5px; border-collapse: collapse;"> <thead> <tr> <th>MAN_HOLDOVER</th> <th>AUTO_AVG</th> <th>FAST_AVG</th> <th>Frequency Offset Acquiring Method</th> </tr> </thead> <tbody> <tr> <td rowspan="2">0</td> <td>0</td> <td>don't-care</td> <td>Automatic Instantaneous</td> </tr> <tr> <td>1</td> <td>0</td> <td>Automatic Slow Averaged (default)</td> </tr> <tr> <td rowspan="2">1</td> <td>1</td> <td>1</td> <td>Automatic Fast Averaged</td> </tr> <tr> <td colspan="2">don't-care</td> <td>Manual</td> </tr> </tbody> </table>	MAN_HOLDOVER	AUTO_AVG	FAST_AVG	Frequency Offset Acquiring Method	0	0	don't-care	Automatic Instantaneous	1	0	Automatic Slow Averaged (default)	1	1	1	Automatic Fast Averaged	don't-care		Manual
MAN_HOLDOVER	AUTO_AVG	FAST_AVG	Frequency Offset Acquiring Method																	
0	0	don't-care	Automatic Instantaneous																	
	1	0	Automatic Slow Averaged (default)																	
1	1	1	Automatic Fast Averaged																	
	don't-care		Manual																	
4	READ_AVG	This bit controls the holdover frequency offset reading, which is read from the T0_HOLDOVER_FREQ[23:0] bits (5FH ~ 5DH). 0: The value read from the T0_HOLDOVER_FREQ[23:0] bits (5FH ~ 5DH) is equal to the one written to them. (default) 1: The value read from the T0_HOLDOVER_FREQ[23:0] bits (5FH ~ 5DH) is not equal to the one written to them. The value is acquired by Automatic Slow Averaged method if the FAST_AVG bit (b5, 5CH) is '0'; or is acquired by Automatic Fast Averaged method if the FAST_AVG bit (b5, 5CH) is '1'.																		
3 - 2	TEMP_HOLDOVER_MODE[1:0]	These bits determine the frequency offset acquiring method in T0 DPLL Temp-Holdover Mode. 00: The method is the same as that used in T0 DPLL Holdover mode. 01: Automatic Instantaneous. (default) 10: Automatic Fast Averaged. 11: Automatic Slow Averaged.																		
1 - 0	-	Reserved.																		

T0_HOLDOVER_FREQ[7:0]_CNFG - T0 DPLL Holdover Frequency Configuration 1

Address: 5DH
 Type: Read / Write
 Default Value: 00000000

7	6	5	4	3	2	1	0
T0_HOLDOVER_FREQ7	T0_HOLDOVER_FREQ6	T0_HOLDOVER_FREQ5	T0_HOLDOVER_FREQ4	T0_HOLDOVER_FREQ3	T0_HOLDOVER_FREQ2	T0_HOLDOVER_FREQ1	T0_HOLDOVER_FREQ0

Bit	Name	Description
7 - 0	T0_HOLDOVER_FREQ[7:0]	Refer to the description of the T0_HOLDOVER_FREQ[23:16] bits (b7~0, 5FH).

T0_HOLDOVER_FREQ[15:8]_CNFG - T0 DPLL Holdover Frequency Configuration 2

Address: 5EH							
Type: Read / Write							
Default Value: 00000000							
7	6	5	4	3	2	1	0
T0_HOLDOVER_FREQ15	T0_HOLDOVER_FREQ14	T0_HOLDOVER_FREQ13	T0_HOLDOVER_FREQ12	T0_HOLDOVER_FREQ11	T0_HOLDOVER_FREQ10	T0_HOLDOVER_FREQ9	T0_HOLDOVER_FREQ8
Bit	Name	Description					
7-0	T0_HOLDOVER_FREQ[15:8]	Refer to the description of the T0_HOLDOVER_FREQ[23:16] bits (b7~0, 5FH).					

T0_HOLDOVER_FREQ[23:16]_CNFG - T0 DPLL Holdover Frequency Configuration 3

Address: 5FH							
Type: Read / Write							
Default Value: 00000000							
7	6	5	4	3	2	1	0
T0_HOLDOVER_FREQ23	T0_HOLDOVER_FREQ22	T0_HOLDOVER_FREQ21	T0_HOLDOVER_FREQ20	T0_HOLDOVER_FREQ19	T0_HOLDOVER_FREQ18	T0_HOLDOVER_FREQ17	T0_HOLDOVER_FREQ16
Bit	Name	Description					
7-0	T0_HOLDOVER_FREQ[23:16]	The T0_HOLDOVER_FREQ[23:0] bits represent a 2's complement signed integer. In T0 DPLL Holdover mode, the value written to these bits multiplied by 0.000011 is the frequency offset set manually; the value read from these bits multiplied by 0.000011 is the frequency offset automatically slow or fast averaged or manually set, as determined by the READ_AVG bit (b4, 5CH) and the FAST_AVG bit (b5, 5CH).					

DPLL_APLL_PATH_CNFG - DPLL & APLL Path Configuration

Address: 60H							
Type: Read / Write							
Default Value: 01000X0X							
7	6	5	4	3	2	1	0
T4_APLL_PATH3	T4_APLL_PATH2	T4_APLL_PATH1	T4_APLL_PATH0	-	-	-	-
Bit	Name	Description					
7-4	T4_APLL_PATH[3:0]	These bits select an input to the T4 APLL. 0000: The output of T0 DPLL 77.76 MHz path. 0001: The output of T0 DPLL 12E1/24T1/E3/T3 path. 0010: The output of T0 DPLL 16E1/16T1 path. 0011: The output of T0 DPLL ETH/OBSAI/16E1/16T1 path. 0100~1XXX: Reserved.					
3-0	-	Reserved.					

CURRENT_DPLL_FREQ[7:0]_STS - DPLL Current Frequency Status 1 *

Address: 62H Type: Read Default Value: 00000000							
7	6	5	4	3	2	1	0
CURRENT_DP LL_FREQ7	CURRENT_DP LL_FREQ6	CURRENT_DP LL_FREQ5	CURRENT_DP LL_FREQ4	CURRENT_DP LL_FREQ3	CURRENT_DP LL_FREQ2	CURRENT_DP LL_FREQ1	CURRENT_DP LL_FREQ0
Bit	Name	Description					
7 - 0	CURRENT_DPLL_FREQ[7:0]	Refer to the description of the CURRENT_DPLL_FREQ[23:16] bits (b7~0, 64H).					

CURRENT_DPLL_FREQ[15:8]_STS - DPLL Current Frequency Status 2 *

Address: 63H Type: Read Default Value: 00000000							
7	6	5	4	3	2	1	0
CURRENT_DP LL_FREQ15	CURRENT_DP LL_FREQ14	CURRENT_DP LL_FREQ13	CURRENT_DP LL_FREQ12	CURRENT_DP LL_FREQ11	CURRENT_DP LL_FREQ10	CURRENT_DP LL_FREQ9	CURRENT_DP LL_FREQ8
Bit	Name	Description					
7 - 0	CURRENT_DPLL_FREQ[15:8]	Refer to the description of the CURRENT_DPLL_FREQ[23:16] bits (b7~0, 64H).					

CURRENT_DPLL_FREQ[23:16]_STS - DPLL Current Frequency Status 3 *

Address: 64H Type: Read Default Value: 00000000							
7	6	5	4	3	2	1	0
CURRENT_DP LL_FREQ23	CURRENT_DP LL_FREQ22	CURRENT_DP LL_FREQ21	CURRENT_DP LL_FREQ20	CURRENT_DP LL_FREQ19	CURRENT_DP LL_FREQ18	CURRENT_DP LL_FREQ17	CURRENT_DP LL_FREQ16
Bit	Name	Description					
7 - 0	CURRENT_DPLL_FREQ[23:16]	The CURRENT_DPLL_FREQ[23:0] bits represent a 2's complement signed integer. If the value in these bits is multiplied by 0.000011, the current frequency offset of the T0 DPLL output in ppm with respect to the master clock will be gotten.					

DPLL_FREQ_SOFT_LIMIT_CNFG - DPLL Soft Limit Configuration

Address: 65H Type: Read / Write Default Value: 10001100							
7	6	5	4	3	2	1	0
FREQ_LIMIT_PH_LOS	DPLL_FREQ_SOFT_LIMIT6	DPLL_FREQ_SOFT_LIMIT5	DPLL_FREQ_SOFT_LIMIT4	DPLL_FREQ_SOFT_LIMIT3	DPLL_FREQ_SOFT_LIMIT2	DPLL_FREQ_SOFT_LIMIT1	DPLL_FREQ_SOFT_LIMIT0
Bit	Name	Description					
7	FREQ_LIMIT_PH_LOS	This bit determines whether the T0 DPLL in hard alarm status will result in it unlocked. 0: Disabled. 1: Enabled. (default)					
6 - 0	DPLL_FREQ_SOFT_LIMIT[6:0]	These bits represent an unsigned integer. If the value is multiplied by 0.724, the DPLL soft limit for T0 path in ppm will be gotten. The DPLL soft limit is symmetrical about zero.					

DPLL_FREQ_HARD_LIMIT[7:0]_CNFG - DPLL Hard Limit Configuration 1

Address: 66H Type: Read / Write Default Value: 10101011							
7	6	5	4	3	2	1	0
DPLL_FREQ_HARD_LIMIT7	DPLL_FREQ_HARD_LIMIT6	DPLL_FREQ_HARD_LIMIT5	DPLL_FREQ_HARD_LIMIT4	DPLL_FREQ_HARD_LIMIT3	DPLL_FREQ_HARD_LIMIT2	DPLL_FREQ_HARD_LIMIT1	DPLL_FREQ_HARD_LIMIT0
Bit	Name	Description					
7 - 0	DPLL_FREQ_HARD_LIMIT[7:0]	Refer to the description of the DPLL_FREQ_HARD_LIMIT[15:8] bits (b7~0, 67H).					

DPLL_FREQ_HARD_LIMIT[15:8]_CNFG - DPLL Hard Limit Configuration 2

Address: 67H Type: Read / Write Default Value: 00011001							
7	6	5	4	3	2	1	0
DPLL_FREQ_HARD_LIMIT15	DPLL_FREQ_HARD_LIMIT14	DPLL_FREQ_HARD_LIMIT13	DPLL_FREQ_HARD_LIMIT12	DPLL_FREQ_HARD_LIMIT11	DPLL_FREQ_HARD_LIMIT10	DPLL_FREQ_HARD_LIMIT9	DPLL_FREQ_HARD_LIMIT8
Bit	Name	Description					
7 - 0	DPLL_FREQ_HARD_LIMIT[15:8]	The DPLL_FREQ_HARD_LIMIT[15:0] bits represent an unsigned integer. If the value is multiplied by 0.0014, the DPLL hard limit for T0 path in ppm will be gotten. The DPLL hard limit is symmetrical about zero.					

CURRENT_DPLL_PHASE[7:0]_STS - DPLL Current Phase Status 1 *

Address: 68H Type: Read Default Value: 00000000							
7	6	5	4	3	2	1	0
CURRENT_PH_DATA7	CURRENT_PH_DATA6	CURRENT_PH_DATA5	CURRENT_PH_DATA4	CURRENT_PH_DATA3	CURRENT_PH_DATA2	CURRENT_PH_DATA1	CURRENT_PH_DATA0
Bit	Name	Description					
7 - 0	CURRENT_PH_DATA[7:0]	Refer to the description of the CURRENT_PH_DATA[15:8] bits (b7~0, 69H).					

CURRENT_DPLL_PHASE[15:8]_STS - DPLL Current Phase Status 2 *

Address: 69H Type: Read Default Value: 00000000							
7	6	5	4	3	2	1	0
CURRENT_PH_DATA15	CURRENT_PH_DATA14	CURRENT_PH_DATA13	CURRENT_PH_DATA12	CURRENT_PH_DATA11	CURRENT_PH_DATA10	CURRENT_PH_DATA9	CURRENT_PH_DATA8
Bit	Name	Description					
7 - 0	CURRENT_PH_DATA[15:8]	The CURRENT_PH_DATA[15:0] bits represent a 2's complement signed integer. If the value is multiplied by 0.61, the averaged phase error of the T0 DPLL feedback with respect to the selected input clock in ns will be gotten.					

T0_T4_APLL_BW_CNFG - T0 / T4 APLL Bandwidth Configuration

Address: 6AH Type: Read / Write Default Value: XX01XX01							
7	6	5	4	3	2	1	0
-	-	T0_APLL_BW1	T0_APLL_BW0	-	-	T4_APLL_BW1	T4_APLL_BW0
Bit	Name	Description					
7 - 6	-	Reserved.					
5 - 4	T0_APLL_BW[1:0]	These bits set the bandwidth for T0 APLL. 00: 100 kHz. 01: 500 kHz. (default) 10: 1 MHz. 11: 2 MHz.					
3 - 2	-	Reserved.					
1 - 0	T4_APLL_BW[1:0]	These bits set the bandwidth for T4 APLL. 00: 100 kHz. 01: 500 kHz. (default) 10: 1 MHz. 11: 2 MHz.					

6.2.8 OUTPUT CONFIGURATION REGISTERS

OUT2_FREQ_CNFG - Output Clock 2 Frequency Configuration

Address: 6DH							
Type: Read / Write							
Default Value: 00001000							
7	6	5	4	3	2	1	0
OUT2_PATH_S EL3	OUT2_PATH_S EL2	OUT2_PATH_S EL1	OUT2_PATH_S EL0	OUT2_DIVIDER 3	OUT2_DIVIDER 2	OUT2_DIVIDER 1	OUT2_DIVIDER 0
Bit	Name	Description					
7 - 4	OUT2_PATH_SEL[3:0]	These bits select an input to OUT2. 0000 ~ 0011: The output of T0 APLL. (default: 0000) 0100: The output of T0 DPLL 77.76 MHz path. 0101: The output of T0 DPLL 12E1/24T1/E3/T3 path. 0110: The output of T0 DPLL 16E1/16T1 path. 0111: The output of T0 DPLL ETH/OBSAI/16E1/16T1 path. 1000 ~ 1011: The output of T4 APLL. 1100 ~ 1111: Reserved.					
3 - 0	OUT2_DIVIDER[3:0]	These bits select a division factor of the divider for OUT2. The output frequency is determined by the division factor and the signal derived from T0 DPLL or T0/T4 APLL output (selected by the OUT2_PATH_SEL[3:0] bits (b7~4, 6DH)). If the signal is derived from one of the T0 DPLL outputs, please refer to Table 20 for the division factor selection. If the signal is derived from the T0/T4 APLL output, please refer to Table 21~Table 22 for the division factor selection.					

OUT1_FREQ_CNFG - Output Clock 1 Frequency Configuration

Address: 71H							
Type: Read / Write							
Default Value: 00001000							
7	6	5	4	3	2	1	0
OUT1_PATH_S EL3	OUT1_PATH_S EL2	OUT1_PATH_S EL1	OUT1_PATH_S EL0	OUT1_DIVIDER 3	OUT1_DIVIDER 2	OUT1_DIVIDER 1	OUT1_DIVIDER 0
Bit	Name	Description					
7 - 4	OUT1_PATH_SEL[3:0]	These bits select an input to OUT1. 0000 ~ 0011: The output of T0 APLL. (default: 0000) 0100: The output of T0 DPLL 77.76 MHz path. 0101: The output of T0 DPLL 12E1/24T1/E3/T3 path. 0110: The output of T0 DPLL 16E1/16T1 path. 0111: The output of T0 DPLL ETH/OBSAI/16E1/16T1 path. 1000 ~ 1011: The output of T4 APLL. 1100 ~ 1111: Reserved.					
3 - 0	OUT1_DIVIDER[3:0]	These bits select a division factor of the divider for OUT1. The output frequency is determined by the division factor and the signal derived from T0 DPLL or T0/T4 APLL output (selected by the OUT1_PATH_SEL[3:0] bits (b7~4, 71H)). If the signal is derived from one of the T0 DPLL outputs, please refer to Table 20 for the division factor selection. If the signal is derived from the T0/T4 APLL output, please refer to Table 21~Table 22 for the division factor selection.					

OUT1_INV_CNFG - Output Clock 1 Invert Configuration

Address:72H Type: Read / Write Default Value: XXXXXX0X							
7	6	5	4	3	2	1	0
-	-	-	-	-	-	OUT1_INV	-
Bit	Name	Description					
7 - 2	-	Reserved.					
1	OUT1_INV	This bit determines whether the output on OUT1 is inverted. 0: Not inverted. (default) 1: Inverted.					
0	-	Reserved.					

OUT2_INV_CNFG - Output Clock 2 Invert Configuration

Address:73H Type: Read / Write Default Value: XXXXX0XX							
7	6	5	4	3	2	1	0
-	-	-	-	-	OUT2_INV	-	-
Bit	Name	Description					
7 - 3	-	Reserved.					
2	OUT2_INV	This bit determines whether the output on OUT2 is inverted. 0: Not inverted. (default) 1: Inverted.					
1 - 0	-	Reserved.					

FR_MFR_SYNC_CNFG - Frame Sync & Multiframe Sync Output Configuration

Address:74H							
Type: Read / Write							
Default Value: 01100000							
7	6	5	4	3	2	1	0
IN_2K_4K_8K_INV	8K_EN	2K_EN	2K_8K_PUL_POSITION	8K_INV	8K_PUL	2K_INV	2K_PUL
Bit	Name	Description					
7	IN_2K_4K_8K_INV	This bit determines whether the input clock is inverted before locked by the T0 DPLL when the input clock is 2 kHz, 4 kHz or 8 kHz. 0: Not inverted. (default) 1: Inverted.					
6	8K_EN	This bit determines whether an 8 kHz signal is enabled to be output on FRSYNC_8K. 0: Disabled. FRSYNC_8K outputs low. 1: Enabled. (default)					
5	2K_EN	This bit determines whether a 2 kHz signal is enabled to be output on MFRSYNC_2K. 0: Disabled. MFRSYNC_2K outputs low. 1: Enabled. (default)					
4	2K_8K_PUL_POSITION	This bit is valid only when FRSYNC_8K and/or MFRSYNC_2K output pulse; i.e., when one of the 8K_PUL bit (b2, 74H) and the 2K_PUL bit (b0, 74H) is '1' or when the 8K_PUL bit (b2, 74H) and the 2K_PUL bit (b0, 74H) are both '1'. It determines the pulse position referring to the standard 50:50 duty cycle. 0: Pulsed on the falling edge of the standard 50:50 duty cycle position. (default) 1: Pulsed on the rising edge of the standard 50:50 duty cycle position.					
3	8K_INV	This bit determines whether the output on FRSYNC_8K is inverted. 0: Not inverted. (default) 1: Inverted.					
2	8K_PUL	This bit determines whether the output on FRSYNC_8K is 50:50 duty cycle or pulsed. 0: 50:50 duty cycle. (default) 1: Pulsed. The pulse width is defined by the period of the output on OUT2.					
1	2K_INV	This bit determines whether the output on MFRSYNC_2K is inverted. 0: Not inverted. (default) 1: Inverted.					
0	2K_PUL	This bit determines whether the output on MFRSYNC_2K is 50:50 duty cycle or pulsed. 0: 50:50 duty cycle. (default) 1: Pulsed. The pulse width is defined by the period of the output on OUT2.					

6.2.9 PBO & PHASE OFFSET CONTROL REGISTERS

PHASE_MON_PBO_CNFG - Phase Transient Monitor & PBO Configuration

Address:78H Type: Read / Write Default Value: 0X000110							
7	6	5	4	3	2	1	0
IN_NOISE_WIN DOW	-	PH_MON_EN	PH_MON_PBO _EN	PH_TR_MON_L IMT3	PH_TR_MON_L IMT2	PH_TR_MON_L IMT1	PH_TR_MON_L IMT0
Bit	Name	Description					
7	IN_NOISE_WINDOW	This bit determines whether the input clock whose edge respect to the reference clock is outside ±5% is enabled to be selected for T0 DPLL. 0: Disabled. (default) 1: Enabled.					
6	-	Reserved.					
5	PH_MON_EN	This bit is valid only when the PH_MON_PBO_EN bit (b4, 78H) is '1'. It determines whether the Phase Transient Monitor is enabled to monitor the phase-time changes on the T0 selected input clock. 0: Disabled. (default) 1: Enabled.					
4	PH_MON_PBO_EN	This bit determines whether a PBO event is triggered when the phase-time changes on the T0 selected input clock are greater than a programmable limit over an interval of less than 0.1 seconds with the PH_MON_EN bit being '1'. The limit is programmed by the PH_TR_MON_LIMT[3:0] bits (b3~0, 78H). 0: Disabled. (default) 1: Enabled.					
3 - 0	PH_TR_MON_LIMT[3:0]	These bits represent an unsigned integer. The Phase Transient Monitor limit in ns can be calculated as follows: Limit (ns) = (PH_TR_MON_LIMT[3:0] + 7) X 156.					

PHASE_OFFSET[7:0]_CNFG - Phase Offset Configuration 1

Address:7AH Type: Read / Write Default Value: 00000000							
7	6	5	4	3	2	1	0
PH_OFFSET7	PH_OFFSET6	PH_OFFSET5	PH_OFFSET4	PH_OFFSET3	PH_OFFSET2	PH_OFFSET1	PH_OFFSET0
Bit	Name	Description					
7 - 0	PH_OFFSET[7:0]	Refer to the description of the PH_OFFSET[9:8] bits (b1~0, 7BH).					

PHASE_OFFSET[9:8]_CNFG - Phase Offset Configuration 2

Address: 7BH
 Type: Read / Write
 Default Value: 0XXXXX00

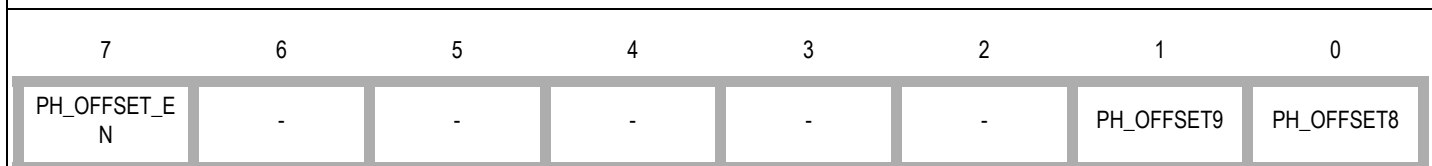

Bit	Name	Description
7	PH_OFFSET_EN	This bit determines whether the input-to-output phase offset is enabled. 0: Disabled. (default) 1: Enabled.
6 - 2	-	Reserved.
1 - 0	PH_OFFSET[9:8]	These bits represent a 2's complement signed integer. If the value is multiplied by 0.61, the input-to-output phase offset in ns to adjust will be gotten.

6.2.10 SYNCHRONIZATION CONFIGURATION REGISTERS

SYNC_MONITOR_CNFG - Sync Monitor Configuration

Address: 7CH							
Type: Read / Write							
Default Value: 00101011							
7	6	5	4	3	2	1	0
SYNC_BYPASS	SYNC_MON_LIMT2	SYNC_MON_LIMT1	SYNC_MON_LIMT0	-	-	-	-
Bit	Name	Description					
7	SYNC_BYPASS	This bit selects one frame sync input signal to synchronize the frame sync output signals. 0: EX_SYNC1 is selected. (default) 1: When the T0 selected input clock is IN1_CMOS or IN1_DIFF, EX_SYNC1 is selected; when the T0 selected input clock is IN2_CMOS or IN2_DIFF, EX_SYNC2 is selected; when the T0 selected input clock is IN3_CMOS, EX_SYNC3 is selected; when there is no T0 selected input clock, no frame sync input signal is selected.					
6 - 4	SYNC_MON_LIMT[2:0]	These bits set the limit for the external sync alarm. 000: ±1 UI. 001: ±2 UI. 010: ±3 UI. (default) 011: ±4 UI. 100: ±5 UI. 101: ±6 UI. 110: ±7 UI. 111: ±8 UI.					
3 - 0	-	These bits must be set to '1011'.					

SYNC_PHASE_CNFG - Sync Phase Configuration

Address: 7DH							
Type: Read / Write							
Default Value: XX000000							
7	6	5	4	3	2	1	0
-	-	SYNC_PH31	SYNC_PH30	SYNC_PH21	SYNC_PH20	SYNC_PH11	SYNC_PH10
Bit	Name	Description					
7 - 6	-	Reserved.					
5 - 4	SYNC_PH3[1:0]	These bits set the sampling of EX_SYNC3 when EX_SYNC3 is enabled to synchronize the frame sync output signal. Nominally, the falling edge of EX_SYNC3 is aligned with the rising edge of the T0 selected input clock. 00: On target. (default) 01: 0.5 UI early. 10: 1 UI late. 11: 0.5 UI late.					
3 - 2	SYNC_PH2[1:0]	These bits set the sampling of EX_SYNC2 when EX_SYNC2 is enabled to synchronize the frame sync output signal. Nominally, the falling edge of EX_SYNC2 is aligned with the rising edge of the T0 selected input clock. 00: On target. (default) 01: 0.5 UI early. 10: 1 UI late. 11: 0.5 UI late.					
1 - 0	SYNC_PH1[1:0]	These bits set the sampling of EX_SYNC1 when EX_SYNC1 is enabled to synchronize the frame sync output signal. Nominally, the falling edge of EX_SYNC1 is aligned with the rising edge of the T0 selected input clock. 00: On target. (default) 01: 0.5 UI early. 10: 1 UI late. 11: 0.5 UI late.					

7 THERMAL MANAGEMENT

The device operates over the industry temperature range -40°C ~ +85°C. To ensure the functionality and reliability of the device, the maximum junction temperature T_{jmax} should not exceed 125°C. In some applications, the device will consume more power and a thermal solution should be provided to ensure the junction temperature T_j does not exceed the T_{jmax} .

7.1 JUNCTION TEMPERATURE

Junction temperature T_j is the temperature of package typically at the geographical center of the chip where the device's electrical circuits are. It can be calculated as follows:

$$\text{Equation 1: } T_j = T_A + P \times \theta_{JA}$$

Where:

θ_{JA} = Junction-to-Ambient Thermal Resistance of the Package

T_j = Junction Temperature

T_A = Ambient Temperature

P = Device Power Consumption

In order to calculate junction temperature, an appropriate θ_{JA} must be used. The θ_{JA} is shown in Table 32:

Power consumption is the core power excluding the power dissipated in the loads. Table 31 provides power consumption in special environments.

Table 31: Power Consumption and Maximum Junction Temperature

Package	Power Consumption (W)	Operating Voltage (V)	T_A (°C)	Maximum Junction Temperature (°C)
LQFP/PP64	1.57	3.6	85	125
TQFP/EDG64	1.57	3.6	85	125

7.2 EXAMPLE OF JUNCTION TEMPERATURE CALCULATION

Assume:

$$T_A = 85^\circ\text{C}$$

$$\theta_{JA} = 21.7^\circ\text{C/W (TQFP/EDG64 Soldered \& when airflow rate is 0 m/s)}$$

$$P = 1.57\text{W}$$

Table 32: Thermal Data

Package	Pin Count	Thermal Pad	θ_{JC} (°C/W)	θ_{JB} (°C/W)	θ_{JA} (°C/W) Air Flow in m/s					
					0	1	2	3	4	5
LQFP/PP64	64	No	12.3	35.1	43.1	40	38.1	37.3	36.5	36.1
TQFP/EDG64	64	Yes/Exposed	12.6	35.3	37.0	32.1	30.4	29.4	28.7	28.1
TQFP/EDG64	64	Yes/Soldered	12.6	1.3	21.7	17.3	16.2	15.6	15.2	14.9

The junction temperature T_j can be calculated as follows:

$$T_j = T_A + P \times \theta_{JA} = 85^\circ\text{C} + 1.57\text{W} \times 21.7^\circ\text{C/W} = 119.1^\circ\text{C}$$

The junction temperature of 119.1°C is below the maximum junction temperature of 125°C so no extra heat enhancement is required.

In some operation environments, the calculated junction temperature might exceed the maximum junction temperature of 125°C and an external thermal solution such as a heatsink is required.

7.3 HEATSINK EVALUATION

A heatsink is expanding the surface area of the device to which it is attached. θ_{JA} is now a combination of device case and heat-sink thermal resistance, as the heat flowing from the die junction to ambient goes through the package and the heatsink. θ_{JA} can be calculated as follows:

$$\text{Equation 2: } \theta_{JA} = \theta_{JC} + \theta_{CH} + \theta_{HA}$$

Where:

θ_{JC} = Junction-to-Case Thermal Resistance

θ_{CH} = Case-to-Heatsink Thermal Resistance

θ_{HA} = Heatsink-to-Ambient Thermal Resistance

$\theta_{CH} + \theta_{HA}$ determines which heatsink and heatsink attachment can be selected to ensure the junction temperature does not exceed the maximum junction temperature. According to Equation 1 and 2,

$\theta_{CH} + \theta_{HA}$ can be calculated as follows:

$$\text{Equation 3: } \theta_{CH} + \theta_{HA} = (T_j - T_A) / P - \theta_{JC}$$

Assume:

$$T_j = 125^\circ\text{C (} T_{jmax} \text{)}$$

$$T_A = 85^\circ\text{C}$$

$$P = 1.57\text{W}$$

$$\theta_{JC} = 12.6^\circ\text{C/W (TQFP/EDG64)}$$

$\theta_{CH} + \theta_{HA}$ can be calculated as follows:

$$\theta_{CH} + \theta_{HA} = (125^\circ\text{C} - 85^\circ\text{C}) / 1.57\text{W} - 12.6^\circ\text{C/W} = 12.9^\circ\text{C/W}$$

That is, if a heatsink and heatsink attachment whose $\theta_{CH} + \theta_{HA}$ is below or equal to 12.9°C/W is used in such operation environment, the junction temperature will not exceed the maximum junction temperature.

8 ELECTRICAL SPECIFICATIONS

8.1 ABSOLUTE MAXIMUM RATING

Table 33: Absolute Maximum Rating

Symbol	Parameter	Min	Max	Unit
V_{DD}	Supply Voltage VDD	-0.5	3.6	V
V_{IN}	Input Voltage (non-supply pins)		5.5	V
V_{OUT}	Output Voltage (non-supply pins)		5.5	V
T_A	Ambient Operating Temperature Range	-40	+85	°C
T_{STOR}	Storage Temperature	-50	+150	°C

8.2 RECOMMENDED OPERATION CONDITIONS

Table 34: Recommended Operation Conditions

Symbol	Parameter	Min	Typ	Max	Unit	Test Condition
V_{DD}	Power Supply (DC voltage) VDD	3.0	3.3	3.6	V	
T_A	Ambient Temperature Range	-40		+85	°C	
I_{DD}	Supply Current		388	436	mA	Exclude the loading current and power
P_{TOT}	Total Power Dissipation		1.28	1.57	W	

8.3 I/O SPECIFICATIONS

8.3.1 CMOS INPUT / OUTPUT PORT

From Table 35 to Table 38, V_{DD} is 3.3 V.

Table 35: CMOS Input Port Electrical Characteristics

Parameter	Description	Min	Typ	Max	Unit	Test Condition
V_{IH}	Input Voltage High	$0.7V_{DD}$			V	
V_{IL}	Input Voltage Low			$0.2V_{DD}$	V	
I_{IN}	Input Current			10	μA	
V_{IN}	Input Voltage	-0.5		5.5	V	

Table 36: CMOS Input Port with Internal Pull-Up Resistor Electrical Characteristics

Parameter	Description	Min	Typ	Max	Unit	Test Condition
V_{IH}	Input Voltage High	$0.7V_{DD}$			V	
V_{IL}	Input Voltage Low			$0.2V_{DD}$	V	
P_U	Pull-Up Resistor	10		80	$K\Omega$	
I_{IN}	Input Current			250	μA	
V_{IN}	Input Voltage	-0.5		5.5	V	

Table 37: CMOS Input Port with Internal Pull-Down Resistor Electrical Characteristics

Parameter	Description	Min	Typ	Max	Unit	Test Condition
V_{IH}	Input Voltage High	$0.7V_{DD}$			V	
V_{IL}	Input Voltage Low			$0.2V_{DD}$	V	
P_D	Pull-Down Resistor	10		80	$K\Omega$	other CMOS input port with internal pull-down resistor
		5		40		TRST and TCK pin
		100		300		SDI, CLKE pin
I_{IN}	Input Current			350	μA	other CMOS input port with internal pull-down resistor
				700		TRST and TCK pin
				40		SDI, CLKE pin
V_{IN}	Input Voltage	-0.5		5.5	V	

Table 38: CMOS Output Port Electrical Characteristics

Application Pin	Parameter	Description	Min	Typ	Max	Unit	Test Condition
Output Clock	V_{OH}	Output Voltage High	2.4		V_{DD}	V	$I_{OH} = 8 \text{ mA}$
	V_{OL}	Output Voltage Low	0		0.4	V	$I_{OL} = 8 \text{ mA}$
	t_R	Rise time		3	4	ns	15 pF
	t_F	Fall time		3	4	ns	15 pF
Other Output	V_{OH}	Output Voltage High	2.5		V_{DD}	V	$I_{OH} = 4 \text{ mA}$
	V_{OL}	Output Voltage Low	0		0.4	V	$I_{OL} = 4 \text{ mA}$
	t_R	Rise Time			10	ns	50 pF
	t_F	Fall Time			10	ns	50 pF

8.3.2 PECL / LVDS INPUT / OUTPUT PORT

8.3.2.1 PECL Input / Output Port

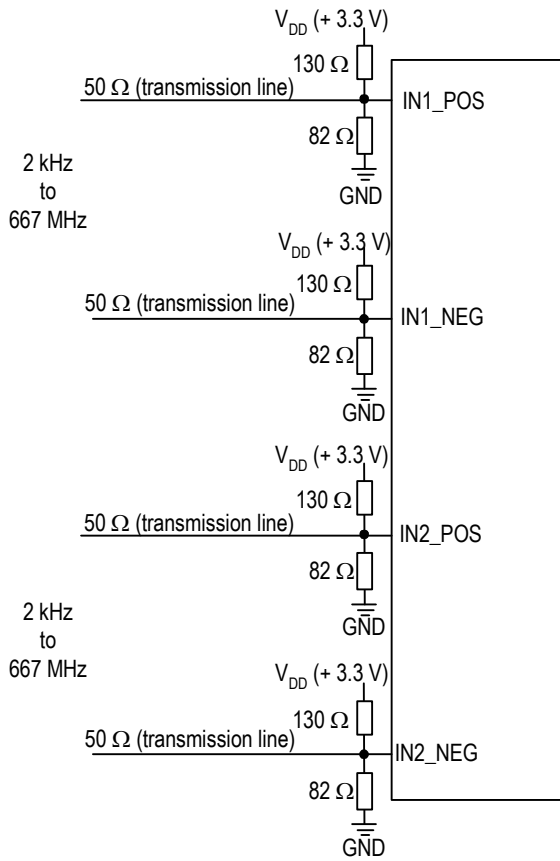

Figure 17. Recommended PECL Input Port Line Termination

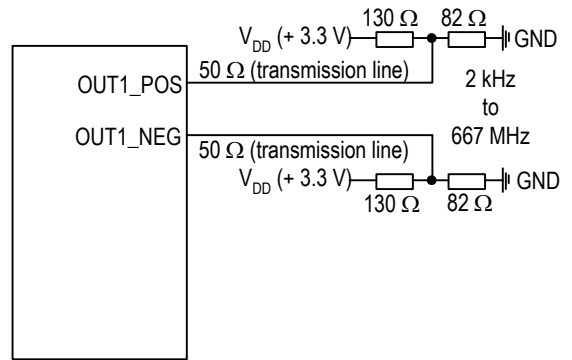

Figure 18. Recommended PECL Output Port Line Termination

Table 39: PECL Input / Output Port Electrical Characteristics

Parameter	Description	Min	Typ	Max	Unit	Test Condition
V_{IL}	Input Low Voltage, Differential Inputs ¹	$V_{DD} - 2.5$		$V_{DD} - 0.5$	V	
V_{IH}	Input High Voltage, Differential Inputs ¹	$V_{DD} - 2.4$		$V_{DD} - 0.4$	V	
V_{ID}	Input Differential Voltage	0.1		1.4	V	
V_{IL_S}	Input Low Voltage, Single-ended Input ²	$V_{DD} - 2.4$		$V_{DD} - 1.5$	V	
V_{IH_S}	Input High Voltage, Single-ended Input ²	$V_{DD} - 1.3$		$V_{DD} - 0.5$	V	
I_{IH}	Input High Current, Input Differential Voltage $V_{ID} = 1.4$ V	-10		10	μ A	
I_{IL}	Input Low Current, Input Differential Voltage $V_{ID} = 1.4$ V	-10		10	μ A	
V_{OL}	Output Voltage Low ³	$V_{DD} - 2.1$		$V_{DD} - 1.62$	V	
V_{OH}	Output Voltage High ³	$V_{DD} - 1.25$		$V_{DD} - 0.88$	V	
V_{OD}	Output Differential Voltage ³	580		900	mV	
t_{RISE}	Output Rise time (20% to 80%)	200		300	pS	
t_{FALL}	Output Fall time (20% to 80%)	200		300	pS	
t_{SKEW}	Output Differential Skew			50	pS	

Note:

1. Assuming a differential input voltage of at least 100 mV.
2. Unused differential input terminated to $V_{DD}-1.4$ V.
3. With 50 Ω load on each pin to $V_{DD}-2$ V, i.e. 82 to GND and 130 to V_{DD} .

8.3.2.2 LVDS Input / Output Port

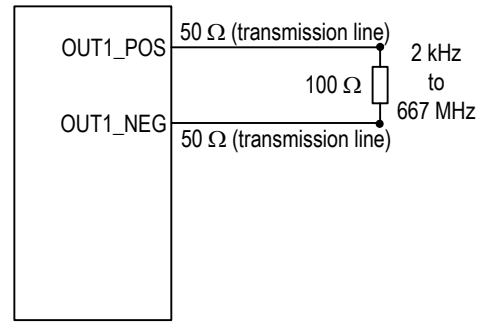
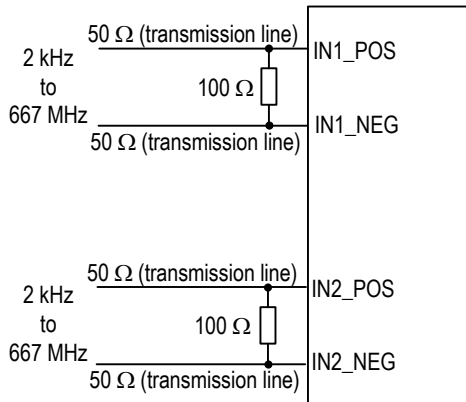

Figure 20. Recommended LVDS Output Port Line Termination

Figure 19. Recommended LVDS Input Port Line Termination

Table 40: LVDS Input / Output Port Electrical Characteristics

Parameter	Description	Min	Typ	Max	Unit	Test Condition
V_{CM}	Input Common-mode Voltage Range	0	1200	2400	mV	
V_{DIFF}	Input Peak Differential Voltage	100		900	mV	
V_{IDTH}	Input Differential Threshold	-100		100	mV	
R_{TERM}	External Differential Termination Impedance	95	100	105	Ω	
V_{OH}	Output Voltage High	1350		1475	mV	$R_{LOAD} = 100 \Omega \pm 1\%$
V_{OL}	Output Voltage Low	925		1100	mV	$R_{LOAD} = 100 \Omega \pm 1\%$
V_{OD}	Differential Output Voltage	250		400	mV	$R_{LOAD} = 100 \Omega \pm 1\%$
V_{OS}	Output Offset Voltage	1125		1275	mV	$R_{LOAD} = 100 \Omega \pm 1\%$
R_O	Differential Output Impedance	80	100	120	Ω	$V_{CM} = 1.0 V$ or $1.4 V$
ΔR_O	R_O Mismatch between A and B			20	%	$V_{CM} = 1.0 V$ or $1.4 V$
ΔV_{OD}	Change in V_{OD} between Logic 0 and Logic 1			25	mV	$R_{LOAD} = 100 \Omega \pm 1\%$
ΔV_{OS}	Change in V_{OS} between Logic 0 and Logic 1			25	mV	$R_{LOAD} = 100 \Omega \pm 1\%$
I_{SA}, I_{SB}	Output Current			24	mA	Driver shorted to GND
I_{SAB}	Output Current			12	mA	Driver shorted together
t_{RISE}	Output Rise time (20% to 80%)	200		300	pS	$R_{LOAD} = 100 \Omega \pm 1\%$
t_{FALL}	Output Fall time (20% to 80%)	200		300	pS	$R_{LOAD} = 100 \Omega \pm 1\%$
t_{SKEW}	Output Differential Skew			50	pS	$R_{LOAD} = 100 \Omega \pm 1\%$

8.4 JITTER & WANDER PERFORMANCE

Table 41: Output Clock Jitter Generation

Test Definition ¹	Peak to Peak Typ	RMS Typ	Note	Test Filter
25 MHz with T4 APLL	<1 ns	16 ps	See Table 42: Output Clock Phase Noise for details	1.875 MHz - 20 MHz
	<1 ns	22 ps	See Table 42: Output Clock Phase Noise for details	12 kHz - 20 MHz
125 MHz with T4 APLL	<1 ns	4.3 ps	See Table 42: Output Clock Phase Noise for details	1.875 MHz - 20 MHz
	<1 ns	15 ps	See Table 42: Output Clock Phase Noise for details	12 kHz - 20 MHz
156.25 MHz with T4 APLL	<1 ns	6.9 ps	See Table 42: Output Clock Phase Noise for details	1.875 MHz - 20 MHz
	<1 ns	25 ps	See Table 42: Output Clock Phase Noise for details	12 kHz - 20 MHz
N x 2.048 MHz without APLL	<2 ns	<200 ps		20 Hz - 100 kHz
N x 2.048 MHz with T0/T4 APLL	<1 ns	<100 ps	See Table 42: Output Clock Phase Noise for details	20 Hz - 100 kHz
N x 1.544 MHz without APLL	<2 ns	<200 ps		10 Hz - 40 kHz
N x 1.544 MHz with T0/T4 APLL	<1 ns	<100 ps	See Table 42: Output Clock Phase Noise for details	10 Hz - 40 kHz
44.736 MHz without APLL	<2 ns	<200 ps	See Table 42: Output Clock Phase Noise for details	100 Hz - 800 kHz
44.736 MHz with T0/T4 APLL	<1 ns	<100 ps		100 Hz - 800 kHz
34.368 MHz without APLL	<2 ns	<200 ps	See Table 42: Output Clock Phase Noise for details	10 Hz - 400 kHz
34.368 MHz with T0/T4 APLL	<1 ns	<100 ps		10 Hz - 400 kHz
62.5 MHz with T4 APLL	<1 ns	4.6 ps	See Table 42: Output Clock Phase Noise for details	1.875 MHz - 20 MHz
OC-3 (Chip T0 DPLL + T0/T4 APLL) 6.48 MHz, 19.44 MHz, 25.92 MHz, 38.88 MHz, 51.84 MHz, 77.76 MHz, 155.52 MHz, 311.04 MHz, 622.08 MHz output	0.004 UI p-p	0.001 UI RMS	GR-253, G.813 Option 2 limit 0.1 UI p-p (1 UI-6430 ps)	12 kHz - 1.3 MHz
	0.004 UI p-p	0.001 UI RMS	G.813 Option 1, G.812 limit 0.5 UI p-p (1 UI-6430 ps)	500 Hz - 1.3 MHz
	0.001 UI p-p	0.001 UI RMS	G.813 Option 1 limit 0.1 UI p-p (1 UI-6430 ps)	65 kHz - 1.3 MHz
OC-12 (Chip T0 DPLL + T0/T4 APLL) 6.48 MHz, 19.44 MHz, 25.92 MHz, 38.88 MHz, 51.84 MHz, 77.76 MHz, 155.52 MHz, 311.04 MHz, 622.08 MHz output + Intel GD16523 + Optical transceiver)	0.018 UI p-p	0.007 UI RMS	GR-253, G.813 Option 2 limit 0.1 UI p-p (1 UI-1608 ps)	12 kHz - 5 MHz
	0.028 UI p-p	0.009 UI RMS	G.813 Option 1, G.812 limit 0.5 UI p-p (1 UI-1608 ps)	1 kHz - 5 MHz
	0.002 UI p-p	0.001 UI RMS	G.813 Option 1, G.812 limit 0.1 UI p-p (1 UI-1608 ps)	250 kHz - 5 MHz
STM-16 (Chip T0 DPLL + T0/T4 APLL) 6.48 MHz, 19.44 MHz, 25.92 MHz, 38.88 MHz, 51.84 MHz, 77.76 MHz, 155.52 MHz, 311.04 MHz, 622.08 MHz output + Intel GD16523 + Optical transceiver)	0.162 UI p-p	0.03 UI RMS	G.813 Option 1, G.812 limit 0.5 UI p-p (1 UI-402 ps)	5 kHz - 20 MHz
	0.01 UI p-p	0.009 UI RMS	G.813 Option 1, G.812 limit 0.1 UI p-p (1 UI-402 ps)	1 MHz - 20 MHz

Note:
1. CMAC E2747 TCXO is used.

Table 42: Output Clock Phase Noise

Output Clock ¹	@100Hz Offset Typ	@1kHz Offset Typ	@10kHz Offset Typ	@100kHz Offset Typ	@1MHz Offset Typ	@5MHz Offset Typ	Unit
622.08 MHz (T0 DPLL + T0/T4 APLL)	-70	-86	-95	-100	-107	-128	dBC/Hz
155.52 MHz (T0 DPLL + T0/T4 APLL)	-82	-98	-107	-112	-119	-140	dBC/Hz
25 MHz (T0 DPLL + T4 APLL)	-105	-117	-116	-122	-131	-135	dBC/Hz
125 MHz (T0 DPLL + T4 APLL)	-92	-100	-103	-107	-116	-135	dBC/Hz
156.25 MHz (T0 DPLL + T4 APLL)	-93	-102	-100	-105	-115	-127	dBC/Hz
38.88 MHz (T0 DPLL + T0/T4 APLL)	-104	-116	-118	-123	-129	-149	dBC/Hz
62.5 MHz (T0 DPLL + T4 APLL)	-100	-110	-110	-114	-123	-132	dBC/Hz
16E1 (T0/T4 APLL)	-103	-117	-118	-125	-130	-139	dBC/Hz
16T1 (T0/T4 APLL)	-114	-121	-120	-126	-130	-140	dBC/Hz
E3 (T0/T4 APLL)	-107	-119	-117	-123	-129	-139	dBC/Hz
T3 (T0/T4 APLL)	-106	-115	-115	-121	-128	-139	dBC/Hz

Note:

1. CMAC E2747 TCXO is used.

Table 43: Input Jitter Tolerance (155.52 MHz)

Jitter Frequency	Jitter Tolerance Amplitude (UI p-p)
12 μ Hz	> 2800
178 μ Hz	> 2800
1.6 mHz	> 311
15.6 mHz	> 311
0.125 Hz	> 39
19.3 Hz	> 39
500 Hz	> 1.5
6.5 kHz	> 1.5
65 kHz	> 0.15
1.3 MHz	> 0.15

Table 44: Input Jitter Tolerance (1.544 MHz)

Jitter Frequency	Jitter Tolerance Amplitude (UI p-p)
1 Hz	150
5 Hz	140
20 Hz	130
300 Hz	38
400 Hz	25
700 Hz	15
2400 Hz	5
10 kHz	1.2
40 kHz	0.5

Table 45: Input Jitter Tolerance (2.048 MHz)

Jitter Frequency	Jitter Tolerance Amplitude (UI p-p)
1 Hz	150
5 Hz	140
20 Hz	130
300 Hz	40
400 Hz	33
700 Hz	18
2400 Hz	5.5
10 kHz	1.3
50 kHz	0.4
100 kHz	0.4

Table 46: Input Jitter Tolerance (8 kHz)

Jitter Frequency	Jitter Tolerance Amplitude (UI p-p)
1 Hz	0.8
5 Hz	0.7
20 Hz	0.6
300 Hz	0.16
400 Hz	0.14
700 Hz	0.07
2400 Hz	0.02
3600 Hz	0.01

Table 47: T0 DPLL Jitter Transfer & Damping Factor

3 dB Bandwidth	Programmable Damping Factor
0.1 Hz	1.2, 2.5, 5, 10, 20
0.3 Hz	1.2, 2.5, 5, 10, 20
0.6 Hz	1.2, 2.5, 5, 10, 20
1.2 Hz	1.2, 2.5, 5, 10, 20
2.5 Hz	1.2, 2.5, 5, 10, 20
4 Hz	1.2, 2.5, 5, 10, 20
8 Hz	1.2, 2.5, 5, 10, 20
18 Hz	1.2, 2.5, 5, 10, 20
35 Hz	1.2, 2.5, 5, 10, 20
70 Hz	1.2, 2.5, 5, 10, 20
560 Hz	1.2, 2.5, 5, 10, 20

8.5 OUTPUT WANDER GENERATION

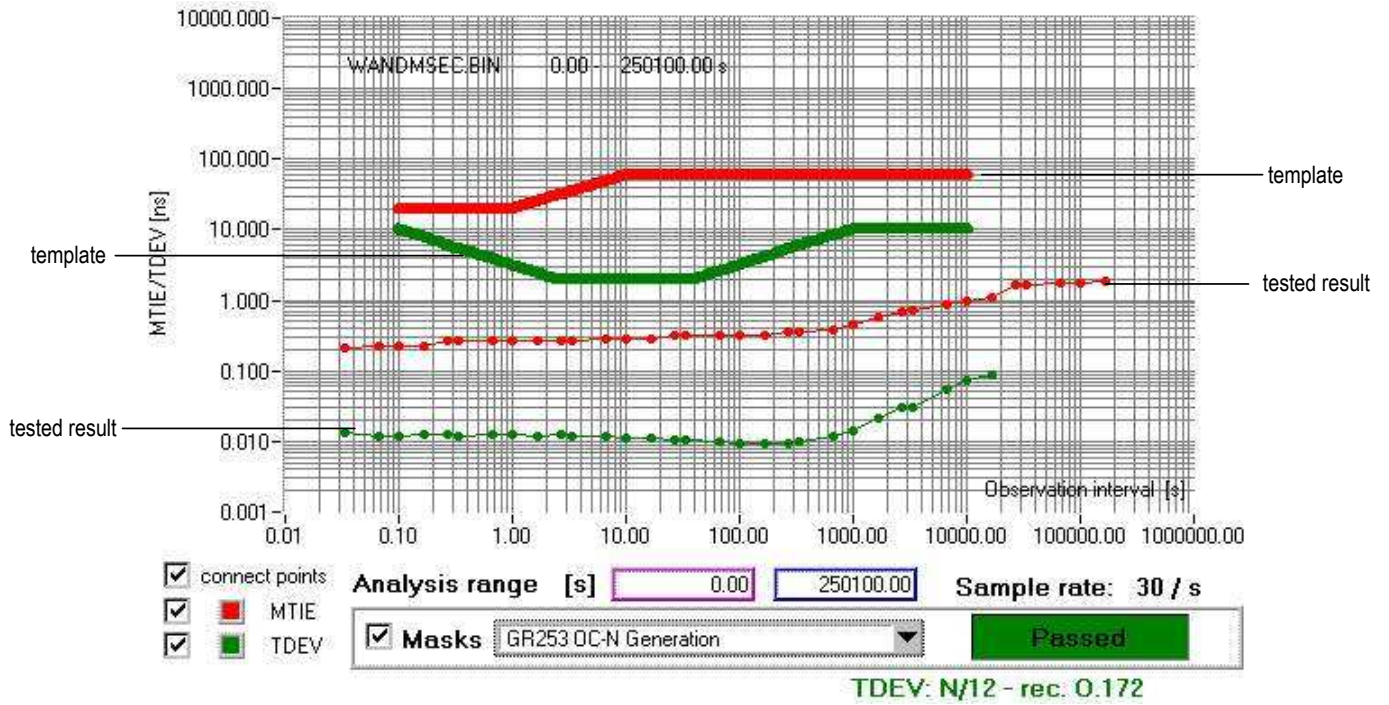

Figure 21. Output Wander Generation

8.6 INPUT / OUTPUT CLOCK TIMING

The inputs and outputs are aligned ideally. But due to the circuit delays, there is delay between the inputs and outputs.

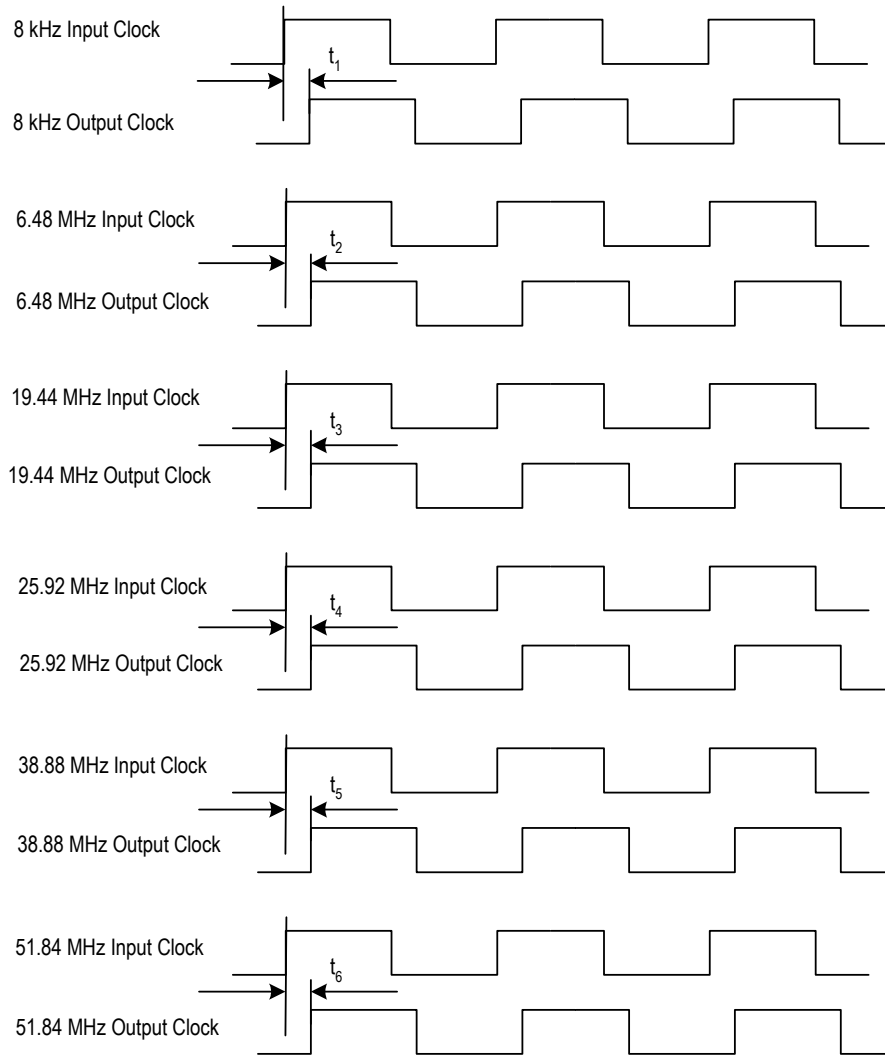

Figure 22. Input / Output Clock Timing

Table 48: Input/Output Clock Timing

Symbol	Typical Delay ¹ (ns)	Peak to Peak Delay Variation (ns)
t_1	4	1.6
t_2	1	1.6
t_3	1	1.6
t_4	2	1.6
t_5	1.4	1.6
t_6	3	1.6

Note:
1. Typical delay provided as reference only.

8.7 OUTPUT CLOCK TIMING

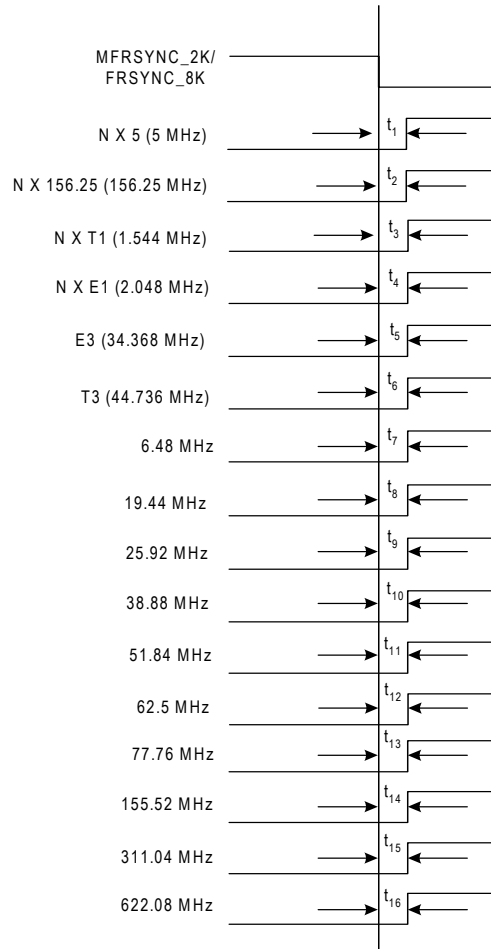

Table 49: Output Clock Timing

Symbol	Typical Delay (ns)	Peak to Peak Delay Variation (ns)
t_1	0	2
t_2	0	2
t_3	0	2
t_4	0	2
t_5	0	2
t_6	0	2
t_7	0	2
t_8	0	2
t_9	0	2
t_{10}	0	2
t_{11}	0	2
t_{12}	0	2
t_{13}	0	2
t_{14}	0	1.5
t_{15}	0	1.5 (not recommended to use)
t_{16}	0	1.5 (not recommended to use)



3G	---	Third Generation
ADSL	---	Asymmetric Digital Subscriber Line
AMI	---	Alternate Mark Inversion
APLL	---	Analog Phase Locked Loop
ATM	---	Asynchronous Transfer Mode
BITS	---	Building Integrated Timing Supply
CMOS	---	Complementary Metal-Oxide Semiconductor
DCO	---	Digital Controlled Oscillator
DPLL	---	Digital Phase Locked Loop
DSL	---	Digital Subscriber Line
DSLAM	---	Digital Subscriber Line Access MUX
DWDM	---	Dense Wavelength Division Multiplexing
EPROM	---	Erasable Programmable Read Only Memory
ETH	---	Synchronous Ethernet System
GPS	---	Global Positioning System
GSM	---	Global System for Mobile Communications
IIR	---	Infinite Impulse Response
IP	---	Internet Protocol
ISDN	---	Integrated Services Digital Network
JTAG	---	Joint Test Action Group
LOS	---	Loss Of Signal
LPF	---	Low Pass Filter
LVDS	---	Low Voltage Differential Signal
MTIE	---	Maximum Time Interval Error
MUX	---	Multiplexer
OBSAI	---	Open Base Station Architecture Initiative

OC-n	---	Optical Carried rate, n = 1, 3, 12, 48, 192, 768; 51 Mbit/s, 155 Mbit/s, 622 Mbit/s, 2.5 Gbit/s, 10 Gbit/s, 40 Gbit/s.
PBO	---	Phase Build-Out
PDH	---	Plesiochronous Digital Hierarchy
PECL	---	Positive Emitter Coupled Logic
PFD	---	Phase & Frequency Detector
PLL	---	Phase Locked Loop
RMS	---	Root Mean Square
PRS	---	Primary Reference Source
SDH	---	Synchronous Digital Hierarchy
SEC	---	SDH / SONET Equipment Clock
SMC	---	SONET Minimum Clock
SONET	---	Synchronous Optical Network
SSU	---	Synchronization Supply Unit
STM	---	Synchronous Transfer Mode
TCM-ISDN	---	Time Compression Multiplexing Integrated Services Digital Network
TDEV	---	Time Deviation
UI	---	Unit Interval
WLL	---	Wireless Local Loop



A			
Averaged Phase Error	28	Frequency Hard Alarm	19, 24
B		Frequency Hard Alarm Threshold	19
Bandwidths and Damping Factors	28	H	
Acquisition Bandwidth and Damping Factor	28	Hard Limit	22
Locked Bandwidth and Damping Factor	28	Holdover Frequency Offset	29
Starting Bandwidth and Damping Factor	28	I	
C		IIR	29
Calibration	15	Input Clock Frequency	19
Coarse Phase Loss	22	Input Clock Selection	20
Crystal Oscillator	15	Automatic selection	21, 24
Current Frequency Offset	28	External Fast selection	20, 24
D		Forced selection	21, 24
DCO	28	Internal Leaky Bucket Accumulator	18
Division Factor	17	Bucket Size	18
DPLL Hard Alarm	22	Decay Rate	18
DPLL Hard Limit	22	Lower Threshold	18
DPLL Operating Mode	28	Upper Threshold	18
Free-Run mode	28	L	
Holdover mode	28	Limit	30
Automatic Fast Averaged	29	LPF	28
Automatic Instantaneous	29	M	
Automatic Slow Averaged	29	Master Clock	15
Manual	29	Microprocessor Interface	39
Locked mode	28	N	
Temp-Holdover mode	28	No-activity Alarm	18, 24
Lost-Phase mode	28	P	
Pre-Locked mode	28	PBO	30
Pre-Locked2 mode	29	PFD	28
DPLL Soft Alarm	22	Phase Lock Alarm	22, 24
DPLL Soft Limit	22	Phase Offset	30
E		Phase-compared	22, 30
External Sync Alarm	34	Phase-time	30
F		Pre-Divider	17
Fast Loss	22	DivN Divider	17
Fine Phase Loss	22		

HF Divider	17	Non-Revertive switch	24
Lock 8k Divider	17	Revertive switch	24
R		State Machine	26
Reference Clock	19	V	
S		Validity	24
Selected Input Clock Switch	24		

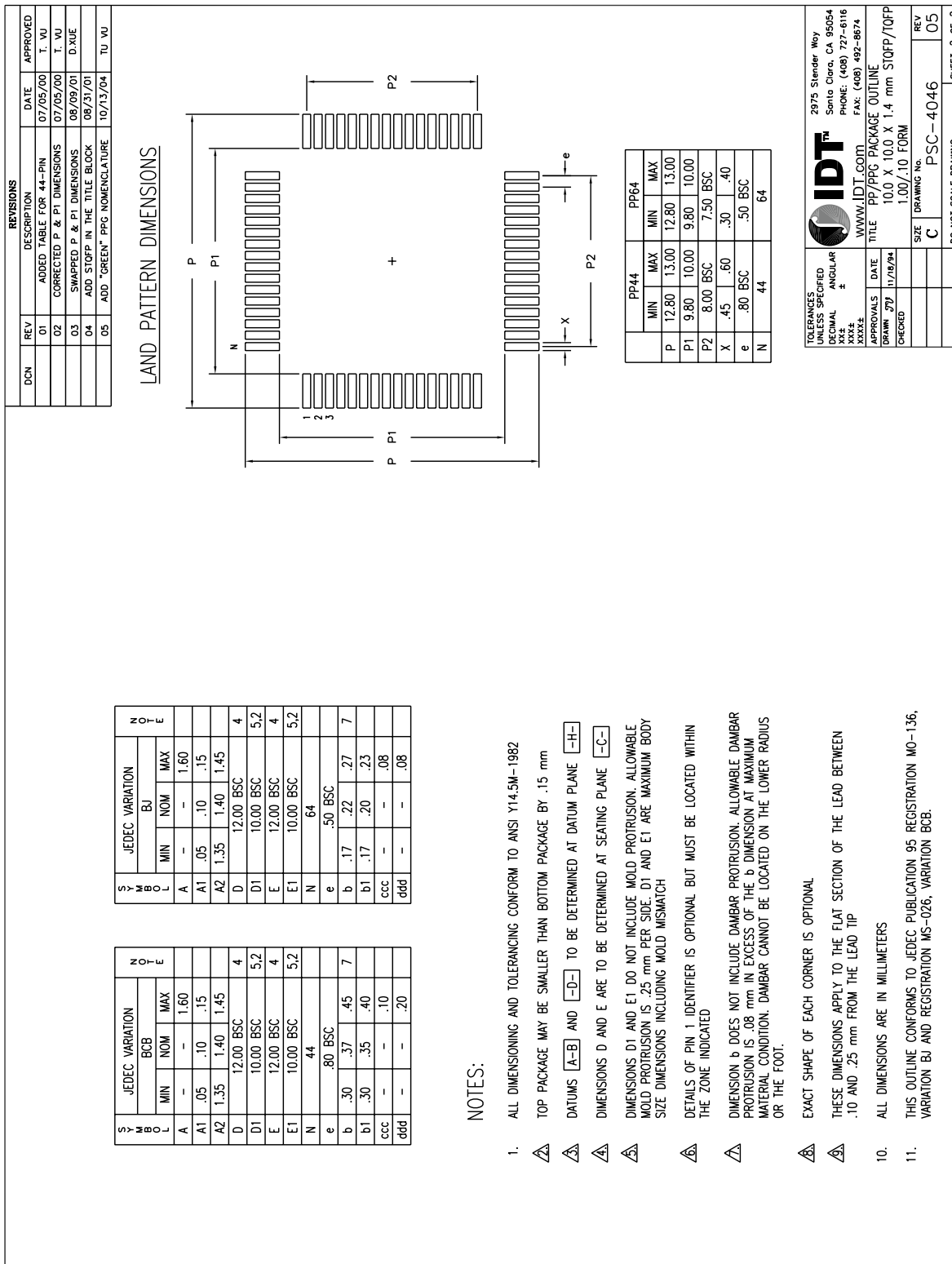

Figure 24. 64-Pin PP Package Dimensions (b) (in Millimeters)

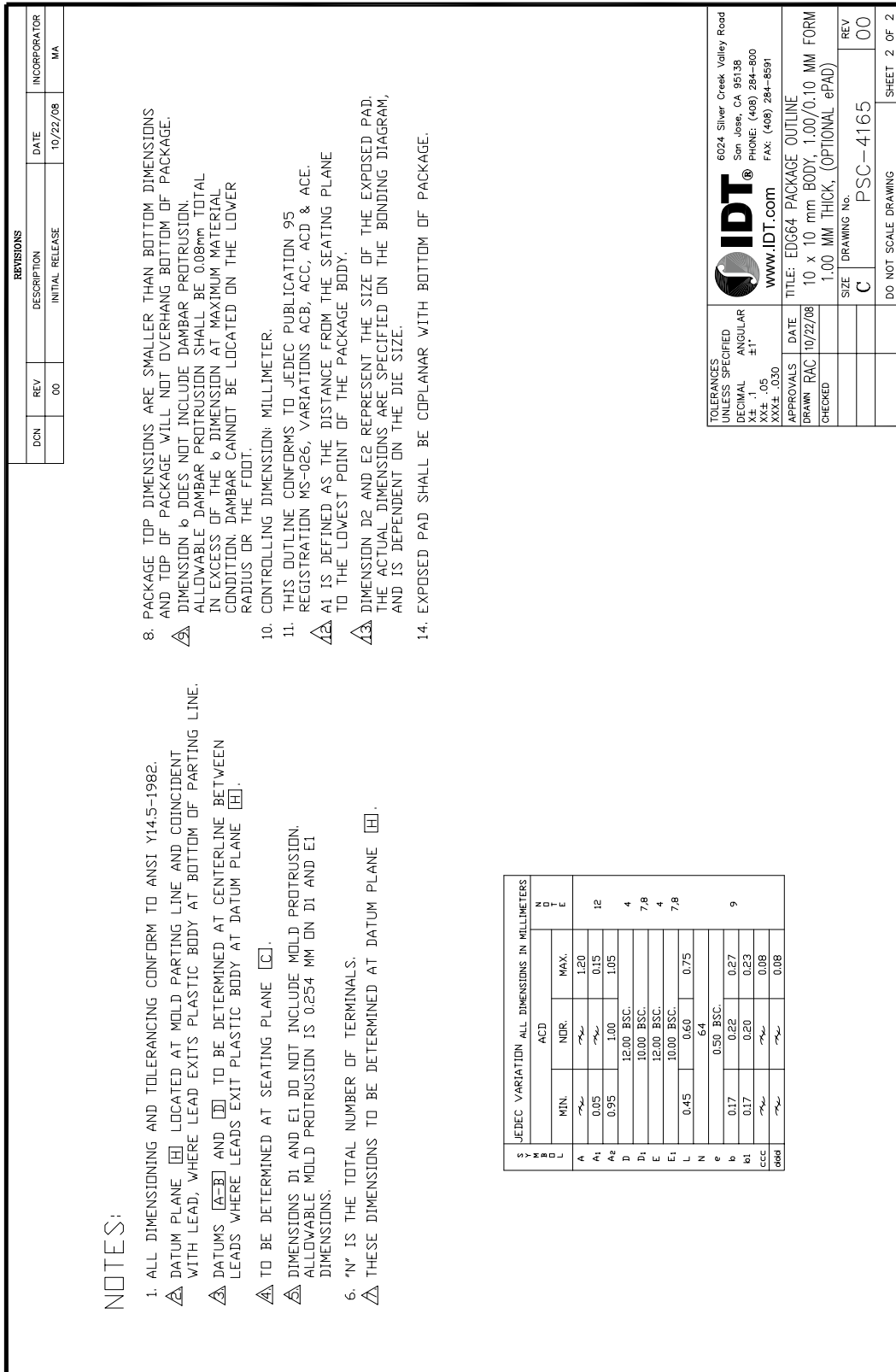

Figure 26. 64-Pin EDG Package Dimensions (b) (in Millimeters)

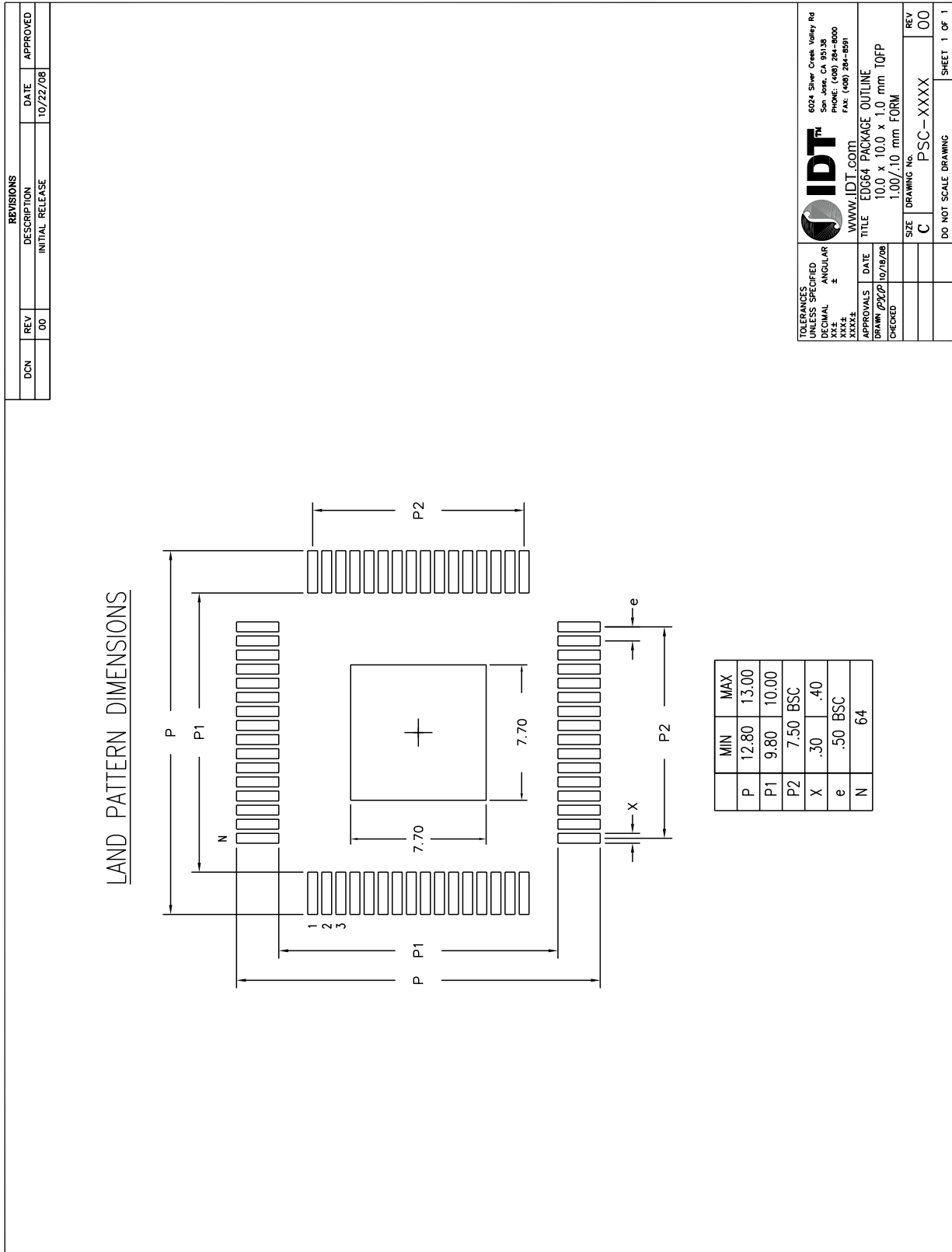
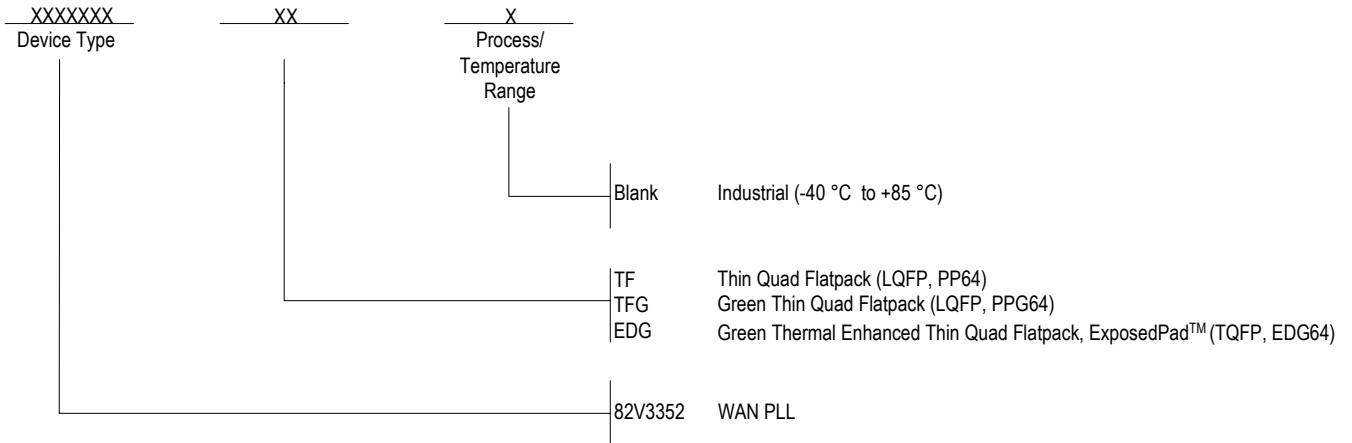

Figure 27. EDG64 Recommended Land Pattern with Exposed Pad (in Millimeters)

ORDERING INFORMATION



DATASHEET DOCUMENT HISTORY

11/18/2008 pgs. 103, 104, 109, 120, 121, 122, 123, 124, 125

12/03/2008 pg. 125

03/23/2009 pg. 11



CORPORATE HEADQUARTERS
 6024 Silver Creek Valley Road
 San Jose, CA 95138
 www.idt.com

for SALES:
 1-800-345-7015 or 408-284-8200
 fax: 408-284-2775

for Tech Support:
 408-360-1552
 email:telecomhelp@idt.com