

The MPC9850 is a PLL based clock generator specifically designed for Freescale Microprocessor and Microcontroller applications including the PowerQUICC III. This device generates a microprocessor input clock plus the 500 MHz Rapid I/O clock. The microprocessor clock is selectable in output frequency to any of the commonly used microprocessor input and bus frequencies. The Rapid I/O outputs are LVDS compatible. The device offers eight low skew clock outputs organized into two output banks, each configurable to support different clock frequencies. The extended temperature range of the MPC9850 supports telecommunication and networking requirements.

Features

- 8 LVCMOS outputs for processor and other circuitry
- 2 differential LVDS outputs for Rapid I/O interface
- Crystal oscillator or external reference input
- 25 or 33 MHz Input reference frequency
- Selectable output frequencies include = 200, 166, 133, 125, 111, 100, 83, 66, 50, 33 or 16 MHz
- Buffered reference clock output
- Rapid I/O (LVDS) Output = 500, 250 or 125 MHz
- Low cycle-to-cycle and period jitter
- 100-lead PBGA package, Pb-free
- 3.3V supply with 3.3V or 2.5V output LVCMOS drive
- Supports computing, networking, telecommunications applications
- Ambient temperature range -40°C to $+85^{\circ}\text{C}$

Functional Description

The MPC9850 uses either a 25 or 33 MHz reference frequency to generate 8 LVCMOS output clocks, of which, the frequency is selectable from 16 MHz to 200 MHz. The reference is applied to the input of a PLL and multiplied to 2 GHz. Output dividers, divide this frequency by 10, 12, 15, 16, 18, 20, 24, 30, 40, 60 or 120 to produce output frequencies of 200, 166, 133, 125, 111, 100, 83, 66, 50, 33 or 16 MHz. The single-ended LVCMOS outputs are divided into two banks of 4 low skew outputs each, for use in driving a microprocessor or microcontroller clock input as well as other system components. The 2 GHz PLL output frequency is also divided to produce a 125, 250 or 500 MHz clock output for Rapid I/O applications such as found on the PowerQUICC III communications processor. The input reference, either crystal or external input is also buffered to a separate output that may be used as the clock source for a Gigabit Ethernet PHY if desired.

The reference clock may be provided by either an external clock input of 25 MHz or 33 MHz. An internal oscillator requiring a 25 MHz crystal for frequency control may also be used. The external clock source may be applied to either of two clock inputs and selected via the CLK_SEL control input. Both single ended LVCMOS and differential LVPECL inputs are available. The crystal oscillator or external clock input is selected via the input pin of REF_SEL. Other than the crystal, no external components are required for crystal oscillator operation. The REF_33MHz configuration pins is used to select between a 33 and 25 MHz input frequency.

The MPC9850 is packaged in a 100 lead MAPBGA package to optimize both performance and board density.

MPC9850

**MICROPROCESSOR
CLOCK GENERATOR**



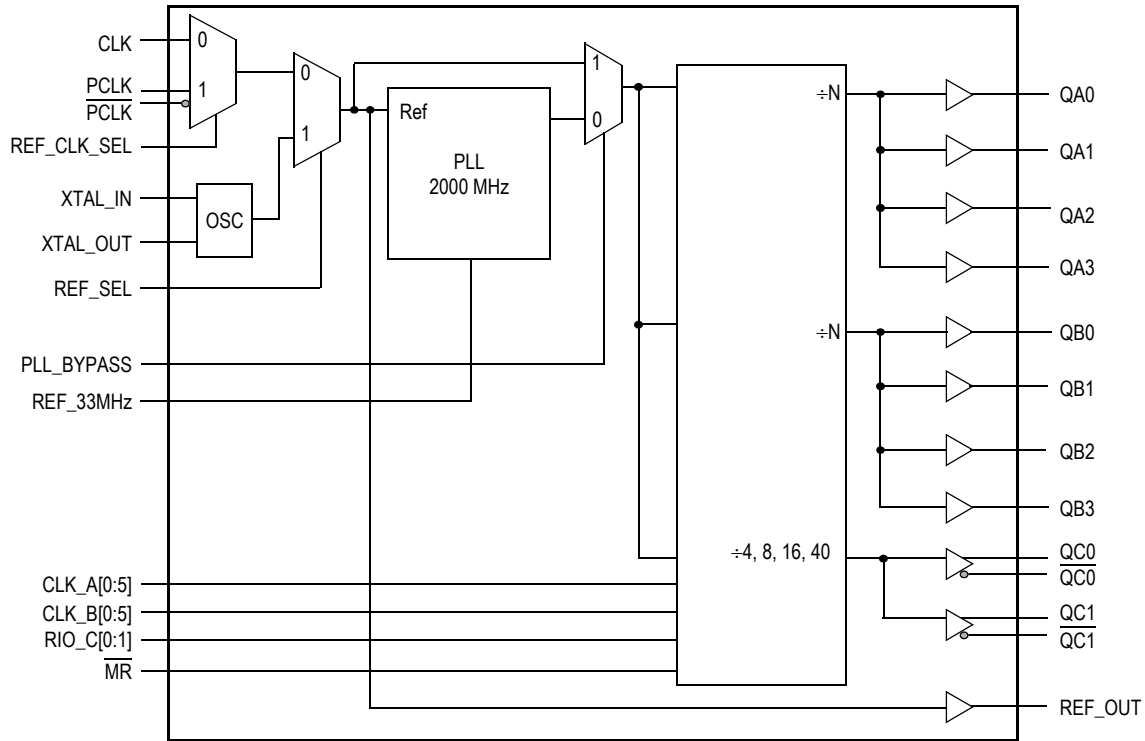

Figure 1. MPC9850 Logic Diagram

Table 1. Pin Configurations

Pin	I/O	Type	Function	Supply	Active/State
CLK	Input	LVC MOS	PLL Reference Clock Input (pull-down)	V _{DD}	
PCLK, PCLK	Input	LVPECL	PLL Reference Clock Input (PCLK - pull-down, PCLK - pull-up and pull-down)	V _{DD}	
QA0, QA1, QA2, QA3	Output	LVC MOS	Bank A Outputs	V _{DDOA}	
QB0, QB1, QB2, QB3	Output	LVC MOS	Bank B Outputs	V _{DDOB}	
QC0, QC1, QC0, QC1	Output	LVDS	Bank C Outputs	V _{DDOC}	
REF_OUT	Output	LVC MOS	Reference Output (25 MHz or 33 MHz)	V _{DD}	
XTAL_IN	Input	LVC MOS	Crystal Oscillator Input Pin	V _{DD}	
XTAL_OUT	Output	LVC MOS	Crystal Oscillator Output Pin	V _{DD}	
REF_CLK_SEL	Input	LVC MOS	Select between CLK and PCLK Input (pull-down)	V _{DD}	High
REF_SEL	Input	LVC MOS	Select between External Input and Crystal Oscillator Input (pull-down)	V _{DD}	High
REF_33MHz	Input	LVC MOS	Selects 33 MHz Input (pull-down)	V _{DD}	High
MR	Input	LVC MOS	Master Reset (pull-up)	V _{DD}	Low
PLL_BYPASS	Input	LVC MOS	Select PLL or static test mode (pull-down)	V _{DD}	High
CLK_A[0:5] ⁽¹⁾	Input	LVC MOS	Configures Bank A clock output frequency (pull-up)	V _{DD}	High
CLK_B[0:5] ⁽²⁾	Input	LVC MOS	Configures Bank B clock output frequency (pull-up)	V _{DD}	High
RIO_C [0:1]	Input	LVC MOS	Configures Bank C clock output frequency (pull-down)	V _{DD}	
V _{DD}			3.3 V Supply		
V _{DDA}			Analog Supply		
V _{DDOA}			Supply for Output Bank A		
V _{DDOB}			Supply for Output Bank B		
V _{DDOC}			Supply for Output Bank C		
GND			Ground		

1. PowerPC bit ordering (bit 0 = msb, bit 5 = lsb)

2. PowerPC bit ordering (bit 0 = msb, bit 5 = lsb)

PowerPC bit ordering (bit 0 = msb, bit 1 = lsb)

Table 2. Function Table

Control	Default	0	1
REF_CLK_SEL	0	CLK	PCLK
REF_SEL	0	CLK or PCLK	XTAL
PLL_BYPASS	0	Normal	Bypass
REF_33MHz	0	Selects 25 MHz Reference	Selects 33 MHz Reference
$\overline{\text{MR}}$	1	Reset	Normal

CLK_A, CLK_B, and RIO_C control output frequencies. See [Table 3](#) and [Table 4](#) for specific device configuration

Table 3. Output Configurations (Banks A & B)

CLK_x[0:5] ⁽¹⁾	CLK_x[0] (msb)	CLK_x[1]	CLK_x[2]	CLK_x[3]	CLK_x[4]	CLK_x[5] (lsb)	N	Frequency (MHz)
111111	1	1	1	1	1	1	126	15.87
111100	1	1	1	1	0	0	120	16.67
101000	1	0	1	0	0	0	80	25.00
011110	0	1	1	1	1	0	60	33.33
010100	0	1	0	1	0	0	40	50.00
001111	0	0	1	1	1	1	30	66.67
001100	0	0	1	1	0	0	24	83.33
001010	0	0	1	0	1	0	20	100.00
001001	0	0	1	0	0	1	18	111.11
001000	0	0	1	0	0	0	16	125.00
000111	0	0	0	1	1	1	15	133.33
000110	0	0	0	1	1	0	12	166.67
000101	0	0	0	1	0	1	10	200.00
000100	0	0	0	1	0	0	8 ⁽²⁾	250

1. PowerPC bit ordering (bit 0 = msb, bit 5 = lsb)

2. Minimum value for N

Table 4. Output Configurations (Bank C)

RIO_C[0:1]	Frequency (MHz)
00	50 (test output)
01	125
10	250
11	500

OPERATION INFORMATION

Output Frequency Configuration

The MPC9850 was designed to provide the commonly used frequencies in PowerQUICC, PowerPC and other microprocessor systems. [Table 3](#) lists the configuration values that will generate those common frequencies. The MPC9850 can generate numerous other frequencies that may be useful in specific applications. The output frequency (f_{out}) of either Bank A or Bank B may be calculated by the following equation.

$$f_{out} = 2000 / N$$

where f_{out} is in MHz and $N = 2 * CLK_x[0:5]$

This calculation is valid for all values of N from 8 to 126. Note that N = 15 is a modified case of the configuration inputs

CLK_x[0:5]. To achieve N = 15 CLK_x[0:5] is configured to 00111 or 7.

Crystal Input Operation

TBD

Power-Up and MR Operation

[Figure 2](#) defines the t_{reset_rel} and the minimum pulse length for MR pin. The MR release time is based upon the power supply being stable and within V_{DD} specifications. See [Table 11](#) for actual parameter values. The MPC9850 may be configured after release of reset and the outputs will be stable for use after lock indication is obtained.

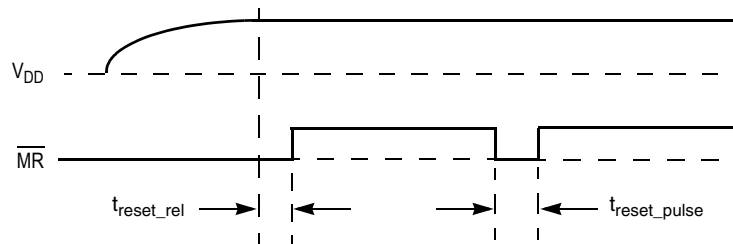

Figure 2. MR Operation

Power Supply Bypassing

The MPC9850 is a mixed analog/digital product. The architecture of the MPC9850 supports low noise signal operation at high frequencies. In order to maintain its superior signal quality, all V_{DD} pins should be bypassed by high-frequency ceramic capacitors connected to GND. If the spectral frequencies of the internally generated switching noise on the supply pins cross the series resonant point of an individual bypass capacitor, its overall impedance begins to look inductive and thus increases with increasing frequency. The parallel capacitor combination shown ensures that a low impedance path to ground exists for frequencies well above the noise bandwidth.

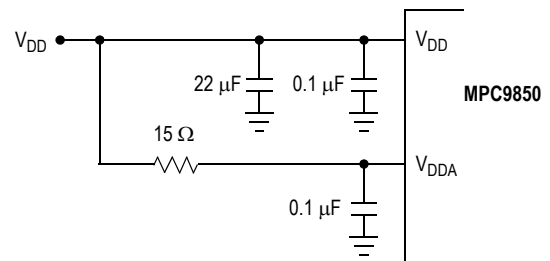

Figure 3. V_{CC} Power Supply Bypass

Table 5. Absolute Maximum Ratings⁽¹⁾

Symbol	Characteristics	Min	Max	Unit	Condition
V _{DD}	Supply Voltage (core)	-0.3	3.8	V	
V _{DDA}	Supply Voltage (Analog Supply Voltage)	-0.3	V _{DD}	V	
V _{DDOx}	Supply Voltage (LVCMOS output for Bank A or B)	-0.3	V _{DD}	V	
V _{IN}	DC Input Voltage	-0.3	V _{DD} +0.3	V	
V _{OUT}	DC Output Voltage ⁽²⁾	-0.3	V _{DDx} +0.3	V	
I _{IN}	DC Input Current		±20	mA	
I _{OUT}	DC Output Current		±50	mA	
T _S	Storage Temperature	-65	125	°C	

1. Absolute maximum continuous ratings are those maximum values beyond which damage to the device may occur. Exposure to these conditions or conditions beyond those indicated may adversely affect device reliability. Functional operation at absolute-maximum-rated conditions is not implied.
2. V_{DDx} references power supply pin associated with specific output pin.

Table 6. General Specifications

Symbol	Characteristics	Min	Typ	Max	Unit	Condition
V _{TT}	Output Termination Voltage		V _{DD} ÷ 2		V	
HBM	ESD Protection (Human Body Model)	2000			V	
CDM	ESD Protection (Charged Device Model)	500			V	
LU	Latch-Up Immunity	100			mA	
C _{IN}	Input Capacitance		4		pF	Inputs
C _{PD}	Power Dissipation Capacitance		10		pF	Per Output
θ _{JA}	Thermal Resistance (junction-to-ambient)		54.5		°C/W	Air flow = 0
T _A	Ambient Temperature	-40		85	°C	

Table 7. DC Characteristics (T_A = -40°C to 85°C)

Symbol	Characteristics	Min	Typ	Max	Unit	Condition
Supply Current for V _{DD} = 3.3 V ± 5%, V _{DDOA} = 3.3 V ± 5 and V _{DDOB} = 3.3 V ± 5%						
I _{DD} + I _{DDA}	Maximum Quiescent Supply Current (Core)			200	mA	V _{DD} + V _{DDA} pins
I _{DDA}	Maximum Quiescent Supply Current (Analog Supply)			15	mA	V _{DDIN} pins
I _{DDOA} , I _{DDOB}	Maximum Bank A and B Supply Current			175	mA	V _{DDOA} and V _{DDOB} pins
Supply Current for V _{DD} = 3.3 V ± 5%, V _{DDOA} = 2.5 V ± 5% and V _{DDOB} = 2.5 V ± 5%						
I _{DD} + I _{DDA}	Maximum Quiescent Supply Current (Core)			200	mA	V _{DD} + V _{DDA} pins
I _{DDA}	Maximum Quiescent Supply Current (Analog Supply)			15	mA	V _{DDIN} pins
I _{DDOA} , I _{DDOB}	Maximum Bank A and B Supply Current			100	mA	V _{DDOA} and V _{DDOB} pins

Table 8. LVDS DC Characteristics ($T_A = -40^\circ\text{C}$ to 85°C)

Symbol	Characteristics	Min	Typ	Max	Unit	Condition
Differential LVDS Clock Outputs (QC0, $\overline{\text{QC0}}$ and QC1, $\overline{\text{QC1}}$) for $V_{DD} = 3.3\text{ V} \pm 5\%$						
V_{PP}	Output Differential Voltage ⁽¹⁾ (peak-to-peak) (LVDS)	100		400	mV	
V_{OS}	Output Offset Voltage (LVDS)	1050		1600	mV	

1. V_{PP} is the minimum differential input voltage swing required to maintain AC characteristics including t_{PD} and device-to-device skew.

Table 9. LVPECL DC Characteristics ($T_A = -40^\circ\text{C}$ to 85°C)⁽¹⁾

Symbol	Characteristics	Min	Typ	Max	Unit	Condition
Differential LVPECL Clock Inputs (CLK1, $\overline{\text{CLK1}}$) for $V_{DD} = 3.3\text{ V} \pm 0.5\%$						
V_{PP}	Differential Voltage ⁽²⁾ (peak-to-peak) (LVPECL)	250			mV	
V_{CMR}	Differential Input Crosspoint Voltage ⁽³⁾ (LVPECL)	1.0		$V_{DD} - 0.6$	V	

1. AC characteristics are design targets and pending characterization.

2. V_{PP} is the minimum differential input voltage swing required to maintain AC characteristics including t_{PD} and device-to-device skew.

3. V_{CMR} (AC) is the crosspoint of the differential input signal. Normal AC operation is obtained when the crosspoint is within the V_{CMR} (AC) range and the input swing lies within the V_{PP} (AC) specification. Violation of V_{CMR} (AC) or V_{PP} (AC) impacts the device propagation delay, device and part-to-part skew.

Table 10. LVCMOS I/O DC Characteristics ($T_A = -40^\circ\text{C}$ to 85°C)

Symbol	Characteristics	Min	Typ	Max	Unit	Condition
LVCMOS for $V_{DD} = 3.3\text{ V} \pm 5\%$						
V_{IH}	Input High Voltage	2.0		$V_{DD} + 0.3$	V	LVCMOS
V_{IL}	Input Low Voltage			0.8	V	LVCMOS
I_{IN}	Input Current ⁽¹⁾			± 200	μA	$V_{IN} = V_{DDL}$ or GND
LVCMOS for $V_{DD} = 3.3\text{ V} \pm 5\%$, $V_{DDOA} = 3.3\text{ V} \pm 5\%$ and $V_{DDOB} = 3.3\text{ V} \pm 5\%$						
V_{OH}	Output High Voltage	2.4			V	$I_{OH} = -24\text{ mA}$
V_{OL}	Output Low Voltage			0.5	V	$I_{OL} = 24\text{ mA}$
Z_{OUT}	Output Impedance		14 – 17		Ω	
LVCMOS for $V_{DD} = 3.3\text{ V} \pm 5\%$, $V_{DDOA} = 2.5\text{ V} \pm 5\%$ and $V_{DDOB} = 2.5\text{ V} \pm 5\%$						
V_{OH}	Output High Voltage	1.9			V	$I_{OH} = -15\text{ mA}$
V_{OL}	Output Low Voltage			0.4	V	$I_{OL} = 15\text{ mA}$
Z_{OUT}	Output Impedance		18 – 22		Ω	

1. Inputs have pull-down resistors affecting the input current.

Table 11. AC Characteristics ($V_{DD} = 3.3\text{ V} \pm 5\%$, $V_{DDOA} = 3.3\text{ V} \pm 5\%$, $V_{DDOB} = 3.3\text{ V} \pm 5\%$, $T_A = -40^\circ\text{C}$ to $+85^\circ\text{C}$)^{(1) (2)}

Symbol	Characteristics	Min	Typ	Max	Unit	Condition
Input and Output Timing Specification						
f_{ref}	Input Reference Frequency (25 MHz input) Input Reference Frequency (33 MHz input) XTAL Input Input Reference Frequency in PLL Bypass Mode ⁽³⁾		25 33 25		MHz MHz MHz MHz	PLL bypass
f_{VCO}	VCO Frequency Range ⁽⁴⁾		2000		MHz	
f_{MCX}	Output Frequency Bank A output Bank B output Bank C output	15.87 15.87 50		200 200 500	MHz MHz MHz	PLL locked
f_{refPW}	Reference Input Pulse Width	2			ns	
f_{refCcc}	Input Frequency Accuracy			100	ppm	
t_r, t_f	Output Rise/Fall Time	150		500	ps	20% to 80%
DC	Output Duty Cycle	43 47	50 50	57 53	%	Bank A and B Bank C
PLL Specifications						
t_{LOCK}	Maximum PLL Lock Time			10	ms	
t_{reset_ref}	MR Hold Time on Power Up	10			ns	
t_{reset_pulse}	MR Hold Time	10			ns	
Skew and Jitter Specifications						
$t_{sk(O)}$	Output-to-Output Skew (within a bank)			50	ps	
$t_{sk(O)}$	Output-to-Output Skew (across banks A and B)			400	ps	$V_{DDOA} = 3.3\text{ V}$ $V_{DDOB} = 3.3\text{ V}$
$t_{JIT(CC)}$	Cycle-to-Cycle Jitter			200 150	ps ps	Bank A and B Bank C
$t_{JIT(PER)}$	Period Jitter			200	ps	Bank A and C
$t_{JIT(\emptyset)}$	I/O Phase Jitter RMS (1 σ)			50	ps	Bank A and C

1. AC characteristics are design targets and pending characterization.
2. AC characteristics apply for parallel output termination of 50Ω to V_{TT} .
3. In bypass mode, the MPC9850 divides the input reference clock.
4. The input reference frequency must match the VCO lock range divided by the total feedback divider ratio: $f_{ref} = (f_{VCO} \div M) \cdot N$.

**Figure 4. MPC9850 AC Test Reference (LVDS Outputs)****Figure 5. MPC9850 AC Test Reference (LVCMOS Outputs)**

Table 12. MPC9850 Pin Diagram (Top View)

	1	2	3	4	5	6	7	8	9	10
A	V _{DDOA}	V _{DDOA}	CLKA[1]	CLKA[3]	CLKA[5]	V _{DD}	QA1	QA2	V _{DDOA}	V _{DDOA}
B	V _{DDOA}	V _{DDOA}	CLKA[0]	CLKA[2]	CLKA[4]	QA0	V _{DDOA}	QA3	V _{DDOA}	V _{DDOA}
C	RSVD	RSVD	V _{DD}	V _{DD}	V _{DD}	V _{DD}	V _{DD}	V _{DD}	V _{DD}	REF_OUT
D	V _{DDA}	V _{DDA}	V _{DD}	GND	GND	GND	GND	V _{DD}	$\overline{QC0}$	QC0
E	REF_SEL	CLK	V _{DD}	GND	GND	GND	GND	V _{DD}	V _{DDOC}	GND
F	PCLK	\overline{PCLK}	V _{DD}	GND	GND	GND	GND	V _{DD}	$\overline{QC1}$	QC1
G	REF_CLK_SEL	REF_33MHz	V _{DD}	GND	GND	GND	GND	V _{DD}	PLL_BYPASS	\overline{MR}
H	XTAL_IN	XTAL_OUT	V _{DD}	V _{DD}	V _{DD}	V _{DD}	V _{DD}	V _{DD}	RIO_C[1]	RIO_C[0]
J	V _{DDOB}	V _{DDOB}	CLKB[0]	CLKB[2]	CLKB[4]	QB0	V _{DDOB}	QB3	V _{DDOB}	V _{DDOB}
K	V _{DDOB}	V _{DDOB}	CLKB[1]	CLKB[3]	CLKB[5]	V _{DD}	QB1	QB2	V _{DDOB}	V _{DDOB}

Table 13. MPC9850 Pin List

Signal	100 Pin MABGA	Signal	100 Pin MABGA	Signal	100 Pin MABGA	Signal	100 Pin MABGA	Signal	100 Pin MABGA
V _{DDOA}	A1	RSVD ⁽¹⁾	C1	REF_SEL	E1	REF_CLK_SEL	G1	V _{DDOB}	J1
V _{DDOA}	A2	RSVD ⁽¹⁾	C2	CLK	E2	REF_33MHz	G2	V _{DDOB}	J2
CLKA[1]	A3	V _{DD}	C3	V _{DD}	E3	V _{DD}	G3	CLKB[0]	J3
CLKA[3]	A4	V _{DD}	C4	GND	E4	GND	G4	CLKB[2]	J4
CLKA[5]	A5	V _{DD}	C5	GND	E5	GND	G5	CLKB[4]	J5
V _{DD}	A6	V _{DD}	C6	GND	E6	GND	G6	QB0	J6
QA1	A7	V _{DD}	C7	GND	E7	GND	G7	V _{DDOB}	J7
QA2	A8	V _{DD}	C8	V _{DD}	E8	V _{DD}	G8	QB3	J8
V _{DDOA}	A9	V _{DD}	C9	V _{DDOC}	E9	PLL_BYPASS	G9	V _{DDOB}	J9
V _{DDOA}	A10	REF_OUT	C10	GND	E10	\overline{MR}	G10	V _{DDOB}	J10
V _{DDOA}	B1	V _{DDA}	D1	PCLK	F1	XTAL_IN	H1	V _{DDOB}	K1
V _{DDOA}	B2	V _{DDA}	D2	\overline{PCLK}	F2	XTAL_OUT	H2	V _{DDOB}	K2
CLKA[0]	B3	V _{DD}	D3	V _{DD}	F3	V _{DD}	H3	CLKB[1]	K3
CLKA[2]	B4	GND	D4	GND	F4	V _{DD}	H4	CLKB[3]	K4
CLKA[4]	B5	GND	D5	GND	F5	V _{DD}	H5	CLKB[5]	K5
QA0	B6	GND	D6	GND	F6	V _{DD}	H6	V _{DD}	K6
V _{DDOA}	B7	GND	D7	GND	F7	V _{DD}	H7	QB1	K7
QA3	B8	V _{DD}	D8	V _{DD}	F8	V _{DD}	H8	QB2	K8
V _{DDOA}	B9	$\overline{QC0}$	D9	$\overline{QC1}$	F9	RIO_C[1]	H9	V _{DDOB}	K9
V _{DDOA}	B10	QC0	D10	QC1	F10	RIO_C[0]	H10	V _{DDOB}	K10

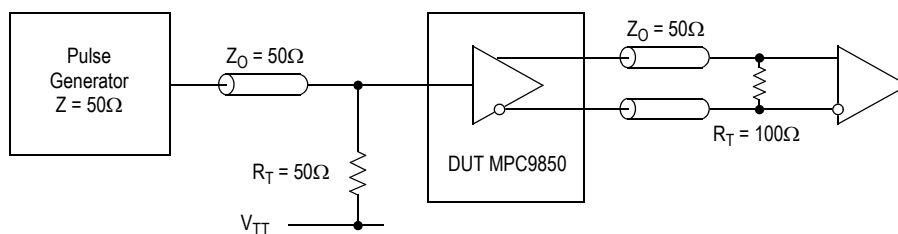
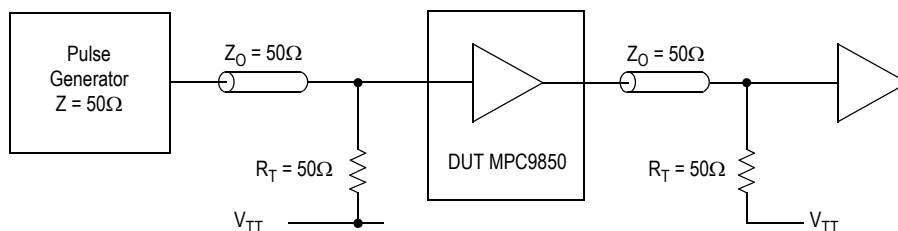
1. RSVD pins must be left open.

PACKAGE DIMENSIONS

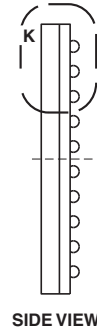
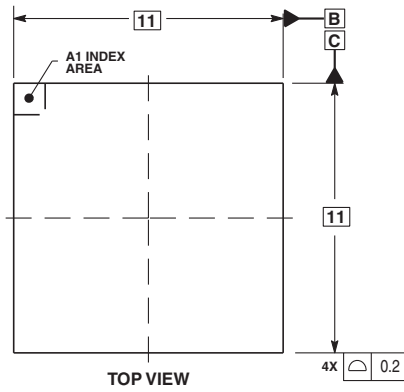

- NOTES:
1. ALL DIMENSIONS ARE IN MILLIMETERS.
 2. DIMENSIONING AND TOLERANCING PER ASME Y14.5M, 1994.
 3. MAXIMUM SOLDER BALL DIAMETER MEASURED PARALLEL TO DATUM A.
 4. DATUM A, SEATING PLANE, IS DEFINED BY THE SPHERICAL CROWNS OF THE SOLDER BALLS. PARALLELISM MEASUREMENT SHALL EXCLUDE ANY EFFECT OF MARK ON TOP SURFACE OF PACKAGING.

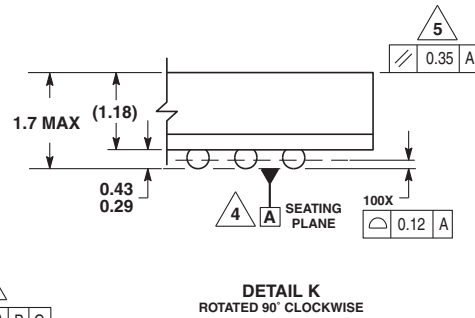
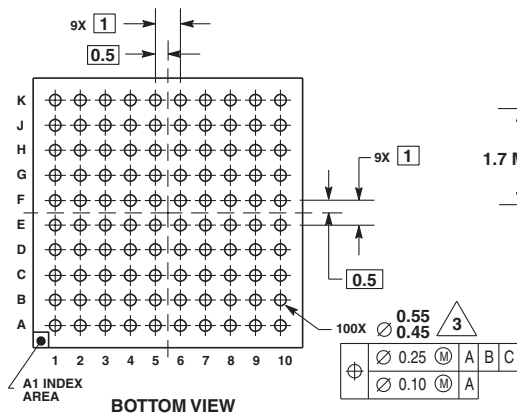

**VA SUFFIX
VM SUFFIX (PB-FREE)
100 MAPBGA PACKAGE
CASE 1462-01
ISSUE O**

NOTES

Revision History Sheet

Rev	Table	Page	Description of Change	Date
6		1	Product Discontinuance Notice – Last Time Buy Expires on (1/31/2014)	2/6/2013

We've Got Your Timing Solution



6024 Silver Creek Valley Road
San Jose, California 95138

Sales
800-345-7015 (inside USA)
+408-284-8200 (outside USA)
Fax: 408-284-2775
www.IDT.com/go/contactIDT

Technical Support
netcom@idt.com
+480-763-2056

DISCLAIMER Integrated Device Technology, Inc. (IDT) and its subsidiaries reserve the right to modify the products and/or specifications described herein at any time and at IDT's sole discretion. All information in this document, including descriptions of product features and performance, is subject to change without notice. Performance specifications and the operating parameters of the described products are determined in the independent state and are not guaranteed to perform the same way when installed in customer products. The information contained herein is provided without representation or warranty of any kind, whether express or implied, including, but not limited to, the suitability of IDT's products for any particular purpose, an implied warranty of merchantability, or non-infringement of the intellectual property rights of others. This document is presented only as a guide and does not convey any license under intellectual property rights of IDT or any third parties.

IDT's products are not intended for use in applications involving extreme environmental conditions or in life support systems or similar devices where the failure or malfunction of an IDT product can be reasonably expected to significantly affect the health or safety of users. Anyone using an IDT product in such a manner does so at their own risk, absent an express, written agreement by IDT.

Integrated Device Technology, IDT and the IDT logo are registered trademarks of IDT. Other trademarks and service marks used herein, including protected names, logos and designs, are the property of IDT or their respective third party owners.

Copyright 2013. All rights reserved.