

LOW COST 54 MHZ 3.3 VOLT VCXO

MK3754

Description

The MK3754D and MK3754B are drop-in replacements for the MK3754S device. Compared to these earlier devices the MK3754D and MK3754B offer a wider operating frequency range and improved power supply noise rejection.

The MK3754 is ICS' lowest cost, low jitter, high performance 3.3 Volt VCXO and PLL clock synthesizer designed to replace expensive 54 MHz VCXOs. The on-chip Voltage Controlled Crystal Oscillator accepts a 0 to 3.3 V input voltage to vary the output clocks by ± 100 ppm. Using ICS' patented VCXO and analog/digital Phase-Locked Loop (PLL) techniques, the device uses an inexpensive external 13.5 MHz pullable crystal input to produce a 54 MHz output clock.

The MK3754D exhibits a moderate VCXO gain of 120 ppm/V typical, when used with a high quality external pullable quartz crystal. The MK3754B offers a higher VCXO gain of 150 ppm/V. The higher intrinsic VCXO gain of the MK3754B may help compensate for the reduced pullability of a low quality crystal used in some applications. However, higher VCXO gain may also increase clock output phase noise.

The frequency of the on-chip VCXO is adjusted by an external control voltage input into pin VIN. Because VIN is a high impedance input, it can be driven directly from an PWM RC integrator circuit. Frequency output increases with VIN voltage input. The usable range of VIN is 0 to 3 V.

Features

- MK3754D and MK3754B are drop-in upgrades to the earlier MK3754S device
- Packaged in 8-pin SOIC
- Available in Pb (lead) free package
- Operating voltage of 3.3 V
- Uses an inexpensive 13.500 MHz external crystal
- On-chip VCXO (patented) with pull range of 200 ppm (minimum)
- VCXO turning voltage of 0 to 3.3V
- 12 mA output drive capability at TTL levels
- Advanced, low power, sub-micron CMOS process

MK3754D is Recommended for New Designs.

Block Diagram

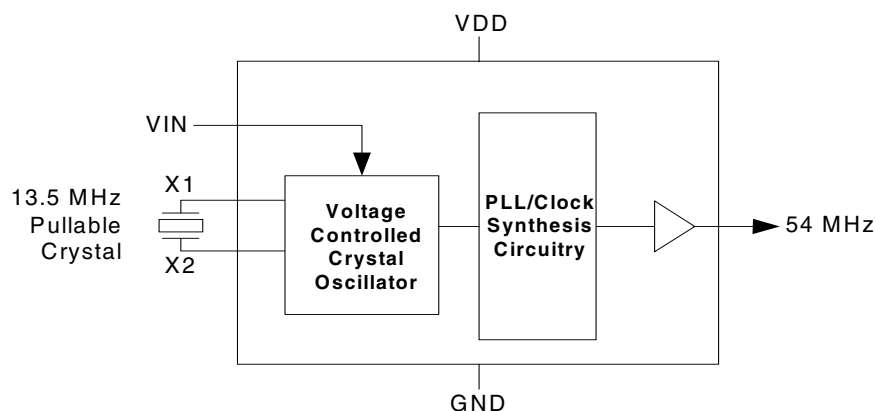

Pin Assignment

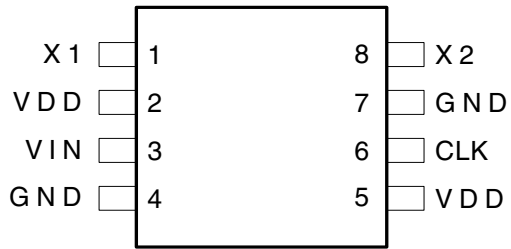

MK3754S
MK3754B
MK3754D

8 Pin (150 mil) SOIC

Pin Descriptions

Pin Number	Pin Name	Pin Type	Pin Description
1	X1	Input	Crystal connection. Connect to the external pullable crystal.
2	VDD	Power	Connect to +3.3 V (0.01uf decoupling capacitor recommended).
3	VIN	Input	Voltage input to VCXO -- 0 to 3.3 V analog input which controls the oscillation frequency of the VCXO.
4	GND	Power	Connect to ground.
5	VDD	Power	Connect to +3.3 V (0.01uf decoupling capacitor recommended).
6	CLK	Output	54 MHz clock output.
7	GND	Power	Connect to ground.
8	X2	Input	Crystal connection. Connect to the external pullable crystal.

External Component Selection

The MK3754 requires a minimum number of external components for proper operation.

Decoupling Capacitor

A decoupling capacitor of 0.01 μF must be connected between VDD (pin 2) and GND (pin 4), as close to these pins as possible. For optimum device performance, the decoupling capacitor should be mounted on the component side of the PCB. Avoid the use of vias in the decoupling circuit.

Series Termination Resistor

When the PCB trace between the clock output (CLK, pin 5) and the load is over 1 inch, series termination should be used. To series terminate a 50 Ω trace (a commonly used trace impedance) place a 33 Ω resistor in series with the clock line, as close to the clock output pin as possible. The nominal impedance of the clock output is 20 Ω .

Quartz Crystal

The MK3754 VCXO function consists of the external crystal and the integrated VCXO oscillator circuit. To assure the best system performance (frequency pull range) and reliability, a crystal device with the recommended parameters (shown below) must be used, and the layout guidelines discussed in the following section shown must be followed.

The frequency of oscillation of a quartz crystal is determined by its “cut” and by the load capacitors connected to it. The MK3754 incorporates on-chip variable load capacitors that “pull” (change) the frequency of the crystal. The crystal specified for use with the MK3754 is designed to have zero frequency error when the total of on-chip + stray capacitance is 14 pF.

Recommended Crystal Parameters:

Initial Accuracy at 25°C	± 20 ppm
Temperature Stability	± 30 ppm
Aging	± 20 ppm
Load Capacitance	14 pf
Shunt Capacitance, C0	7 pF Max
C0/C1 Ratio	250 Max
Equivalent Series Resistance	35 Ω Max

The external crystal must be connected as close to the chip

as possible and should be on the same side of the PCB as the MK3754. There should be no via's between the crystal pins and the X1 and X2 device pins. There should be no signal traces underneath or close to the crystal.

Crystal Tuning Load Capacitors

The crystal traces should include pads for small fixed capacitors, one between X1 and ground, and another between X2 and ground. Stuffing of these capacitors on the PCB is optional. The need for these capacitors is determined at system prototype evaluation, and is influenced by the particular crystal used (manufacture and frequency) and by PCB layout. The typical required capacitor value is 1 to 4 pF.

The procedure for determining the value of these capacitors can be found in application note MAN05.

Absolute Maximum Ratings

Stresses above the ratings listed below can cause permanent damage to the MK3754. These ratings, which are standard values for ICS commercially rated parts, are stress ratings only. Functional operation of the device at these or any other conditions above those indicated in the operational sections of the specifications is not implied. Exposure to absolute maximum rating conditions for extended periods can affect product reliability. Electrical parameters are guaranteed only over the recommended operating temperature range.

Item	Rating
Supply Voltage, VDD	7V
All Inputs and Outputs	-0.5V to VDD+0.5V
Ambient Operating Temperature	0 to +70°C
Storage Temperature	-65 to +150°C
Soldering Temperature	260°C

Recommended Operation Conditions

Parameter	Min.	Typ.	Max.	Units
Ambient Operating Temperature	0	–	+70	°C
Power Supply Voltage (measured in respect to GND)	+3.15		+3.45	V
Reference crystal parameters	Refer to page 3			

DC Electrical Characteristics

VDD=3.3 V \pm 5% , Ambient temperature 0 to +70°C, unless stated otherwise

Parameter	Symbol	Conditions	Min.	Typ.	Max.	Units
Operating Voltage	VDD		3.15		3.45	V
Output High Voltage	V _{OH}	I _{OH} = -12 mA	2.4			V
Output Low Voltage	V _{OL}	I _{OL} = 12 mA			0.4	V
Output High Voltage (CMOS Level)	V _{OH}	I _{OH} = -4 mA	VDD-0.4			V
Operating Supply Current	IDD	No load		9		mA
Short Circuit Current	I _{OS}			\pm 50		mA
VIN, VCXO Control Voltage	V _{IA}		0		3.3	V

AC Electrical Characteristics

VDD = 3.3 V \pm 5%, Ambient Temperature 0 to +70° C, unless stated otherwise

Parameter	Symbol	Conditions	Min.	Typ.	Max.	Units
Crystal Pullability						
MK3754D and MK3754B	F _P	0V \leq VIN \leq 3.3 V, Note 1	\pm 115			ppm
MK3754S	F _P	0V \leq VIN \leq 3.3 V, Note 1	\pm 100			ppm
VCXO Gain						
MK3754D		VIN = VDD/2 \pm 1 V, Note 1		120		ppm/V
MK3754B		VIN = VDD/2 \pm 1 V, Note 1		150		ppm/V
MK3754S		VIN = VDD/2 \pm 1 V, Note 1		100		ppm/V
Output Rise Time	t _{OR}	0.8 to 2.0 V, C _L =15 pF			1.5	ns
Output Fall Time	t _{OF}	2.0 to 0.8 V, C _L =15 pF			1.5	ns
Output Clock Duty Cycle	t _D	Measured at 1.4 V, C _L =15 pF	45	50	55	%
Maximum Output Jitter, short term	t _J	C _L =15 pF		100		ps

Note 1: External crystal device must conform with Pullable Crystal Specifications listed on page 3.

Package Outline and Package Dimensions (8-pin SOIC, 150 Mil. Narrow Body)

Package dimensions are kept current with JEDEC Publication No. 95

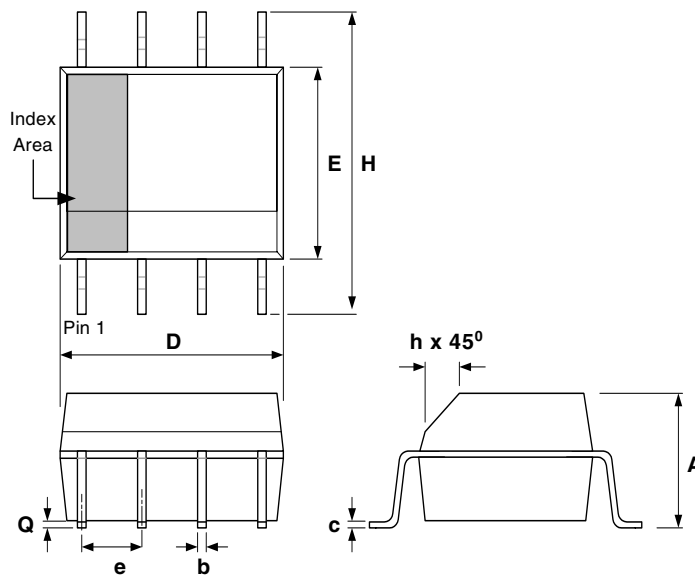

Symbol	Millimeters		Inches*	
	Min	Max	Min	Max
A	1.35	1.75	0.0532	0.0688
A1	1.10	0.25	0.0040	0.0098
B	0.33	0.51	0.013	0.020
C	0.19	0.25	0.0075	0.0098
D	4.80	5.00	.1890	.1968
E	3.80	4.00	0.1497	0.1574
e	1.27 Basic		0.050 Basic	
H	5.80	6.20	0.2284	0.2440
h	0.25	0.50	0.010	0.020
L	0.40	1.27	0.016	0.050
a	0°	8°	0°	8°

*For reference only. Controlling dimensions in mm.

Ordering Information

Part/Order Number (Note 1)	Marking	Shipping Packaging	Package	Temperature
MK3754D	MK3754D	Tubes	8-pin SOIC	0 to +70° C
MK3754DTR	MK3754D	Tape and Reel	8-pin SOIC	0 to +70° C
MK3754DLF	3754DLF	Tubes	8-pin SOIC	0 to +70° C
MK3754DLFTR	3754DLF	Tape and Reel	8-pin SOIC	0 to +70° C
MK3754B	MK3754B	Tubes	8-pin SOIC	0 to +70° C
MK3754BTR	MK3754B	Tape and Reel	8-pin SOIC	0 to +70° C
MK3754BLF	3754BLF	Tubes	8-pin SOIC	0 to +70° C
MK3754BLFTR	3754BLF	Tape and Reel	8-pin SOIC	0 to +70° C
MK3754S	MK3754S	Tubes	8-pin SOIC	0 to +70° C
MK3754STR	MK3754S	Tape and Reel	8-pin SOIC	0 to +70° C
MK3754SLF	3754SLF	Tubes	8-pin SOIC	0 to +70° C
MK3754SLFTR	3754SLF	Tape and Reel	8-pin SOIC	0 to +70° C

Parts that are ordered with a "LF" suffix to the part number are the Pb-Free configuration and are RoHS compliant.

Note 1: MK3754D and MK3754DLF are recommended for new designs. Call factory for information on MK3754S.

While the information presented herein has been checked for both accuracy and reliability, Integrated Circuit Systems (ICS) assumes no responsibility for either its use or for the infringement of any patents or other rights of third parties, which would result from its use. No other circuits, patents, or licenses are implied. This product is intended for use in normal commercial applications. Any other applications such as those requiring extended temperature range, high reliability, or other extraordinary environmental requirements are not recommended without additional processing by ICS. ICS reserves the right to change any circuitry or specifications without notice. ICS does not authorize or warrant any ICS product for use in life support devices or critical medical instruments.

Innovate with IDT and accelerate your future networks. Contact:

www.IDT.com

For Sales

800-345-7015
408-284-8200
Fax: 408-284-2775

For Tech Support

<product line email>
<product line phone>

Corporate Headquarters

Integrated Device Technology, Inc.
6024 Silver Creek Valley Road
San Jose, CA 95138
United States
800 345 7015
+408 284 8200 (outside U.S.)

Asia Pacific and Japan

Integrated Device Technology
Singapore (1997) Pte. Ltd.
Reg. No. 199707558G
435 Orchard Road
#20-03 Wisma Atria
Singapore 238877
+65 6 887 5505

Europe

IDT Europe, Limited
Prime House
Barnett Wood Lane
Leatherhead, Surrey
United Kingdom KT22 7DE
+44 1372 363 339

