



## High Performance Communication Buffer

### General Description

The **ICS91305** is a high performance, low skew, low jitter clock driver. It uses a phase lock loop (PLL) technology to align, in both phase and frequency, the REF input with the CLKOUT signal. It is designed to distribute high speed clocks in communication systems operating at speeds from 10 to 133 MHz.

**ICS91305** is a zero delay buffer that provides synchronization between the input and output. The synchronization is established via CLKOUT feed back to the input of the PLL. Since the skew between the input and output is less than +/- 350 pS, the part acts as a zero delay buffer.

The **ICS91305** comes in an eight pin 150 mil SOIC package. It has five output clocks. In the absence of REF input, will be in the power down mode. In this mode, the PLL is turned off and the output buffers are pulled low. Power down mode provides the lowest power consumption for a standby condition.

### Features

- Zero input - output delay
- Frequency range 10 - 133 MHz (3.3V)
- 5V tolerant input REF
- High loop filter bandwidth ideal for Spread Spectrum applications.
- Less than 200 ps Jitter between outputs
- Skew controlled outputs
- Skew less than 250 ps between outputs
- Available in 8 pin 150 mil SOIC & 173 mil TSSOP packages
- 3.3V ±10% operation

### Block Diagram

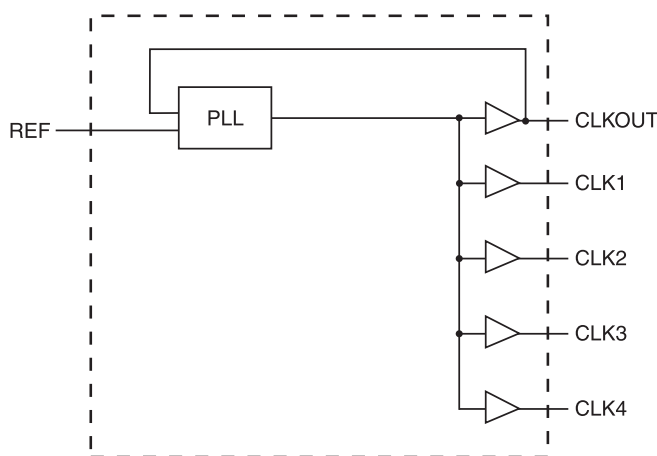

### Pin Configuration

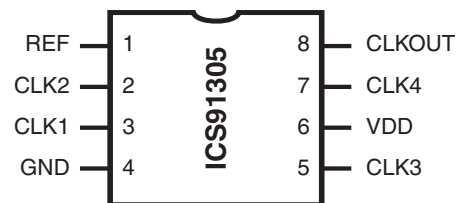

**8 pin SOIC & TSSOP**



---

## Pin Descriptions

PIN NUMBER	PIN NAME	TYPE	DESCRIPTION
1	REF <sup>2</sup>	IN	Input reference frequency, 5V tolerant input.
2	CLK2 <sup>3</sup>	OUT	Buffered clock output
3	CLK1 <sup>3</sup>	OUT	Buffered clock output
4	GND	PWR	Ground
5	CLK3 <sup>3</sup>	OUT	Buffered clock output
6	VDD	PWR	Power Supply (3.3V)
7	CLK4 <sup>3</sup>	OUT	Buffered clock output
8	CLKOUT <sup>3</sup>	OUT	Buffered clock output. Internal feedback on this pin

**Notes:**

1. Guaranteed by design and characterization. Not subject to 100% test.
2. Weak pull-down
3. Weak pull-down on all outputs



### Absolute Maximum Ratings

- Supply Voltage . . . . . 7.0 V
- Logic Inputs (Except REF) . . . . . GND –0.5 V to  $V_{DD} + 0.5$  V
- Logic Input REF . . . . . GND –0.5 V to GND + 5.5 V
- Ambient Operating Temperature . . . . . 0°C to +70°C
- Storage Temperature . . . . . –65°C to +150°C

Stresses above those listed under *Absolute Maximum Ratings* may cause permanent damage to the device. These ratings are stress specifications only and functional operation of the device at these or any other conditions above those listed in the operational sections of the specifications is not implied. Exposure to absolute maximum rating conditions for extended periods may affect product reliability.

### Electrical Characteristics at 3.3V

$V_{DD} = 3.0 - 3.6$  V,  $T_A = 0 - 70^\circ$  C unless otherwise stated

DC Characteristics						
PARAMETER	SYMBOL	TEST CONDITIONS	MIN	TYP	MAX	UNITS
Input Low Voltage	$V_{IL}$				0.8	V
Input High Voltage	$V_{IH}$		2.0			V
Input Low Current	$I_{IL}$	$V_{IN} = 0$ V		19	50.0	$\mu$ A
Input High Current	$I_{IH}$	$V_{IN} = V_{DD}$		0.10	100.0	$\mu$ A
Output Low Voltage <sup>1</sup>	$V_{OL}$	$I_{OL} = 25$ mA		0.25	0.4	V
Output High Voltage <sup>1</sup>	$V_{OH}$	$I_{OH} = 25$ mA	2.4	2.9		V
Power Down Supply Current	$I_{DD}$	REF = 0 MHz		0.3	50.0	$\mu$ A
Supply Current	$I_{DD}$	Unloaded outputs at 66.66 MHz SEL inputs at $V_{DD}$ or GND		30.0	40.0	mA

Notes:

1. Guaranteed by design and characterization. Not subject to 100% test.
2. All Skew specifications are measured with a 50Ω transmission line, load terminated with 50Ω to 1.4V.
3. Duty cycle measured at 1.4V.
4. Skew measured at 1.4V on rising edges. Loading must be equal on outputs.



## Switching Characteristics

PARAMETER	SYMBOL	CONDITION	MIN	TYP	MAX	UNITS
Output period	t1	With CL = 30pF	100.00 (10)		7.5 (133)	ns (MHz)
Input period	t1	With CL = 30pF	100.00 (10)		7.5 (133)	ns (MHz)
Duty Cycle <sup>1</sup>	Dt1	Measured at 1.4V; CL = 30pF	40.0	50	60	%
Duty Cycle <sup>1</sup>	Dt2	Measured at VDD/2 Fout <66.6MHz	45	50	55	%
Rise Time <sup>1</sup>	tr1	Measured between 0.8V and 2.0V; CL=30pF		1.2	1.5	ns
Fall Time <sup>1</sup>	tf1	Measured between 2.0V and 0.8V; CL=30pF		1.2	1.5	ns
Rise Time <sup>1</sup>	tr1	Measured between 0.8V and 2.0V; CL=5pF	1			ns
Fall Time <sup>1</sup>	tf1	Measured between 2.0V and 0.8V; CL=5pF	1			ns
Delay, REF Rising Edge to CLKOUT Rising Edge <sup>1,2</sup>	Dr1	Measured at 1.4V		0	±350	ps
Output to Output Skew <sup>1</sup>	Tskew	All outputs equally loaded, CL = 20pF			250	ps
Device to Device Skew <sup>1</sup>	Tdsk-Tdsk	Measured at VDD/2 on the CLKOUT pins of devices		0	700	ps
Cycle to Cycle Jitter <sup>1</sup>	Tcyc-Tcyc	Measured at 66.66 MHz, loaded outputs			200	ps
PLL Lock Time <sup>1</sup>	tLOCK	Stable power supply, valid clock presented on REF pin			1.0	ms
Jitter; Absolute Jitter <sup>1</sup>	Tjabs	@ 10,000 cycles CL = 30pF	-100	70	100	ps
Jitter; 1 - Sigma <sup>1</sup>	Tj1s	@ 10,000 cycles CL = 30pF		14	30	ps

### Notes:

1. Guaranteed by design and characterization. Not subject to 100% test.
2. REF input has a threshold voltage of 1.4V
3. All parameters expected with loaded outputs



## Output to Output Skew

The skew between CLKOUT and the CLK(1-4) outputs is not dynamically adjusted by the PLL. Since CLKOUT is one of the inputs to the PLL, zero phase difference is maintained from REF to CLKOUT. If all outputs are equally loaded, zero phase difference will be maintained from REF to all outputs.

If applications requiring zero output-output skew, all the outputs must be equally loaded.

If the CLK(1-4) outputs are less loaded than CLKOUT, CLK(1-4) outputs will lead it; and if the CLK(1-4) is more loaded than CLKOUT, CLK(1-4) will lag the CLKOUT.

Since the CLKOUT and the CLK(1-4) outputs are identical, they all start at the same time, but different loads cause them to have different rise times and different times crossing the measurement thresholds.

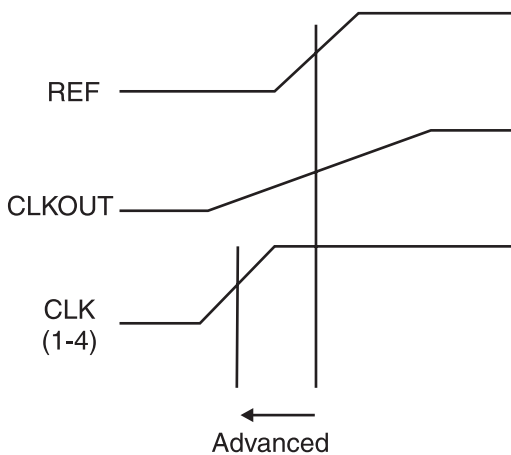
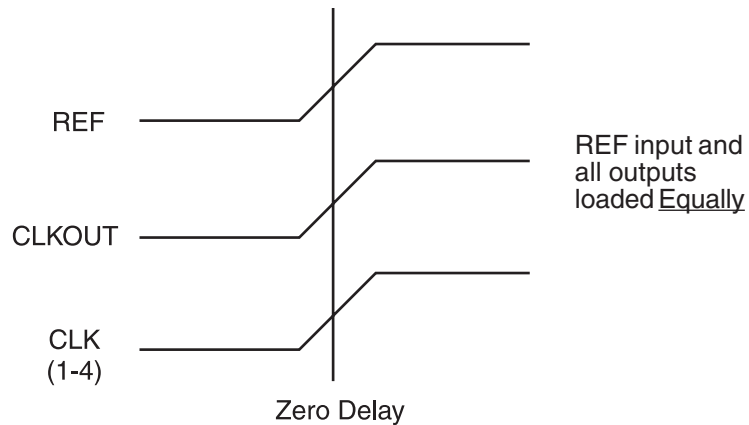

REF input and CLK(1-4) outputs loaded equally, with CLKOUT loaded More.

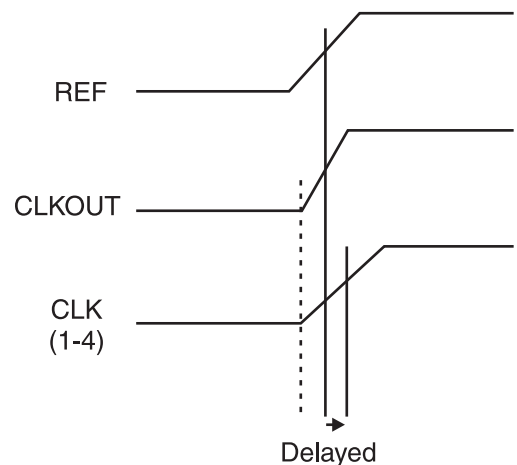

REF input and CLK(1\_4) outputs loaded equally, with CLKOUT loaded Less.

Timing diagrams with different loading configurations

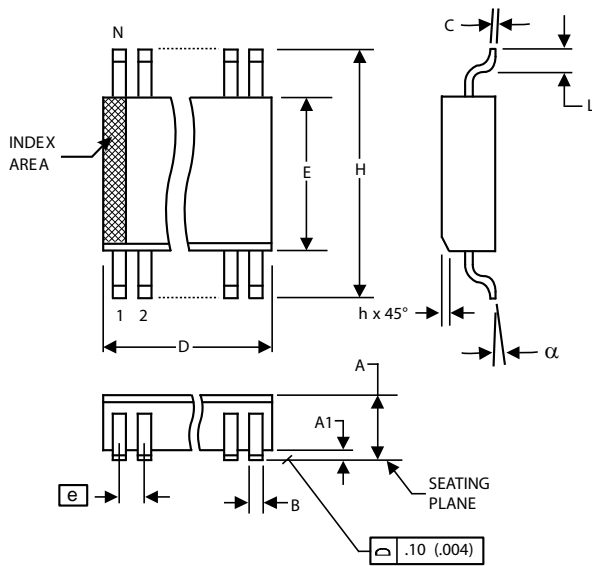

150 mil (Narrow Body) SOIC

150 mil (Narrow Body) SOIC

SYMBOL	In Millimeters		In Inches	
	COMMON DIMENSIONS	COMMON DIMENSIONS	COMMON DIMENSIONS	COMMON DIMENSIONS
A	1.35	1.75	.0532	.0688
A1	0.10	0.25	.0040	.0098
B	0.33	0.51	.013	.020
C	0.19	0.25	.0075	.0098
D	SEE VARIATIONS		SEE VARIATIONS	
E	3.80	4.00	.1497	.1574
e	1.27 BASIC		0.050 BASIC	
H	5.80	6.20	.2284	.2440
h	0.25	0.50	.010	.020
L	0.40	1.27	.016	.050
N	SEE VARIATIONS		SEE VARIATIONS	
alpha	0°	8°	0°	8°

VARIATIONS

N	D mm.		D (inch)	
	MIN	MAX	MIN	MAX
8	4.80	5.00	.1890	.1968

Reference Doc.: JEDEC Publication 95, MS-012  
10-0030

Ordering Information

91305yMLFT

Example:

XXXX y M LFT

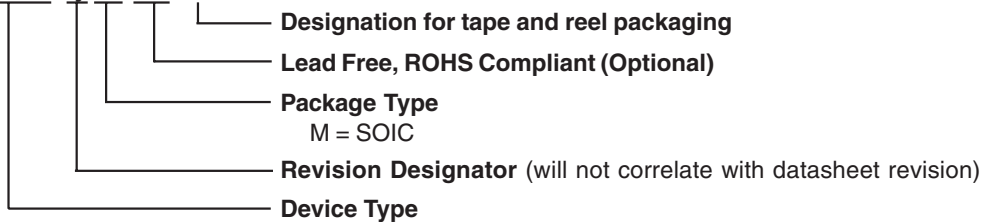





---

## Revision History

Rev.	Issue Date	Description	Page #
G	8/6/2007	Updated Rise/Fall Time.	4
H	12/2/2008	Removed ICS prefix from ordering information	6-7