



# ICS87974I

## LOW SKEW, 1-TO-15, LVCMOS/LVTTL CLOCK GENERATOR

### GENERAL DESCRIPTION

The ICS87974I is a low skew, low jitter 1-to-15 LVCMOS/LVTTL Clock Generator/Zero Delay Buffer. The device has a fully integrated PLL and three banks whose divider ratios can be independently controlled, providing output frequency relationships of 1:1, 2:1, 3:1, 3:2, 3:2:1. In addition, the external feedback connection provides for a wide selection of output-to-input frequency ratios. The CLK0 and CLK1 pins allow for redundant clocking on the input and dynamically switching the PLL between two clock sources.

Guaranteed low jitter and output skew characteristics make the ICS87974I ideal for those applications demanding well defined performance and repeatability.

### FEATURES

- Fully integrated PLL
- Fifteen single ended 3.3V LVCMOS/LVTTL outputs
- Two LVCMOS/LVTTL clock inputs for redundant clock applications
- CLK0 and CLK1 accepts the following input levels: LVCMOS/LVTTL
- Output frequency range: 8.33MHz to 125MHz
- VCO range: 200MHz to 500MHz
- External feedback for "zero delay" clock regeneration
- Cycle-to-cycle jitter:  $\pm 100$ ps (typical)
- Output skew: 350ps (maximum)
- 3.3V operating supply
- -40°C to 85°C ambient operating temperature
- Available in both standard and lead-free RoHS-compliant packages

### PIN ASSIGNMENT

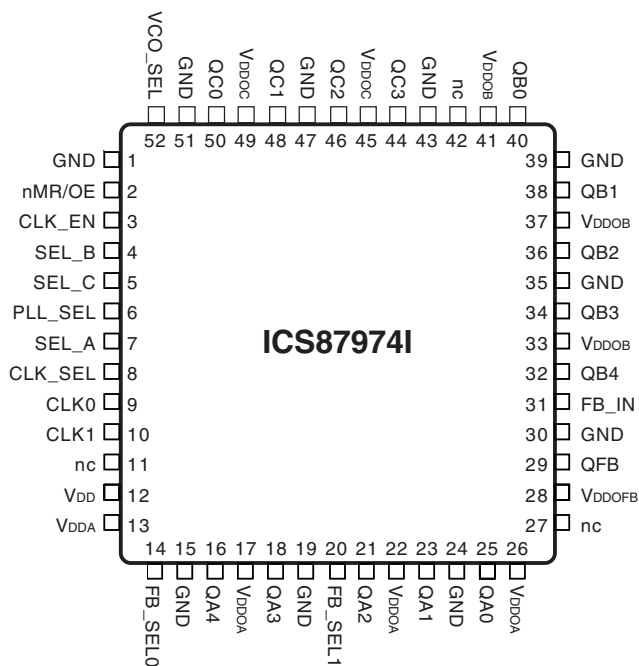

**52-Lead LQFP**  
10mm x 10mm x 1.4mm package body  
**Y package**  
Top View



# ICS87974I

Low Skew, 1-to-15,  
LVCMOS/LVTTL Clock Generator

## BLOCK DIAGRAM

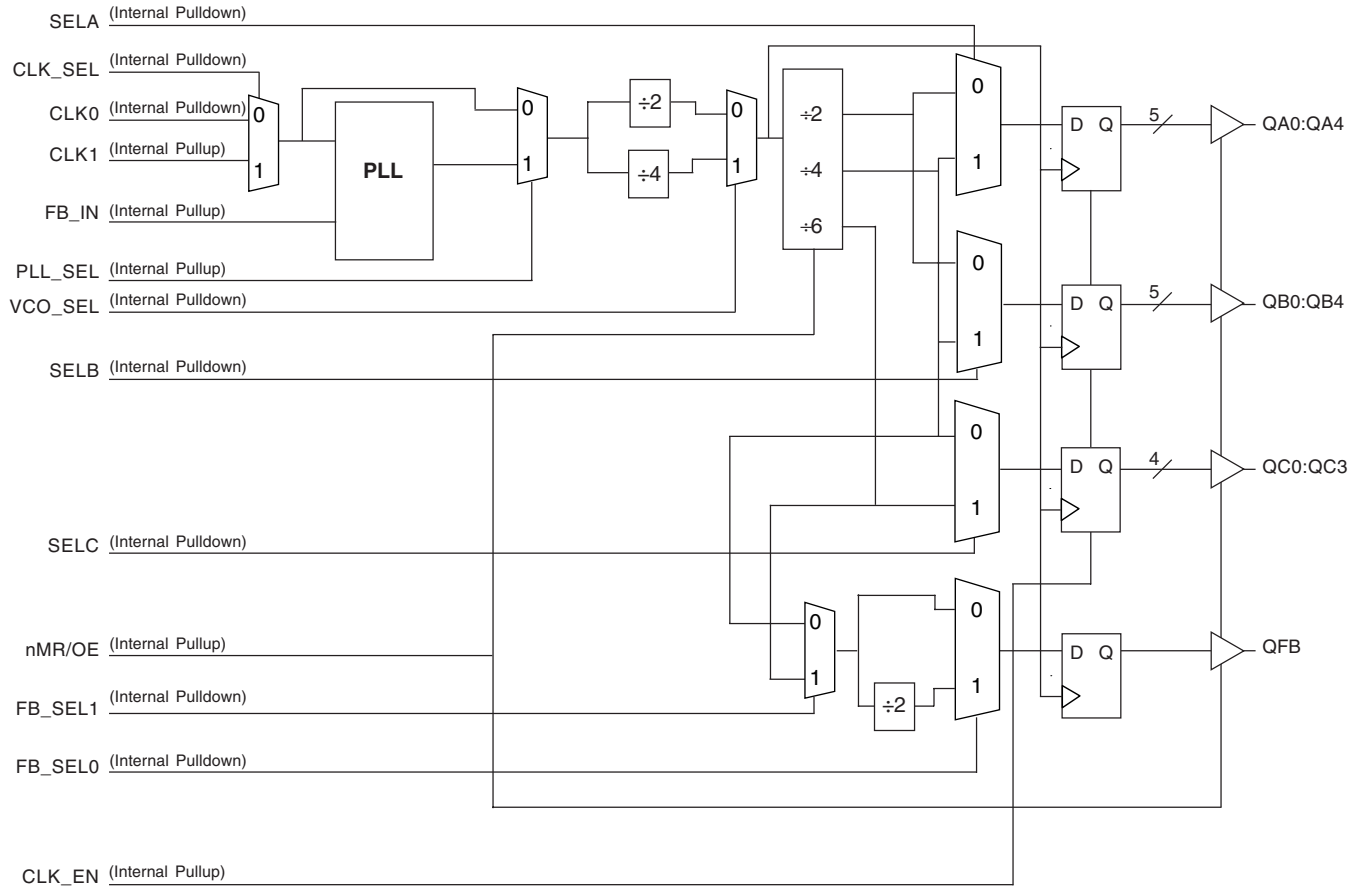



# ICS87974I

LOW SKEW, 1-TO-15,  
LVCMOS/LVTTL CLOCK GENERATOR

## SIMPLIFIED BLOCK DIAGRAM

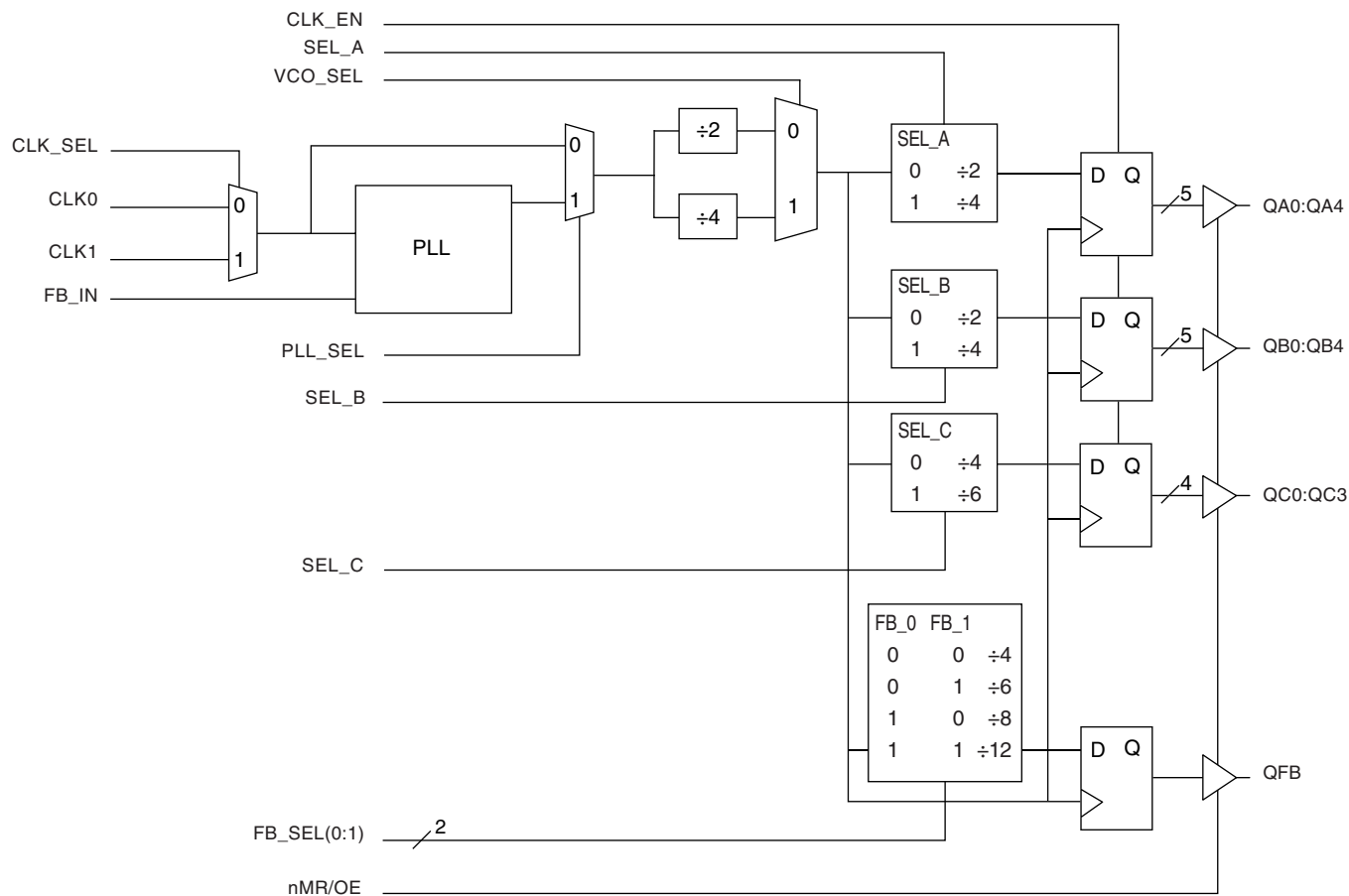



# ICS87974I

## LOW SKEW, 1-TO-15, LVCMOS/LVTTL CLOCK GENERATOR

**TABLE 1. PIN DESCRIPTIONS**

Number	Name	Type		Description
1, 15, 19, 24, 30, 35, 39, 43, 47, 51	GND	Power		Power supply ground.
2	nMR/OE	Input	Pullup	Active High Master Reset. Active LOW output enable. When logic HIGH, the internal dividers are reset and the outputs are tri-stated (HiZ). When logic LOW, the internal dividers and dividers and the outputs are enabled. LVCMOS / LVTTL interface levels.
3	CLK_EN	Input	Pullup	Synchronizing clock enable. When HIGH, clock outputs QAx:QCx are enabled. When LOW, clock outputs QAx:QCx are low. LVCMOS / LVTTL interface levels.
4	SEL_B	Input	Pulldown	Selects divide value for Bank B output as described in Table 3D. LVCMOS / LVTTL interface levels.
5	SEL_C	Input	Pulldown	Selects divide value for Bank C output as described in Table 3D. LVCMOS / LVTTL interface levels.
6	PLL_SEL	Input	Pullup	Selects between the PLL and the reference clock as the input to the dividers. When HIGH, selects PLL. When LOW, selects the reference clock. LVCMOS / LVTTL interface levels.
7	SEL_A	Input	Pulldown	Selects divide value for Bank A output as described in Table 3D. LVCMOS / LVTTL interface levels.
8	CLK_SEL	Input	Pulldown	Clock select input. When HIGH, selects CLK1. When LOW, selects CLK0. LVCMOS / LVTTL interface levels.
9	CLK0	Input	Pulldown	Reference clock input. LVCMOS / LVTTL interface levels.
10	CLK1	Input	Pullup	Reference clock input. LVCMOS / LVTTL interface levels.
11, 27, 42	nc	Unused		No connect.
12	V <sub>DD</sub>	Power		Core supply pin.
13	V <sub>DDA</sub>	Power		Analog supply pin.
14, 20	FB_SELO, FB_SEL1	Input	Pulldown	Selects divide value for Bank feedback output as described in Table 3E. LVCMOS / LVTTL interface levels.
16, 18, 21, 23, 25	QA4, QA3, QA2, QA1, QA0	Output		Bank A clock outputs. 7Ω typical output impedance. LVCMOS / LVTTL interface levels.
17, 22, 26	V <sub>DDOA</sub>	Power		Output supply pins for Bank A clock outputs.
28	V <sub>DDOFB</sub>	Power		Output supply pin for QFB clock output.
29	QFB	Output		Clock output. LVCMOS / LVTTL interface levels.
31	FB_IN	Input	Pullup	Feedback input to phase detector for generating clocks with "zero delay". Connect to pin 29. LVCMOS / LVTTL interface levels.
32, 34, 36, 38, 40	QB4, QB3, QB2, QB1, QB0	Output		Bank B clock outputs. 7Ω typical output impedance. LVCMOS / LVTTL interface levels.
33, 37, 41	V <sub>DDOB</sub>	Power		Output supply pins for Bank B clock outputs.
44, 46, 48, 50	QC3, QC2, QC1, QC0	Output		Bank C clock outputs. 7Ω typical output impedance. LVCMOS / LVTTL interface levels.
45, 49	V <sub>DDOC</sub>	Power		Output supply pins for Bank C clock outputs.
52	VCO_SEL	Input	Pulldown	Selects VCO ÷ 4 when HIGH. Selects VCO ÷ 2 when LOW. LVCMOS / LVTTL interface levels.

NOTE: *Pullup* and *Pulldown* refer to internal input resistors. See Table 2, Pin Characteristics, for typical values.



# ICS87974I

LOW SKEW, 1-TO-15,  
LVCMOS/LVTTL CLOCK GENERATOR

**TABLE 2. PIN CHARACTERISTICS**

Symbol	Parameter	Test Conditions	Minimum	Typical	Maximum	Units
$C_{IN}$	Input Capacitance			4		pF
$R_{PULLUP}$	Input Pullup Resistor			51		K $\Omega$
$R_{PULLDOWN}$	Input Pulldown Resistor			51		K $\Omega$
$C_{PD}$	Power Dissipation Capacitance (per output); Note 1	$V_{DD}, V_{DDA}, V_{DDOx} = 3.465V$			15	pF
$R_{OUT}$	Output Impedance		5	7	12	$\Omega$

NOTE 1:  $V_{DDOx}$  denotes  $V_{DDOA}, V_{DDOB}, V_{DDOC}, V_{DDOFB}$ .

**TABLE 3A. OUTPUT CONTROL PIN FUNCTION TABLE**

Inputs		Outputs			
nMR/OE	CLK_EN	QA0:QA4	QB0:QB4	QC0:QC3	QFB
0	X	HiZ	HiZ	HiZ	HiZ
1	0	LOW	LOW	LOW	Enable
1	1	Enable	Enable	Enable	Enable

**TABLE 3B. OPERATING MODE FUNCTION TABLE**

Inputs	Operating Mode
PLL_SEL	
0	Bypass
1	PLL

**TABLE 3C. PLL INPUT FUNCTION TABLE**

Inputs	
CLK_SEL	PLL Input
0	CLK0
1	CLK1

**TABLE 3D. SELECT PIN FUNCTION TABLE**

SEL_A	QA <sub>x</sub>	SEL_B	QB <sub>x</sub>	SEL_C	QC <sub>x</sub>
0	÷ 2	0	÷ 2	0	÷ 4
1	÷ 4	1	÷ 4	1	÷ 6

**TABLE 3E. FB SELECT FUNCTION TABLE**

Inputs		Outputs
FB_SEL1	FB_SEL0	QFB
0	0	÷ 4
1	0	÷ 6
0	1	÷ 8
1	1	÷ 12

**TABLE 3F. VCO SELECT FUNCTION TABLE**

Inputs	
VCO_SEL	fVCO
0	VCO/2
1	VCO/4



# ICS87974I

LOW SKEW, 1-TO-15,  
LVCMOS/LVTTL CLOCK GENERATOR

## ABSOLUTE MAXIMUM RATINGS

Supply Voltage, $V_{DD}$	4.6V
Inputs, $V_I$	-0.5V to $V_{DD} + 0.5V$
Outputs, $V_O$	-0.5V to $V_{DDO} + 0.5V$
Package Thermal Impedance, $\theta_{JA}$	73.2°C/W (0 lfpm)
Storage Temperature, $T_{STG}$	-65°C to 150°C

NOTE: Stresses beyond those listed under Absolute Maximum Ratings may cause permanent damage to the device. These ratings are stress specifications only. Functional operation of product at these conditions or any conditions beyond those listed in the *DC Characteristics* or *AC Characteristics* is not implied. Exposure to absolute maximum rating conditions for extended periods may affect product reliability.

**TABLE 4A. POWER SUPPLY DC CHARACTERISTICS,  $V_{DD} = V_{DDA} = V_{DDOx} = 3.3V \pm 5\%$ ,  $T_A = -40^\circ C$  TO  $85^\circ C$**

Symbol	Parameter	Test Conditions	Minimum	Typical	Maximum	Units
$V_{DD}$	Core Supply Voltage		3.135	3.3	3.465	V
$V_{DDA}$	Analog Supply Voltage		2.935	3.3	3.465	V
$V_{DDOx}$	Output Supply Voltage; NOTE 1		3.135	3.3	3.465	V
$I_{DD}$	Power Supply Current				121	mA
$I_{DDA}$	Analog Supply Current				15	mA
$I_{DDOx}$	Output Supply Current; NOTE 2				24	mA

NOTE 1:  $V_{DDOx}$  denotes  $V_{DDOAx}$ ,  $V_{DDOBx}$ ,  $V_{DDOCx}$ ,  $V_{DDOFBx}$ .

NOTE 2:  $I_{DDOx}$  denotes  $I_{DDOAx}$ ,  $I_{DDOBx}$ ,  $I_{DDOCx}$ ,  $I_{DDOFBx}$ .

**TABLE 4B. LVCMOS/LVTTL DC CHARACTERISTICS,  $V_{DD} = V_{DDA} = V_{DDOx} = 3.3V \pm 5\%$ ,  $T_A = -40^\circ C$  TO  $85^\circ C$**

Symbol	Parameter	Test Conditions	Minimum	Typical	Maximum	Units
$V_{IH}$	Input High Voltage	SEL_A:SEL_C, nMR/OE, VCO_SEL, PLL_SEL, CLK_SEL, CLK_EN, FB_SEL0, FB_SEL1, FB_IN	2		$V_{DD}$	V
		CLK0, CLK1	2		$V_{DD}$	V
$V_{IL}$	Input Low Voltage	SEL_A:SEL_C, nMR/OE, VCO_SEL, PLL_SEL, CLK_SEL, CLK_EN, FB_SEL0, FB_SEL1, FB_IN			0.8	V
		CLK0, CLK1			0.8	V
$I_{IH}$	Input High Current	FB_SEL0, FB_SEL1, SEL_A:SEL_C, CLK0, VCO_SEL, CLK_SEL	$V_{DD} = V_{IN} = 3.465V$		100	$\mu A$
		CLK1, FB_IN, nMR/OE, PLL_SEL, CLK_EN	$V_{DD} = V_{IN} = 3.465V$		5	$\mu A$
$I_{IL}$	Input Low Current	FB_SEL0, FB_SEL1, SEL_A:SEL_C, CLK0, VCO_SEL, CLK_SEL	$V_{IN} = 0V, V_{DD} = 3.465V$	-5		$\mu A$
		CLK1, FB_IN, nMR/OE, PLL_SEL, CLK_EN	$V_{IN} = 0V, V_{DD} = 3.465V$	-100		$\mu A$
$V_{OH}$	Output High Voltage; NOTE 1		2.4			V
$V_{OL}$	Output Low Voltage; NOTE 1				0.5	V

NOTE 1: Outputs terminated with  $50\Omega$  to  $V_{DDOx}/2$ .



# ICS87974I

LOW SKEW, 1-TO-15,  
LVCMOS/LVTTL CLOCK GENERATOR

**TABLE 5. AC CHARACTERISTICS,  $V_{DD} = V_{DDA} = V_{DDOX} = 3.3V \pm 5\%$ ,  $T_A = -40^\circ C$  TO  $85^\circ C$**

Symbol	Parameter	Test Conditions	Minimum	Typical	Maximum	Units
$f_{MAX}$	Output Frequency	$Qx \div 2, VCO \div 2$			125	MHz
		$Qx \div 4, VCO \div 2$			63	MHz
		$Qx \div 6, VCO \div 2$			42	MHz
$f_{VCO}$	PLL VCO Lock Range; NOTE 5		200		500	MHz
$t_{PD}$	SYNC to Feedback Propagation Delay; NOTE 2, 5	PLL_SEL = 3.3V, fREF = 50MHz	-250		100	ps
t <sub>sk(o)</sub>	Output Skew; NOTE 4, 5	Measured on rising edge at $V_{DDOX}/2$			350	ps
f <sub>jitt(cc)</sub>	Cycle-to-Cycle Jitter; NOTE 5, 6			±100		ps
$t_L$	PLL Lock Time				10	mS
$t_R / t_F$	Output Rise/Fall Time	0.8V to 2.0V	0.15		1.5	ns
$t_{PW}$	Output Pulse Width		$t_{Period}/2 - 800$	$t_{Period}/2 \pm 500$	$t_{Period}/2 + 800$	ps
$t_{EN}$	Output Enable Time		2		10	ns
$t_{DIS}$	Output Disable Time		2		10	ns

All parameters measured at  $f_{MAX}$  unless noted otherwise.

NOTE 1: Measured from the  $V_{DD}/2$  point of the input to the  $V_{DDOX}/2$  of the output.

NOTE 2: Defined as the time difference between the input reference clock and the average feedback input signal when the PLL is locked and the input reference frequency is stable.

NOTE 3: Defined as skew within a bank with equal load conditions.

NOTE 4: Defined as skew between outputs at the same supply voltage and with equal load conditions.

Measured at  $V_{DDOX}/2$ .

NOTE 5: This parameter is defined in accordance with JEDEC Standard 65.

NOTE 6: Measured as peak-to-peak.

## PARAMETER MEASUREMENT INFORMATION

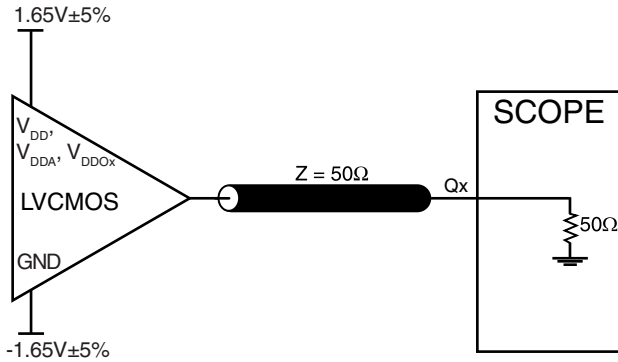

**3.3V OUTPUT LOAD AC TEST CIRCUIT**

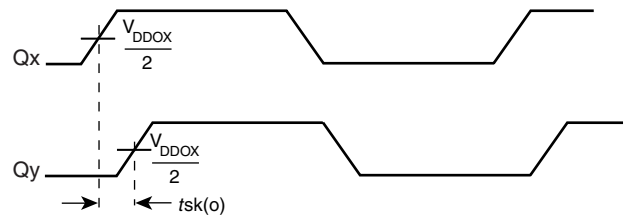

**OUTPUT SKEW**

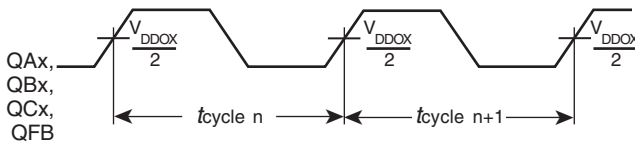

$$t_{jit(cc)} = t_{cycle n} - t_{cycle n+1}$$

1000 Cycles

**CYCLE-TO-CYCLE JITTER**

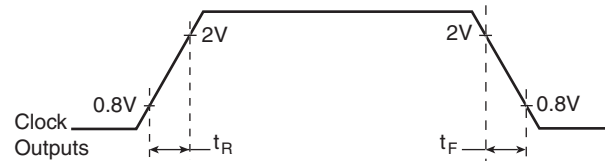

**OUTPUT RISE/FALL TIME**

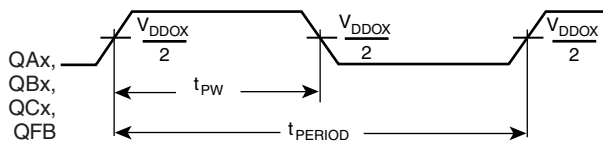

$$odc = \frac{t_{PW}}{t_{PERIOD}}$$

**OUTPUT PULSE WIDTH/PULSE WIDTH PERIOD**

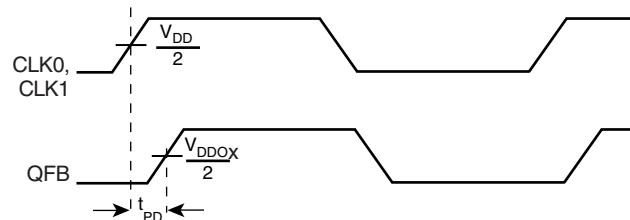

**SYNC TO FEEDBACK PROPAGATION DELAY**

## APPLICATION INFORMATION

### POWER SUPPLY FILTERING TECHNIQUES

As in any high speed analog circuitry, the power supply pins are vulnerable to random noise. The ICS87974I provides separate power supplies to isolate any high switching noise from the outputs to the internal PLL.  $V_{DD}$ ,  $V_{DDA}$ , and  $V_{DDOX}$  should be individually connected to the power supply plane through vias, and bypass capacitors should be used for each pin. To achieve optimum jitter performance, power supply isolation is required. *Figure 1* illustrates how a  $10\Omega$  resistor along with a  $10\mu\text{F}$  and a  $.01\mu\text{F}$  bypass capacitor should be connected to each  $V_{DDA}$  pin. The  $10\Omega$  resistor can also be replaced by a ferrite bead.

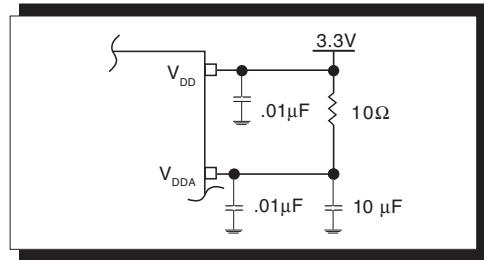

**FIGURE 1. POWER SUPPLY FILTERING**

### RECOMMENDATIONS FOR UNUSED INPUT AND OUTPUT PINS

#### INPUTS:

##### CLK INPUT:

For applications not requiring the use of a clock input, it can be left floating. Though not required, but for additional protection, a  $1\text{k}\Omega$  resistor can be tied from the CLK input to ground.

##### LVCMOS CONTROL PINS:

All control pins have internal pull-ups or pull-downs; additional resistance is not required but can be added for additional protection. A  $1\text{k}\Omega$  resistor can be used.

#### OUTPUTS:

##### LVCMOS OUTPUT:

All unused LVCMOS output can be left floating. We recommend that there is no trace attached.



# ICS87974I

## Low SKEW, 1-TO-15, LVCMOS/LVTTL CLOCK GENERATOR

### LAYOUT GUIDELINE

The schematic of the ICS87974I layout example used in this layout guideline is shown in *Figure 2A*. The ICS87974I recommended PCB board layout for this example is shown in *Figure 2B*. This layout example is used as a general guide-

line. The layout in the actual system will depend on the selected component types, the density of the components, the density of the traces, and the stack up of the P.C. board.

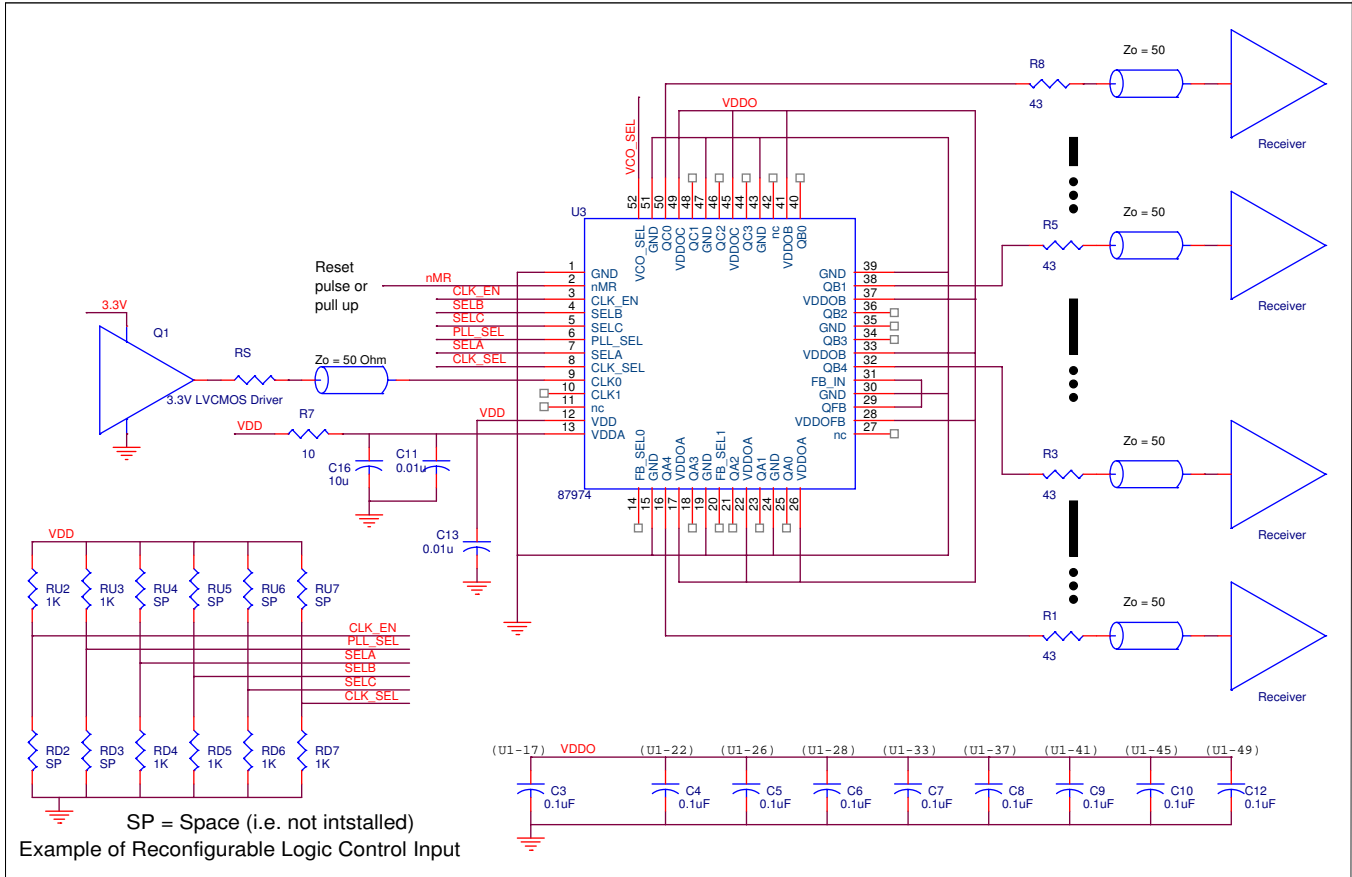

FIGURE 2A. ICS87974I LVCMOS/LVTTL ZERO DELAY BUFFER SCHEMATIC EXAMPLE

The following component footprints are used in this layout example:

All the resistors and capacitors are size 0603.

### POWER AND GROUNDING

Place the decoupling capacitors as close as possible to the power pins. If space allows, placement of the decoupling capacitor on the component side is preferred. This can reduce unwanted inductance between the decoupling capacitor and the power pin caused by the via.

Maximize the power and ground pad sizes and number of vias capacitors. This can reduce the inductance between the power and ground planes and the component power and ground pins.

The RC filter consisting of R7, C11, and C16 should be placed as close to the  $V_{DDA}$  pin as possible.

### CLOCK TRACES AND TERMINATION

Poor signal integrity can degrade the system performance or cause system failure. In synchronous high-speed digital systems, the clock signal is less tolerant to poor signal integrity than other signals. Any ringing on the rising or falling edge or excessive ring back can cause system failure. The shape of the trace and the

trace delay might be restricted by the available space on the board and the component location. While routing the traces, the clock signal traces should be routed first and should be locked prior to routing other signal traces.

- The differential 50Ω output traces should have same length.
- Avoid sharp angles on the clock trace. Sharp angle turns cause the characteristic impedance to change on the transmission lines.
- Keep the clock traces on the same layer. Whenever possible, avoid placing vias on the clock traces. Placement of vias on the traces can affect the trace characteristic impedance and hence degrade signal integrity.
- To prevent cross talk, avoid routing other signal traces in parallel with the clock traces. If running parallel traces is unavoidable, allow a separation of at least three trace widths between the differential clock trace and the other signal trace.
- Make sure no other signal traces are routed between the clock trace pair.
- The series termination resistors should be located as close to the driver pins as possible.

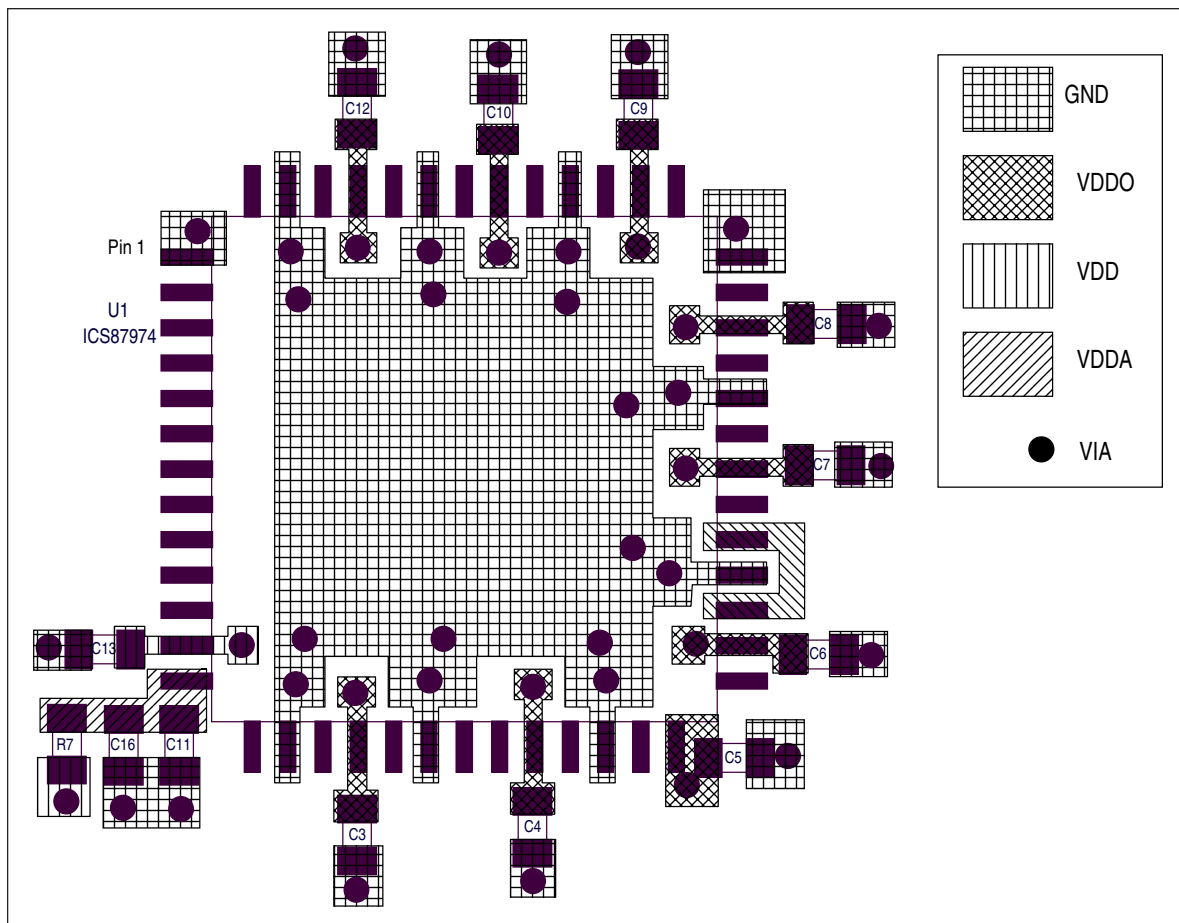

FIGURE 2B. PCB BOARD LAYOUT FOR ICS87974I



## RELIABILITY INFORMATION

TABLE 6.  $\theta_{JA}$  VS. AIR FLOW TABLE FOR 52 LEAD LQFP

$\theta_{JA}$ by Velocity (Linear Feet per Minute)			
	0	200	500
Single-Layer PCB, JEDEC Standard Test Boards	58.0°C/W	47.1°C/W	42.0°C/W
Multi-Layer PCB, JEDEC Standard Test Boards	42.3°C/W	36.4°C/W	34.0°C/W

**NOTE:** Most modern PCB designs use multi-layered boards. The data in the second row pertains to most designs.

### TRANSISTOR COUNT

The transistor count for ICS87974I is: 4225

PACKAGE OUTLINE - Y SUFFIX FOR 52 LEAD LQFP

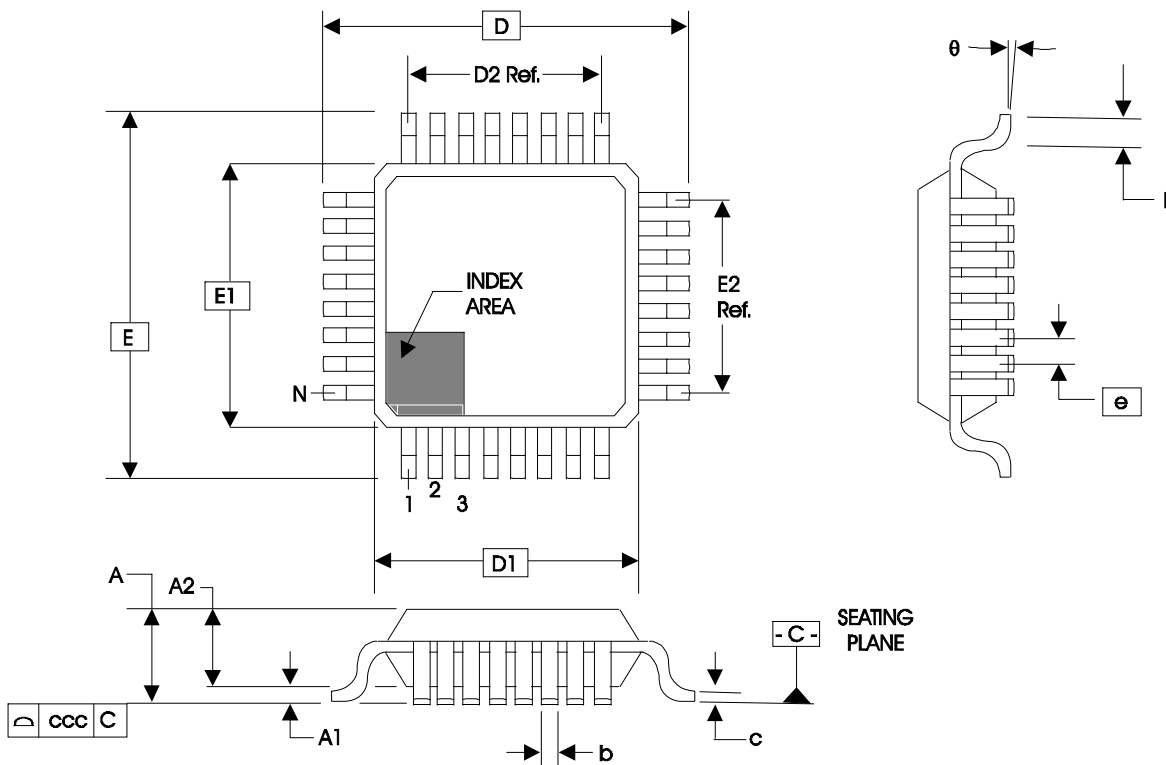

TABLE 7. PACKAGE DIMENSIONS

JEDEC VARIATION ALL DIMENSIONS IN MILLIMETERS			
SYMBOL	BCC		
	MINIMUM	NOMINAL	MAXIMUM
N	52		
A	--	--	1.60
A1	0.05	--	0.15
A2	1.35	1.40	1.45
b	0.22	0.32	0.38
c	0.09	--	0.20
D	12.00 BASIC		
D1	10.00 BASIC		
E	12.00 BASIC		
E1	10.00 BASIC		
e	0.65 BASIC		
L	0.45	--	0.75
θ	0°	--	7°
ccc	--	--	0.08

Reference Document: JEDEC Publication 95, MS-026



# ICS87974I

LOW SKEW, 1-TO-15,  
LVCMOS/LVTTL CLOCK GENERATOR

TABLE 8. ORDERING INFORMATION

Part/Order Number	Marking	Package	Shipping Packaging	Temperature
87974CYI	ICS87974CYI	52 Lead LQFP	tray	-40°C to 85°C
87974CYIT	ICS87974CYI	52 Lead LQFP	500 tape & reel	-40°C to 85°C
87974CYILF	ICS87974CYILF	52 Lead "Lead-Free" LQFP	tray	-40°C to 85°C
87974CYILFT	ICS87974CYILF	52 Lead "Lead-Free" LQFP	500 tape & reel	-40°C to 85°C

NOTE: Parts that are ordered with an "LF" suffix to the part number are the Pb-Free configuration and are RoHS compliant.

While the information presented herein has been checked for both accuracy and reliability, Integrated Device Technology, Inc. (IDT) assumes no responsibility for either its use or for infringement of any patents or other rights of third parties, which would result from its use. No other circuits, patents, or licenses are implied. This product is intended for use in normal commercial and industrial applications. Any other applications such as those requiring high reliability, or other extraordinary environmental requirements are not recommended without additional processing by IDT. IDT reserves the right to change any circuitry or specifications without notice. IDT does not authorize or warrant any IDT product for use in life support devices or critical medical instruments.



**ICS87974I**  
 LOW SKEW, 1-TO-15,  
 LVCMOS/LVTTL CLOCK GENERATOR

REVISION HISTORY SHEET				
Rev	Table	Page	Description of Change	Date
A		10 & 11	Added Layout Guideline and PCB Board Layout.	4/2/02
A		3	Added simplified block diagram.	4/4/02
A	T7	12	Revised Package Outline drawing. Corrected Package Dimensions table to correspond with the Package Outline drawing. Update format throughout datasheet.	11/15/02
B	T1	4	Pin Description table - updated nMR/OE and $V_{DDOX}$ pin descriptions.	3/20/03
	T4A	6	3V Power Supply table - changed $V_{DD}$ parameter to "Core..." from "Positive...". Changed $I_{DD}$ max. limit from 105mA max. to 118mA max., and $I_{DDOX}$ from 20mA max. to 22mA max.	
B	T2	5	Pin Characteristics Table - changed $C_{IN}$ 8pF max. to 4pF typical.	5/15/03
	T3E	5	FB Select Function Table - switched FB_SELx headings, FB_SEL1 heading is in column 1, FB_SEL0 heading is in column 2.	
B	T2	5 12	Pin Characteristics Table - added $R_{OUT}$ , Output Impedance row. Revised Package Outline.	7/9/03
C	T4A	6	Change from die rev. A to B on part marking throughout data sheet. Change max. temperature to 70°C down from 85°C throughout data sheet. Power Supply DC Characteristics table - adjusted: $V_{DDA}$ from 3.135V min. to 2.9375V min., $I_{DD}$ from 118mA max. to 125mA max., and $I_{DDOX}$ from 22mA max. to 25mA max.	7/23/03
D	T4A	6	Through out the data sheet the maximum temperature was changed from 70°C to 85°C. Power Supply DC Characteristics Table - $I_{DD}$ changed from 125mA max. to 121mA max. and $I_{DDOX}$ changed from 25mA max. to 24mA max.	8/4/03
D		2 & 3	Swaped labels for FB_SEL0 and FB_SEL1 in the Block Diagram and Simplified Block Diagram.	2/9/04
D	T3E	5	Corrected FB Select Function Table.	6/9/04
D	T8	13	Ordering Information Table - added Lead-Free part number.	10/11/04
D	T8	9	Added <i>Recommendations for Unused Input and Output Pins</i> .	1/19/06
		14	Ordering Information Table - part number and order number is now a revision C. Corrected lead-free part number and marking, and added lead-free note.	
E	T8	14 16	Updated datasheet's header/footer with IDT from ICS. Removed ICS prefix from Part/Order Number column. Added Contact Page.	7/26/10



**ICS87974I**  
LOW SKEW, 1-TO-15,  
LVCMOS/LVTTL CLOCK GENERATOR

---

**We've Got Your Timing Solution.**



6024 Silver Creek Valley Road  
San Jose, CA 95138

**Sales**  
800-345-7015 (inside USA)  
+408-284-8200 (outside USA)  
Fax: 408-284-2775

**Tech Support**  
netcom@idt.com