



# 1:1 DIFFERENTIAL-TO-LVDS ZERO DELAY CLOCK GENERATOR

# ICS874S02I

## General Description



The ICS874S02I is a highly versatile 1:1 Differential-to-LVDS Clock Generator and a member of the HiPerClockS™ family of High Performance Clock Solutions from IDT. The ICS874S02I has a fully integrated PLL and can be configured as a zero

delay buffer, multiplier or divider, and has an output frequency range of 62.5MHz to 1GHz. The reference divider, feedback divider and output divider are each programmable, thereby allowing for the following output-to-input frequency ratios: 8:1, 4:1, 2:1, 1:1, 1:2, 1:4, 1:8. The external feedback allows the device to achieve "zero delay" between the input clock and the output clocks. The PLL\_SEL pin can be used to bypass the PLL for system test and debug purposes. In bypass mode, the reference clock is routed around the PLL and into the internal output dividers.

## Features

- One differential LVDS output pair and one differential feedback output pair
- One differential clock input pair
- CLK/nCLK can accept the following differential input levels: LVPECL, LVDS, LVHSTL, SSTL
- Input frequency range: 62.5MHz to 1GHz
- Output frequency range: 62.5MHz to 1GHz
- VCO range: 500MHz - 1GHz
- External feedback for "zero delay" clock regeneration with configurable frequencies
- Programmable dividers allow for the following output-to-input frequency ratios: 8:1, 4:1, 2:1, 1:1, 1:2, 1:4, 1:8
- Cycle-to-cycle jitter: 35ps (maximum)
- Static phase offset: ±100ps
- Full 3.3V supply mode
- -40°C to 85°C ambient operating temperature
- Available in standard (RoHS 5) package

## Block Diagram

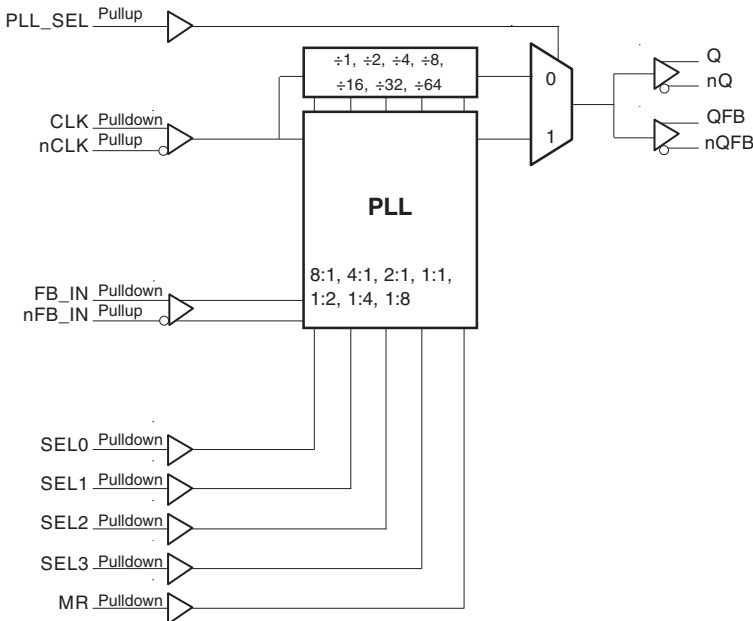

## Pin Assignment

CLK	1	20	SEL1
nCLK	2	19	SEL0
MR	3	18	VDD
nFB_IN	4	17	PLL_SEL
FB_IN	5	16	VDDA
SEL2	6	15	SEL3
VDDO	7	14	GND
nQFB	8	13	Q
QFB	9	12	nQ
GND	10	11	VDDO

### ICS874S02I

### 20-Lead SOIC

7.5mm x 12.8mm x 2.3mm package body

### M Package

### Top View

**Table 1. Pin Descriptions**

Number	Name	Type		Description
1	CLK	Input	Pulldown	Non-inverting differential clock input.
2	nCLK	Input	Pullup	Inverting differential clock input.
3	MR	Input	Pulldown	Active HIGH Master Reset. When logic HIGH, the internal dividers are reset causing the true outputs Q and QFB to go low and the inverted outputs nQ and nQFB to go high. When logic LOW, the internal dividers and the outputs are enabled. LVCMOS / LVTTTL interface levels.
4	nFB_IN	Input	Pullup	Inverting differential feedback input to phase detector for regenerating clocks with "Zero Delay." Connect to pin 8.
5	FB_IN	Input	Pulldown	Non-inverted differential feedback input to phase detector for regenerating clocks with "Zero Delay." Connect to pin 9.
6, 15, 19, 20	SEL2, SEL3, SEL0, SEL1	Input	Pulldown	Determines output divider values in Table 3. LVCMOS / LVTTTL interface levels.
7, 11	V <sub>DDO</sub>	Power		Output supply pins.
8, 9	nQFB, QFB	Output		Differential feedback output pair. HSTL interface levels.
10, 14	GND	Power		Power supply ground.
12, 13	nQ, Q	Output		Differential clock output pair. HSTL interface levels.
16	V <sub>DDA</sub>	Power		Analog supply pin.
17	PLL_SEL	Input	Pullup	PLL select. Selects between the PLL and reference clock as the input to the dividers. When LOW, selects reference clock. When HIGH, selects PLL. LVCMOS/LVTTTL interface levels.
18	V <sub>DD</sub>	Power		Core supply pin.

NOTE: *Pullup and Pulldown* refer to internal input resistors. See Table 2, *Pin Characteristics*, for typical values.

**Table 2. Pin Characteristics**

Symbol	Parameter	Test Conditions	Minimum	Typical	Maximum	Units
C <sub>IN</sub>	Input Capacitance			2		pF
R <sub>PULLUP</sub>	Input Pullup Resistor			50		kΩ
R <sub>PULLDOWN</sub>	Input Pulldown Resistor			50		kΩ

## Function Tables

Table 3A. Control Input Function Table

Inputs					Outputs PLL_SEL = 1 PLL Enable Mode
SEL3	SEL2	SEL1	SEL0	Reference Frequency Range (MHz)*	Q/nQ
0	0	0	0	500 - 1000	÷1
0	0	0	1	250 - 500	÷1
0	0	1	0	125 - 250	÷1
0	0	1	1	62.5 - 125	÷1
0	1	0	0	500 - 1000	÷2
0	1	0	1	250 - 500	÷2
0	1	1	0	125 - 250	÷2
0	1	1	1	500 - 1000	÷4
1	0	0	0	250 - 500	÷4
1	0	0	1	500 - 1000	÷8
1	0	1	0	250 - 500	x2
1	0	1	1	125 - 250	x2
1	1	0	0	62.5 - 125	x2
1	1	0	1	125 - 250	x4
1	1	1	0	62.5 - 125	x4
1	1	1	1	62.5 - 125	x8

\*NOTE: VCO frequency range for all configurations above is 500MHz to 1GHz.

Table 3B. PLL Bypass Function Table

Inputs				Outputs PLL_SEL = 0 PLL Bypass Mode
SEL3	SEL2	SEL1	SEL0	Q/nQ
0z	0	0	0	÷4
0	0	0	1	÷4
0	0	1	0	÷4
0	0	1	1	÷8
0	1	0	0	÷8
0	1	0	1	÷8
0	1	1	0	÷16
0	1	1	1	÷16
1	0	0	0	÷32
1	0	0	1	÷64
1	0	1	0	÷2
1	0	1	1	÷2
1	1	0	0	÷4
1	1	0	1	÷1
1	1	1	0	÷2
1	1	1	1	÷1

## Absolute Maximum Ratings

NOTE: Stresses beyond those listed under *Absolute Maximum Ratings* may cause permanent damage to the device. These ratings are stress specifications only. Functional operation of product at these conditions or any conditions beyond those listed in the *DC Characteristics* or *AC Characteristics* is not implied. Exposure to absolute maximum rating conditions for extended periods may affect product reliability.

Item	Rating
Supply Voltage, $V_{DD}$	4.6V
Inputs, $V_I$	-0.5V to $V_{DD} + 0.5V$
Outputs, $I_O$ (LVDS) Continuous Current Surge Current	10mA 15mA
Package Thermal Impedance, $\theta_{JA}$	64.7°C/W (0 lfpm)
Storage Temperature, $T_{STG}$	-65°C to 150°C

## DC Electrical Characteristics

**Table 4A. LVDS Power Supply DC Characteristics,  $V_{DD} = V_{DDO} = 3.3V \pm 5\%$ ,  $T_A = -40^\circ\text{C}$  to  $85^\circ\text{C}$**

Symbol	Parameter	Test Conditions	Minimum	Typical	Maximum	Units
$V_{DD}$	Core Supply Voltage		3.135	3.3	3.465	V
$V_{DDA}$	Analog Supply Voltage		$V_{DD} - 0.20$	3.3	$V_{DD}$	V
$V_{DDO}$	Output Supply Voltage		3.135	3.3	3.465	V
$I_{DD}$	Power Supply Current				97	mA
$I_{DDA}$	Analog Supply Current				20	mA
$I_{DDO}$	Output Supply Current				40	mA

**Table 4B. LVCMOS/LVTTL DC Characteristics,  $V_{DD} = V_{DDO} = 3.3V \pm 5\%$ ,  $T_A = -40^\circ\text{C}$  to  $85^\circ\text{C}$**

Symbol	Parameter	Test Conditions	Minimum	Typical	Maximum	Units
$V_{IH}$	Input High Voltage		2.2		$V_{DD} + 0.3$	V
$V_{IL}$	Input Low Voltage		-0.3		0.8	V
$I_{IH}$	Input High Current	MR, SEL[0:3]	$V_{DD} = V_{IN} = 3.465V$		150	$\mu\text{A}$
		PLL_SEL	$V_{DD} = V_{IN} = 3.465V$		10	$\mu\text{A}$
$I_{IL}$	Input Low Current	MR, SEL[0:3]	$V_{DD} = 3.465V, V_{IN} = 0V$	-10		$\mu\text{A}$
		PLL_SEL	$V_{DD} = 3.465V, V_{IN} = 0V$	-150		$\mu\text{A}$

**Table 4C. Differential DC Characteristics,  $V_{DD} = V_{DDO} = 3.3V \pm 5\%$ ,  $T_A = -40^\circ\text{C}$  to  $85^\circ\text{C}$** 

Symbol	Parameter	Test Conditions	Minimum	Typical	Maximum	Units
$I_{IH}$	Input High Current	CLK, FB_IN	$V_{DD} = V_{IN} = 3.465V$		150	$\mu\text{A}$
		nCLK, nFB_IN	$V_{DD} = V_{IN} = 3.465V$		10	$\mu\text{A}$
$I_{IL}$	Input Low Current	CLK, FB_IN	$V_{DD} = 3.465V, V_{IN} = 0V$	-10		$\mu\text{A}$
		nCLK, nFB_IN	$V_{DD} = 3.465V, V_{IN} = 0V$	-150		$\mu\text{A}$
$V_{PP}$	Peak-to-Peak Input Voltage; NOTE 1		0.15		1.3	V
$V_{CMR}$	Common Mode Input Voltage; NOTE 1, 2		GND + 0.5		$V_{DD} - 0.85$	V

NOTE 1:  $V_{IL}$  should not be less than -0.3V.NOTE 2: Common mode input voltage is defined as  $V_{IH}$ .**Table 4D. LVDS DC Characteristics,  $V_{DD} = V_{DDO} = 3.3V \pm 5\%$ ,  $T_A = -40^\circ\text{C}$  to  $85^\circ\text{C}$** 

Symbol	Parameter	Test Conditions	Minimum	Typical	Maximum	Units
$V_{OD}$	Differential Output Voltage		350	450	550	mV
$\Delta V_{OD}$	$V_{OD}$ Magnitude Change				50	mV
$V_{OS}$	Offset Voltage		1.20	1.33	1.45	V
$\Delta V_{OS}$	$V_{OS}$ Magnitude Change				50	mV

**Table 5. Input Frequency Characteristics,  $V_{DD} = V_{DDO} = 3.3V \pm 5\%$ ,  $T_A = -40^\circ\text{C}$  to  $85^\circ\text{C}$** 

Symbol	Parameter	Test Conditions	Minimum	Typical	Maximum	Units	
$F_{IN}$	Input Frequency	CLK/nCLK	PLL_SEL = 1	62.5		1000	MHz
			PLL_SEL = 0			1000	MHz

**Table 6. AC Characteristics,  $V_{DD} = V_{DDO} = 3.3V \pm 5\%$ ,  $T_A = -40^\circ\text{C}$  to  $85^\circ\text{C}$** 

Parameter	Symbol	Test Conditions	Minimum	Typical	Maximum	Units
$f_{OUT}$	Output Frequency		62.5		1000	MHz
$t_{sk}(\emptyset)$	Static Phase Offset; NOTE 1, 2	PLL_SEL = 1	-100		100	ps
$f_{jit}(cc)$	Cycle-to-Cycle Jitter; NOTE 2				35	ps
$t_L$	PLL Lock Time				1	ms
$t_R / t_F$	Output Rise/Fall Time	20% to 80%	50		250	ps
odc	Output Duty Cycle		47		53	%

NOTE: Electrical parameters are guaranteed over the specified ambient operating temperature range, which is established when device is mounted in a test socket with maintained transverse airflow greater than 500 lpm. Device will meet specifications after thermal equilibrium has been reached under these conditions.

NOTE 1: Defined as the time difference between the input reference clock and the average feedback input signal, when the PLL is locked and the input reference frequency is stable.

NOTE 2: This parameter is defined in accordance with JEDEC Standard 65.

### Parameter Measurement Information

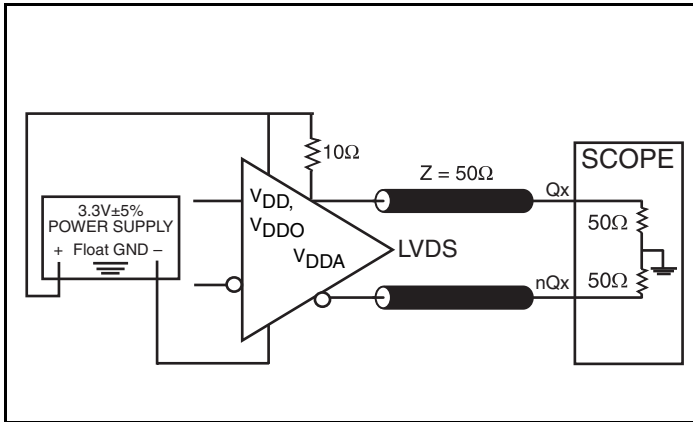

3.3V LVDS Output Load AC Test Circuit

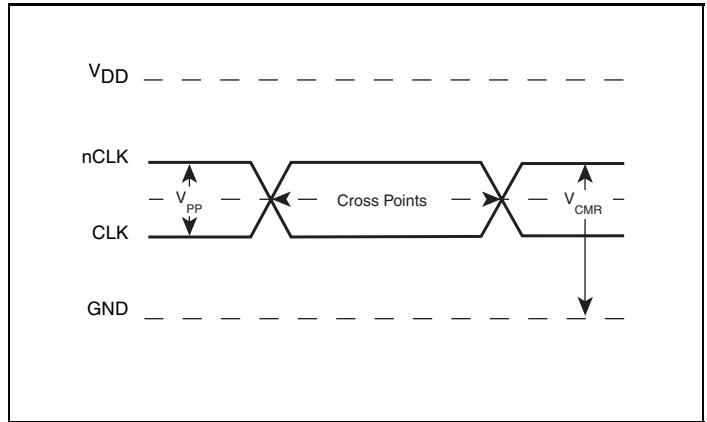

Differential Input Level

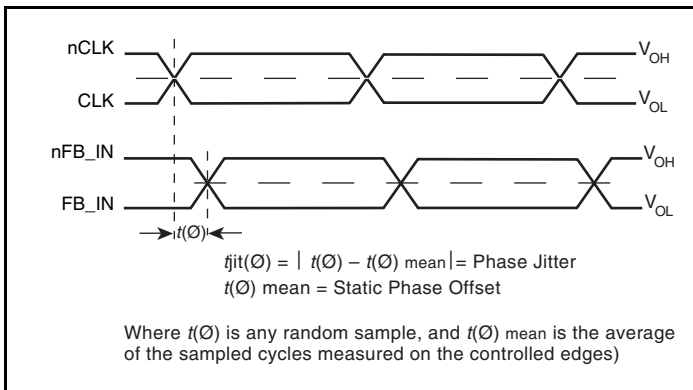

Static Phase Offset

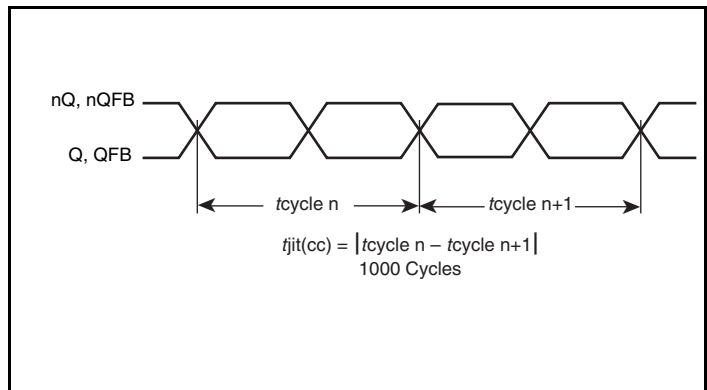

Cycle-to-Cycle Jitter

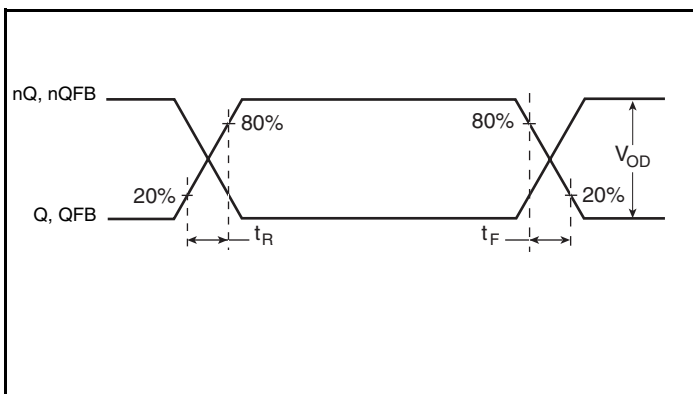

Output Rise/Fall Time

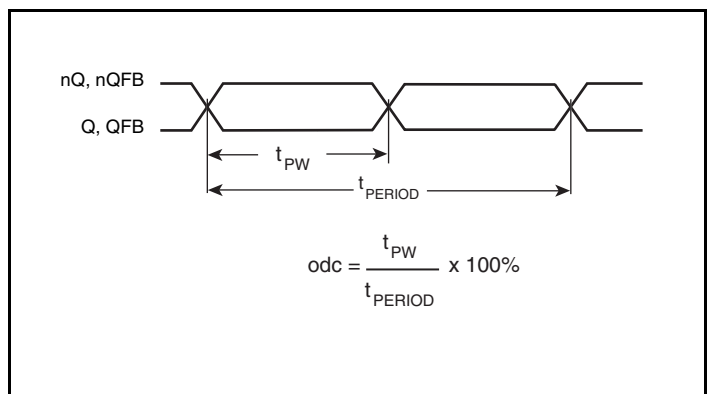

Output Duty Cycle/Pulse Width/Period

## Parameter Measurement Information, continued

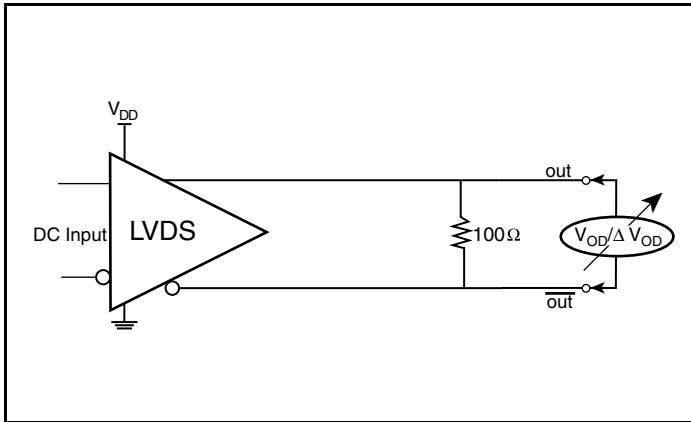

Differential Output Voltage Setup

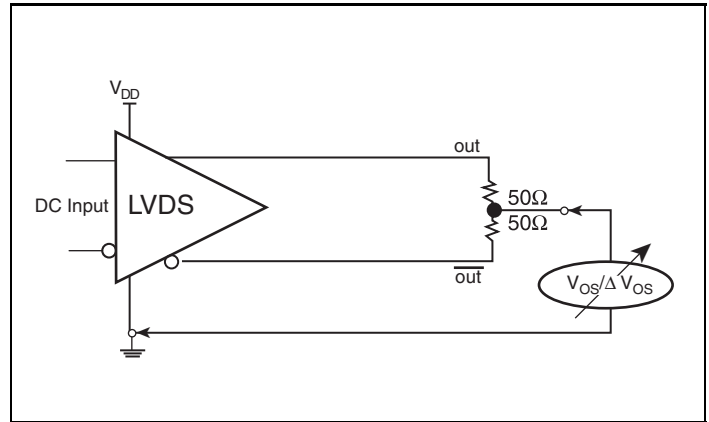

Offset Voltage Setup

## Application Information

### Recommendations for Unused Input and Output Pins

#### Inputs:

##### LVC MOS Control Pins

All control pins have internal pull-ups or pull-downs; additional resistance is not required but can be added for additional protection. A  $1k\Omega$  resistor can be used.

#### Outputs:

##### LVDS Outputs

All unused LVDS output pairs can be either left floating or terminated with  $100\Omega$  across. If they are left floating, there should be no trace attached.

## Power Supply Filtering Technique

As in any high speed analog circuitry, the power supply pins are vulnerable to random noise. To achieve optimum jitter performance, power supply isolation is required. The ICS874S02I provides separate power supplies to isolate any high switching noise from the outputs to the internal PLL.  $V_{DD}$ ,  $V_{DDA}$  and  $V_{DDO}$  should be individually connected to the power supply plane through vias, and  $0.01\mu\text{F}$  bypass capacitors should be used for each pin. *Figure 1* illustrates this for a generic  $V_{DD}$  pin and also shows that  $V_{DDA}$  requires that an additional  $10\Omega$  resistor along with a  $10\mu\text{F}$  bypass capacitor be connected to the  $V_{DDA}$  pin.

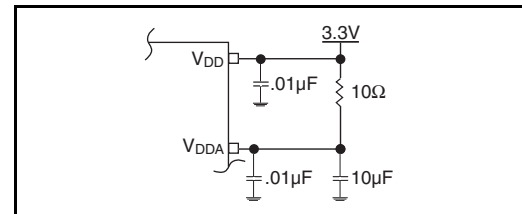

**Figure 1. Power Supply Filtering**

## Wiring the Differential Input to Accept Single-Ended Levels

*Figure 2* shows how the differential input can be wired to accept single-ended levels. The reference voltage  $V_{REF} = V_{DD}/2$  is generated by the bias resistors  $R1$ ,  $R2$  and  $C1$ . This bias circuit should be located as close as possible to the input pin. The ratio of  $R1$  and  $R2$  might need to be adjusted to position the  $V_{REF}$  in the center of the input voltage swing. For example, if the input clock swing is only  $2.5\text{V}$  and  $V_{DD} = 3.3\text{V}$ ,  $V_{REF}$  should be  $1.25\text{V}$  and  $R2/R1 = 0.609$ .

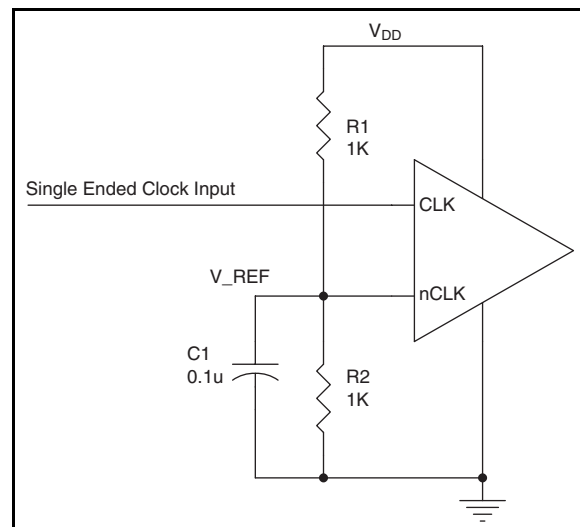
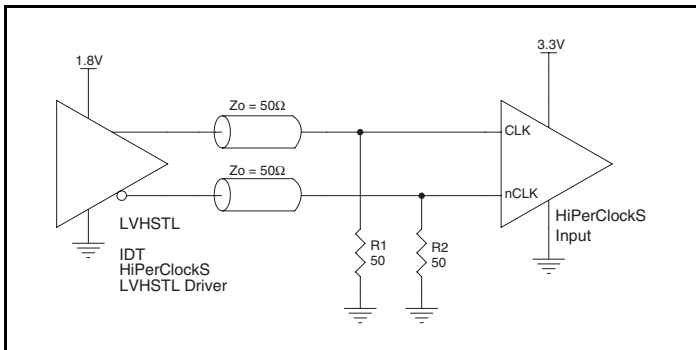

**Figure 2. Single-Ended Signal Driving Differential Input**

### Differential Clock Input Interface

The CLK /nCLK accepts LVDS, LVPECL, LVHSTL, SSTL, and other differential signals. Both signals must meet the  $V_{PP}$  and  $V_{CMR}$  input requirements. Figures 3A to 3E show interface examples for the HiPerClockS CLK/nCLK input driven by the most common driver types. The input interfaces suggested here are examples only. Please consult with the vendor of the driver

component to confirm the driver termination requirements. For example, in Figure 3A, the input termination applies for IDT HiPerClockS open emitter LVHSTL drivers. If you are using an LVHSTL driver from another vendor, use their termination recommendation.



**3A. HiPerClockS CLK/nCLK Input Driven by an IDT Open Emitter HiPerClockS LVHSTL Driver**

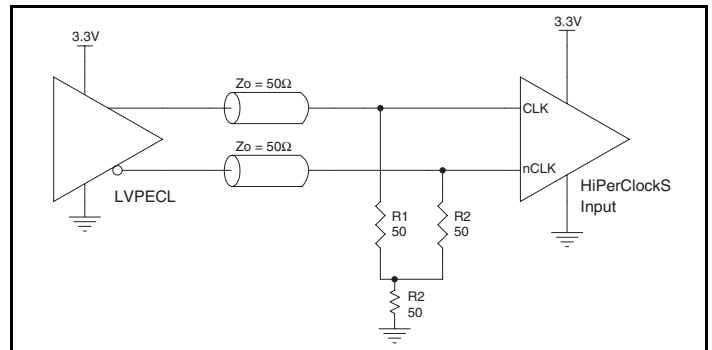

**Figure 3B. HiPerClockS CLK/nCLK Input Driven by a 3.3V LVPECL Driver**

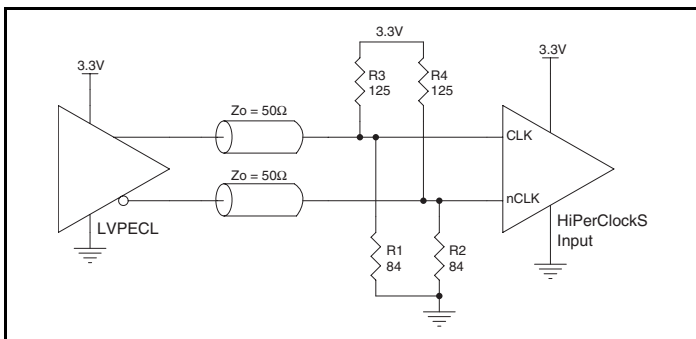

**Figure 3C. HiPerClockS CLK/nCLK Input Driven by a 3.3V LVPECL Driver**

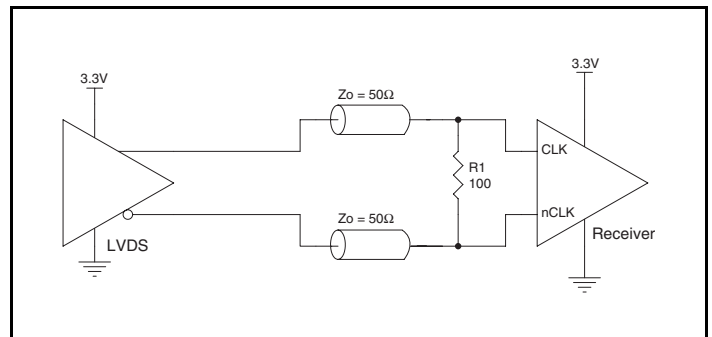

**Figure 3D. HiPerClockS CLK/nCLK Input Driven by a 3.3V LVDS Driver**

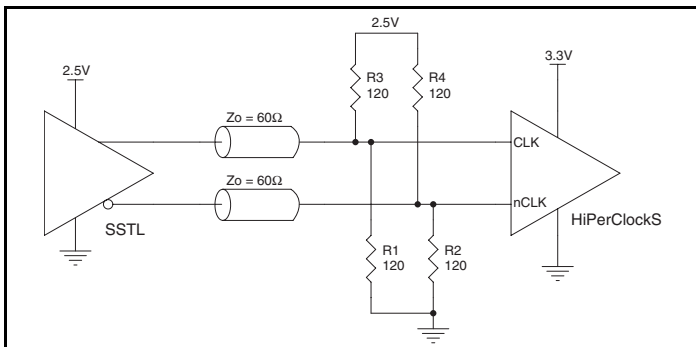

**Figure 3E. HiPerClockS CLK/nCLK Input Driven by a 2.5V SSTL Driver**

### 3.3V LVDS Driver Termination

A general LVDS interface is shown in *Figure 4*. In a 100Ω differential transmission line environment, LVDS drivers require a matched load termination of 100Ω across near the receiver input.

For a multiple LVDS outputs buffer, if only partial outputs are used, it is recommended to terminate the unused outputs.

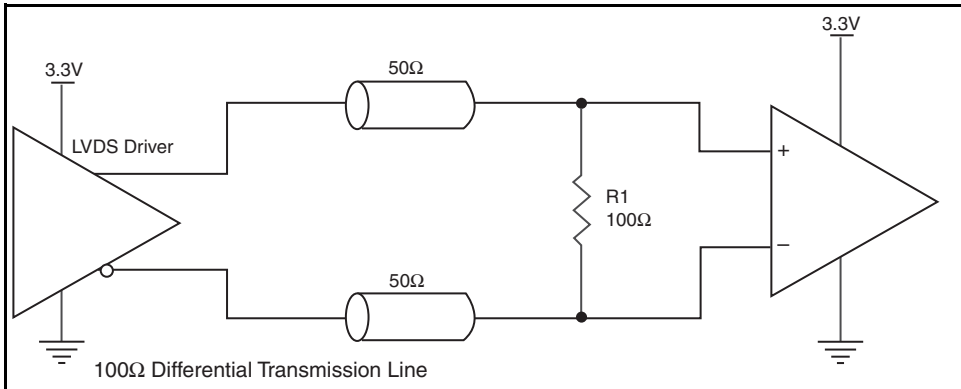

Figure 4. Typical LVDS Driver Termination

### Schematic Example

The schematic of the ICS874S02I layout example is shown in *Figure 5A*. The ICS874S02I recommended PCB board layout for this example is shown in *Figure 5B*. This layout example is used as

a general guideline. The layout in the actual system will depend on the selected component types and the density of the P.C. board.

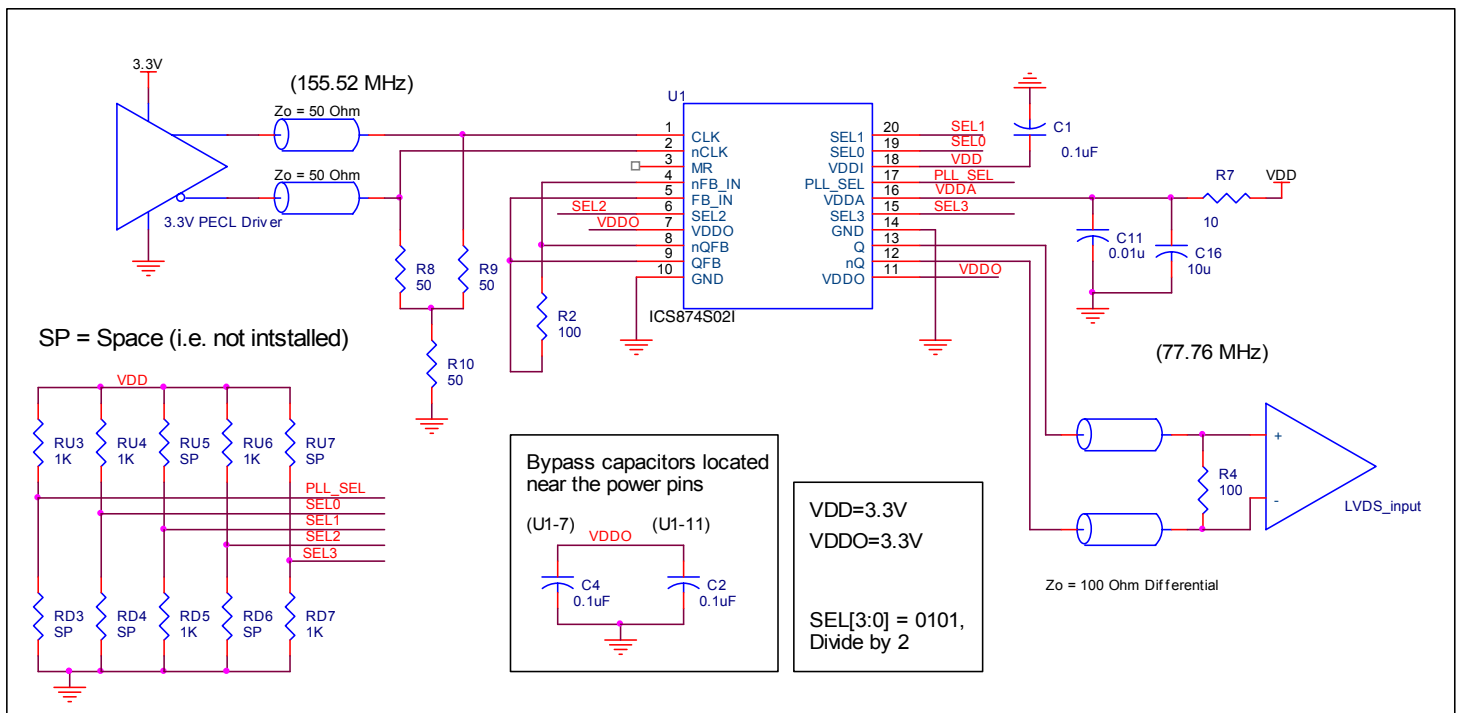

Figure 5A. ICS874S02I LVDS Zero Delay Buffer Schematic Example

The following component footprints are used in this layout example.

All the resistors and capacitors are size 0603.

### Power and Grounding

Place the decoupling capacitors as close as possible to the power pins. If space allows, placement of the decoupling capacitor on the component side is preferred. This can reduce unwanted inductance between the decoupling capacitor and the power pin caused by the via.

Maximize the power and ground pad sizes and number of vias capacitors. This can reduce the inductance between the power and ground planes and the component power and ground pins.

The RC filter consisting of R7, C11, and C16 should be placed as close to the  $V_{DDA}$  pin as possible.

### Clock Traces and Termination

Poor signal integrity can degrade the system performance or cause system failure. In synchronous high-speed digital systems, the clock signal is less tolerant to poor signal integrity than other signals. Any ringing on the rising or falling edge or excessive ring back can cause system failure. The shape of the trace and the

trace delay might be restricted by the available space on the board and the component location. While routing the traces, the clock signal traces should be routed first and should be locked prior to routing other signal traces.

- The 100 $\Omega$  differential output traces should have the same length.
- Avoid sharp angles on the clock trace. Sharp angle turns cause the characteristic impedance to change on the transmission lines.
- Keep the clock traces on the same layer. Whenever possible, avoid placing vias on the clock traces. Placement of vias on the traces can affect the trace characteristic impedance and hence degrade signal integrity.
- To prevent cross talk, avoid routing other signal traces in parallel with the clock traces. If running parallel traces is unavoidable, allow a separation of at least three trace widths between the differential clock trace and the other signal trace.
- Make sure no other signal traces are routed between the clock trace pair.
- The series termination resistors should be located as close to the driver pins as possible.

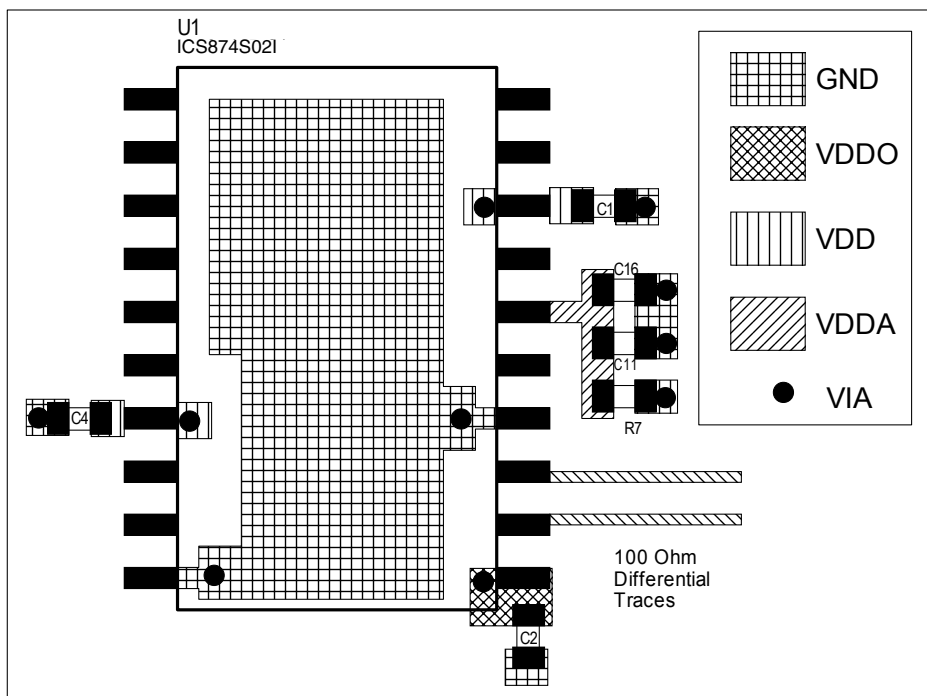

Figure 5B. PCB Board Layout for ICS874S02I

## Power Considerations

This section provides information on power dissipation and junction temperature for the ICS874S02I. Equations and example calculations are also provided.

### 1. Power Dissipation.

The total power dissipation for the ICS874S02I is the sum of the core power plus the analog power plus the power dissipated in the load(s). The following is the power dissipation for  $V_{DD} = 3.3V + 5\% = 3.465V$ , which gives worst case results.

- The maximum current at 85°C is as follows:  
 $I_{DD\_MAX} = 93mA$   
 $I_{DDA\_MAX} = 19mA$   
 $I_{DDO\_MAX} = 36mA$
- Power (core)<sub>MAX</sub> =  $V_{DD\_MAX} * (I_{DD\_MAX} + I_{DDA\_MAX}) = 3.465V * (93mA + 19mA) = 388.08mW$
- Power (outputs)<sub>MAX</sub> =  $V_{DDO\_MAX} * I_{DDO\_MAX} = 3.465V * 36mA = 124.74mW$

**Total Power**<sub>MAX</sub> =  $388.08mW + 124.74mW = 512.82mW$

•

### 2. Junction Temperature.

Junction temperature,  $T_j$ , is the temperature at the junction of the bond wire and bond pad and directly affects the reliability of the device. The maximum recommended junction temperature for HiPerClockS devices is 125°C.

The equation for  $T_j$  is as follows:  $T_j = \theta_{JA} * Pd\_total + T_A$

$T_j$  = Junction Temperature

$\theta_{JA}$  = Junction-to-Ambient Thermal Resistance

$Pd\_total$  = Total Device Power Dissipation (example calculation is in section 1 above)

$T_A$  = Ambient Temperature

In order to calculate junction temperature, the appropriate junction-to-ambient thermal resistance  $\theta_{JA}$  must be used. Assuming no air flow and a multi-layer board, the appropriate value is 64.7°C/W per Table 7 below.

Therefore,  $T_j$  for an ambient temperature of 85°C with all outputs switching is:

$$85^\circ C + 0.513W * 64.7^\circ C/W = 118.2^\circ C. \text{ This is well below the limit of } 125^\circ C.$$

This calculation is only an example.  $T_j$  will obviously vary depending on the number of loaded outputs, supply voltage, air flow and the type of board (single layer or multi-layer).

**Table 7. Thermal Resistance  $\theta_{JA}$  for 20 Lead SOIC, Forced Convection**

Linear Feet per Minute	$\theta_{JA}$ by Velocity		
	0	200	500
Multi-Layer PCB, JEDEC Standard Test Boards	64.7°C/W	56.7°C/W	53.5°C/W

## Reliability Information

Table 8.  $\theta_{JA}$  vs. Air Flow Table for a 20 Lead SOIC

Linear Feet per Minute	$\theta_{JA}$ by Velocity		
	0	200	500
Multi-Layer PCB, JEDEC Standard Test Boards	64.7°C/W	56.7°C/W	53.5°C/W

## Transistor Count

The transistor count for ICS874S02I is: 1358

## Package Outline and Package Dimensions

Package Outline - M Suffix for 20 Lead SOIC

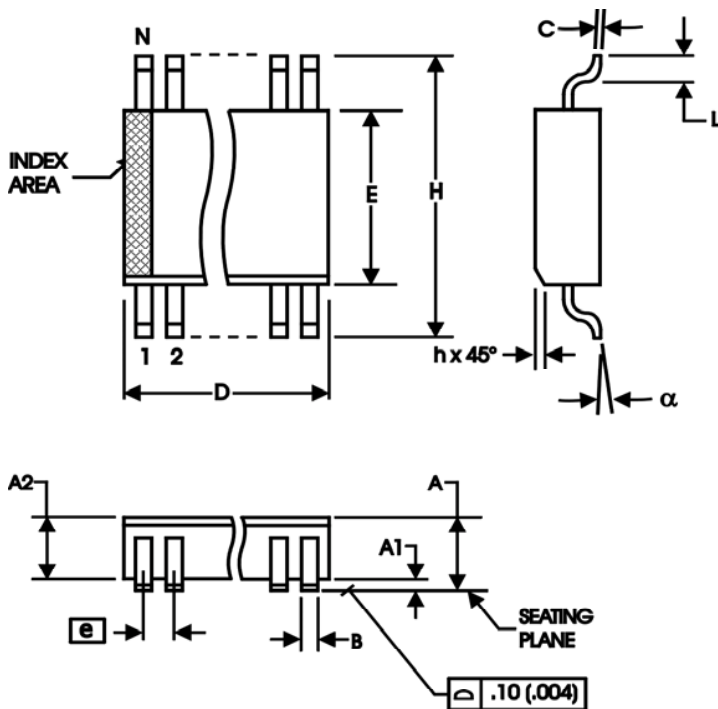

Table 9. Package Dimensions for 20 Lead SOIC

300 Millimeters		
All Dimensions in Millimeters		
Symbol	Minimum	Maximum
N	20	
A		2.65
A1	0.10	
A2	2.05	2.55
B	0.33	0.51
C	0.18	0.32
D	12.60	13.00
E	7.40	7.60
e	1.27 Basic	
H	10.00	10.65
h	0.25	0.75
L	0.40	1.27
$\alpha$	0°	8°

Reference Document: JEDEC Publication 95, MS-013, MS-119

## Ordering Information

Table 10. Ordering Information

Part/Order Number	Marking	Package	Shipping Packaging	Temperature
874S02BMI	ICS874S02BMI	20 Lead SOIC	Tube	-40°C to 85°C
874S02BMIT	ICS874S02BMI	20 Lead SOIC	1000 Tape & Reel	-40°C to 85°C
874S02BMILF	ICS874S02BMILF	Lead-Free, 20 Lead SOIC	Tube	-40°C to 85°C
874S02BMILFT	ICS874S02BMILF	Lead-Free, 20 Lead SOIC	1000 Tape & Reel	-40°C to 85°C

While the information presented herein has been checked for both accuracy and reliability, Integrated Device Technology (IDT) assumes no responsibility for either its use or for the infringement of any patents or other rights of third parties, which would result from its use. No other circuits, patents, or licenses are implied. This product is intended for use in normal commercial and industrial applications. Any other applications, such as those requiring high reliability or other extraordinary environmental requirements are not recommended without additional processing by IDT. IDT reserves the right to change any circuitry or specifications without notice. IDT does not authorize or warrant any IDT product for use in life support devices or critical medical instruments.

ICS874S02I

1:1 DIFFERENTIAL-TO-LVDS ZERO DELAY CLOCK GENERATOR

## Contact Information:

**www.IDT.com**

### Sales

800-345-7015 (inside USA)  
+408-284-8200 (outside USA)  
Fax: 408-284-2775  
[www.IDT.com/go/contactIDT](http://www.IDT.com/go/contactIDT)

### Technical Support

[netcom@idt.com](mailto:netcom@idt.com)  
+480-763-2056

### Corporate Headquarters

Integrated Device Technology, Inc.  
6024 Silver Creek Valley Road  
San Jose, CA 95138  
United States  
800-345-7015 (inside USA)  
+408-284-8200 (outside USA)

