



# 15.625MHZ TO 62.5MHZ, 1:4 LVCMOS/ LVTTTL ZERO DELAY CLOCK BUFFER

# ICS86004

## GENERAL DESCRIPTION



The ICS86004 is a high performance 1:4 LVCMOS/LVTTTL Clock Buffer and a member of the HiPerClockS™ family of High Performance Clock Solutions from IDT. The ICS86004 has a fully integrated PLL and can be configured as zero delay buffer and has an input and output frequency range of 15.625MHz to 62.5MHz. The VCO operates at a frequency range of 250MHz to 500MHz. The external feedback allows the device to achieve “zero delay” between the input clock and the output clocks. The PLL\_SEL pin can be used to bypass the PLL for system test and debug purposes. In bypass mode, the reference clock is routed around the PLL and into the internal output divider.

## FEATURES

- Four LVCMOS/LVTTTL outputs, 7Ω typical output impedance
- Single LVCMOS/LVTTTL clock input
- CLK accepts the following input levels: LVCMOS or LVTTTL
- Output frequency range: 15.625MHz to 62.5MHz
- Input frequency range: 15.625MHz to 62.5MHz
- VCO range: 250MHz to 500MHz
- External feedback for “zero delay” clock regeneration with configurable frequencies
- Fully integrated PLL
- Cycle-to-cycle jitter: 65ps (maximum)
- Output skew: 65ps (maximum)
- Full 3.3V or 2.5V, or 3.3V core/2.5V output operating supply
- 0°C to 70° ambient operating temperature
- Available in both standard and lead-free RoHS compliant packages

## BLOCK DIAGRAM

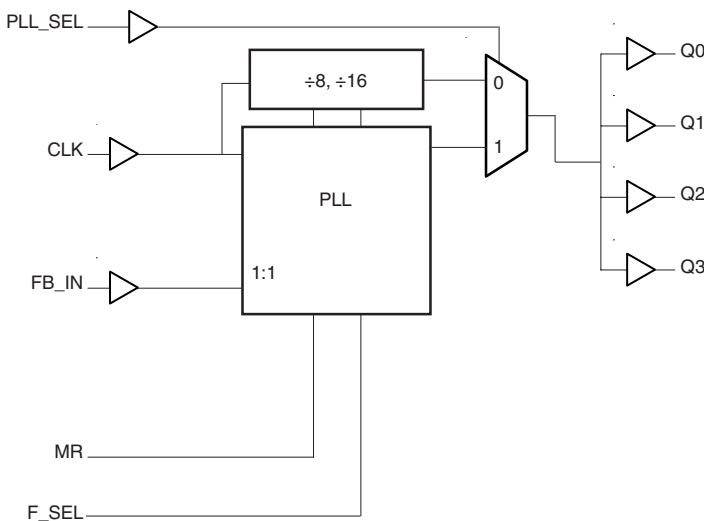

## PIN ASSIGNMENT

Q1	1	16	VDDO
GND	2	15	Q2
Q0	3	14	GND
F_SEL	4	13	Q3
VDD	5	12	VDDO
CLK	6	11	MR
GND	7	10	FB_IN
VDDA	8	9	PLL_SEL

### ICS86004

#### 16-Lead TSSOP

4.4mm x 5.0mm x 0.925mm package body

#### G Package

Top View

**TABLE 1. PIN DESCRIPTIONS**

Number	Name	Type		Description
1, 3, 13, 15	Q1, Q0, Q3, Q2	Output		Clock outputs. 7Ω typical output impedance. LVCMOS/LVTTL interface levels.
2, 7, 14	GND	Power		Power supply ground.
4	F_SEL	Input	Pulldown	Frequency range select input. See Table 3A and 3B. LVCMOS/LVTTL interface levels.
5	V <sub>DD</sub>	Power		Core supply pin.
6	CLK	Input	Pulldown	LVCMOS/LVTTL clock input.
8	V <sub>DDA</sub>	Power		Analog supply pin.
9	PLL_SEL	Input	Pullup	Selects between the PLL and reference clock as input to the dividers. When LOW, selects the reference clock (PLL Bypass). When HIGH, selects PLL (PLL Enabled). LVCMOS/LVTTL interface levels.
10	FB_IN	Input	Pulldown	Feedback input to phase detector for regenerating clocks with "zero delay". Connect to one of the outputs. LVCMOS/LVTTL interface levels.
11	MR	Input	Pulldown	Active HIGH Master Reset. When logic HIGH, the internal dividers are reset causing the outputs to go low. When logic LOW, the internal dividers and the outputs are enabled. LVCMOS/LVTTL interface levels.
12, 16	V <sub>DDO</sub>	Power		Output supply pins.

NOTE: *Pullup* and *Pulldown* refer to internal input resistors. See Table 2, Pin Characteristics, for typical values.

**TABLE 2. PIN CHARACTERISTICS**

Symbol	Parameter	Test Conditions	Minimum	Typical	Maximum	Units
C <sub>IN</sub>	Input Capacitance			4		pF
R <sub>PULLUP</sub>	Input Pullup Resistor			51		kΩ
R <sub>PULLDOWN</sub>	Input Pulldown Resistor			51		kΩ
C <sub>PD</sub>	Power Dissipation Capacitance (per output)	V <sub>DD</sub> , V <sub>DDA</sub> , V <sub>DDO</sub> = 3.465V			23	pF
		V <sub>DD</sub> , V <sub>DDA</sub> , V <sub>DDO</sub> = 2.625V			17	pF
R <sub>OUT</sub>	Output Impedance	3.3V ± 5%	5	7	12	Ω

**TABLE 3A. CONTROL INPUT FUNCTION TABLE, PLL\_SEL = 1**

Input	Input/Output Frequency Range (MHz)	
	Minimum	Maximum
F_SEL = 0	31.25	62.5
F_SEL = 1	15.625	31.25

**TABLE 3B. CONTROL INPUT FUNCTION TABLE, PLL\_SEL = 0**

Input	Output
F_SEL	
0	Ref ÷ 8
1	Ref ÷ 16

## ABSOLUTE MAXIMUM RATINGS

Supply Voltage, $V_{DD}$	4.6V
Inputs, $V_I$	-0.5V to $V_{DD} + 0.5 V$
Outputs, $V_O$	-0.5V to $V_{DDO} + 0.5V$
Package Thermal Impedance, $\theta_{JA}$	89°C/W (0 lfm)
Storage Temperature, $T_{STG}$	-65°C to 150°C

NOTE: Stresses beyond those listed under Absolute Maximum Ratings may cause permanent damage to the device. These ratings are stress specifications only. Functional operation of product at these conditions or any conditions beyond those listed in the *DC Characteristics* or *AC Characteristics* is not implied. Exposure to absolute maximum rating conditions for extended periods may affect product reliability.

**TABLE 4A. POWER SUPPLY DC CHARACTERISTICS,  $V_{DD} = V_{DDA} = V_{DDO} = 3.3V \pm 5\%$ ,  $T_A = 0^\circ C$  TO  $70^\circ C$**

Symbol	Parameter	Test Conditions	Minimum	Typical	Maximum	Units
$V_{DD}$	Core Supply Voltage		3.135	3.3	3.465	V
$V_{DDA}$	Analog Supply Voltage		3.135	3.3	$V_{DD}$	V
$V_{DDO}$	Output Supply Voltage		3.135	3.3	3.465	V
$I_{DD}$	Power Supply Current				98	mA
$I_{DDA}$	Analog Supply Current				17	mA
$I_{DDO}$	Output Supply Current				8	mA

**TABLE 4B. POWER SUPPLY DC CHARACTERISTICS,  $V_{DD} = V_{DDA} = 3.3V \pm 5\%$ ,  $V_{DDO} = 2.5V \pm 5\%$ ,  $T_A = 0^\circ C$  TO  $70^\circ C$**

Symbol	Parameter	Test Conditions	Minimum	Typical	Maximum	Units
$V_{DD}$	Core Supply Voltage		3.135	3.3	3.465	V
$V_{DDA}$	Analog Supply Voltage		3.135	3.3	$V_{DD}$	V
$V_{DDO}$	Output Supply Voltage		2.375	2.5	2.625	V
$I_{DD}$	Power Supply Current				98	mA
$I_{DDA}$	Analog Supply Current				17	mA
$I_{DDO}$	Output Supply Current				8	mA

**TABLE 4C. POWER SUPPLY DC CHARACTERISTICS,  $V_{DD} = V_{DDA} = V_{DDO} = 2.5V \pm 5\%$ ,  $T_A = 0^\circ C$  TO  $70^\circ C$**

Symbol	Parameter	Test Conditions	Minimum	Typical	Maximum	Units
$V_{DD}$	Core Supply Voltage		2.375	2.5	2.625	V
$V_{DDA}$	Analog Supply Voltage		2.375	2.5	$V_{DD}$	V
$V_{DDO}$	Output Supply Voltage		2.375	2.5	2.625	V
$I_{DD}$	Power Supply Current				88	mA
$I_{DDA}$	Analog Supply Current				14	mA
$I_{DDO}$	Output Supply Current				6	mA

**TABLE 4D. LVCMOS / LVTTTL DC CHARACTERISTICS,  $V_{DD} = V_{DDA} = V_{DDO} = 3.3V \pm 5\%$  OR  $2.5V \pm 5\%$ ,  $T_A = 0^\circ C$  TO  $70^\circ C$**

Symbol	Parameter	Test Conditions	Minimum	Typical	Maximum	Units
$V_{IH}$	Input High Voltage	$V_{DD} = 3.3V$	2		$V_{DD} + 0.3$	V
		$V_{DD} = 2.5V$	1.7		$V_{DD} + 0.3$	V
$V_{IL}$	Input Low Voltage	$V_{DD} = 3.3V$	-0.3		0.8	V
		$V_{DD} = 2.5V$	-0.3		0.7	V
$I_{IH}$	Input High Current	CLK, MR, FB_IN, F_SEL $V_{DD} = V_{IN} = 3.465V$			150	$\mu A$
		PLL_SEL $V_{DD} = V_{IN} = 3.465V$			5	$\mu A$
$I_{IL}$	Input Low Current	CLK, MR, FB_IN, F_SEL $V_{DD} = 3.465V, V_{IN} = 0V$	-5			$\mu A$
		PLL_SEL $V_{DD} = 3.465V, V_{IN} = 0V$	-150			$\mu A$
$V_{OH}$	Output High Voltage; NOTE 1	$V_{DDO} = 3.465V$	2.6			V
		$V_{DDO} = 2.625V$	1.8			V
$V_{OL}$	Output Low Voltage; NOTE 1	$V_{DDO} = 3.465V$ or $2.625V$			0.5	V

NOTE 1: Outputs terminated with  $50\Omega$  to  $V_{DDO}/2$ . See Parameter Measurement Information Section, *Output Load Test Circuit Diagrams*.

**TABLE 5A. AC CHARACTERISTICS,  $V_{DD} = V_{DDA} = V_{DDO} = 3.3V \pm 5\%$ ,  $T_A = 0^\circ C$  TO  $70^\circ C$**

Symbol	Parameter	Test Conditions	Minimum	Typical	Maximum	Units
$f_{MAX}$	Output Frequency	F_SEL = 0	31.25		62.5	MHz
		F_SEL = 1	15.625		31.25	MHz
$t_{pLH}$	Propagation Delay, Low-to-High; NOTE 1	PLL_SEL = 0V, Bypass Mode	4.1		6.1	ns
$t(\emptyset)$	Static Phase Offset; NOTE 2, 4	PLL_SEL = 3.3V	-500		500	ps
$t_{sk(o)}$	Output Skew; NOTE 3, 4	PLL_SEL = 0V			65	ps
$f_{jit(cc)}$	Cycle-to-Cycle Jitter; NOTE 4			50	65	ps
$t_L$	PLL Lock Time				1	mS
$t_R / t_F$	Output Rise/Fall Time		0.4		1	ns
odc	Output Duty Cycle		49		51	%

All parameters measured at  $f_{MAX}$  unless noted otherwise.

NOTE 1: Measured from the differential input crossing point to the output at  $V_{DDO}/2$ .

NOTE 2: Defined as the time difference between the input reference clock and the average feedback input signal when the PLL is locked and the input reference frequency is stable.

NOTE 3: Defined as skew between outputs at the same supply voltages and with equal load conditions.

Measured at  $V_{DDO}/2$ .

NOTE 4: This parameter is defined in accordance with JEDEC Standard 65.

**TABLE 5B. AC CHARACTERISTICS,  $V_{DD} = V_{DDA} = 3.3V \pm 5\%$ ,  $V_{DDO} = 2.5V \pm 5\%$ ,  $T_A = 0^\circ\text{C}$  TO  $70^\circ\text{C}$** 

Symbol	Parameter	Test Conditions	Minimum	Typical	Maximum	Units
$f_{MAX}$	Output Frequency	F_SEL = 0	31.25		62.5	MHz
		F_SEL = 1	15.625		31.25	MHz
$t_{pLH}$	Propagation Delay, Low-to-High; NOTE 1	PLL_SEL = 0V, Bypass Mode	4.25		6.25	ns
$t(\emptyset)$	Static Phase Offset; NOTE 2, 4	PLL_SEL = 2.5V	-500		500	ps
$t_{sk(o)}$	Output Skew; NOTE 3, 4	PLL_SEL = 0V			65	ps
$f_{jit(cc)}$	Cycle-to-Cycle Jitter; NOTE 4				65	ps
$t_L$	PLL Lock Time				1	mS
$t_R / t_F$	Output Rise/Fall Time		0.4		1	ns
odc	Output Duty Cycle		48		52	%

All parameters measured at  $f_{MAX}$  unless noted otherwise.

NOTE 1: Measured from the differential input crossing point to the output at  $V_{DDO}/2$ .

NOTE 2: Defined as the time difference between the input reference clock and the average feedback input signal when the PLL is locked and the input reference frequency is stable.

NOTE 3: Defined as skew between outputs at the same supply voltages and with equal load conditions.

Measured at  $V_{DDO}/2$ .

NOTE 4: This parameter is defined in accordance with JEDEC Standard 65.

**TABLE 5C. AC CHARACTERISTICS,  $V_{DD} = V_{DDA} = V_{DDO} = 2.5V \pm 5\%$ ,  $T_A = 0^\circ\text{C}$  TO  $70^\circ\text{C}$** 

Symbol	Parameter	Test Conditions	Minimum	Typical	Maximum	Units
$f_{MAX}$	Output Frequency	F_SEL = 0	31.25		62.5	MHz
		F_SEL = 1	15.625		31.25	MHz
$t_{pLH}$	Propagation Delay, Low-to-High; NOTE 1	PLL_SEL = 0V, Bypass Mode	4.5		6.5	ns
$t(\emptyset)$	Static Phase Offset; NOTE 2, 4	PLL_SEL = 2.5V	-500		500	ps
$t_{sk(o)}$	Output Skew; NOTE 3, 4	PLL_SEL = 0V			65	ps
$f_{jit(cc)}$	Cycle-to-Cycle Jitter; NOTE 4				70	ps
$t_L$	PLL Lock Time				1	mS
$t_R / t_F$	Output Rise/Fall Time		0.4		1	ns
odc	Output Duty Cycle		48		52	%

All parameters measured at  $f_{MAX}$  unless noted otherwise.

NOTE 1: Measured from the differential input crossing point to the output at  $V_{DDO}/2$ .

NOTE 2: Defined as the time difference between the input reference clock and the average feedback input signal when the PLL is locked and the input reference frequency is stable.

NOTE 3: Defined as skew between outputs at the same supply voltages and with equal load conditions.

Measured at  $V_{DDO}/2$ .

NOTE 4: This parameter is defined in accordance with JEDEC Standard 65.

# PARAMETER MEASUREMENT INFORMATION

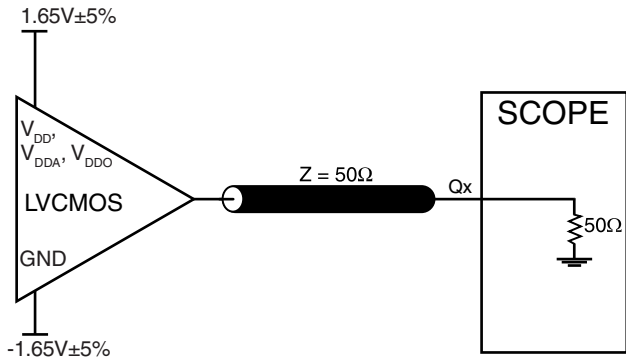

3.3V CORE/3.3V OUTPUT LOAD AC TEST CIRCUIT

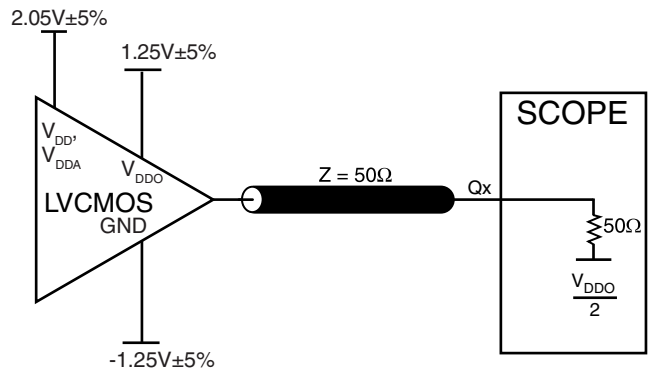

3.3V CORE/2.5V OUTPUT LOAD AC TEST CIRCUIT

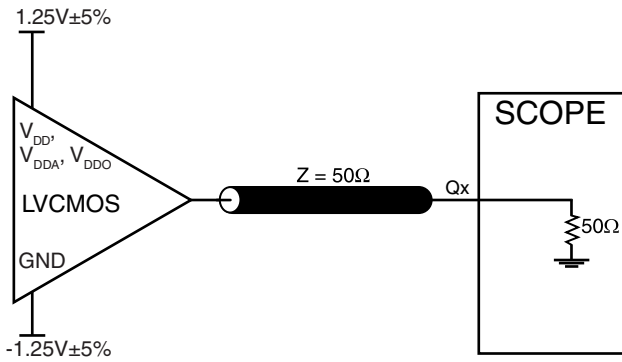

2.5V CORE/ 2.5V OUTPUT LOAD AC TEST CIRCUIT

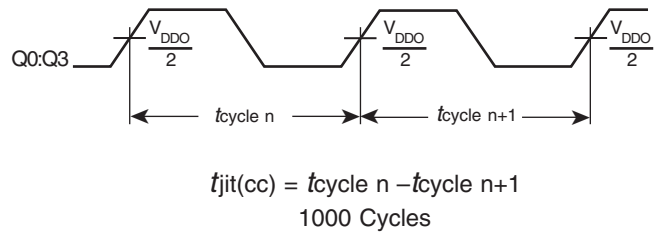

CYCLE-TO-CYCLE JITTER

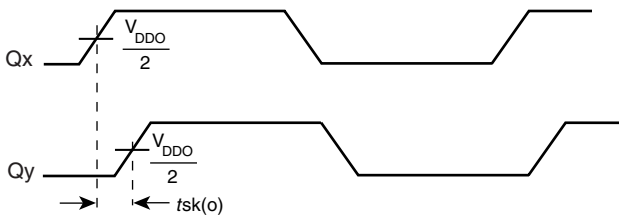

OUTPUT SKEW

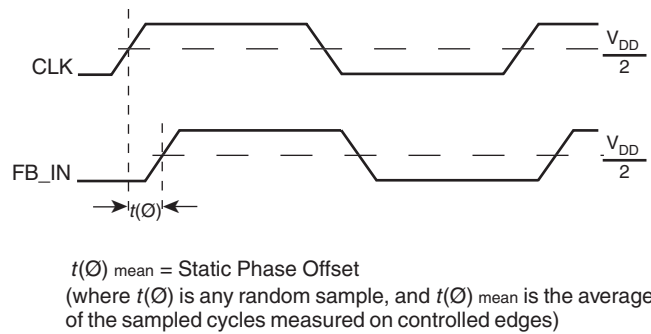

STATIC PHASE OFFSET

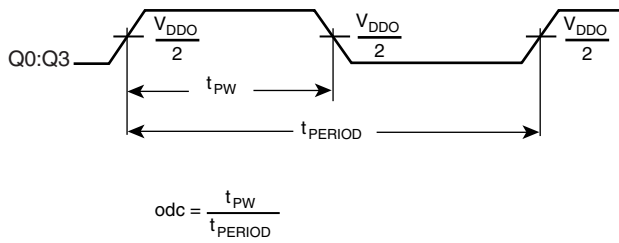

**OUTPUT DUTY CYCLE/PULSE WIDTH/PERIOD**

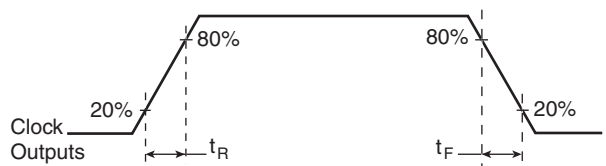

**OUTPUT RISE/FALL TIME**

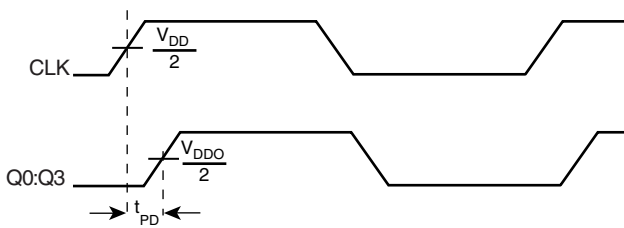

**PROPAGATION DELAY**

# APPLICATION INFORMATION

## POWER SUPPLY FILTERING TECHNIQUES

As in any high speed analog circuitry, the power supply pins are vulnerable to random noise. The ICS86004 provides separate power supplies to isolate any high switching noise from the outputs to the internal PLL.  $V_{DD}$ ,  $V_{DDA}$ , and  $V_{DDO}$  should be individually connected to the power supply plane through vias, and bypass capacitors should be used for each pin. To achieve optimum jitter performance, power supply isolation is required. *Figure 1* illustrates how a  $10\Omega$  resistor along with a  $10\mu\text{F}$  and a  $.01\mu\text{F}$  bypass capacitor should be connected to each  $V_{DDA}$ .

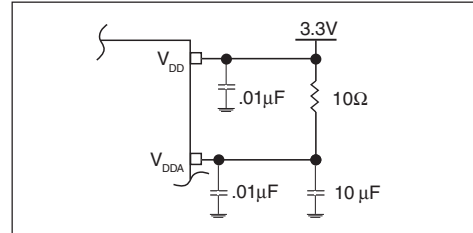

FIGURE 1. POWER SUPPLY FILTERING

## RECOMMENDATIONS FOR UNUSED INPUT AND OUTPUT PINS

### INPUTS:

#### LVC MOS CONTROL PINS:

All control pins have internal pull-ups or pull-downs; additional resistance is not required but can be added for additional protection. A  $1\text{k}\Omega$  resistor can be used.

### OUTPUTS:

#### LVC MOS OUTPUT:

All unused LVC MOS output can be left floating. We recommend that there is no trace attached.

## SCHEMATIC EXAMPLE

*Figure 2* shows a schematic example of using an ICS86004. It is recommended to have one decouple capacitor per power pin. Each decoupling capacitor should be located as close as possible

to the power pin. The low pass filter R7, C11 and C16 for clean analog supply should also be located as close to the  $V_{DDA}$  pin as possible.

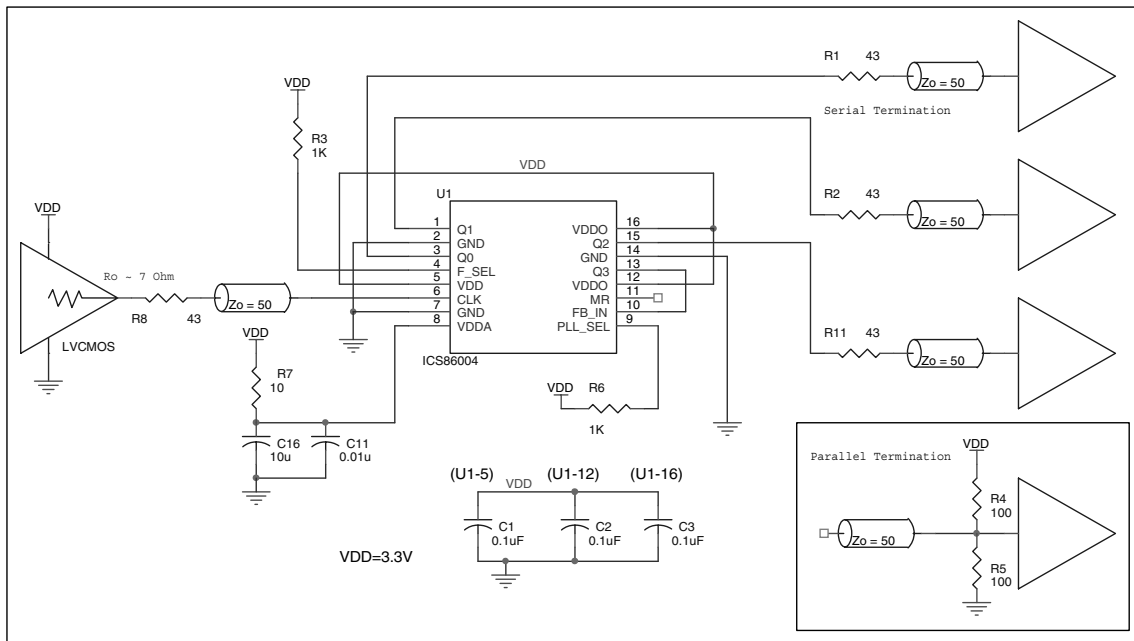

FIGURE 2. ICS86004 SCHEMATIC EXAMPLE

# RELIABILITY INFORMATION

TABLE 5.  $\theta_{JA}$  vs. AIR FLOW TABLE FOR 16 LEAD TSSOP

$\theta_{JA}$ by Velocity (Linear Feet per Minute)			
	0	200	500
Single-Layer PCB, JEDEC Standard Test Boards	137.1°C/W	118.2°C/W	106.8°C/W
Multi-Layer PCB, JEDEC Standard Test Boards	89.0°C/W	81.8°C/W	78.1°C/W

**NOTE:** Most modern PCB designs use multi-layered boards. The data in the second row pertains to most designs.

## TRANSISTOR COUNT

The transistor count for ICS86004 is: 2496

PACKAGE OUTLINE - G SUFFIX 16 LEAD TSSOP

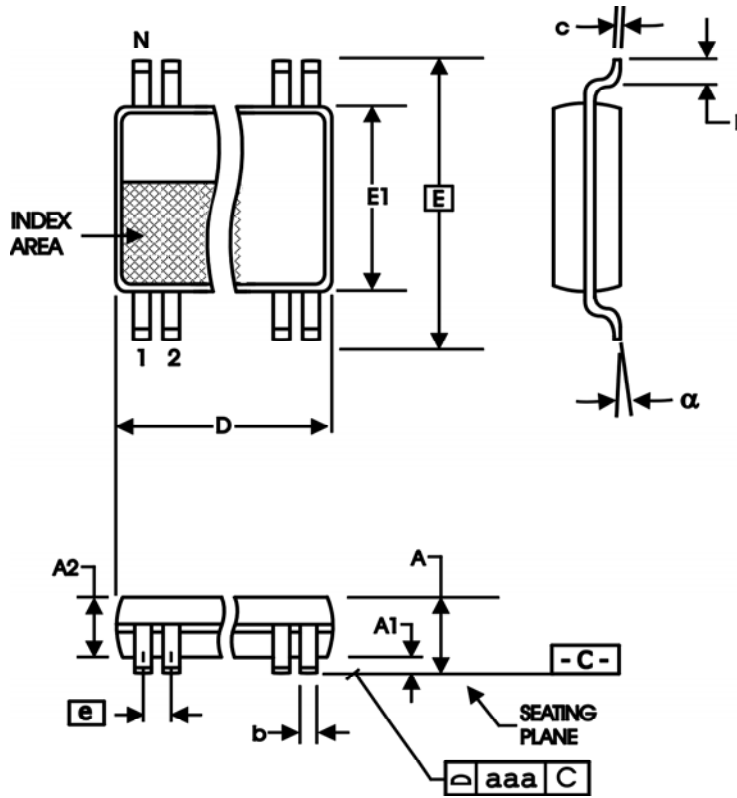

TABLE 6. PACKAGE DIMENSIONS

SYMBOL	Millimeters	
	Minimum	Maximum
N	16	
A	--	1.20
A1	0.05	0.15
A2	0.80	1.05
b	0.19	0.30
c	0.09	0.20
D	4.90	5.10
E	6.40 BASIC	
E1	4.30	4.50
e	0.65 BASIC	
L	0.45	0.75
$\alpha$	0°	8°
aaa	--	0.10

Reference Document: JEDEC Publication 95, MO-153

**TABLE 7. ORDERING INFORMATION**

<b>Part/Order Number</b>	<b>Marking</b>	<b>Package</b>	<b>Shipping Packaging</b>	<b>Temperature</b>
ICS86004BG	86004BG	16 Lead TSSOP	Tube	0°C to 70°C
ICS86004BGT	86004BG	16 Lead TSSOP	2500 Tape & Reel	0°C to 70°C
ICS86004BGLF	86004BGL	16 Lead "Lead-Free" TSSOP	Tube	0°C to 70°C
ICS86004BGLFT	86004BGL	16 Lead "Lead-Free" TSSOP	2500 Tape & Reel	0°C to 70°C

NOTE: Parts that are ordered with an "LF" suffix to the part number are the Pb-Free configuration and are RoHS compliant.

The ICS logo is a registered trademark, and HiPerClockS is a trademark of Integrated Circuit Systems, Inc. All other trademarks are the property of their respective owners and may be registered in certain jurisdictions.

While the information presented herein has been checked for both accuracy and reliability, Integrated Circuit Systems, Incorporated (ICS) assumes no responsibility for either its use or for infringement of any patents or other rights of third parties, which would result from its use. No other circuits, patents, or licenses are implied. This product is intended for use in normal commercial applications. Any other applications such as those requiring extended temperature range, high reliability, or other extraordinary environmental requirements are not recommended without additional processing by ICS. ICS reserves the right to change any circuitry or specifications without notice. ICS does not authorize or warrant any ICS product for use in life support devices or critical medical instruments.

**REVISION HISTORY SHEET**

<b>Rev</b>	<b>Table</b>	<b>Page</b>	<b>Description of Change</b>	<b>Date</b>
A	T7	1	Pin Assignment - corrected package body dimensions from 4.4mm x 3.0 mm x 0.92mm to 4.4mm x 5.0 mm x 0.925mm.	3/31/06
		12	Ordering Information Table - corrected marking from ICS86004BG from 86004BG. Added lead-free marking.	
B	4A	3	3.3V Power Supply Table - changed $V_{DDA}$ max from 3.465V to $V_{DD}$ , changed $I_{DDO}$ from 79mA max. to 8mA max.	6/21/06
	4B	3	3.3V/2.5V Power Supply Table - changed $V_{DDA}$ max from 3.465V to $V_{DD}$ , changed $I_{DDO}$ from 79mA max. to 8mA max.	
	4C	3	2.5V Power Supply Table - changed $V_{DDA}$ max from 3.465V to $V_{DD}$ , changed $I_{DDO}$ from 79mA max. to 6mA max.	

**Innovate with IDT and accelerate your future networks. Contact:**

**www.IDT.com**

**For Sales**

800-345-7015  
408-284-8200  
Fax: 408-284-2775

**For Tech Support**

netcom@idt.com  
480-763-2056

---

**Corporate Headquarters**

Integrated Device Technology, Inc.  
6024 Silver Creek Valley Road  
San Jose, CA 95138  
United States  
800 345 7015  
+408 284 8200 (outside U.S.)

**Asia Pacific and Japan**

Integrated Device Technology  
Singapore (1997) Pte. Ltd.  
Reg. No. 199707558G  
435 Orchard Road  
#20-03 Wisma Atria  
Singapore 238877  
+65 6 887 5505

**Europe**

IDT Europe, Limited  
321 Kingston Road  
Leatherhead, Surrey  
KT22 7TU  
England  
+44 (0) 1372 363 339  
Fax: +44 (0) 1372 378851



www.IDT.com