



FEMTOCLOCKS– CRYSTAL-TO-LVDS FREQUENCY SYNTHESIZER

ICS844002I-01

General Description



The ICS844002I-01 is a 2 output LVDS Synthesizer optimized to generate Ethernet reference clock frequencies and is a member of the HiPerClocks™ family of high performance clock solutions from IDT. Using a 25MHz, 18pF parallel resonant crystal, the following frequencies can be generated based on the 2 frequency select pins (F_SEL[1:0]): 156.25MHz, 125MHz and 62.5MHz. The ICS844002I-01 uses IDT's 3rd generation low phase noise VCO technology and can achieve <1ps typical rms phase jitter, easily meeting Ethernet jitter requirements. The ICS844002I-01 is packaged in a small 20-pin TSSOP package.

Features

- Two differential LVDS outputs
- Selectable crystal oscillator interface or single-ended LVCMOS/LVTTL input
- Supports the following output frequencies: 156.25MHz, 125MHz, 62.5MHz
- VCO range: 560MHz – 680MHz
- RMS phase jitter @ 156.25MHz, using a 25MHz crystal (1.875MHz – 20MHz): 0.41ps (typical)
- Full 2.5V supply mode
- -40°C to 85°C ambient operating temperature
- Available in both standard (RoHS 5) and lead-free (RoHS 6) packages

Block Diagram

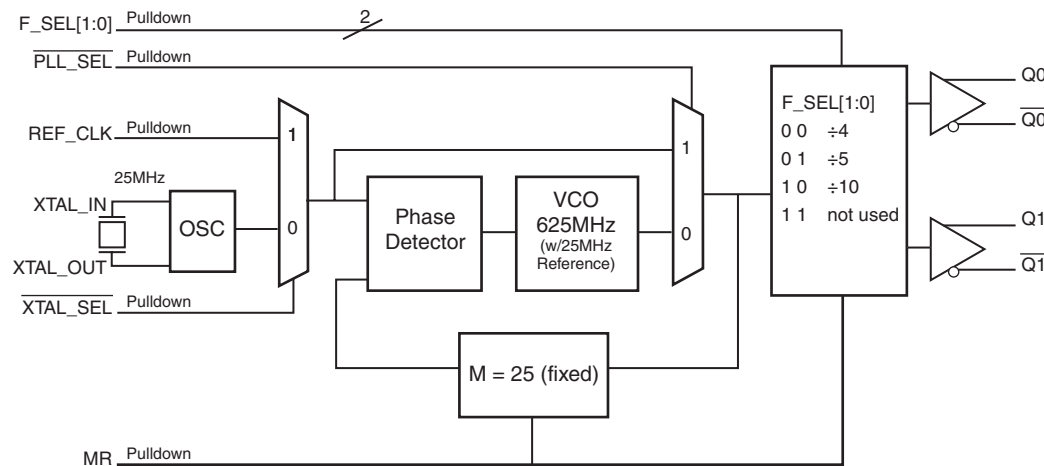

Pin Assignment

nc	1	20	VDDO
VDDO	2	19	Q1
Q0	3	18	Q1-bar
Q0-bar	4	17	GND
MR	5	16	nc
PLL_SEL	6	15	XTAL_SEL
nc	7	14	REF_CLK
VDDA	8	13	XTAL_IN
F_SEL0	9	12	XTAL_OUT
VDD	10	11	F_SEL1

ICS844002I-01
20-Lead TSSOP
6.5mm x 4.4mm x 0.925mm
package body
G Package
Top View

Table 1. Pin Descriptions

Number	Name	Type		Description
1, 7	nc	Unused		No connect.
2, 20	V _{DDO}	Power		Output supply pins.
3, 4	Q0, Q0	Output		Differential output pair. LVDS interface levels.
5	MR	Input	Pulldown	Active HIGH Master Reset. When logic HIGH, the internal dividers are reset causing the true outputs Qx to go low and the inverted outputs Qx to go high. When logic LOW, the internal dividers and the outputs are enabled. LVCMOS/LVTTL interface levels.
6	PLL_SEL	Input	Pulldown	Selects between the PLL and REF_CLK as input to the dividers. When LOW, selects PLL (PLL Enable). When HIGH, deselects the reference clock (PLL Bypass). LVCMOS/LVTTL interface levels.
8	V _{DDA}	Power		Analog supply pin.
9, 11	FSEL0, F_SEL1	Input	Pulldown	Frequency select pins. LVCMOS/LVTTL interface levels.
10	V _{DD}	Power		Core supply pins.
12, 13	XTAL_OUT, XTAL_IN	Input		Parallel resonant crystal interface. XTAL_OUT is the output, XTAL_IN is the input.
14	REF_CLK	Input	Pulldown	Non-inverting differential clock input.
15	XTAL_SEL	Input	Pulldown	Selects between crystal or REF_CLK inputs as the PLL Reference source. Selects XTAL inputs when LOW. Selects REF_CLK when HIGH. LVCMOS/LVTTL interface levels.
16	nc	Unused		No connect.
17	GND	Power		Power supply ground.
18, 19	Q1, Q1	Output		Differential output pair. LVDS interface levels.

NOTE: *Pulldown* refers to internal input resistors. See Table 2, *Pin Characteristics*, for typical values.

Table 2. Pin Characteristics

Symbol	Parameter	Test Conditions	Minimum	Typical	Maximum	Units
C _{IN}	Input Capacitance			4		pF
R _{PULLDOWN}	Input Pulldown Resistor			51		kΩ

Absolute Maximum Ratings

NOTE: Stresses beyond those listed under *Absolute Maximum Ratings* may cause permanent damage to the device. These ratings are stress specifications only. Functional operation of product at these conditions or any conditions beyond those listed in the *DC Characteristics* or *AC Characteristics* is not implied. Exposure to absolute maximum rating conditions for extended periods may affect product reliability.

Item	Rating
Supply Voltage, V_{DD}	4.6V
Inputs, V_I	-0.5V to $V_{DD} + 0.5V$
Outputs, I_O Continuous Current Surge Current	10mA 15mA
Package Thermal Impedance, θ_{JA}	73.2°C/W (0 lfp/m)
Storage Temperature, T_{STG}	-65°C to 150°C

DC Electrical Characteristics

Table 3A. Power Supply DC Characteristics, $V_{DD} = V_{DDA} = V_{DDO} = 2.5V \pm 5\%$, $T_A = -40^\circ C$ to $85^\circ C$

Symbol	Parameter	Test Conditions	Minimum	Typical	Maximum	Units
V_{DD}	Core Supply Voltage		2.375	2.5	2.625	V
V_{DDA}	Analog Supply Voltage		2.375	2.5	2.625	V
V_{DDO}	Output Supply Voltage		2.375	2.5	2.625	V
I_{DD}	Power Supply Current				98	mA
I_{DDA}	Analog Supply Current				12	mA
I_{DDO}	Output Supply Current				98	mA

Table 3B. LVCMOS/LVTTL DC Characteristics, $V_{DD} = V_{DDA} = V_{DDO} = 2.5V \pm 5\%$, $T_A = -40^\circ C$ to $85^\circ C$

Symbol	Parameter	Test Conditions	Minimum	Typical	Maximum	Units
V_{IH}	Input High Voltage	2.5V	1.7		$V_{DD} + 0.3$	V
V_{IL}	Input Low Voltage	2.5V	-0.3		0.7	V
I_{IH}	Input High Current	REF_CLK, MR, FSEL0, FSEL1, PLL_SEL, XTAL_SEL $V_{DD} = V_{IN} = 2.625V$			150	μA
I_{IL}	Input Low Current	REF_CLK, MR, FSEL0, FSEL1, PLL_SEL, XTAL_SEL $V_{DD} = 2.625V, V_{IN} = 0V$	-5			μA

Table 3C. LVDS DC Characteristics, $V_{DD} = V_{DDA} = V_{DDO} = 2.5V \pm 5\%$, $T_A = -40^{\circ}C$ to $85^{\circ}C$

Symbol	Parameter	Test Conditions	Minimum	Typical	Maximum	Units
V_{OD}	Differential Output Voltage		240		550	mV
ΔV_{OD}	V_{OD} Magnitude Change			40		mV
V_{OS}	Offset Voltage		0.7	1.1	1.5	V
ΔV_{OS}	V_{OS} Magnitude Change			50		mV

Table 4. Crystal Characteristics

Parameter	Test Conditions	Minimum	Typical	Maximum	Units
Mode of Oscillation		Fundamental			
Frequency		22.4	25	27.2	MHz
Equivalent Series Resistance (ESR)				50	Ω
Shunt Capacitance				7	pF
Drive Level				1	mW

AC Electrical Characteristics

Table 5. AC Characteristics, $V_{DD} = V_{DDA} = V_{DDO} = 2.5V \pm 5\%$, $T_A = -40^{\circ}C$ to $85^{\circ}C$

Symbol	Parameter	Test Conditions	Minimum	Typical	Maximum	Units
f_{OUT}	Output Frequency	FSEL[1:0] = 00	140		170	MHz
		FSEL[1:0] = 01	112		136	MHz
		FSEL[1:0] = 10	56		68	MHz
$t_{sk(o)}$	Output Skew; NOTE 1, 2		5	20	ps	
$f_{jit}(\emptyset)$	RMS Phase Jitter, (Random); NOTE 3	156.25MHz, (1.875MHz – 20MHz)		0.41		ps
		125MHz, (1.875MHz – 20MHz)		0.44		ps
		62.5MHz, (1.875MHz – 20MHz)		0.47		ps
t_R / t_F	Output Rise/Fall Time	20% to 80%	250		550	ps
odc	Output Duty Cycle		48		52	%
t_L	PLL Lock Time				100	ms

NOTE: Electrical parameters are guaranteed over the specified ambient operating temperature range, which is established when device is mounted in a test socket with maintained transverse airflow greater than 500 lpm. Device will meet specifications after thermal equilibrium has been reached under these conditions.

NOTE 1: Defined as skew between outputs at the same supply voltages and with equal load conditions. Measured at $V_{DDO}/2$.

NOTE 2: This parameter is defined in accordance with JEDEC Standard 65.

NOTE 3: Please refer to the Phase Noise Plot.

Typical Phase Noise at 156.25MHz

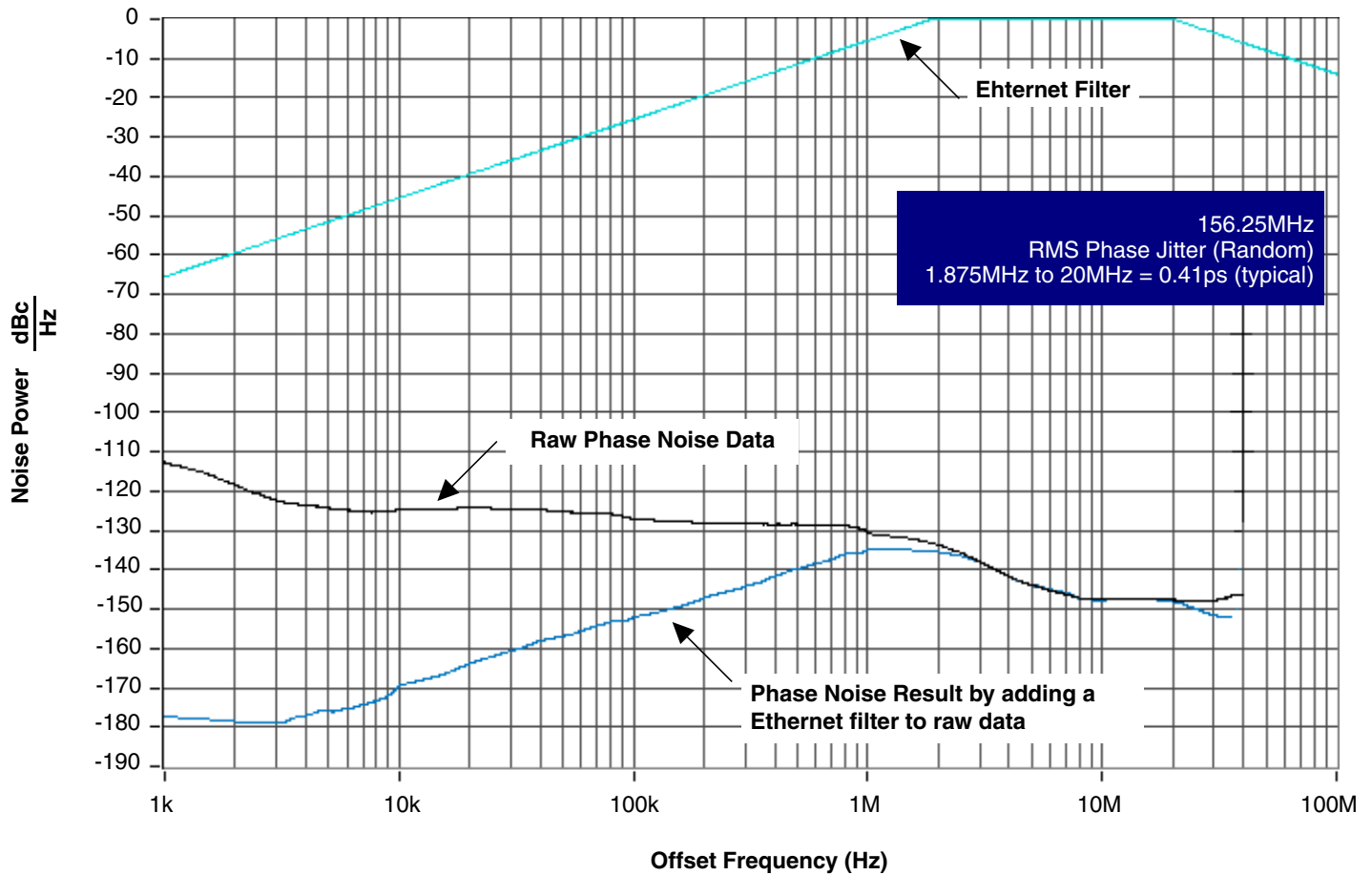

Parameter Measurement Information

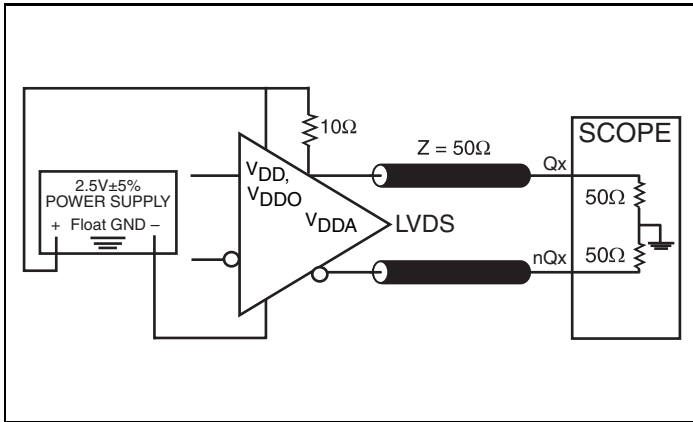

2.5V Output Load AC Test Circuit

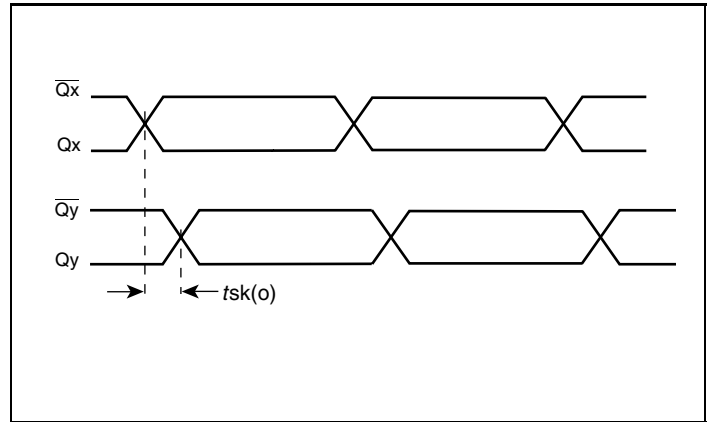

Output Skew

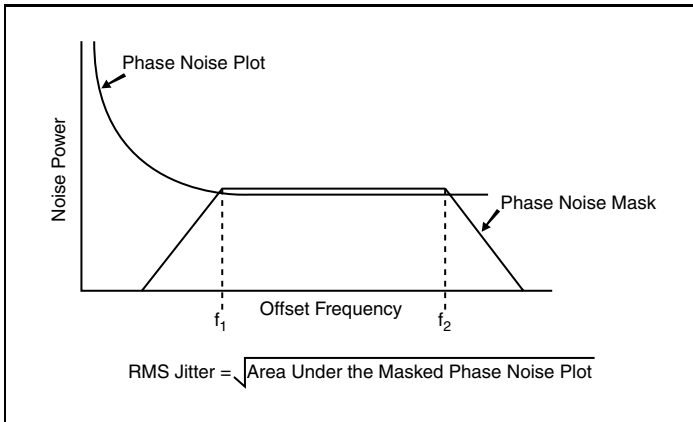

RMS Phase Jitter

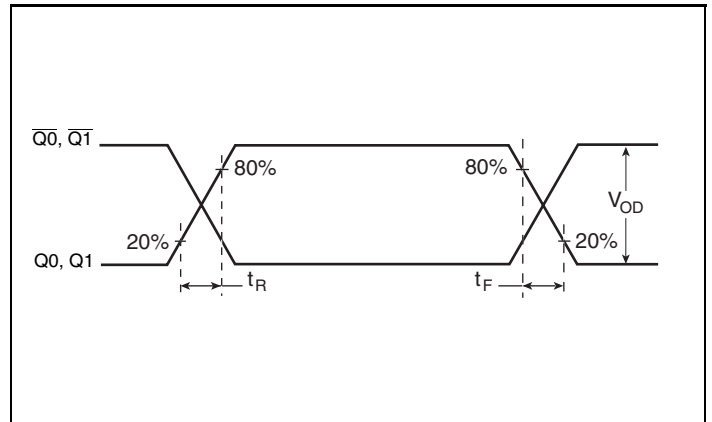

Output Rise/Fall Time

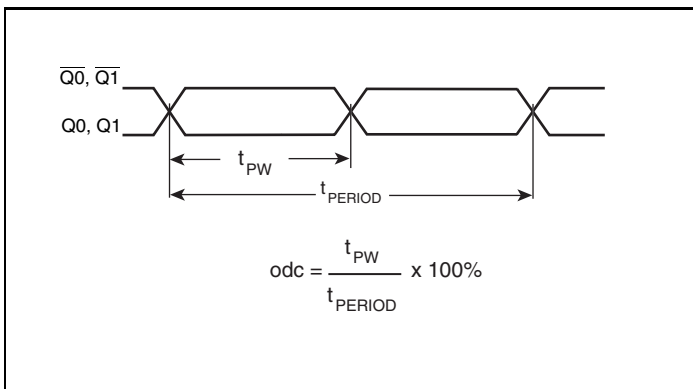

Output Duty Cycle/Pulse Width/Period

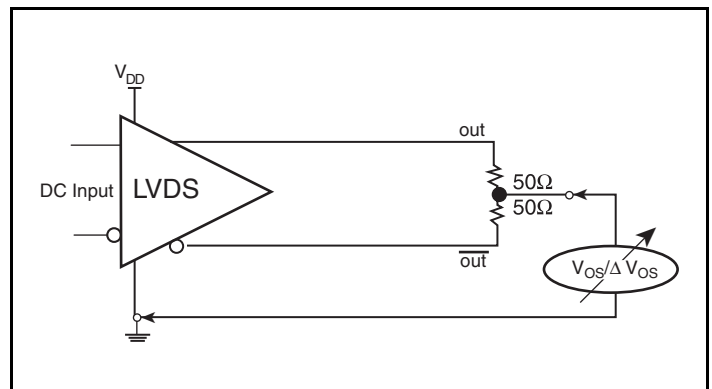

Offset Voltage Setup

Parameter Measurement Information, continued

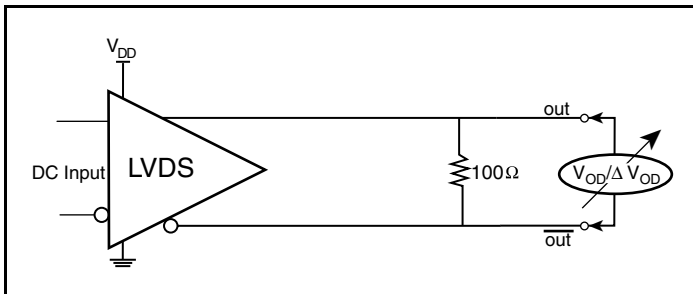

Differential Offset Voltage Setup

Application Information

Power Supply Filtering Technique

As in any high speed analog circuitry, the power supply pins are vulnerable to random noise. To achieve optimum jitter performance, power supply isolation is required. The ICS844002I-01 provides separate power supplies to isolate any high switching noise from the outputs to the internal PLL. V_{DD} , V_{DDA} and V_{DDO} should be individually connected to the power supply plane through vias, and $0.01\mu\text{F}$ bypass capacitors should be used for each pin. *Figure 1* illustrates this for a generic V_{DD} pin and also shows that V_{DDA} requires that an additional 10Ω resistor along with a $10\mu\text{F}$ bypass capacitor be connected to the V_{DDA} pin.

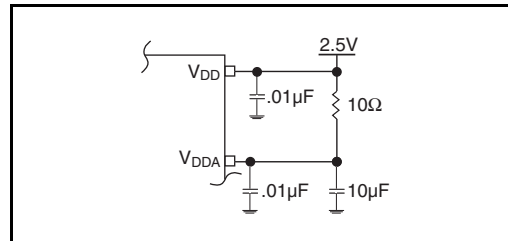

Figure 1. Power Supply Filtering

Recommendations for Unused Input and Output Pins

Inputs:

LVCMOS Control Pins

All control pins have internal pulldowns; additional resistance is not required but can be added for additional protection. A $1\text{k}\Omega$ resistor can be used.

REF_CLK Input

For applications not requiring the use of the reference clock, it can be left floating. Though not required, but for additional protection, a $1\text{k}\Omega$ resistor can be tied from the REF_CLK to ground.

Crystal Inputs

For applications not requiring the use of the crystal oscillator input, both XTAL_IN and XTAL_OUT can be left floating. Though not required, but for additional protection, a $1\text{k}\Omega$ resistor can be tied from XTAL_IN to ground.

Outputs:

LVDS Outputs

All unused LVDS output pairs can be either left floating or terminated with 100Ω across. If they are left floating, we recommend that there is no trace attached.

Crystal Input Interface

The ICS844002I-01 has been characterized with 18pF parallel resonant crystals. The capacitor values shown in *Figure 2* below

were determined using a 25MHz, 18pF parallel resonant crystal and were chosen to minimize the ppm error.

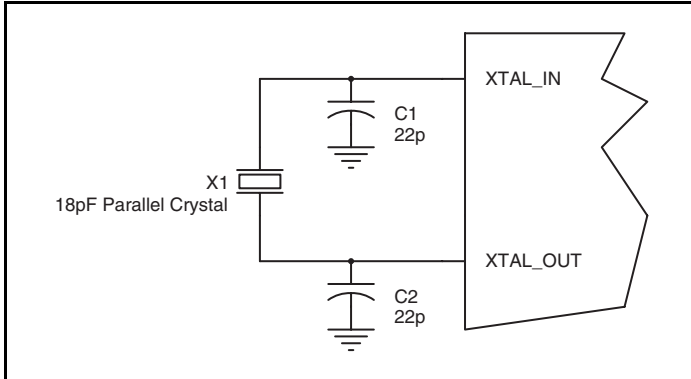

Figure 2. Crystal Input Interface

LVC MOS to XTAL Interface

The XTAL_IN input can accept a single-ended LVC MOS signal through an AC coupling capacitor. A general interface diagram is shown in *Figure 3*. The XTAL_OUT pin can be left floating. The input edge rate can be as slow as 10ns. For LVC MOS inputs, it is recommended that the amplitude be reduced from full swing to half swing in order to prevent signal interference with the power rail and to reduce noise. This configuration requires that the output

impedance of the driver (R_o) plus the series resistance (R_s) equals the transmission line impedance. In addition, matched termination at the crystal input will attenuate the signal in half. This can be done in one of two ways. First, R_1 and R_2 in parallel should equal the transmission line impedance. For most 50 Ω applications, R_1 and R_2 can be 100 Ω . This can also be accomplished by removing R_1 and making R_2 50 Ω .

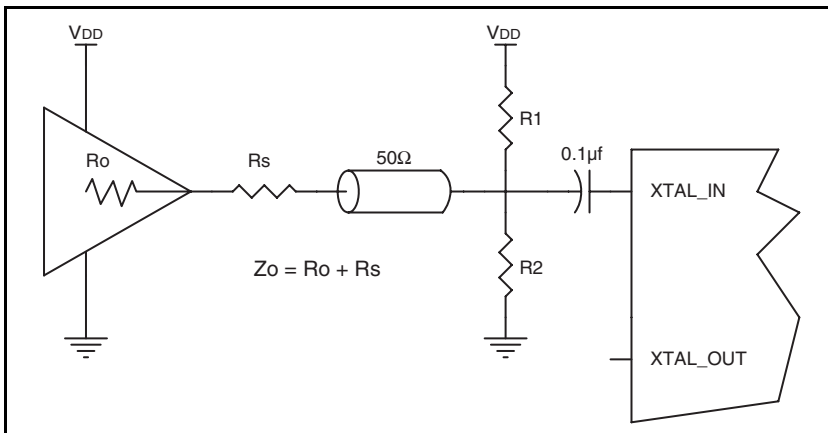

Figure 3. General Diagram for LVC MOS Driver to XTAL Input Interface

2.5V LVDS Driver Termination

Figure 4 shows a typical termination for LVDS driver in characteristic impedance of 100Ω differential (50Ω single)

transmission line environment. For buffer with multiple LVDS driver, it is recommended to terminate the unused outputs.

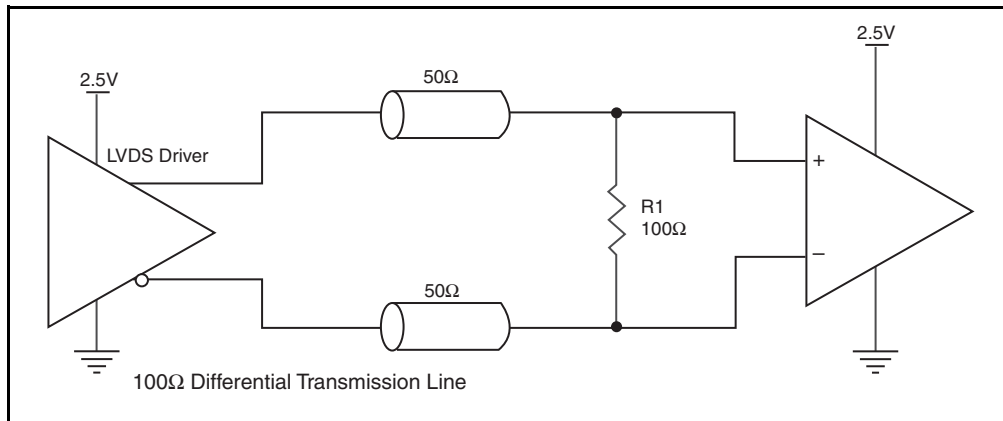

Figure 4. Typical LVDS Driver Termination

Power Considerations

This section provides information on power dissipation and junction temperature for the ICS844002I-01. Equations and example calculations are also provided.

1. Power Dissipation.

The total power dissipation for the ICS844002I-01 is the sum of the core power plus the analog power plus the power dissipated in the load(s). The following is the power dissipation for $V_{DD} = 2.5V + 5\% = 2.625V$, which gives worst case results.

- Power (core)_{MAX} = $V_{DD_MAX} * (I_{DD_MAX} + I_{DDA_MAX}) = 2.625V * (98mA + 12mA) = \mathbf{288.75mW}$
- Power (outputs)_{MAX} = $V_{DDO_MAX} * I_{DDO_MAX} = 2.625V * 98mA = \mathbf{257.25mW}$

$$\mathbf{Total\ Power_{MAX} = 288.75mW + 257.25mW = 546mW}$$

2. Junction Temperature.

Junction temperature, T_j , is the temperature at the junction of the bond wire and bond pad and directly affects the reliability of the device. The maximum recommended junction temperature for HiPerClockS devices is 125°C.

The equation for T_j is as follows: $T_j = \theta_{JA} * Pd_total + T_A$

T_j = Junction Temperature

θ_{JA} = Junction-to-Ambient Thermal Resistance

Pd_total = Total Device Power Dissipation (example calculation is in section 1 above)

T_A = Ambient Temperature

In order to calculate junction temperature, the appropriate junction-to-ambient thermal resistance θ_{JA} must be used. Assuming a moderate air flow of 200 linear feet per minute and a multi-layer board, the appropriate value is 66.6°C/W per Table 6 below.

Therefore, T_j for an ambient temperature of 85°C with all outputs switching is:

$$85^\circ\text{C} + 0.546\text{W} * 66.6^\circ\text{C/W} = 121.4^\circ\text{C}. \text{ This is below the limit of } 125^\circ\text{C}.$$

This calculation is only an example. T_j will obviously vary depending on the number of loaded outputs, supply voltage, air flow and the type of board (single layer or multi-layer).

Table 6. Thermal Resistance θ_{JA} for 20 Lead TSSOP, Forced Convection

Linear Feet per Minute	θ_{JA} by Velocity		
	0	200	500
Single-Layer PCB, JEDEC Standard Test Boards	114.5°C/W	98.0°C/W	88.0°C/W
Multi-Layer PCB, JEDEC Standard Test Boards	73.2°C/W	66.6°C/W	63.5°C/W

Reliability Information

Table 7. θ_{JA} vs. Air Flow Table for a 20 Lead TSSOP

Linear Feet per Minute	θ_{JA} by Velocity		
	0	200	500
Single-Layer PCB, JEDEC Standard Test Boards	114.5°C/W	98.0°C/W	88.0°C/W
Multi-Layer PCB, JEDEC Standard Test Boards	73.2°C/W	66.6°C/W	63.5°C/W

Transistor Count

The transistor count for ICS844002I-01 is: 2914

Package Outline and Package Dimensions

Package Outline - G Suffix for 20 Lead TSSOP

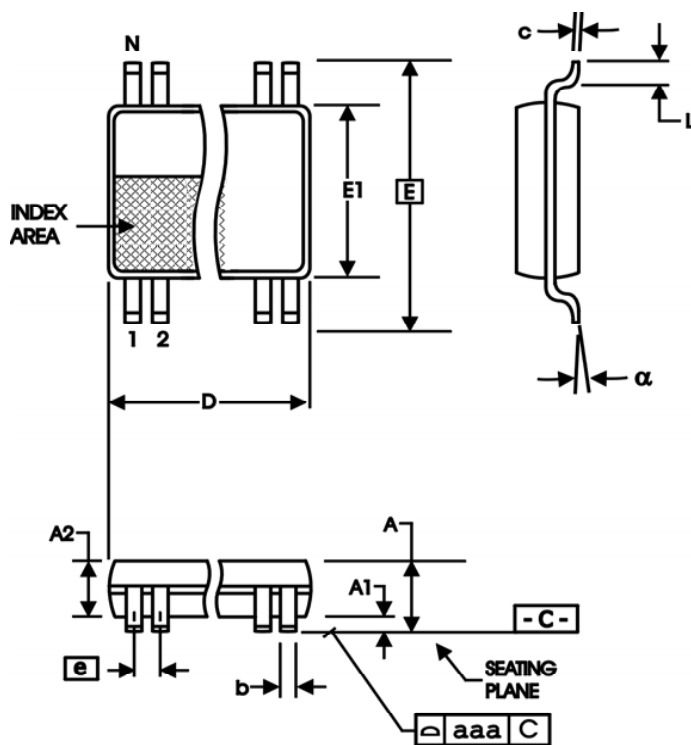

Table 8. Package Dimensions

All Dimensions in Millimeters		
Symbol	Minimum	Maximum
N	20	
A		1.20
A1	0.05	0.15
A2	0.80	1.05
b	0.19	0.30
c	0.09	0.20
D	6.40	6.60
E	6.40 Basic	
E1	4.30	4.50
e	0.65 Basic	
L	0.45	0.75
α	0°	8°
aaa		0.10

Reference Document: JEDEC Publication 95, MO-153

Ordering Information

Table 9. Ordering Information

Part/Order Number	Marking	Package	Shipping Packaging	Temperature
844002AGI-01	ICS44002AI01	20 Lead TSSOP	Tube	-40°C to 85°C
844002AGI-01T	ICS44002AI01	20 Lead TSSOP	2500 Tape & Reel	-40°C to 85°C
844002AGI-01LF	ICS4002AI01L	"Lead-Free" 20 Lead TSSOP	Tube	-40°C to 85°C
844002AGI-01LFT	ICS4002AI01L	"Lead-Free" 20 Lead TSSOP	2500 Tape & Reel	-40°C to 85°C

NOTE: Parts that are ordered with an "LF" suffix to the part number are the Pb-Free configuration and are RoHS compliant.

While the information presented herein has been checked for both accuracy and reliability, Integrated Device Technology (IDT) assumes no responsibility for either its use or for the infringement of any patents or other rights of third parties, which would result from its use. No other circuits, patents, or licenses are implied. This product is intended for use in normal commercial and industrial applications. Any other applications, such as those requiring high reliability or other extraordinary environmental requirements are not recommended without additional processing by IDT. IDT reserves the right to change any circuitry or specifications without notice. IDT does not authorize or warrant any IDT product for use in life support devices or critical medical instruments.

Revision History Sheet

Rev	Table	Page	Description of Change	Date
C	T1 T3B	1	Pin Assignment - correct pin 16 from V_{DD} to nc.	9/28/07
		2	Pin Description Table - deleted pin 16 from V_{DD} row. Added Pin 16 row, "nc".	
		3	LVC MOS DC Characteristics Table - corrected I_{IL} from -150 μ A min. to -5 μ A min.	
		7	Parameter Measurement Information - corrected Output Rise/Fall Time diagram.	
		10	Power Considerations - updated calculations.	
D	T5	4	AC Characteristics Table - added PLL Lock Time.	10/20/08
		6	Parameter Measurement Information - deleted 3.3V Output Load AC Test Circuit and added RMS Phase Jitter diagram.	

Contact Information:

www.IDT.com

Sales

800-345-7015 (inside USA)
+408-284-8200 (outside USA)
Fax: 408-284-2775
www.IDT.com/go/contactIDT

Technical Support

netcom@idt.com
+480-763-2056

Corporate Headquarters

Integrated Device Technology, Inc.
6024 Silver Creek Valley Road
San Jose, CA 95138
United States
800-345-7015 (inside USA)
+408-284-8200 (outside USA)