



# FEMTOCLOCK™ CRYSTAL-TO-3.3V LVPECL FREQUENCY SYNTHESIZER

**ICS843252**

## General Description



The ICS843252 is a 2 differential output LVPECL Synthesizer designed to generate Ethernet reference clock frequencies and is a member of the HiPerClocks™ family of high performance clock solutions from IDT. Using a 25MHz, 18pF parallel resonant crystal, the following frequencies can be generated based on the settings of 4 frequency select pins (SELA[1:0], SELB[1:0]): 625MHz, 312.5MHz, 156.25MHz, and 125MHz.

The two banks have their own dedicated frequency select pins and can be independently set for the frequencies mentioned above. The ICS843252 IDT's 3<sup>rd</sup> generation low phase noise VCO technology and can achieve 1ps or lower typical rms phase jitter, easily meeting Ethernet jitter requirements. The ICS843252 is packaged in a small 16-pin TSSOP package.

## Features

- Two differential LVPECL output pairs
- Using a 25MHz crystal, the two output banks can be independently set for 625MHz, 312.5MHz, 156.25MHz or 125MHz
- Crystal oscillator interface
- VCO frequency: 490MHz – 680MHz
- RMS Phase Jitter @ 156.25MHz, (1.875MHz – 20MHz) using a 25MHz crystal: 0.47ps (typical)
- Full 3.3V supply mode
- 0°C to 70°C ambient operating temperature
- Industrial temperature available upon request
- Available in both standard (RoHS 5) and lead-free (RoHS 6) packages

## Block Diagram

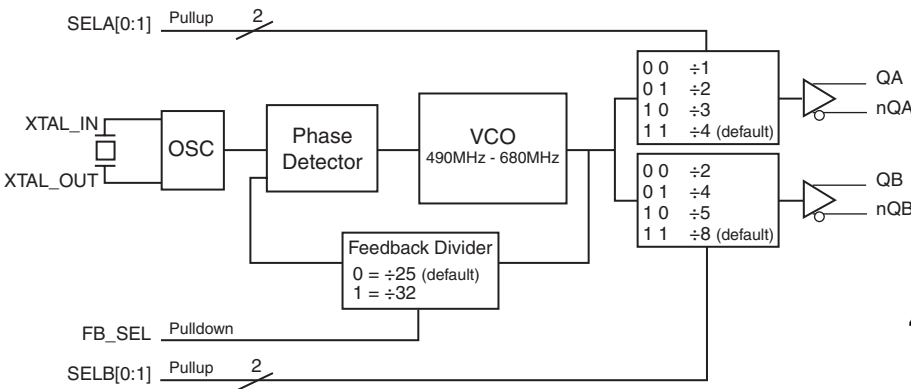

## Pin Assignment

nQB	1	16	XTAL_IN
QB	2	15	XTAL_OUT
Vcc <sub>B</sub>	3	14	VEE
SELB1	4	13	SELA1
SELB0	5	12	SELA0
Vcc <sub>A</sub>	6	11	Vcc
QA	7	10	VCCA
nQA	8	9	FB_SEL

**ICS843252**

**16-Lead TSSOP**

**4.4mm x 5.0mm x 0.925mm package body  
G Package**

**Table 1. Pin Descriptions**

Number	Name	Type		Description
1, 2	nQB, QB	Output		Bank B differential output pair. LVPECL interface levels.
3	V <sub>CCO_B</sub>	Power		Output supply pin for QB/nQB outputs.
4, 5	SELB1, SELB0	Input	Pullup	Division select pins for Bank B. LVCMOS/LVTTL interface levels.
6	V <sub>CCO_A</sub>	Power		Output supply pin for QA/nQA outputs.
7, 8	QA, nQA	Output		Bank A differential output pair. LVPECL interface levels.
9	FB_SEL	Input	Pulldown	Feedback divide select. When LOW, the feedback divider is set for ÷25. When HIGH, the feedback divider is set for ÷32. LVCMOS/LVTTL interface levels.
10	V <sub>CCA</sub>	Power		Analog supply pin.
11	V <sub>CC</sub>	Power		Core supply pin.
12, 13	SELA0, SELA1	Input	Pullup	Division select pins for Bank A. LVCMOS/LVTTL interface levels.
14	V <sub>EE</sub>	Power		Negative supply pin.
15, 16	XTAL_OUT XTAL_IN	Input		Crystal oscillator interface XTAL_IN is the input, XTAL_OUT is the output.

NOTE: *Pullup and Pulldown* refer to internal input resistors. See Table 2, *Pin Characteristics*, for typical values.

**Table 2. Pin Characteristics**

Symbol	Parameter	Test Conditions	Minimum	Typical	Maximum	Units
C <sub>IN</sub>	Input Capacitance			4		pF
R <sub>PULLUP</sub>	Input Pullup Resistor			51		kΩ
R <sub>PULLDOWN</sub>	Input Pulldown Resistor			51		kΩ

## Function Tables

Table 3A. Bank A Frequency Table

Inputs				Feedback Divider	Bank A Output Divider	M/N Multiplication Factor	QA, nQA Output Frequency (MHz)
Crystal Frequency (MHz)	FB_SEL	SELA1	SELA0				
25	0	0	0	25	1	25	625
25	0	0	1	25	2	12.5	312.5
20	0	0	1	25	2	12.5	250
22.5	0	1	0	25	3	8.333	187.5
25	0	1	1	25	4	6.25	156.25
24	0	1	1	25	4	6.25	150
20	0	1	1	25	4	6.25	125
19.44	1	0	0	32	1	32	622.08
19.44	1	0	1	32	2	16	311.04
15.625	1	0	1	32	2	16	250
18.75	1	1	0	32	3	10.667	200
19.44	1	1	1	32	4	8	155.52
18.75	1	1	1	32	4	8	150
15.625	1	1	1	32	4	8	125

Table 3B. Bank B Frequency Table

Inputs				Feedback Divider	Bank B Output Divider	M/N Multiplication Factor	QB, nQB Output Frequency (MHz)
Crystal Frequency (MHz)	FB_SEL	SELB1	SELB0				
25	0	0	0	25	2	12.5	312.5
20	0	0	0	25	2	12.5	250
25	0	0	1	25	4	6.25	156.25
24	0	0	1	25	4	6.25	150
20	0	0	1	25	4	6.25	125
25	0	1	0	25	5	5	125
25	0	1	1	25	8	3.125	78.125
24	0	1	1	25	8	3.125	75
20	0	1	1	25	8	3.125	62.5
19.44	1	0	0	32	2	16	311.04
15.625	1	0	0	32	2	16	250
19.44	1	0	1	32	4	8	155.52
18.75	1	0	1	32	4	8	150
15.625	1	0	1	32	4	8	125
15.625	1	1	0	32	5	6.4	100
19.44	1	1	1	32	8	4	77.76
18.75	1	1	1	32	8	4	75
15.625	1	1	1	32	8	4	62.5

Table 3C. Output Bank A Configuration Select Function Table

Inputs		Outputs
SELA1	SELA0	QA, nQA
0	0	÷1
0	1	÷2
1	0	÷3
1	1	÷4 (default)

Table 3D. Output Bank B Configuration Select Function Table

Inputs		Outputs
SELB1	SELB0	QB, nQB
0	0	÷2
0	1	÷4
1	0	÷5
1	1	÷8 (default)

Table 3E. Feedback Divider Configuration Select Function Table

Input	
FB_SEL	Feedback Divide
0	÷25 (default)
1	÷32

## Absolute Maximum Ratings

NOTE: Stresses beyond those listed under *Absolute Maximum Ratings* may cause permanent damage to the device. These ratings are stress specifications only. Functional operation of product at these conditions or any conditions beyond those listed in the *DC Characteristics* or *AC Characteristics* is not implied. Exposure to absolute maximum rating conditions for extended periods may affect product reliability.

Item	Rating
Supply Voltage, $V_{CC}$	4.6V
Inputs, $V_I$	-0.5V to $V_{CC} + 0.5V$
Outputs, $I_O$ Continuous Current Surge Current	50mA 100mA
Package Thermal Impedance, $\theta_{JA}$	92.4°C/W (0 mps)
Storage Temperature, $T_{STG}$	-65°C to 150°C

## DC Electrical Characteristics

**Table 4A. Power Supply DC Characteristics,  $V_{CC} = V_{CCO\_A} = V_{CCO\_B} = 3.3V \pm 5\%$ ,  $V_{EE} = 0V$ ,  $T_A = 0^\circ C$  to  $70^\circ C$**

Symbol	Parameter	Test Conditions	Minimum	Typical	Maximum	Units
$V_{CC}$	Core Supply Voltage		3.135	3.3	3.465	V
$V_{CCA}$	Analog Supply Voltage		$V_{CC} - 0.10$	3.3	$V_{CC}$	V
$V_{CCO\_A}$ , $V_{CCO\_B}$	Power Supply Voltage		3.135	3.3	3.465	V
$I_{CCA}$	Analog Supply Current				10	mA
$I_{EE}$	Power Supply Current				145	mA

**Table 4B. LVCMOS/LVTTL DC Characteristics,  $V_{CC} = V_{CCO\_A} = V_{CCO\_B} = 3.3V \pm 5\%$ ,  $V_{EE} = 0V$ ,  $T_A = 0^\circ C$  to  $70^\circ C$**

Symbol	Parameter	Test Conditions	Minimum	Typical	Maximum	Units
$V_{IH}$	Input High Voltage		2		$V_{CC} + 0.3$	V
$V_{IL}$	Input Low Voltage		-0.3		0.8	V
$I_{IH}$	Input High Current	FB_SEL	$V_{CC} = V_{IN} = 3.465V$		150	$\mu A$
		SELA[1:0], SELB[1:0]	$V_{CC} = V_{IN} = 3.465V$		5	$\mu A$
$I_{IL}$	Input Low Current	FB_SEL	$V_{CC} = 3.465V$ , $V_{IN} = 0V$	-5		$\mu A$
		SELA[1:0], SELB[1:0]	$V_{CC} = 3.465V$ , $V_{IN} = 0V$	-150		$\mu A$

**Table 4C. LVPECL DC Characteristics,  $V_{CC} = V_{CCO\_A} = V_{CCO\_B} = 3.3V \pm 5\%$ ,  $V_{EE} = 0V$ ,  $T_A = 0^\circ C$  to  $70^\circ C$** 

Symbol	Parameter	Test Conditions	Minimum	Typical	Maximum	Units
$V_{OH}$	Output High Voltage; NOTE 1		$V_{CCO\_X} - 1.4$		$V_{CCO\_X} - 0.9$	V
$V_{OL}$	Output Low Voltage; NOTE 1		$V_{CCO\_X} - 2.0$		$V_{CCO\_X} - 1.7$	V
$V_{SWING}$	Peak-to-Peak Output Voltage Swing		0.6		1.0	V

NOTE 1: Output termination with  $50\Omega$  to  $V_{CCO\_A, \_B} - 2V$ .

**Table 5. Crystal Characteristics**

Parameter	Test Conditions	Minimum	Typical	Maximum	Units
Mode of Oscillation		Fundamental			
Frequency	FB_SEL = $\div 25$	19.6		27.2	MHz
	FB_SEL = $\div 32$	15.313		21.25	MHz
Equivalent Series Resistance (ESR)				50	$\Omega$
Shunt Capacitance				7	pF
Drive Level				1	mW

NOTE: Characterized using an 18pF parallel resonant crystal.

## AC Electrical Characteristics

**Table 6. AC Characteristics,  $V_{CC} = V_{CCO\_A} = V_{CCO\_B} = 3.3V \pm 5\%$ ,  $V_{EE} = 0V$ ,  $T_A = 0^\circ C$  to  $70^\circ C$** 

Parameter	Symbol	Test Conditions	Minimum	Typical	Maximum	Units
$f_{OUT}$	Output Frequency Range	Output Divider = $\div 1$	490		680	MHz
		Output Divider = $\div 2$	245		340	MHz
		Output Divider = $\div 3$	163.33		226.67	MHz
		Output Divider = $\div 4$	122.5		170	MHz
		Output Divider = $\div 5$	98		136	MHz
		Output Divider = $\div 8$	61.25		85	MHz
$t_{sk(o)}$	Output Skew; NOTE 1, 2	Outputs @ Same Frequency			80	ps
		Outputs @ Different Frequencies			190	ps
$f_{jit}(\emptyset)$	RMS Phase Jitter, (Random); NOTE 3	625MHz, (1.875MHz – 20MHz)		0.36		ps
		312.5MHz, (1.875MHz – 20MHz)		0.43		ps
		156.25MHz, (1.875MHz – 20MHz)		0.47		ps
		125MHz, (1.875MHz – 20MHz)		0.47		ps
$t_R / t_F$	Output Rise/Fall Time	20% to 80%	300		700	ps
odc	Output Duty Cycle		47		53	%

NOTE: Electrical parameters are guaranteed over the specified ambient operating temperature range, which is established when the device is mounted in a test socket with maintained transverse airflow greater than 500 lfpm. The device will meet specifications after thermal equilibrium has been reached under these conditions.

NOTE 1: Defined as skew between outputs at the same supply voltages and with equal load conditions. Measured at the output differential cross points.

NOTE 2: This parameter is defined in accordance with JEDEC Standard 65.

NOTE 3: Please refer to the Phase Noise Plots.

## Typical Phase Noise at 625MHz

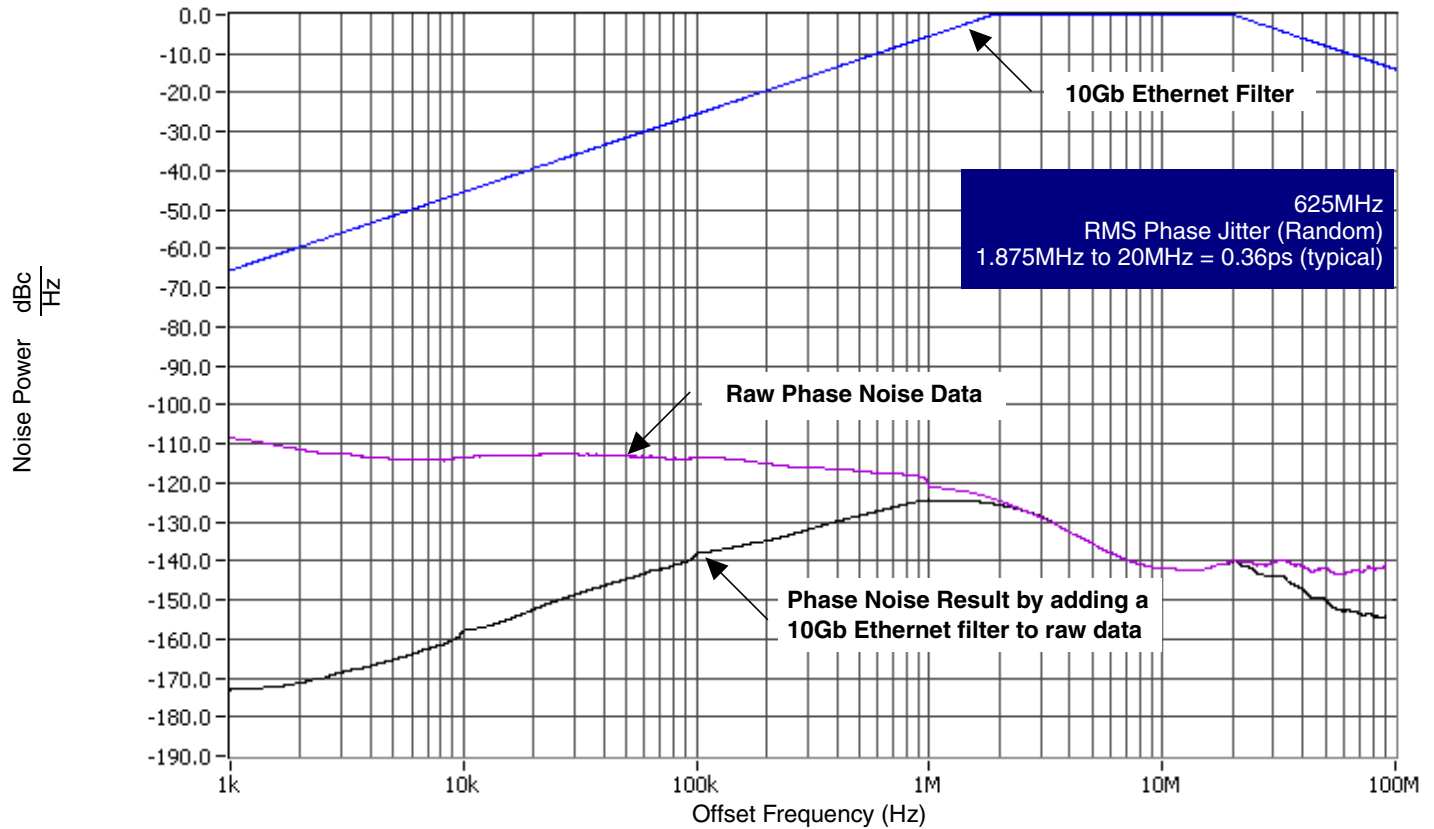

## Typical Phase Noise at 156.25MHz

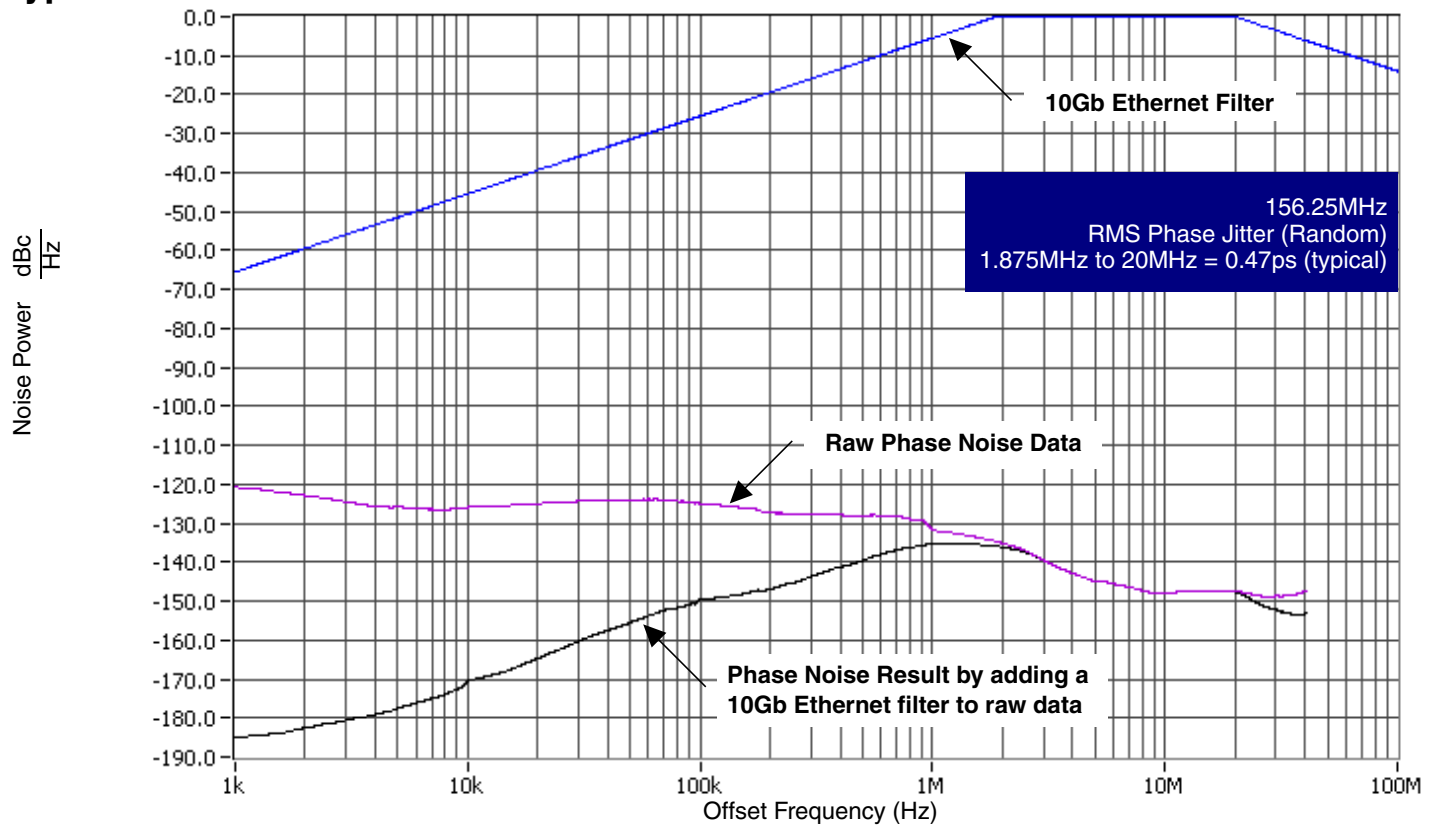

### Parameter Measurement Information

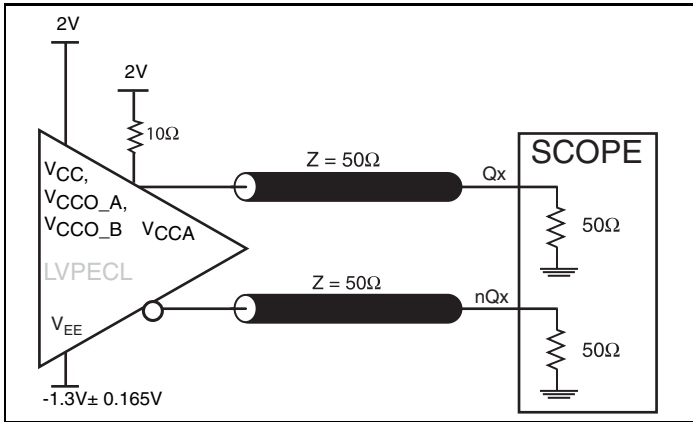

3.3V LVPECL Output Load AC Test Circuit

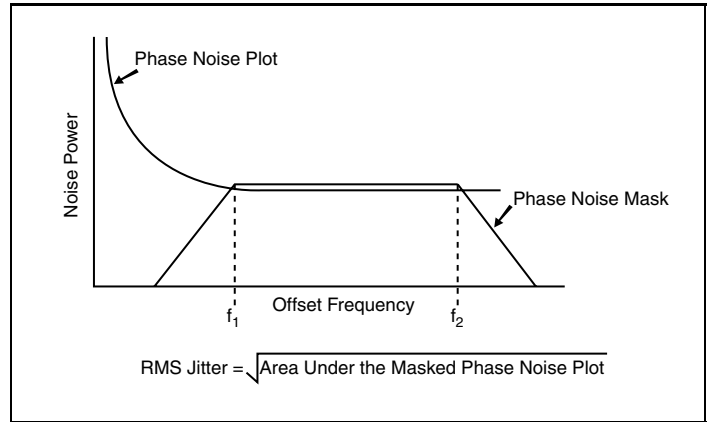

RMS Phase Jitter

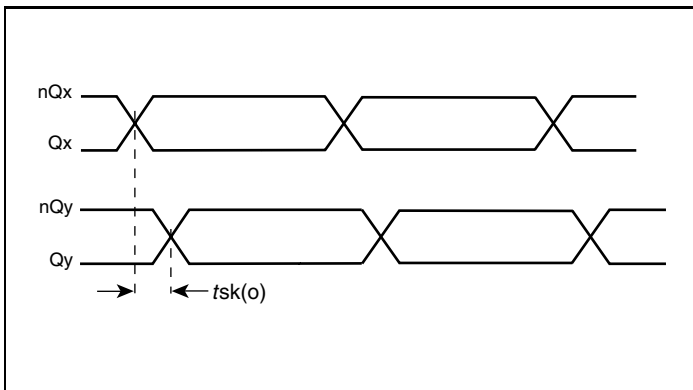

Output Skew

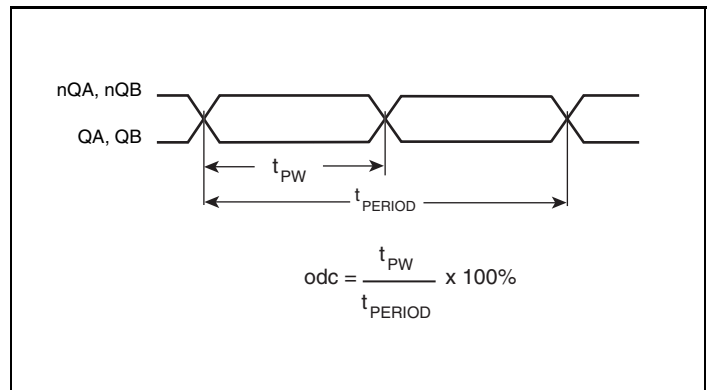

Output Duty Cycle/Pulse Width/Period

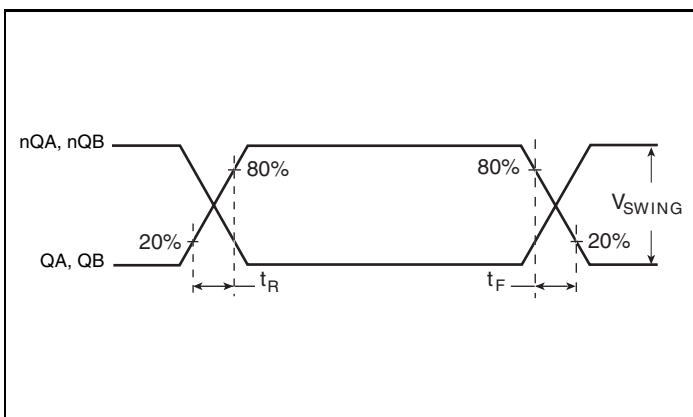

Output Rise/Fall Time

## Application Information

### Recommendations for Unused Input Pins

#### Inputs:

##### LVC MOS Control Pins

All control pins have internal pullups and pulldowns; additional resistance is not required but can be added for additional protection. A 1k $\Omega$  resistor can be used.

### Power Supply Filtering Technique

As in any high speed analog circuitry, the power supply pins are vulnerable to random noise. To achieve optimum jitter performance, power supply isolation is required. The ICS843252 provides separate power supplies to isolate any high switching noise from the outputs to the internal PLL.  $V_{CC}$ ,  $V_{CCA}$ ,  $V_{CCO\_A}$ , and  $V_{CCO\_B}$  should be individually connected to the power supply plane through vias, and 0.01 $\mu$ F bypass capacitors should be used for each pin. *Figure 1* illustrates this for a generic  $V_{DD}$  pin and also shows that  $V_{CCA}$  requires that an additional 10 $\Omega$  resistor along with a 10 $\mu$ F bypass capacitor be connected to the  $V_{CCA}$  pin.

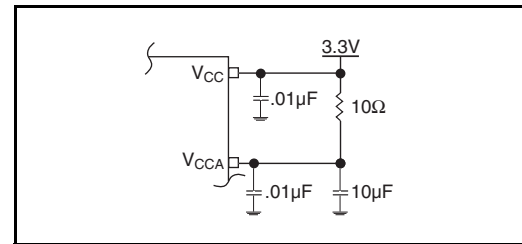

**Figure 1. Power Supply Filtering**

### Crystal Input Interface

The ICS843252 has been characterized with 18pF parallel resonant crystals. The capacitor values, C1 and C2, shown in

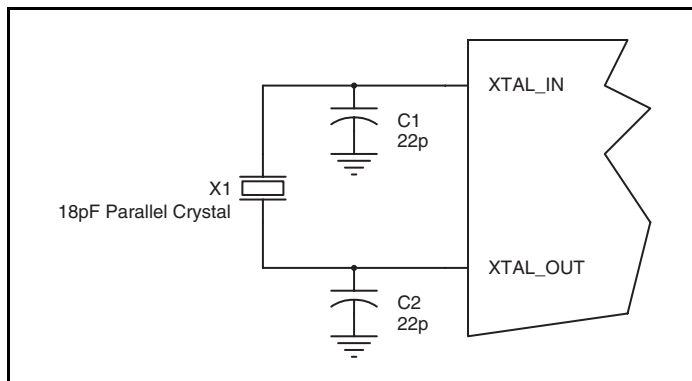

**Figure 2. Crystal Input Interface**

#### Outputs:

##### LVPECL Outputs

All unused LVPECL outputs can be left floating. We recommend that there is no trace attached. Both sides of the differential output pair should either be left floating or terminated.

*Figure 2* below were determined using a 25MHz, 18pF parallel resonant crystal and were chosen to minimize the ppm error.

## LVC MOS to XTAL Interface

The XTAL\_IN input can accept a single-ended LVC MOS signal through an AC coupling capacitor. A general interface diagram is shown in *Figure 3*. The XTAL\_OUT pin can be left floating. The input edge rate can be as slow as 10ns. For LVC MOS inputs, it is recommended that the amplitude be reduced from full swing to half swing in order to prevent signal interference with the power rail and to reduce noise. This configuration requires that the output

impedance of the driver ( $R_o$ ) plus the series resistance ( $R_s$ ) equals the transmission line impedance. In addition, matched termination at the crystal input will attenuate the signal in half. This can be done in one of two ways. First,  $R_1$  and  $R_2$  in parallel should equal the transmission line impedance. For most 50Ω applications,  $R_1$  and  $R_2$  can be 100Ω. This can also be accomplished by removing  $R_1$  and making  $R_2$  50Ω.

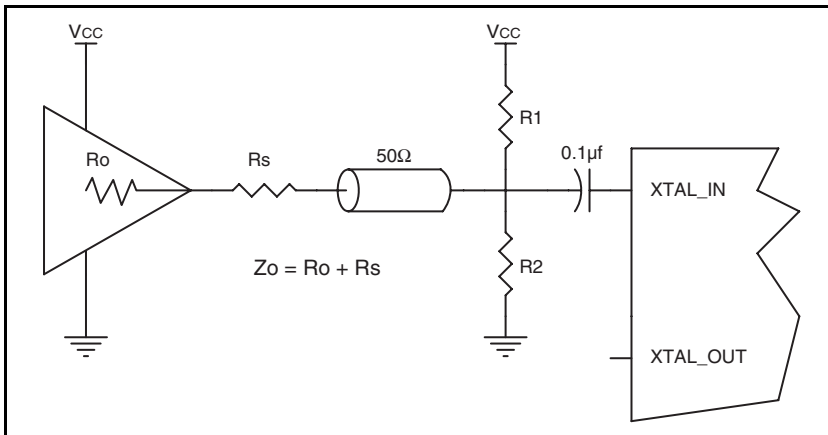

Figure 3. General Diagram for LVC MOS Driver to XTAL Input Interface

## Termination for 3.3V LVPECL Outputs

The clock layout topology shown below is a typical termination for LVPECL outputs. The two different layouts mentioned are recommended only as guidelines.

FOUT and nFOUT are low impedance follower outputs that generate ECL/LVPECL compatible outputs. Therefore, terminating resistors (DC current path to ground) or current sources must be used for functionality. These outputs are designed to drive 50Ω

transmission lines. Matched impedance techniques should be used to maximize operating frequency and minimize signal distortion. *Figures 4A and 4B* show two different layouts which are recommended only as guidelines. Other suitable clock layouts may exist and it would be recommended that the board designers simulate to guarantee compatibility across all printed circuit and clock component process variations.

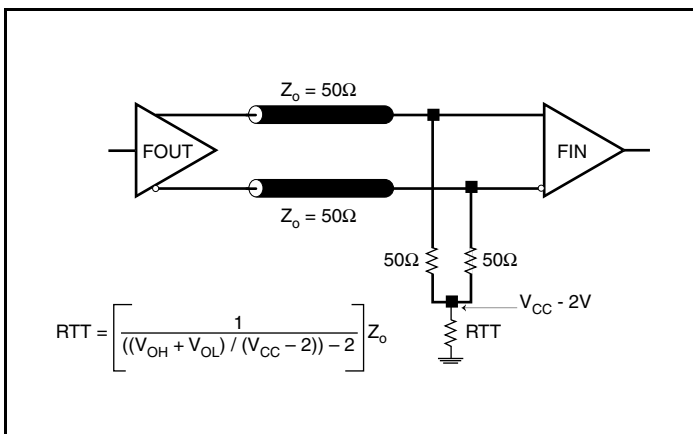

Figure 4A. 3.3V LVPECL Output Termination

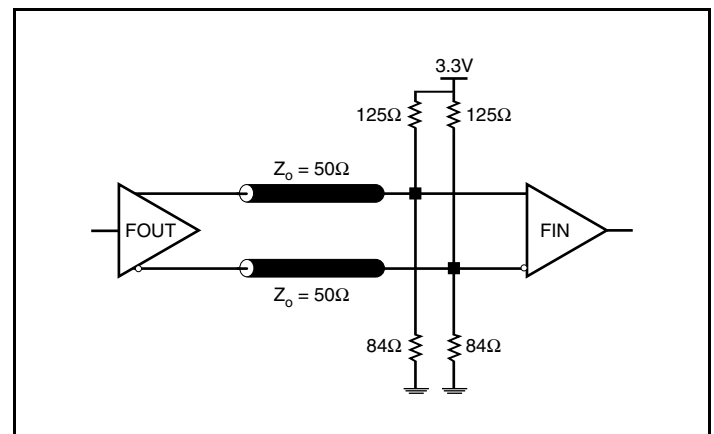

Figure 4B. 3.3V LVPECL Output Termination

## Schematic Example

Figure 5 shows an example of ICS843252 application schematic. In this example, the device is operated at  $V_{CC} = 3.3V$ . The 18pF parallel resonant 25MHz crystal is used. The  $C1 = 22pF$  and  $C2 = 22pF$  are recommended for frequency accuracy. For different board layouts, the  $C1$  and  $C2$  may be slightly adjusted for

optimizing frequency accuracy. Two examples of LVPECL terminations are shown in this schematic. Additional termination approaches are shown in the *LVPECL Termination Application Note*.

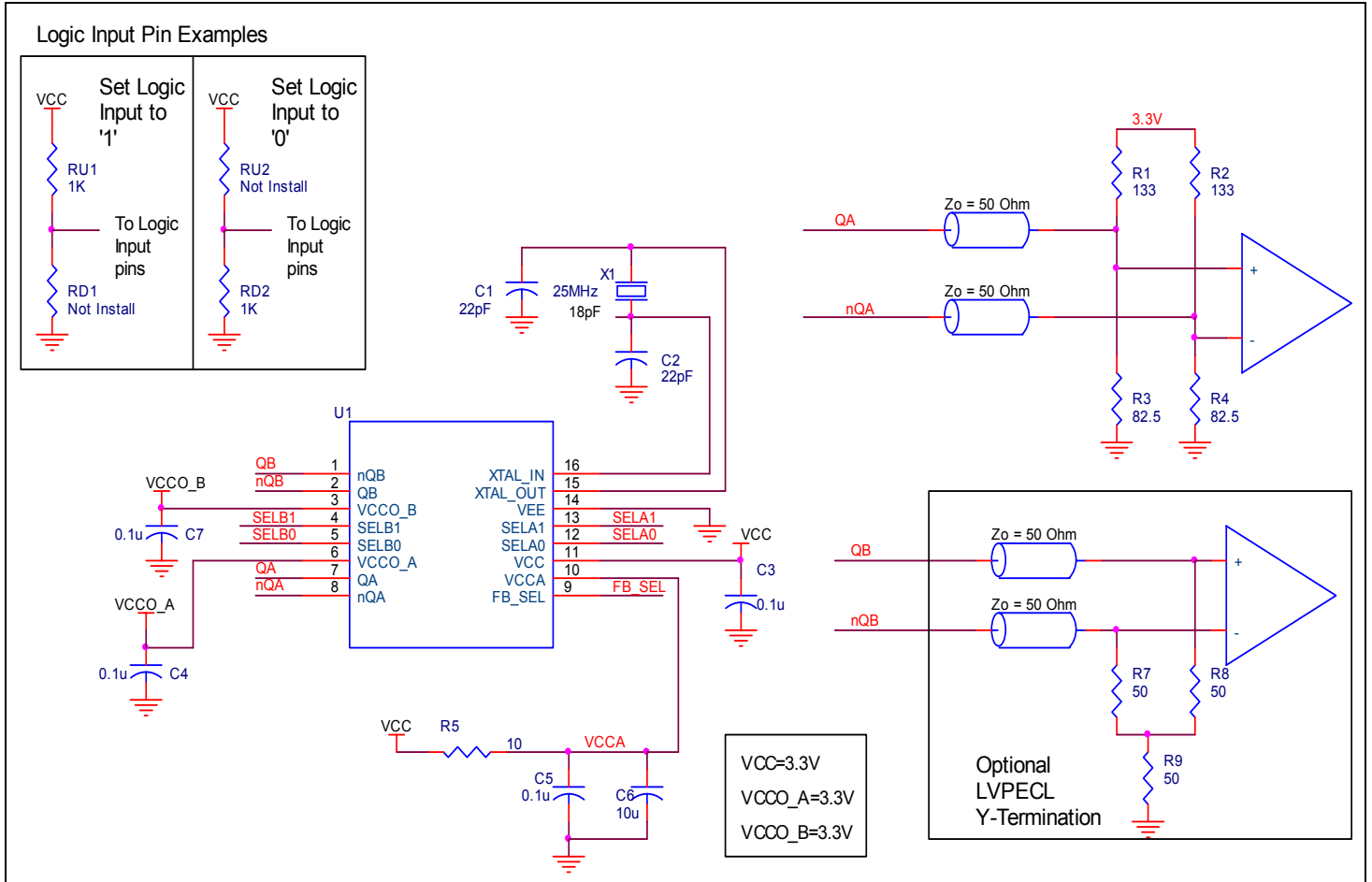

Figure 5. ICS843252 Schematic Example

## Power Considerations

This section provides information on power dissipation and junction temperature for the ICS843252. Equations and example calculations are also provided.

### 1. Power Dissipation.

The total power dissipation for the ICS843252 is the sum of the core power plus the power dissipated in the load(s). The following is the power dissipation for  $V_{CC} = 3.3V + 5\% = 3.465V$ , which gives worst case results.

NOTE: Please refer to Section 3 for details on calculating power dissipated in the load.

- Power (core)<sub>MAX</sub> =  $V_{CC\_MAX} * I_{EE\_MAX} = 3.465V * 145mA = 502.43mW$
- Power (outputs)<sub>MAX</sub> = **30mW/Loaded Output pair**  
If all outputs are loaded, the total power is  $2 * 30mW = 60mW$

**Total Power**<sub>MAX</sub> (3.3V, with all outputs switching) =  $502.43mW + 60mW = 562.43mW$

### 2. Junction Temperature.

Junction temperature,  $T_j$ , is the temperature at the junction of the bond wire and bond pad and directly affects the reliability of the device. The maximum recommended junction temperature for HiPerClockS devices is 125°C.

The equation for  $T_j$  is as follows:  $T_j = \theta_{JA} * Pd\_total + T_A$

$T_j$  = Junction Temperature

$\theta_{JA}$  = Junction-to-Ambient Thermal Resistance

$Pd\_total$  = Total Device Power Dissipation (example calculation is in section 1 above)

$T_A$  = Ambient Temperature

In order to calculate junction temperature, the appropriate junction-to-ambient thermal resistance  $\theta_{JA}$  must be used. Assuming no air flow and a multi-layer board, the appropriate value is 92.4°C/W per Table 7 below.

Therefore,  $T_j$  for an ambient temperature of 70°C with all outputs switching is:

$$70^\circ\text{C} + 0.562\text{W} * 92.4^\circ\text{C/W} = 121.9^\circ\text{C}. \text{ This is below the limit of } 125^\circ\text{C}.$$

This calculation is only an example.  $T_j$  will obviously vary depending on the number of loaded outputs, supply voltage, air flow and the type of board (multi-layer).

**Table 7. Thermal Resistance  $\theta_{JA}$  for 16 Lead TSSOP, Forced Convection**

Meters per Second	$\theta_{JA}$ vs. Air Flow		
	0	1	2.5
Multi-Layer PCB, JEDEC Standard Test Boards	92.4°C/W	88.0°C/W	85.9°C/W

### 3. Calculations and Equations.

The purpose of this section is to derive the power dissipated into the load.

LVPECL output driver circuit and termination are shown in *Figure 6*.

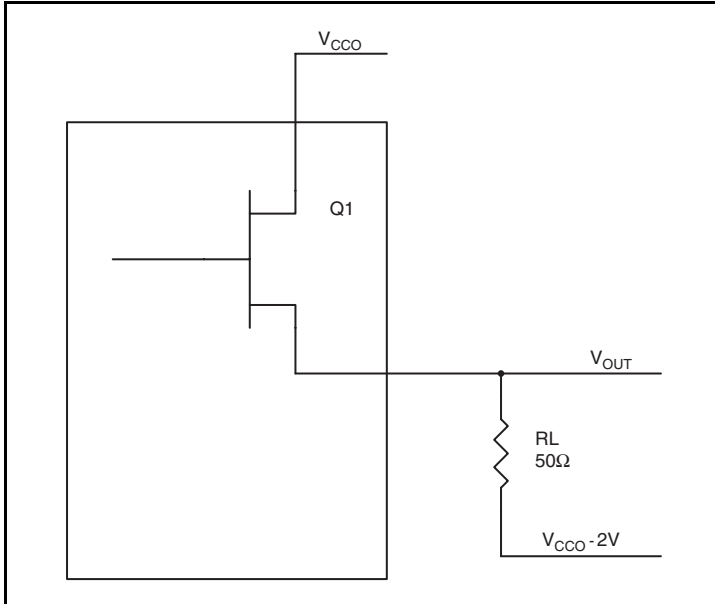

**Figure 6. LVPECL Driver Circuit and Termination**

To calculate worst case power dissipation into the load, use the following equations which assume a 50Ω load, and a termination voltage of  $V_{CCO} - 2V$ .

- For logic high,  $V_{OUT} = V_{OH\_MAX} = V_{CCO\_MAX} - 0.9V$   
( $V_{CCO\_MAX} - V_{OH\_MAX}$ ) = **0.9V**
- For logic low,  $V_{OUT} = V_{OL\_MAX} = V_{CCO\_MAX} - 1.7V$   
( $V_{CCO\_MAX} - V_{OL\_MAX}$ ) = **1.7V**

$Pd\_H$  is power dissipation when the output drives high.

$Pd\_L$  is the power dissipation when the output drives low.

$$Pd\_H = [(V_{OH\_MAX} - (V_{CCO\_MAX} - 2V))/R_L] * (V_{CCO\_MAX} - V_{OH\_MAX}) = [(2V - (V_{CCO\_MAX} - V_{OH\_MAX}))/R_L] * (V_{CCO\_MAX} - V_{OH\_MAX}) = [(2V - 0.9V)/50\Omega] * 0.9V = \mathbf{19.8mW}$$

$$Pd\_L = [(V_{OL\_MAX} - (V_{CCO\_MAX} - 2V))/R_L] * (V_{CCO\_MAX} - V_{OL\_MAX}) = [(2V - (V_{CCO\_MAX} - V_{OL\_MAX}))/R_L] * (V_{CCO\_MAX} - V_{OL\_MAX}) = [(2V - 1.7V)/50\Omega] * 1.7V = \mathbf{10.2mW}$$

Total Power Dissipation per output pair =  $Pd\_H + Pd\_L = \mathbf{30mW}$

## Reliability Information

Table 8.  $\theta_{JA}$  vs. Air Flow Table for a 16 Lead TSSOP

$\theta_{JA}$ vs. Air Flow			
Meters per Second	0	1	2.5
Multi-Layer PCB, JEDEC Standard Test Boards	92.4°C/W	88.0°C/W	85.9°C/W

## Transistor Count

The transistor count for ICS843252 is: 3822

## Package Outline and Package Dimensions

Package Outline - G Suffix for 16-Lead TSSOP

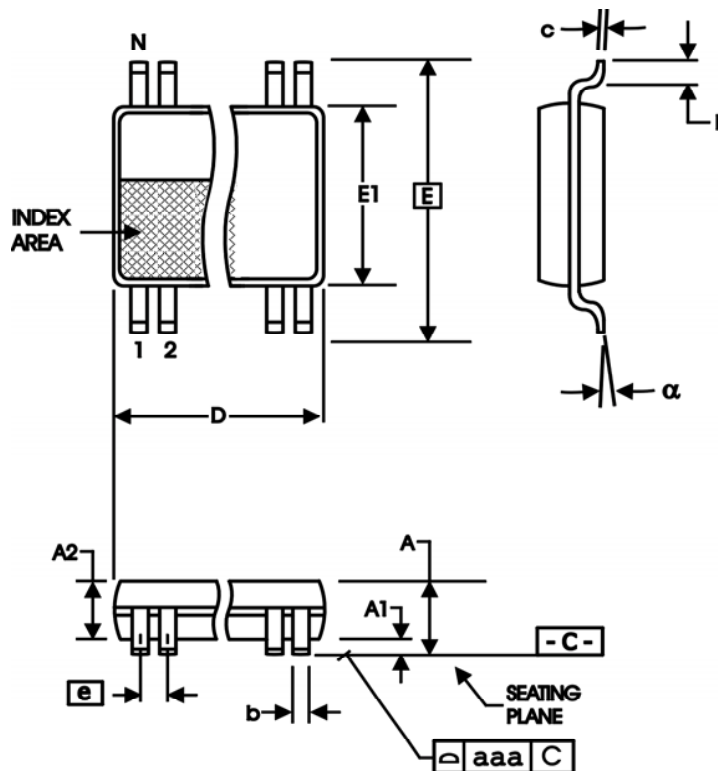

Table 9. Package Dimensions for 16 Lead TSSOP

All Dimensions in Millimeters		
Symbol	Minimum	Maximum
N	16	
A		1.20
A1	0.05	0.15
A2	0.80	1.05
b	0.19	0.30
c	0.09	0.20
D	4.90	5.10
E	6.40 Basic	
E1	4.30	4.50
e	0.65 Basic	
L	0.45	0.75
$\alpha$	0°	8°
aaa		0.10

Reference Document: JEDEC Publication 95, MO-153

## Ordering Information

Table 10. Ordering Information

Part/Order Number	Marking	Package	Shipping Packaging	Temperature
843252AG	843252AG	16 Lead TSSOP	Tube	0°C to 70°C
843252AGT	843252AG	16 Lead TSSOP	2500 Tape & Reel	0°C to 70°C
843252AGLF	843252AL	"Lead-Free" 16 Lead TSSOP	Tube	0°C to 70°C
843252AGLFT	843252AL	"Lead-Free" 16 Lead TSSOP	2500 Tape & Reel	0°C to 70°C

NOTE: Parts that are ordered with an "LF" suffix to the part number are the Pb-Free configuration and are RoHS compliant.

While the information presented herein has been checked for both accuracy and reliability, Integrated Device Technology (IDT) assumes no responsibility for either its use or for the infringement of any patents or other rights of third parties, which would result from its use. No other circuits, patents, or licenses are implied. This product is intended for use in normal commercial applications. Any other applications, such as those requiring extended temperature ranges, high reliability or other extraordinary environmental requirements are not recommended without additional processing by IDT. IDT reserves the right to change any circuitry or specifications without notice. IDT does not authorize or warrant any IDT product for use in life support devices or critical medical instruments.

ICS843252

FEMTOCLOCK™ CRYSTAL-TO- 3.3V LVPECL FREQUENCY SYNTHESIZER

## Contact Information:

**www.IDT.com**

### Sales

800-345-7015 (inside USA)  
+408-284-8200 (outside USA)  
Fax: 408-284-2775  
[www.IDT.com/go/contactIDT](http://www.IDT.com/go/contactIDT)

### Technical Support

[netcom@idt.com](mailto:netcom@idt.com)  
+480-763-2056

### Corporate Headquarters

Integrated Device Technology, Inc.  
6024 Silver Creek Valley Road  
San Jose, CA 95138  
United States  
800-345-7015 (inside USA)  
+408-284-8200 (outside USA)

