

General Description

The ICS8430S10I is a PLL-based clock generator specifically designed for Cavium Networks SoC processors. This high performance device is optimized to generate the processor core reference clock, the DDR reference clocks, the PCI/PCI-X bus clocks, and the clocks for both the Gigabit Ethernet MAC and PHY. The clock generator offers ultra low-jitter, low-skew clock outputs, and edge rates that easily meet the input requirements for the CN30XX/ CN31XX/CN38XX/CN58XX processors. The output frequencies are generated from a 25MHz external input source or an external 25MHz parallel resonant crystal. The extended temperature range of the ICS8430S10I supports telecommunication, networking, and storage requirements.

Applications

- Systems using Cavium Processors
- CPE Gateway Design
- Home Media Servers
- 802.11n AP or Gateway
- SOHO Secure Gateway
- SOHO SME Gateway
- Wireless Soho and SME VPN Solutions
- Wired and Wireless Network Security
- Web Servers and Exchange Servers

Features

- One selectable clock for DDR 400/533/667, LVPECL/LVDS interface levels
- Nine LVCMOS/ LVTTTL outputs, 15Ω typical output impedance
- Selectable external crystal or differential input source
- Crystal oscillator interface designed for 25MHz, parallel resonant crystal
- Differential input pair (CLK, nCLK) accepts LVPECL, LVDS, SSTL input levels
- Internal resistor bias on nCLK pin allows the user to drive CLK input with external single-ended (LVCMOS/ LVTTTL) input levels
- Power output supply modes
LVDS and LVPECL – full 3.3V
LVCMOS – full 3.3V or mixed 3.3V core/2.5V output
- -40°C to 85°C ambient operating temperature
- Available in lead-free (RoHS 6) package

Pin Assignment

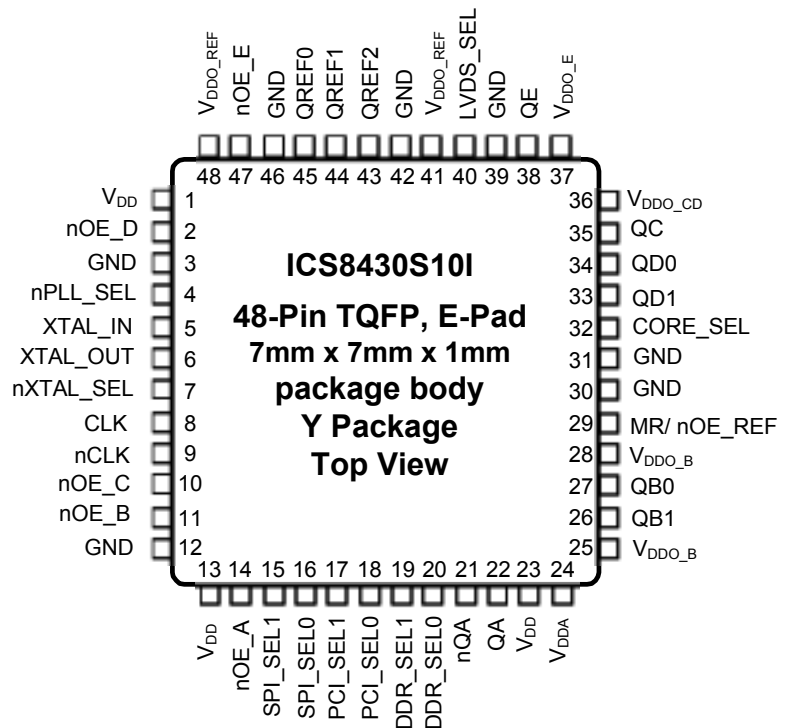

Block Diagram

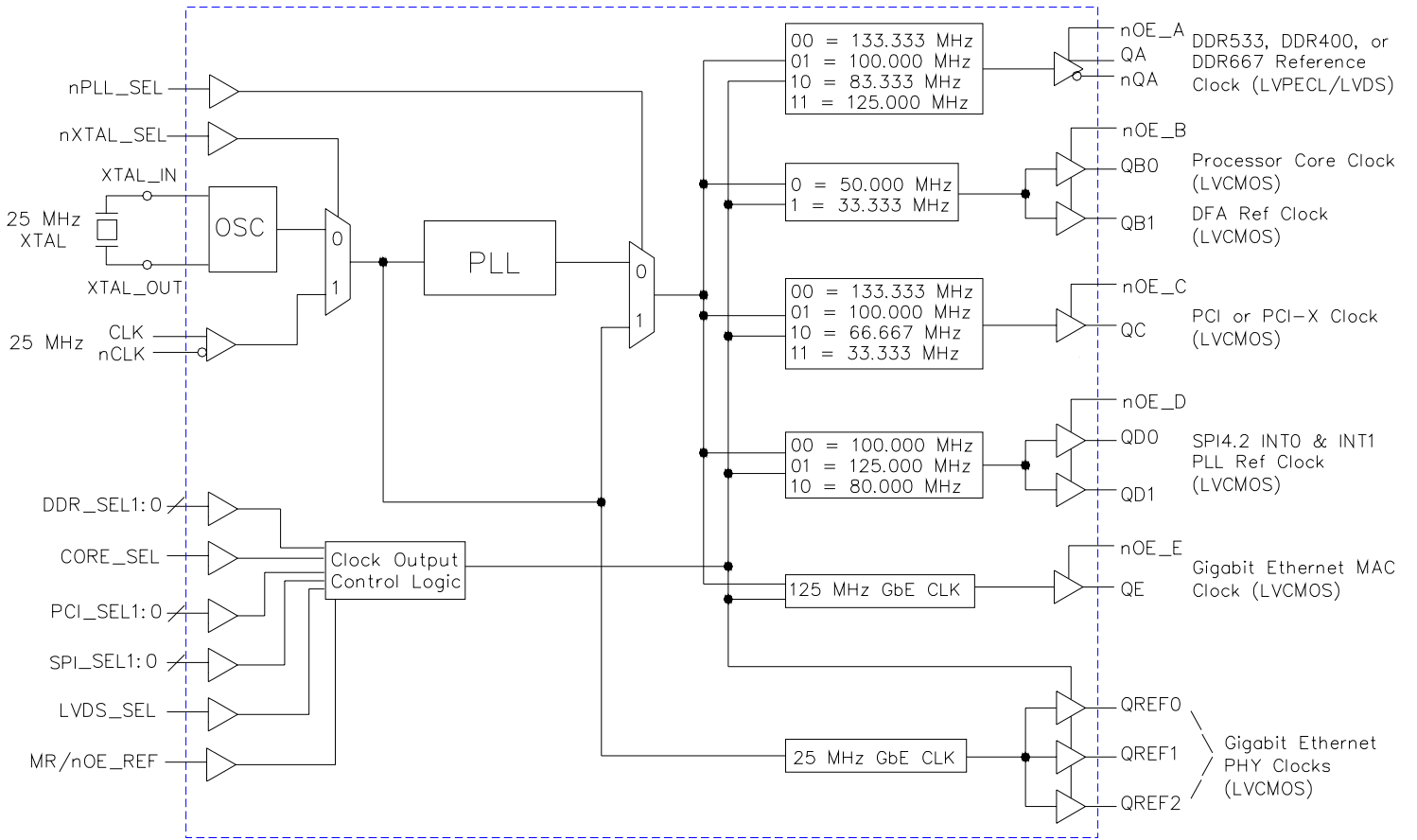

Table 1. Pin Descriptions

Number	Name	Type		Description
1, 13, 23	V _{DD}	Power		Core supply pins.
2	nOE_D	Input	Pulldown	Active LOW output enable for Bank D outputs. When logic HIGH, the outputs are in high impedance (HI-Z). When logic LOW, the outputs are enabled. LVCMOS/LVTTL interface levels.
3, 12, 30, 31, 39, 42, 46	GND	Power		Power supply ground.
4	nPLL_SEL	Input	Pulldown	PLL bypass. When LOW, selects PLL (PLL Enable). When HIGH, deselects the reference clock (PLL Bypass). LVCMOS/LVTTL interface levels.
5, 6	XTAL_IN, XTAL_OUT	Input		Parallel resonant crystal interface. XTAL_OUT is the output, XTAL_IN is the input.
7	nXTAL_SEL	Input	Pulldown	Selects XTAL inputs when LOW. Selects differential clock (CLK, nCLK) input when HIGH. LVCMOS/LVTTL interface levels.
8	CLK	Input	Pulldown	Non-inverting differential clock input.
9	nCLK	Input	Pullup/ Pulldown	Inverting differential clock input. Internal resistor bias to V _{DD} /2.
10	nOE_C	Input	Pulldown	Active LOW output enable for Bank C output. When logic HIGH, QC output is in high impedance (HI-Z). When logic LOW, QC output is enabled. LVCMOS/LVTTL interface levels.
11	nOE_B	Input	Pulldown	Active LOW output enable for Bank B outputs. When logic HIGH, the outputs are in high impedance (HI-Z). When logic LOW, the outputs are enabled. LVCMOS/LVTTL interface levels.
14	nOE_A	Input	Pulldown	Active LOW output enable for Bank A outputs. When logic HIGH, the output pair drives differential LOW (QA = LOW, nQA = HIGH). When logic LOW, the outputs are enabled. LVCMOS/LVTTL interface levels.
15, 16	SPI_SEL1, SPI_SEL0	Input	Pulldown	Selects the SPI PLL reference clock output frequency. See Table 3D.
17, 18	PCI_SEL1, PCI_SEL0	Input	Pulldown	Selects the PC,I PCI-X reference clock output frequency. See Table 3C. LVCMOS/LVTTL interface levels.
19, 20	DDR_SEL1, DDR_SEL0	Input	Pulldown	Selects the DDR reference clock output frequency. See Table 3B. LVCMOS/LVTTL interface levels.
21, 22	nQA, QA	Output		Differential output pair. Selectable between LVPECL and LVDS interface levels.
24	V _{DDA}	Power		Analog supply pin.
25, 28	V _{DDO_B}	Power		Bank B output supply pins. 3.3 V or 2.5V supply.
26, 27	QB1, QB0	Output		Single-ended Bank B outputs. LVCMOS/LVTTL interface levels.
29	MR/nOE_REF	Input	Pulldown	Active HIGH Master Reset. Active LOW output enable. When logic HIGH, the internal dividers are reset and the QREF[2:0] outputs are in high impedance (HI-Z). When logic LOW, the internal dividers and the outputs are enabled. LVCMOS/ LVTTL interface levels.
32	CORE_SEL	Input	Pulldown	Selects the processor core clock output frequency. The output frequency is 50MHz when LOW, and 33.333MHz when HIGH. See Table 3A. LVCMOS/LVTTL interface levels.
33, 34	QD1, QD0	Output		Single-end Bank D outputs. LVCMOS/LVTTL interface levels.
35	QC	Output		Single-end Bank C output. LVCMOS/LVTTL interface levels.
36	V _{DDO_CD}	Power		Bank C and Bank D output supply pin. 3.3 V or 2.5V supply.

Pin descriptions continue on the next page.

Number	Name	Type		Description
37	V _{DDO_E}	Power		Bank E output supply pin. 3.3 V or 2.5V supply.
38	QE	Output		Single-end Bank E output. LVCMOS/LVTTL interface levels.
40	LVDS_SEL	Input	Pulldown	Selects between LVDS and LVPECL interface levels on differential output pair QA and nQA. When LOW, LVDS interface levels are selected. When HIGH, LVPECL is selected. See table 3E.
41, 48	V _{DDO_REF}	Power		Bank QREF output supply pins. 3.3 V or 2.5V supply.
43, 44, 45	QREF2, QREF1, QREF0	Output		Single-ended reference clock outputs. LVCMOS/LVTTL interface levels.
47	nOE_E	Input	Pulldown	Active LOW output enable for Bank E outputs. When logic HIGH, the outputs are in high impedance (HI-Z). When logic LOW, the outputs are enabled. LVCMOS/LVTTL interface levels.

NOTE: Pullup and Pulldown refer to internal input resistors. See Table 2, *Pin Characteristics*, for typical values.

Table 2. Pin Characteristics

Symbol	Parameter	Test Conditions	Minimum	Typical	Maximum	Units
C _{IN}	Input Capacitance			2		pF
C _{PD}	Power Dissipation Capacitance (per output)	V _{DD} , V _{DDO_X} = 3.465V		4		pF
		V _{DD} = 3.465V, V _{DDO_X} = 2.625V		4		pF
R _{PULLUP}	Input Pullup Resistor			51		kΩ
R _{PULLDOWN}	Input Pulldown Resistor			51		kΩ
R _{OUT}	Output Impedance	QB[0:1], QC, QD[0:1], QE QREF[0:2] V _{DDO_X} = 3.465V		15		Ω
		QB[0:1], QC, QD[0:1], QE QREF[0:2] V _{DDO_X} = 2.625V		20		Ω

NOTE: V_{DDO_X} denotes V_{DDO_B}, V_{DDO_CD}, V_{DDO_E} and V_{DDO_REF}.

Function Tables

Table 3A. CORE_SEL Control Input Function Table

Input	Output Frequency
CORE_SEL	QB[0:1]
0 (default)	50MHz
1	33.333MHz

Table 3B. DDR_SEL Control Input Function Table

Inputs		Output Frequency
DDR_SEL1	DDR_SEL0	QA, nQA
0 (default)	0 (default)	133.333MHz
0	1	100.000MHz
1	0	83.333MHz
1	1	125.000MHz

Table 3C. PCI_SEL Control Input Function Table

Inputs		Output Frequency
PCI_SEL1	PCI_SEL0	QC
0 (default)	0 (default)	133.333MHz
0	1	100.000MHz
1	0	66.6667MHz
1	1	33.333MHz

Table 3D. SPI_SEL Control Input Function Table

Inputs		Output Frequency
SPI_SEL1	SPI_SEL0	QD[0:1]
0 (default)	0 (default)	100.000MHz
0	1	125.000MHz
1	0	80.000MHz

Table 3E. LVDS_SEL Control Input Function Table

Input	Output Levels
LVDS_SEL	QA, nQA
0 (default)	LVDS
1	LVPECL

Absolute Maximum Ratings

NOTE: Stresses beyond those listed under *Absolute Maximum Ratings* may cause permanent damage to the device. These ratings are stress specifications only. Functional operation of product at these conditions or any conditions beyond those listed in the *DC Characteristics* or *AC Characteristics* is not implied. Exposure to absolute maximum rating conditions for extended periods may affect product reliability.

Item	Rating
Supply Voltage, V_{DD}	4.6V
Inputs, V_I	-0.5V to $V_{DD} + 0.5V$
Outputs, V_O (LVCMOS)	-0.5V to $V_{DD} + 0.5V$
Outputs, I_O (LVDS) Continuous Current Surge Current	10mA 15mA
Outputs, I_O (LVPECL) Continuous Current Surge Current	50mA 100mA
Package Thermal Impedance, θ_{JA}	33.1°C/W (0 mps)
Storage Temperature, T_{STG}	-65°C to 150°C

DC Electrical Characteristics

Table 4A. LVCMOS Power Supply DC Characteristics, $V_{DD} = V_{DDO_X} = 3.3V \pm 5\%$, $T_A = -40^\circ\text{C}$ to 85°C

Symbol	Parameter	Test Conditions	Minimum	Typical	Maximum	Units
V_{DD}	Core Supply Voltage		3.135	3.3	3.465	V
V_{DDA}	Analog Supply Voltage		$V_{DD} - 0.24$	3.3	V_{DD}	V
V_{DDO_X}	Output Supply Voltage		3.135	3.3	3.465	V
I_{DD}	Power Supply Current				180	mA
I_{DDA}	Analog Supply Current				24	mA
I_{DDO_X}	Output Supply Current	No Load, CLK selected			48	mA

NOTE: V_{DDO_X} denotes V_{DDO_B} , V_{DDO_CD} and V_{DDO_REF}

Table 4B. LVCMOS Power Supply DC Characteristics, $V_{DD} = 3.3V \pm 5\%$, $V_{DDO_X} = 2.5V \pm 5\%$, $T_A = -40^\circ\text{C}$ to 85°C

Symbol	Parameter	Test Conditions	Minimum	Typical	Maximum	Units
V_{DD}	Core Supply Voltage		3.135	3.3	3.465	V
V_{DDA}	Analog Supply Voltage		$V_{DD} - 0.24$	3.3	V_{DD}	V
V_{DDO_X}	Output Supply Voltage		2.375	2.5	2.625	V
I_{DD}	Power Supply Current				170	mA
I_{DDA}	Analog Supply Current				24	mA
I_{DDO_X}	Output Supply Current	No Load, CLK selected			36	mA

NOTE: V_{DDO_X} denotes V_{DDO_B} , V_{DDO_CD} and V_{DDO_REF} .

Table 4C. LVPECL Power Supply DC Characteristics, $V_{DD} = 3.3V \pm 5\%$, $T_A = -40^\circ\text{C}$ to 85°C

Symbol	Parameter	Test Conditions	Minimum	Typical	Maximum	Units
V_{DD}	Core Supply Voltage		3.135	3.3	3.465	V
V_{DDA}	Analog Supply Voltage		$V_{DD} - 0.24$	3.3	V_{DD}	V
I_{DD}	Power Supply Current				180	mA
I_{DDA}	Analog Supply Current				24	mA

Table 4D. LVDS Power Supply DC Characteristics, $V_{DD} = 3.3V \pm 5\%$, $T_A = -40^\circ\text{C}$ to 85°C

Symbol	Parameter	Test Conditions	Minimum	Typical	Maximum	Units
V_{DD}	Core Supply Voltage		3.135	3.3	3.465	V
V_{DDA}	Analog Supply Voltage		$V_{DD} - 0.24$	3.3	V_{DD}	V
I_{DD}	Power Supply Current				190	mA
I_{DDA}	Analog Supply Current				24	mA

Table 4E. LVCMOS/LVTTL DC Characteristics, $V_{DD} = 3.3V \pm 5\%$, $V_{DDO_X} = 3.3V \pm 5\%$ or $2.5V \pm 5\%$, $T_A = -40^\circ\text{C}$ to 85°C

Symbol	Parameter	Test Conditions	Minimum	Typical	Maximum	Units
V_{IH}	Input High Voltage		2.2		$V_{DD} + 0.3$	V
V_{IL}	Input Low Voltage		-0.3		0.8	V
I_{IH}	Input High Current	nXTAL_SEL, PCI_SEL[0:1], MR/nOE_REF, DDR_SEL[0:1], SPI_SEL[0:1], nOE_[A:E], nPLL_SEL, LVDS_SEL, CORE_SEL $V_{DD} = V_{IN} = 3.465V$			150	μA
I_{IL}	Input Low Current	nXTAL_SEL, PCI_SEL[0:1], MR/nOE_REF, DDR_SEL[0:1], SPI_SEL[0:1], nOE_[A:E], nPLL_SEL, LVDS_SEL, CORE_SEL $V_{DD} = 3.465V,$ $V_{IN} = 0V$	-5			μA
V_{OH}	Output High Voltage; NOTE 1	$V_{DDO_X} = 3.465V$	2.6			V
		$V_{DDO_X} = 2.625V$	1.8			V
V_{OL}	Output Low Voltage: NOTE 1	$V_{DDO_X} = 3.465V$ or $2.625V$			0.6	V

NOTE: V_{DDO_X} denotes V_{DDO_B} , V_{DDO_CD} , V_{DDO_E} and V_{DDO_REF} .

NOTE 1: Outputs terminated with 50Ω to $V_{DDO_X}/2$. See Parameter Measurement Information, *Output Load Test Circuit diagrams*.

Table 4F. Differential DC Characteristics, $V_{DD} = 3.3V \pm 5\%$, $T_A = -40^\circ C$ to $85^\circ C$

Symbol	Parameter	Test Conditions	Minimum	Typical	Maximum	Units
I_{IH}	Input High Current	CLK, nCLK $V_{DD} = V_{IN} = 3.465V$			150	μA
I_{IL}	Input Low Current	CLK $V_{DD} = 3.465V, V_{IN} = 0V$	-5			μA
		nCLK $V_{DD} = 3.465V, V_{IN} = 0V$	-150			μA
V_{PP}	Peak-to-Peak Input Voltage; NOTE 1		0.15		1.3	V
V_{CMR}	Common Mode Input Voltage; NOTE 1, 2		1.2		V_{DD}	V

NOTE: V_{DDO_X} denotes V_{DDO_B} , V_{DDO_CD} , V_{DDO_E} and V_{DDO_REF} .

NOTE 1: V_{IL} should not be less than -0.3V.

NOTE 2. Common mode voltage is defined as V_{IH} .

Table 4G. LVPECL DC Characteristics, $V_{DD} = 3.3V \pm 5\%$, $T_A = -40^\circ C$ to $85^\circ C$

Symbol	Parameter	Test Conditions	Minimum	Typical	Maximum	Units
V_{OH}	Output High Voltage; NOTE 1		$V_{DD} - 1.4$		$V_{DD} - 0.8$	V
V_{OL}	Output Low Voltage; NOTE 1		$V_{DD} - 2.0$		$V_{DD} - 1.7$	V
V_{SWING}	Peak-to-Peak Output Voltage Swing		0.6		1.0	V

NOTE 1: Outputs terminated with 50Ω to $V_{DD} - 2V$.

Table 4H. LVDS DC Characteristics, $V_{DD} = 3.3V \pm 5\%$, $T_A = -40^\circ C$ to $85^\circ C$

Symbol	Parameter	Test Conditions	Minimum	Typical	Maximum	Units
V_{OD}	Differential Output Voltage		300		600	mV
ΔV_{OD}	V_{OD} Magnitude Change				50	mV
V_{OS}	Offset Voltage		1.04		1.24	V
ΔV_{OS}	V_{OS} Magnitude Change				50	mV

Table 5. Crystal Characteristics

Parameter	Test Conditions	Minimum	Typical	Maximum	Units
Mode of Oscillation		Fundamental			
Frequency			25		MHz
Equivalent Series Resistance (ESR)				50	Ω
Shunt Capacitance				7	pF

NOTE: Characterized using an 18pF parallel resonant crystal.

AC Electrical Characteristics

Table 6. AC Characteristics, $V_{DD} = 3.3V \pm 5\%$, $V_{DDO_X} = 3.3V \pm 5\%$ or $2.5V \pm 5\%$, $T_A = -40^\circ\text{C}$ to 85°C

Symbol	Parameter	Test Conditions	Minimum	Typical	Maximum	Units	
f_{OUT}	Output Frequency	QA, nQA	DDR_SEL[1:0] = 00		133.333	MHz	
		QA, nQA	DDR_SEL[1:0] = 01		100	MHz	
		QA, nQA	DDR_SEL[1:0] = 10		83.333	MHz	
		QA, nQA	DDR_SEL[1:0] = 11		125	MHz	
		QBx	CORE_SEL = 0		50	MHz	
		QBx	CORE_SEL = 1		33.333	MHz	
		QCx	PCI_SEL[1:0] = 00		133.333	MHz	
		QCx	PCI_SEL[1:0] = 01		100	MHz	
		QCx	PCI_SEL[1:0] = 10		66.667	MHz	
		QCx	PCI_SEL[1:0] = 11		33.333	MHz	
$t_{sk(b)}$	Bank Skew; NOTE 2, 4	QREFx			30	ps	
$t_{sk(pp)}$	Part-to-Part Skew; NOTE 3, 4	QREFx			200	ps	
$t_{jit(cc)}$	Cycle-to-Cycle Jitter	QBx			365	ps	
		QC			300	ps	
		QDx			335	ps	
		QA, nQA	measured at crosspoint		150	ps	
		QE			260	ps	
$t_{jit(\emptyset)}$	RMS Phase Jitter, (Random); NOTE 1	QREFx	25MHz (10kHz to 5MHz)	0.64		ps	
		QE	125MHz (1.875MHz to 20MHz)	0.76		ps	
t_R / t_F	Output Rise/Fall Time	QBx	20% to 80%	100		450	ps
		QA, nQA		100		300	ps
		QC, QE, QREFx		100		650	ps
		QDx		100		650	ps
odc	Output Duty Cycle	QA, nQA		49		51	%
		QBx, QC, QDx, QE, QREFx		45		55	%

NOTE: Electrical parameters are guaranteed over the specified ambient operating temperature range, which is established when the device is mounted in a test socket with maintained transverse airflow greater than 500 lpm. The device will meet specifications after thermal equilibrium has been reached under these conditions.

NOTE: All parameters measured at f_{OUT} unless noted otherwise.

NOTE: V_{DDO_X} denotes V_{DDO_B} , V_{DDO_CD} , V_{DDO_E} and V_{DDO_REF} .

NOTE 1: Refer to the phase noise plot.

NOTE 2: Defined as skew within a bank of outputs at the same supply voltage and with equal load conditions.

NOTE 3: Defined as skew between outputs on different devices operating at the same supply voltage, same frequency, same temperature and with equal load conditions. Using the same type of inputs on each device, the outputs are measured at the differential cross points.

NOTE 4: This parameter is defined in accordance with JEDEC Standard 65.

Typical Phase Noise at 125MHz (QE output)

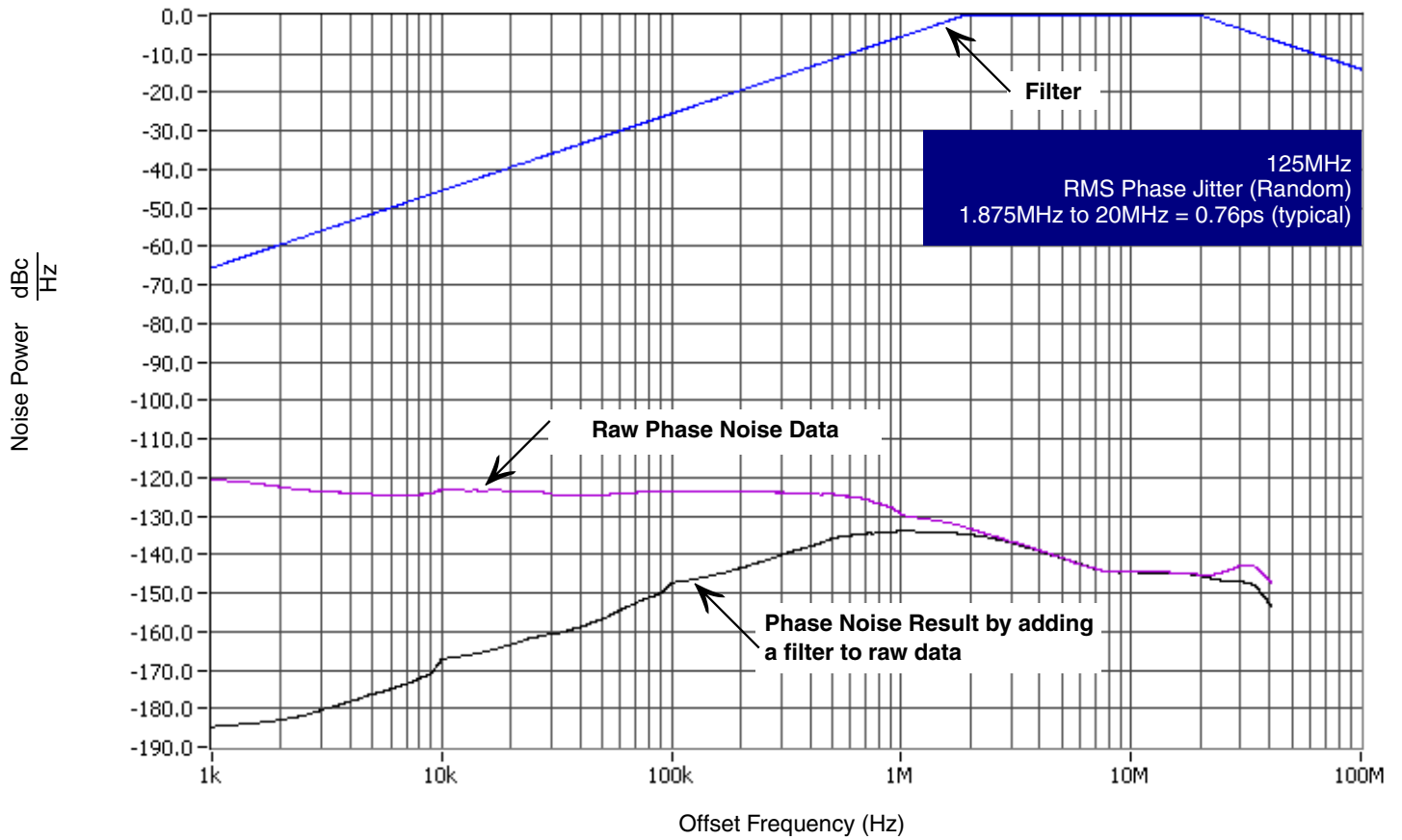

Typical Phase Noise at 25MHz (QREF output)

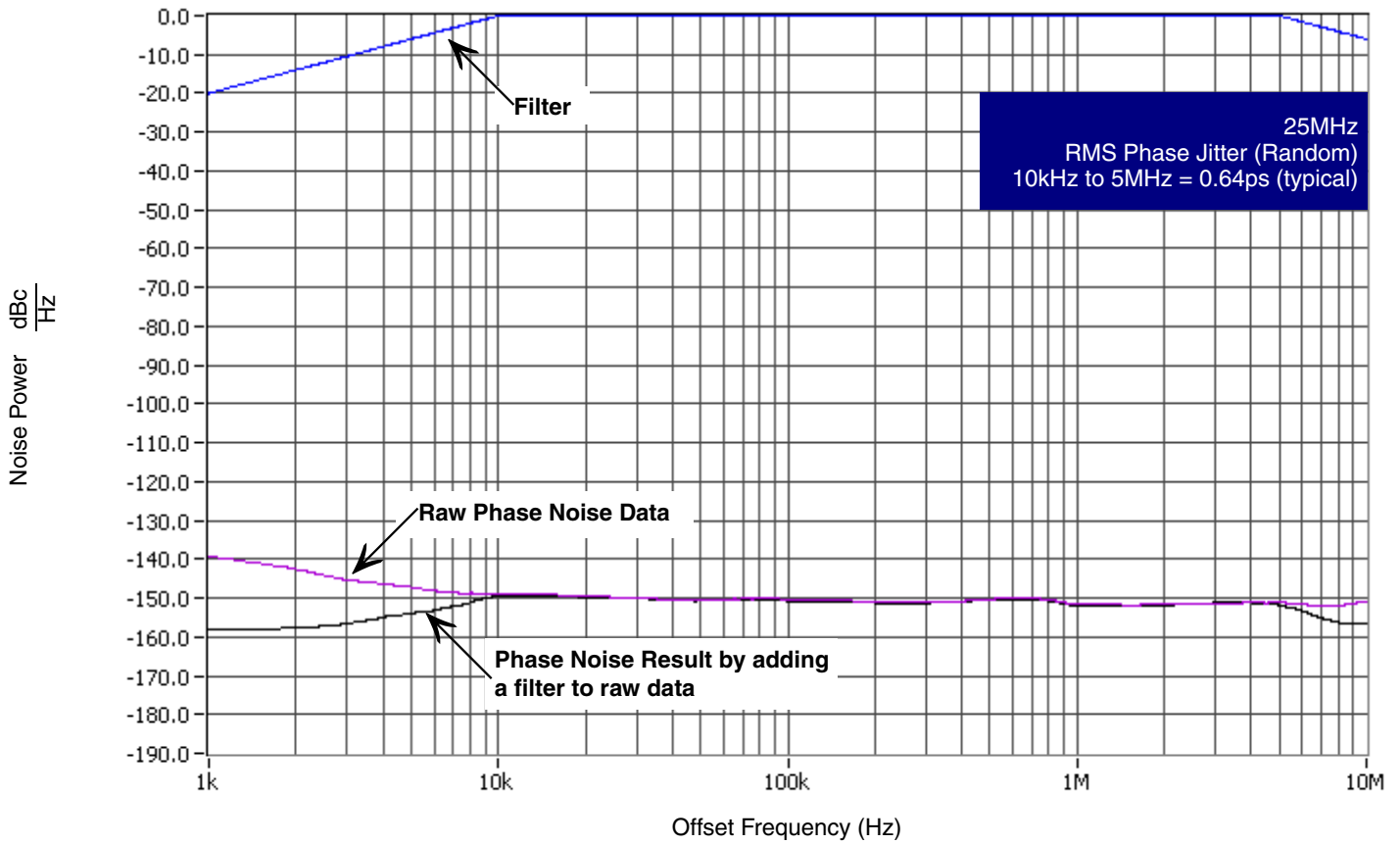

Parameter Measurement Information

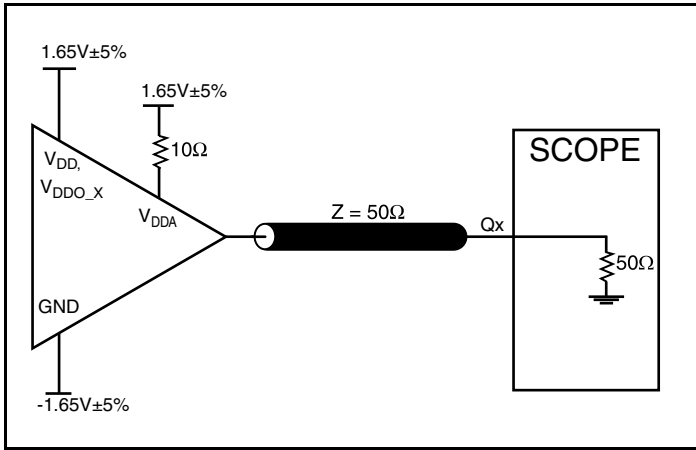

3.3V Core/3.3V LVCMOS Output Load AC Test Circuit

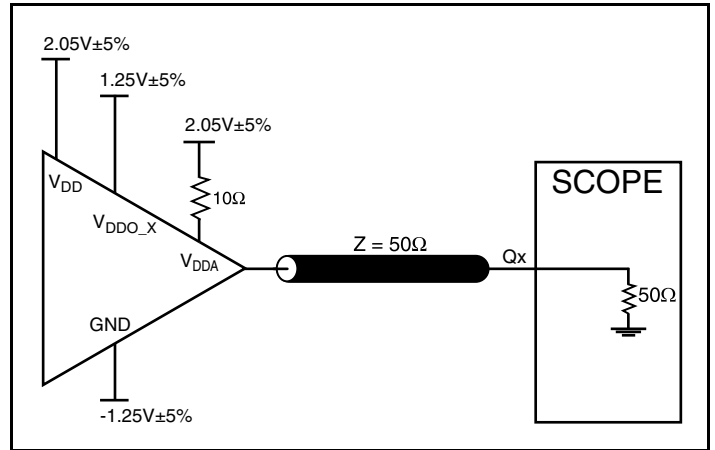

3.3V Core/2.5V LVCMOS Output Load AC Test Circuit

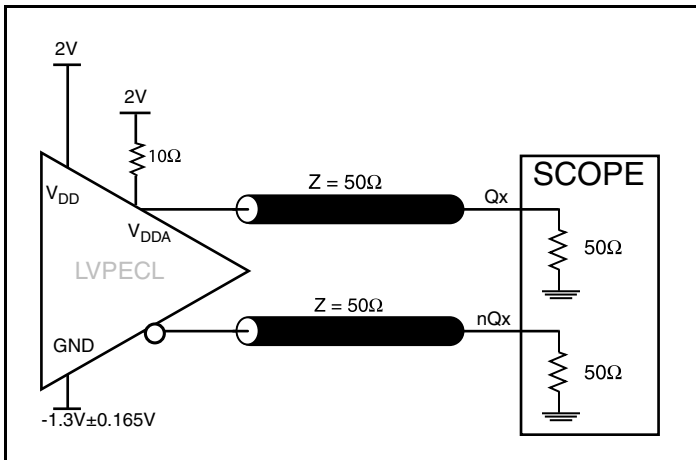

3.3V Core/3.3V LVPECL Output Load AC Test Circuit

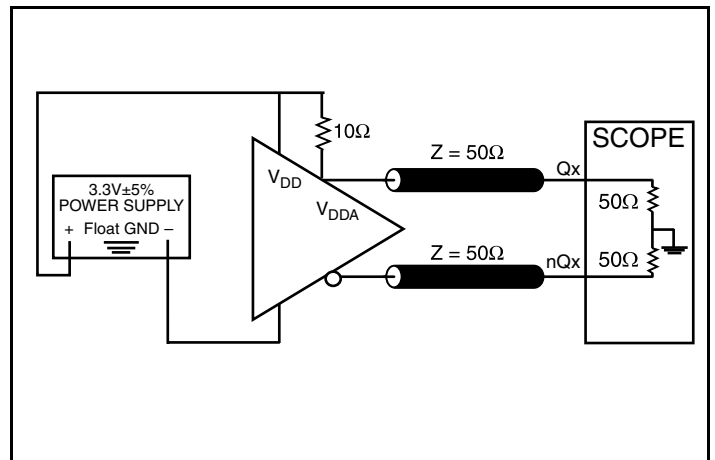

3.3V Core/3.3V LVDS Output Load AC Test Circuit

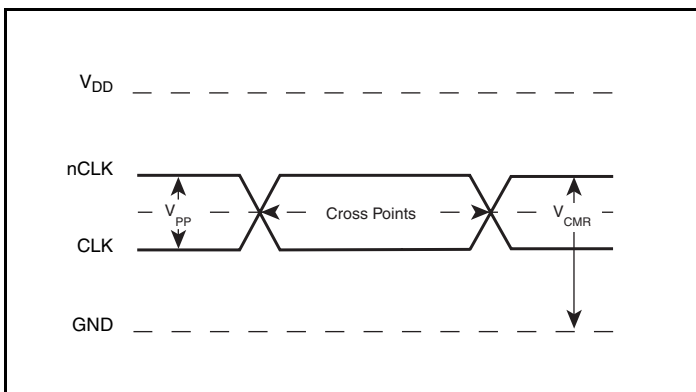

Differential Input Level

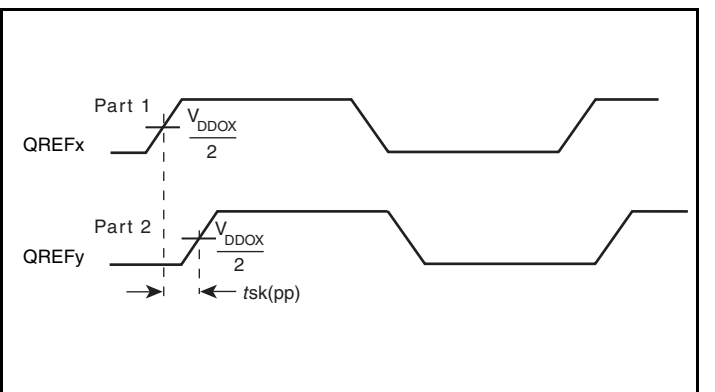

LVCMOS Part-to-Part Skew

Parameter Measurement Information, continued

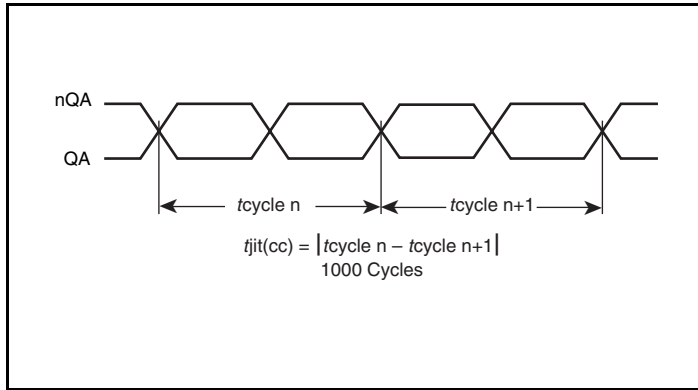

Differential Cycle-to-Cycle Jitter

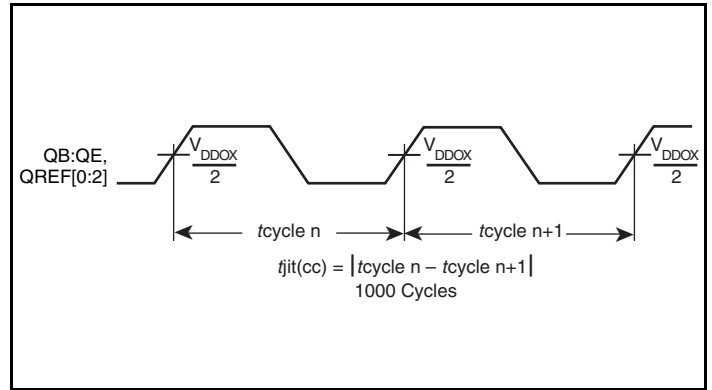

LVCMOS Cycle-to-Cycle Jitter

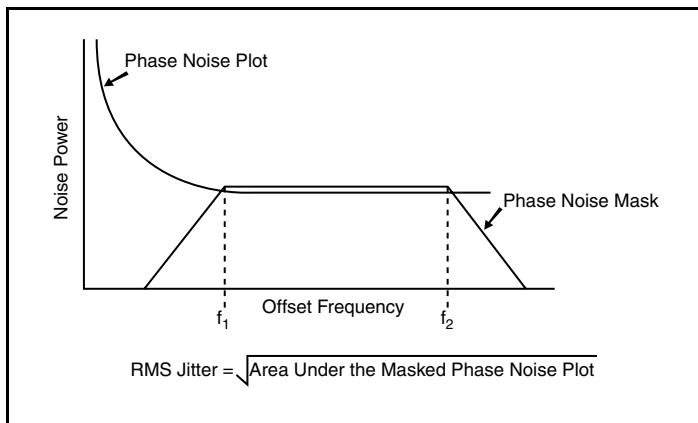

RMS Phase Jitter

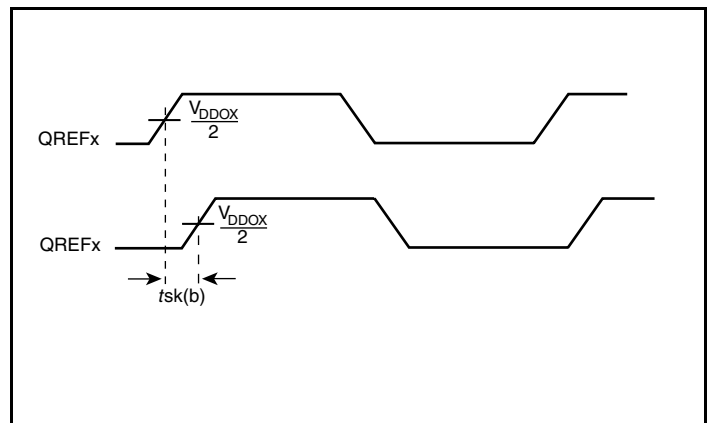

LVCMOS Bank Skew (where X denotes QREF0 1, or 2)

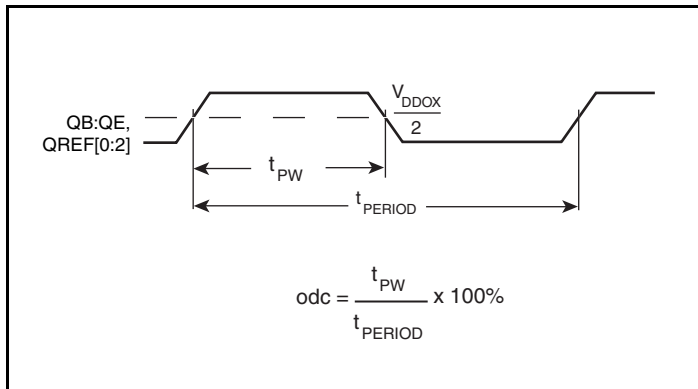

LVCMOS Output Duty Cycle/Pulse Width/Period

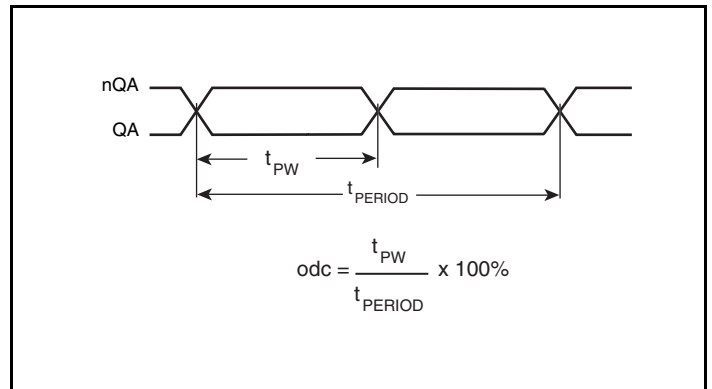

Differential Output Duty Cycle/Pulse Width/Period

Parameter Measurement Information, continued

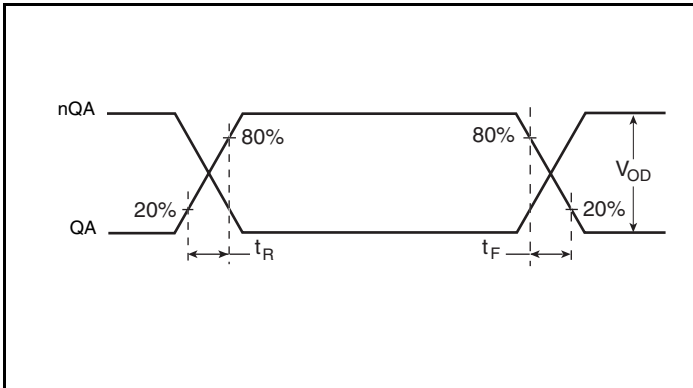

LVDS Output Rise/Fall Time

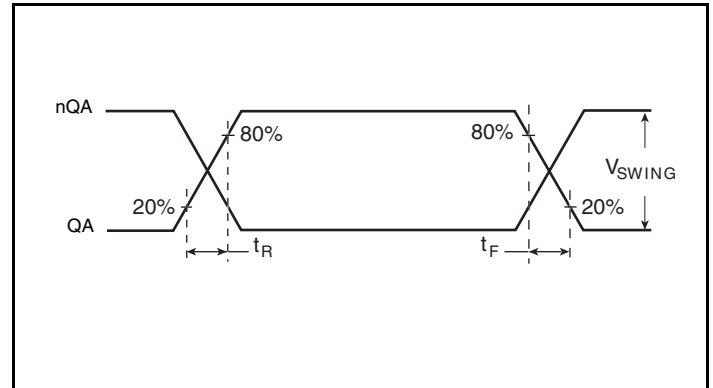

LVPECL Output Rise/Fall Time

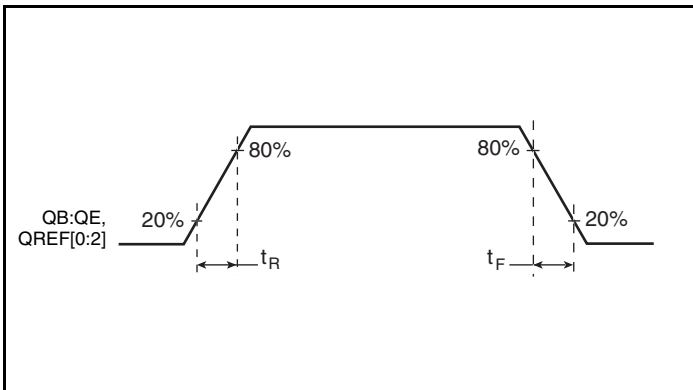

LVCMOS Output Rise/Fall Time

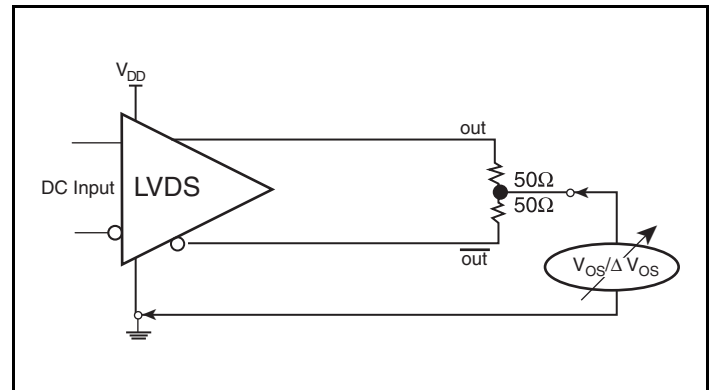

Offset Voltage Setup

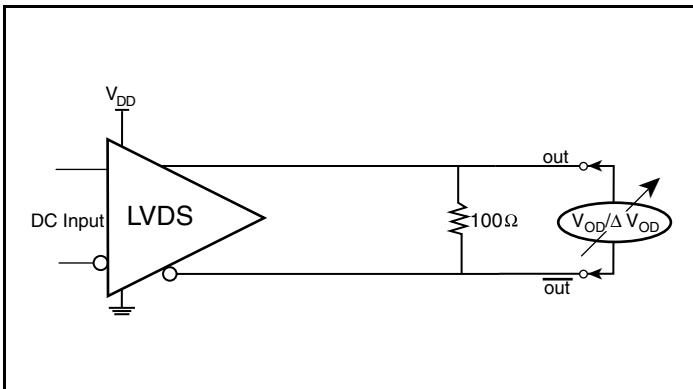

Differential Output Voltage Setup

Applications Information

Wiring the Differential Input to Accept Single-Ended Levels

Figure 1 shows how a differential input can be wired to accept single ended levels. The reference voltage $V_{REF} = V_{CC}/2$ is generated by the bias resistors R1 and R2. The bypass capacitor (C1) is used to help filter noise on the DC bias. This bias circuit should be located as close to the input pin as possible. The ratio of R1 and R2 might need to be adjusted to position the V_{REF} in the center of the input voltage swing. For example, if the input clock swing is 2.5V and $V_{CC} = 3.3V$, R1 and R2 value should be adjusted to set V_{REF} at 1.25V. The values below are for when both the single ended swing and V_{CC} are at the same voltage. This configuration requires that the sum of the output impedance of the driver (R_o) and the series resistance (R_s) equals the transmission line impedance. In addition, matched termination at the input will attenuate the signal in half. This can be done in one of two ways. First, R3 and R4 in parallel should equal the transmission

line impedance. For most 50 Ω applications, R3 and R4 can be 100 Ω . The values of the resistors can be increased to reduce the loading for slower and weaker LVCMOS driver. When using single-ended signaling, the noise rejection benefits of differential signaling are reduced. Even though the differential input can handle full rail LVCMOS signaling, it is recommended that the amplitude be reduced. The datasheet specifies a lower differential amplitude, however this only applies to differential signals. For single-ended applications, the swing can be larger, however V_{IL} cannot be less than -0.3V and V_{IH} cannot be more than $V_{CC} + 0.3V$. Though some of the recommended components might not be used, the pads should be placed in the layout. They can be utilized for debugging purposes. The datasheet specifications are characterized and guaranteed by using a differential signal.

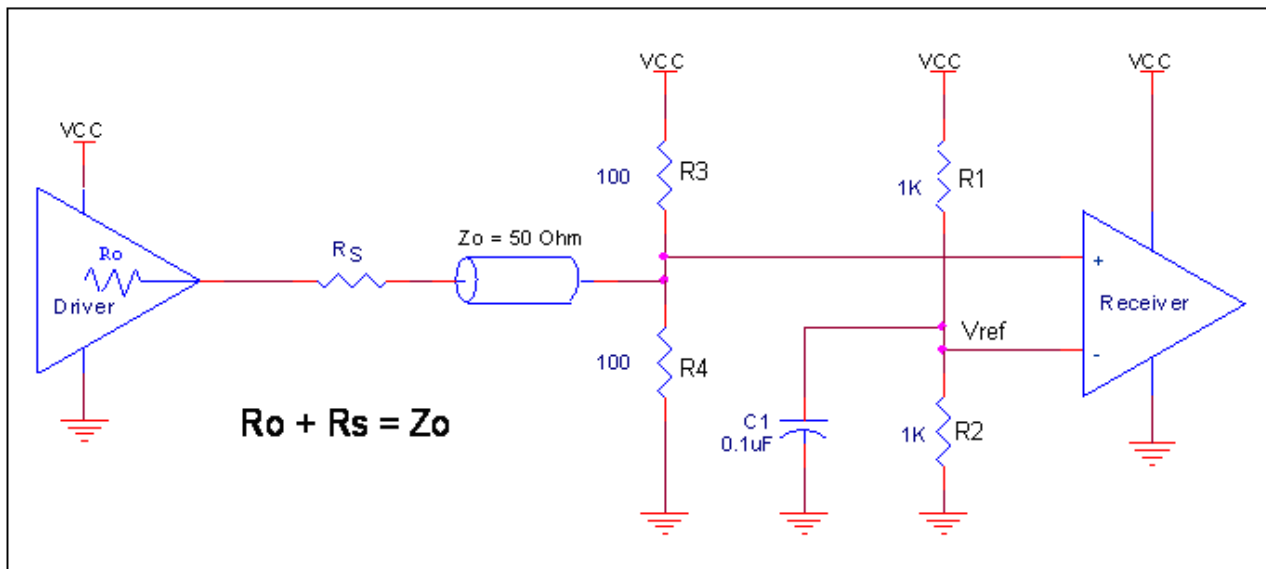

Figure 1. Recommended Schematic for Wiring a Differential Input to Accept Single-ended Levels

Differential Clock Input Interface

The CLK /nCLK accepts LVDS, LVPECL, SSTL, and other differential signals. Both V_{SWING} and V_{OH} must meet the V_{PP} and V_{CMR} input requirements. *Figures 2A to 2D* show interface examples for the CLK/nCLK input driven by the most common driver types. The input

interfaces suggested here are examples only. Please consult with the vendor of the driver component to confirm the driver termination requirements. If the driver is from another vendor, use their termination recommendation.

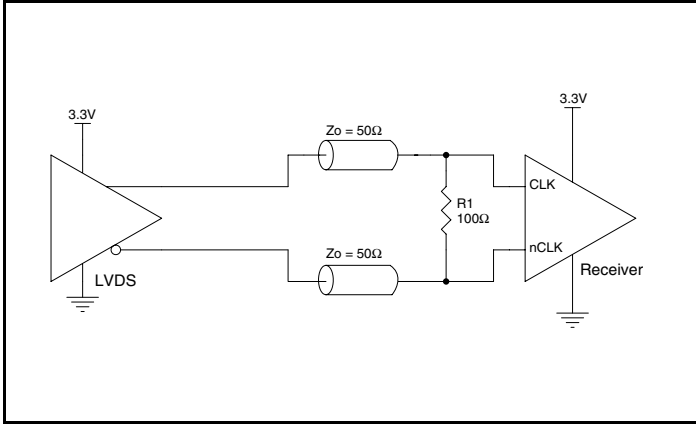

Figure 2A. CLK/nCLK Input Driven by a 3.3V LVDS Driver

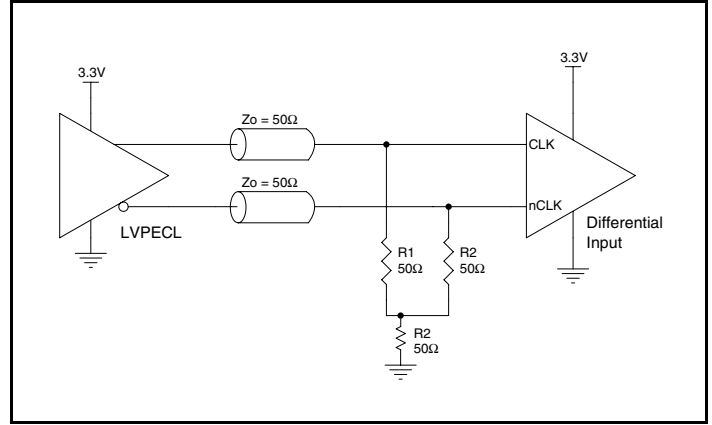

Figure 2B. CLK/nCLK Input Driven by a 3.3V LVPECL Driver

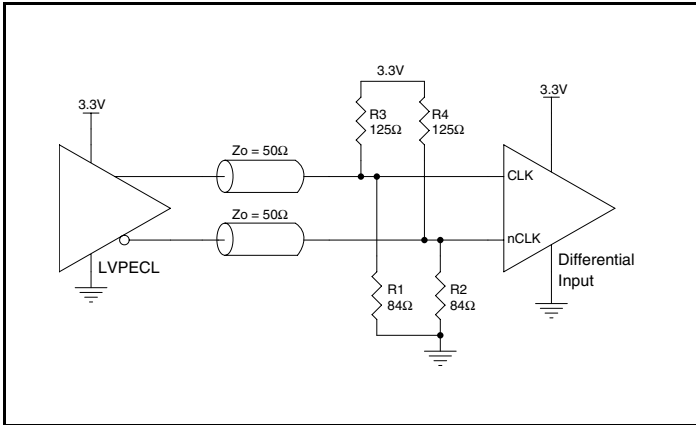

Figure 2C. CLK/nCLK Input Driven by a 3.3V LVPECL Driver

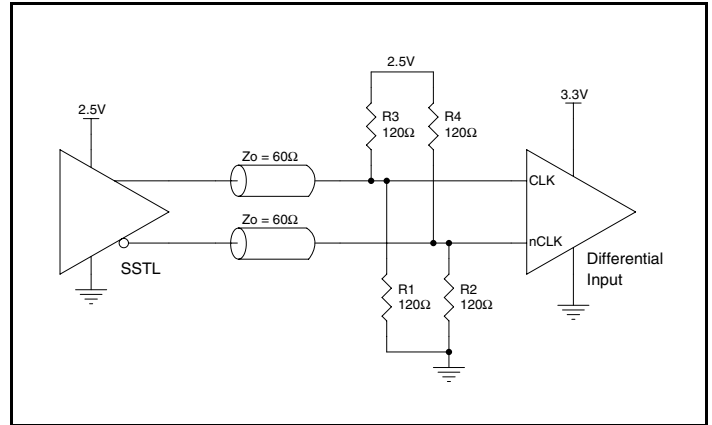

Figure 2D. CLK/nCLK Input Driven by a 2.5V SSTL Driver

Overdriving the XTAL Interface

The XTAL_IN input can accept a single-ended LVCMOS signal through an AC coupling capacitor. A general interface diagram is shown in *Figure 3A*. The XTAL_OUT pin can be left floating. The maximum amplitude of the input signal should not exceed 2V and the input edge rate can be as slow as 10ns. This configuration requires that the output impedance of the driver (R_o) plus the series resistance (R_s) equals the transmission line impedance. In addition,

matched termination at the crystal input will attenuate the signal in half. This can be done in one of two ways. First, R_1 and R_2 in parallel should equal the transmission line impedance. For most 50 Ω applications, R_1 and R_2 can be 100 Ω . This can also be accomplished by removing R_1 and making R_2 50 Ω . By overdriving the crystal oscillator, the device will be functional, but note, the device performance is guaranteed by using a quartz crystal.

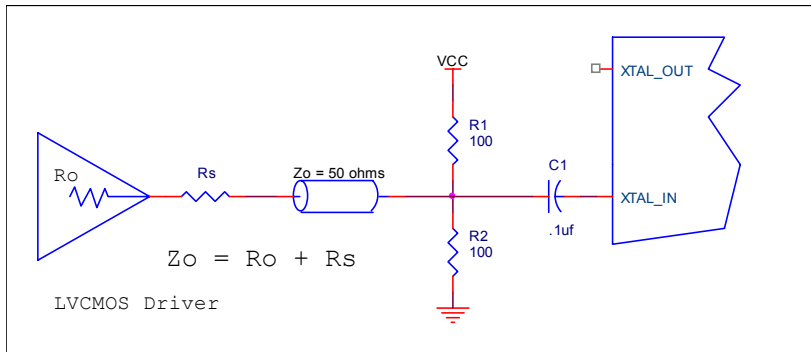

Figure 3A. General Diagram for LVCMOS Driver to XTAL Input Interface

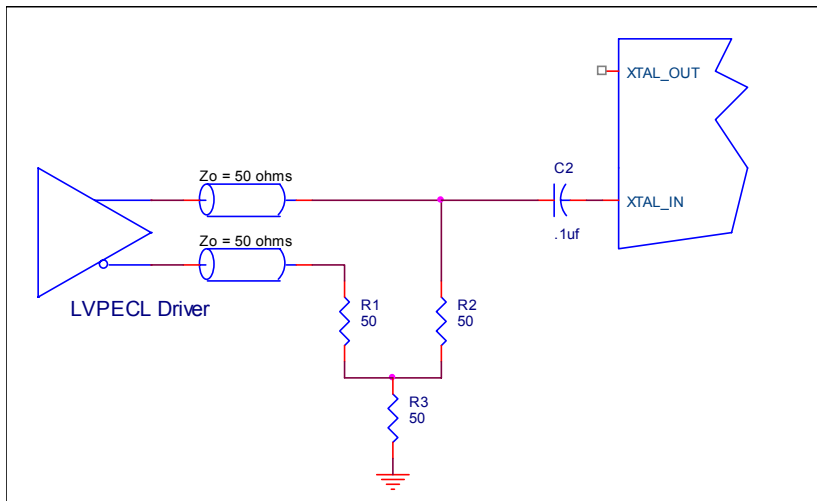

Figure 3B. General Diagram for LVPECL Driver to XTAL Input Interface

Termination for 3.3V LVPECL Outputs

The clock layout topology shown below is a typical termination for LVPECL outputs. The two different layouts mentioned are recommended only as guidelines.

The differential outputs are low impedance follower outputs that generate ECL/LVPECL compatible outputs. Therefore, terminating resistors (DC current path to ground) or current sources must be used for functionality. These outputs are designed to drive 50Ω

transmission lines. Matched impedance techniques should be used to maximize operating frequency and minimize signal distortion. *Figures 4A and 4B* show two different layouts which are recommended only as guidelines. Other suitable clock layouts may exist and it would be recommended that the board designers simulate to guarantee compatibility across all printed circuit and clock component process variations.

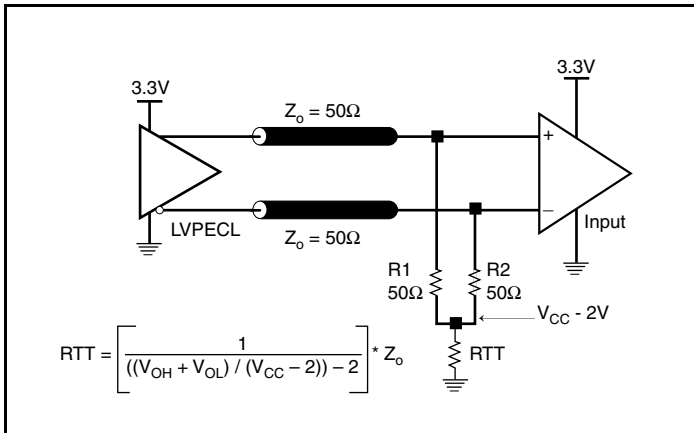

Figure 4A. 3.3V LVPECL Output Termination

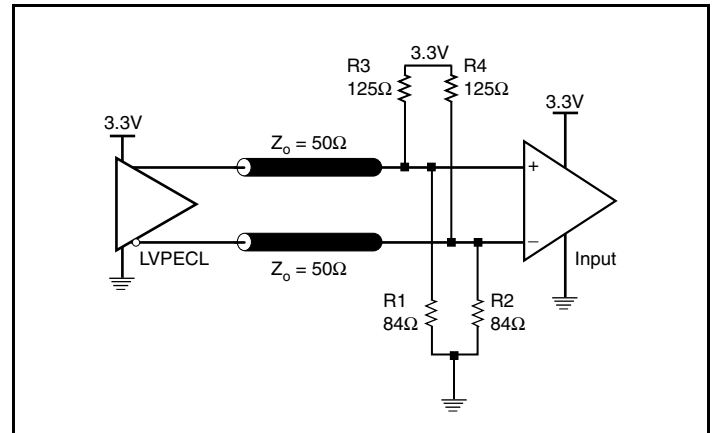

Figure 4B. 3.3V LVPECL Output Termination

LVDS Driver Termination

A general LVDS interface is shown in *Figure 5*. Standard termination for LVDS type output structure requires both a 100Ω parallel resistor at the receiver and a 100Ω differential transmission line environment. In order to avoid any transmission line reflection issues, the 100Ω resistor must be placed as close to the receiver as possible. IDT offers a full line of LVDS compliant devices with two types of output structures: current source and voltage source. The standard

termination schematic as shown in *Figure 5* can be used with either type of output structure. If using a non-standard termination, it is recommended to contact IDT and confirm if the output is a current source or a voltage source type structure. In addition, since these outputs are LVDS compatible, the amplitude and common mode input range of the input receivers should be verified for compatibility with the output.

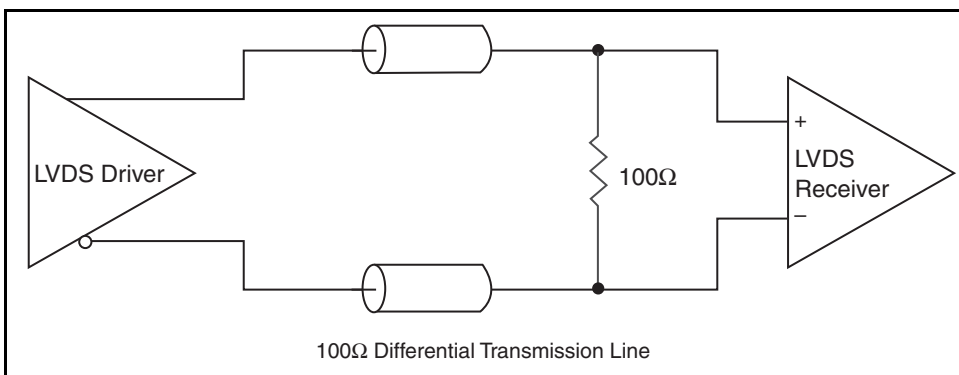

Figure 5. Typical LVDS Driver Termination

EPAD Thermal Release Path

In order to maximize both the removal of heat from the package and the electrical performance, a land pattern must be incorporated on the Printed Circuit Board (PCB) within the footprint of the package corresponding to the exposed metal pad or exposed heat slug on the package, as shown in *Figure 6*. The solderable area on the PCB, as defined by the solder mask, should be at least the same size/shape as the exposed pad/slug area on the package to maximize the thermal/electrical performance. Sufficient clearance should be designed on the PCB between the outer edges of the land pattern and the inner edges of pad pattern for the leads to avoid any shorts.

While the land pattern on the PCB provides a means of heat transfer and electrical grounding from the package to the board through a solder joint, thermal vias are necessary to effectively conduct from the surface of the PCB to the ground plane(s). The land pattern must be connected to ground through these vias. The vias act as “heat pipes”. The number of vias (i.e. “heat pipes”) are application specific

and dependent upon the package power dissipation as well as electrical conductivity requirements. Thus, thermal and electrical analysis and/or testing are recommended to determine the minimum number needed. Maximum thermal and electrical performance is achieved when an array of vias is incorporated in the land pattern. It is recommended to use as many vias connected to ground as possible. It is also recommended that the via diameter should be 12 to 13mils (0.30 to 0.33mm) with 1oz copper via barrel plating. This is desirable to avoid any solder wicking inside the via during the soldering process which may result in voids in solder between the exposed pad/slug and the thermal land. Precautions should be taken to eliminate any solder voids between the exposed heat slug and the land pattern. Note: These recommendations are to be used as a guideline only. For further information, please refer to the Application Note on the Surface Mount Assembly of Amkor’s Thermally/Electrically Enhance Leadframe Base Package, Amkor Technology.

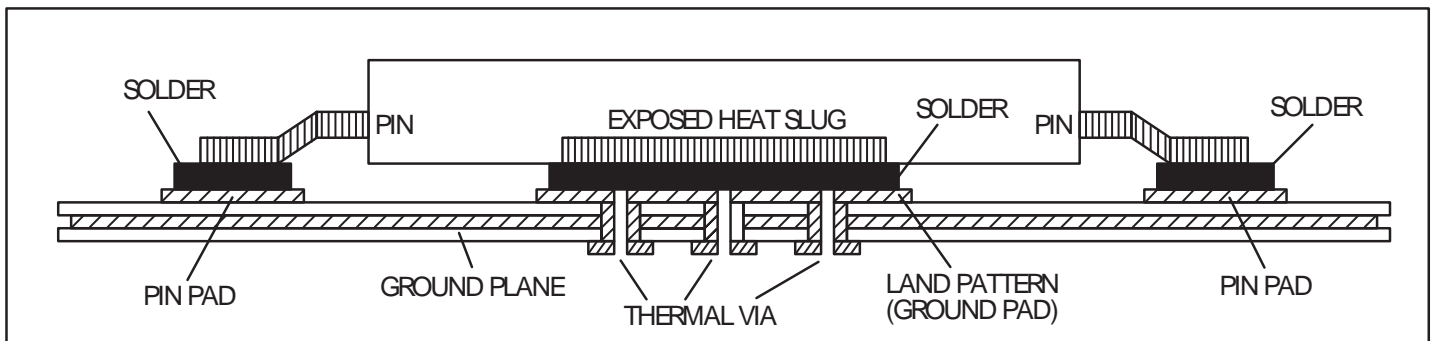

Figure 6. P.C. Assembly for Exposed Pad Thermal Release Path – Side View (drawing not to scale)

Recommendations for Unused Input and Output Pins

Inputs:

CLK/nCLK[̄]Inputs

For applications not requiring the use of the differential input, both CLK and nCLK can be left floating. Though not required, but for additional protection, a 1k Ω resistor can be tied from CLK to ground.

Crystal Inputs

For applications not requiring the use of the crystal oscillator input, both XTAL_IN and XTAL_OUT can be left floating. Though not required, but for additional protection, a 1k Ω resistor can be tied from XTAL_IN to ground.

LVC MOS Control Pins

All control pins have internal pull-ups or pull-downs; additional resistance is not required but can be added for additional protection. A 1k Ω resistor can be used.

Outputs:

LVPECL Outputs

The unused LVPECL output pair can be left floating. We recommend that there is no trace attached. Both sides of the differential output pair should either be left floating or terminated.

LVDS Outputs

The unused LVDS output pair can be either left floating or terminated with 100 Ω across. If they are left floating, there should be no trace attached.

LVC MOS Outputs

All unused LVC MOS output can be left floating. There should be no trace attached.

Schematic Example

Figure 7 shows an example of ICS8430S10I application schematic. In this example, the device is operated at $V_{DD} = V_{DDO_B} = V_{DDO_CD} = V_{DDO_E} = V_{DDO_REF} = 3.3V$. An 18pF parallel resonant 25MHz crystal is used. The load capacitance $C1 = 18pF$ and $C2 = 18pF$ are recommended for frequency accuracy. Depending on the parasitics of the printed circuit board layout, these values might require a slight adjustment to optimize the frequency accuracy. Crystals with other load capacitance specifications can be used. this will require adjusting $C1$ and $C2$. For this device, the crystal load capacitors are required for proper operation.

As with any high speed analog circuitry, the power supply pins are vulnerable to noise. To achieve optimum jitter performance, power supply isolation is required. The ICS8430S10I provides separate power supplies to isolate from coupling into the internal PLL.

In order to achieve the best possible filtering, it is recommended that the placement of the filter components be on the device side of the PCB as close to the power pins as possible. If space is limited, the 0.1uF capacitor in each power pin filter should be placed on the device side of the PCB and the other components can be placed on the opposite side.

If a specific frequency noise component is known, such as switching power supply frequencies, it is recommended that component values be adjusted and if required, additional filtering be added. Additionally, good general design practices for power plane voltage stability suggests adding bulk capacitances in the local area of all devices.

The schematic example focuses on functional connections and is not configuration specific. Refer to the pin description and functional tables in the datasheet to ensure the logic control inputs are properly set.

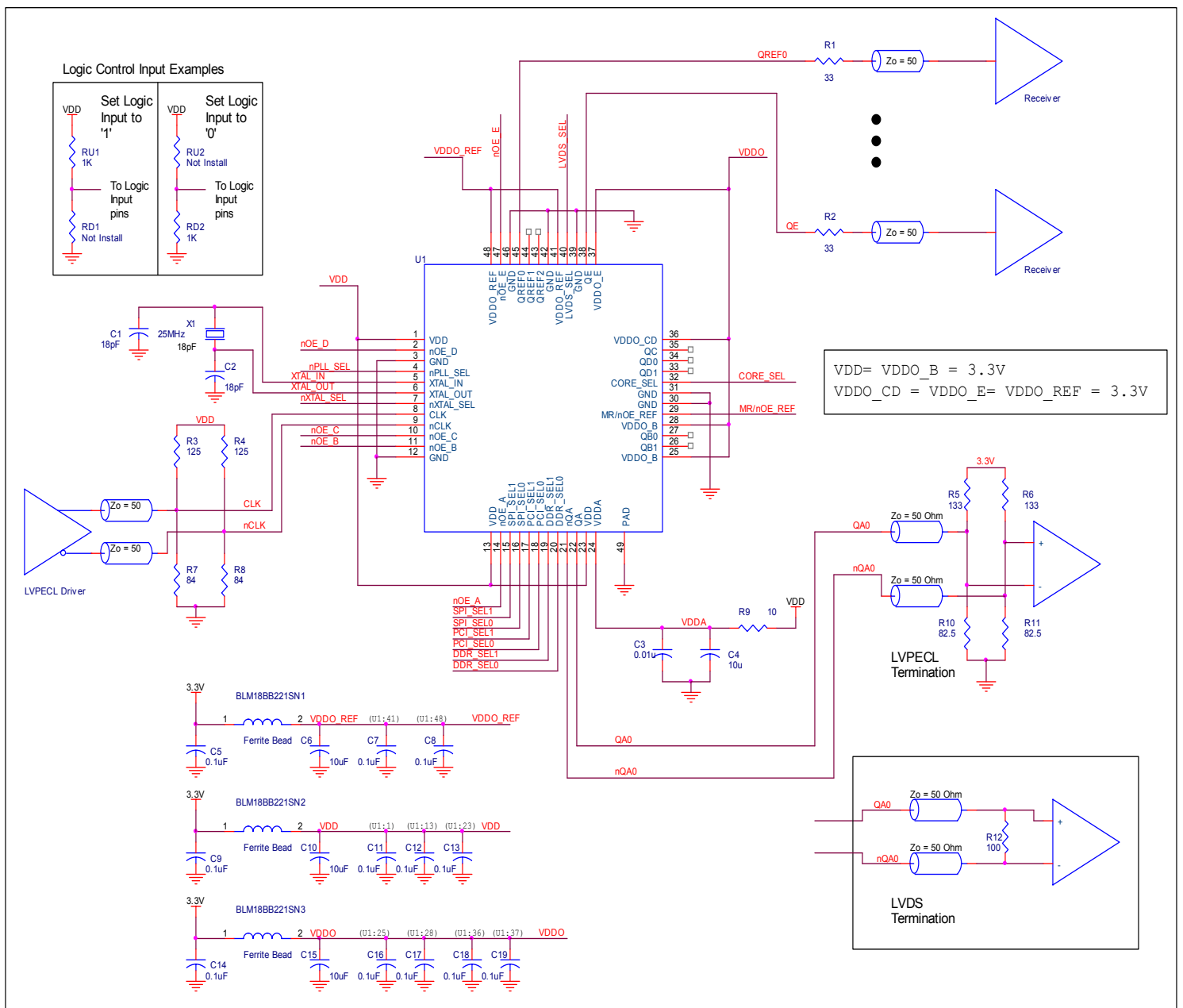

Figure 7. ICS8430S10I Layout Example

Power Considerations (LVCMOS/LVDS Outputs)

This section provides information on power dissipation and junction temperature for the ICS8430S10I. Equations and example calculations are also provided.

1. Power Dissipation.

The total power dissipation for the ICS8430S10I is the sum of the core power plus the power dissipated in the load(s). The following is the power dissipation for $V_{DD} = 3.3V + 5\% = 3.465V$, which gives worst case results.

Core and LVDS Output Power Dissipation

- Power (core, LVDS) = $V_{DD_MAX} * (I_{DD} + I_{DDA}) = 3.465V * (190mA + 24mA) = 741.5mW$

LVCMOS Output Power Dissipation

- Output Impedance R_{OUT} Power Dissipation due to Loading 50Ω to $V_{DDO}/2$
Output Current $I_{OUT} = V_{DDO_MAX} / [2 * (50\Omega + R_{OUT})] = 3.465V / [2 * (50\Omega + 15\Omega)] = 26.65mA$
- Power Dissipation on the R_{OUT} per LVCMOS output
Power (R_{OUT}) = $R_{OUT} * (I_{OUT})^2 = 15\Omega * (26.7mA)^2 = 10.65mW$ per output
- Total Power Dissipation on the R_{OUT}
Total Power (R_{OUT}) = $10.65mW * 9 = 95.88mW$
- Dynamic Power Dissipation at 133.33MHz
Power (125MHz) = $C_{PD} * Frequency * (V_{DDO})^2 = 4pF * 133.33MHz * (3.465V)^2 = 6.4mW$ per output
Total Power (125MHz) = $6.4mW * 6 = 38.4mW$
- Dynamic Power Dissipation at 25MHz
Power (25MHz) = $C_{PD} * Frequency * (V_{DDO})^2 = 4pF * 25MHz * (3.465V)^2 = 1.2mW$ per output
Total Power (25MHz) = $1.2mW * 3 = 3.6mW$

Total Power Dissipation

- Total Power**
= Power (core, LVDS) + Total Power (R_{OUT}) + Total Power (125MHz) + Total Power (25MHz)
= $741.5mW + 95.88mW + 38.4mW + 3.6mW$
= **879.38mW**

2. Junction Temperature.

Junction temperature, T_j , is the temperature at the junction of the bond wire and bond pad directly affects the reliability of the device. The maximum recommended junction temperature is 125°C. Limiting the internal transistor junction temperature, T_j , to 125°C ensures that the bond wire and bond pad temperature remains below 125°C.

The equation for T_j is as follows: $T_j = \theta_{JA} * Pd_total + T_A$

T_j = Junction Temperature

θ_{JA} = Junction-to-Ambient Thermal Resistance

Pd_total = Total Device Power Dissipation (example calculation is in section 1 above)

T_A = Ambient Temperature

In order to calculate junction temperature, the appropriate junction-to-ambient thermal resistance θ_{JA} must be used. Assuming no air flow and a multi-layer board, the appropriate value is 33.1°C/W per Table 7A below.

Therefore, T_j for an ambient temperature of 85°C with all outputs switching is:

$$85^\circ\text{C} + 0.879\text{W} * 33.1^\circ\text{C/W} = 114.1^\circ\text{C}. \text{ This is below the limit of } 125^\circ\text{C}.$$

This calculation is only an example. T_j will obviously vary depending on the number of loaded outputs, supply voltage, air flow and the type of board (multi-layer).

Table 7A. Thermal Resistance θ_{JA} for 48 Lead TQFP, EPAD Forced Convection

θ_{JA} Vs. Air Flow			
Meters per Second	0	1	2.5
Multi-Layer PCB, JEDEC Standard Test Boards	33.1°C/W	27.2°C/W	25.7°C/W

Power Considerations (LVCMOS/LVPECL Outputs)

This section provides information on power dissipation and junction temperature for the ICS8430S10I. Equations and example calculations are also provided.

1. Power Dissipation.

The total power dissipation for the ICS8430S10I is the sum of the core power plus the analog power plus the power dissipated in the load(s). The following is the power dissipation for $V_{DD} = 3.3V + 5\% = 3.465V$, which gives worst case results.

Core and LVPECL Output Power Dissipation

- Power (core)_{MAX} = $V_{DD_MAX} * I_{EE_MAX} = 3.465V * 180mA = \mathbf{623.7mW}$
- Power (output)_{MAX} = **29.4mW/Loaded Output Pair**

LVCMOS Output Power Dissipation

- Output Impedance R_{OUT} Power Dissipation due to Loading 50Ω to $V_{DDO}/2$
Output Current $I_{OUT} = V_{DDO_MAX} / [2 * (50\Omega + R_{OUT})] = 3.465V / [2 * (50\Omega + 15\Omega)] = \mathbf{26.65mA}$
- Power Dissipation on the R_{OUT} per LVCMOS output
Power (R_{OUT}) = $R_{OUT} * (I_{OUT})^2 = 15\Omega * (26.7mA)^2 = \mathbf{10.65mW}$ per output
- Total Power Dissipation on the R_{OUT}
Total Power (R_{OUT}) = $10.65mW * 9 = \mathbf{95.88mW}$
- Dynamic Power Dissipation at 133.33MHz
Power (125MHz) = $C_{PD} * Frequency * (V_{DDO})^2 = 4pF * 133.33MHz * (3.465V)^2 = \mathbf{6.4mW}$ per output
Total Power (125MHz) = $6.4mW * 6 = \mathbf{38.4mW}$
- Dynamic Power Dissipation at 25MHz
Power (25MHz) = $C_{PD} * Frequency * (V_{DDO})^2 = 4pF * 25MHz * (3.465V)^2 = \mathbf{1.2mW}$ per output
Total Power (25MHz) = $1.2mW * 3 = \mathbf{3.6mW}$

Total Power Dissipation

- **Total Power**
= Power (core) + Power (LVPECL output) + Total Power (R_{OUT}) + Total Power (125MHz) + Total Power (25MHz)
= $623.7mW + 29.4mW + 95.88mW + 38.4mW + 3.6mW$
= **790.98mW**

2. Junction Temperature.

Junction temperature, T_j , is the temperature at the junction of the bond wire and bond pad directly affects the reliability of the device. The maximum recommended junction temperature is 125°C. Limiting the internal transistor junction temperature, T_j , to 125°C ensures that the bond wire and bond pad temperature remains below 125°C.

The equation for T_j is as follows: $T_j = \theta_{JA} * Pd_total + T_A$

T_j = Junction Temperature

θ_{JA} = Junction-to-Ambient Thermal Resistance

Pd_total = Total Device Power Dissipation (example calculation is in section 1 above)

T_A = Ambient Temperature

In order to calculate junction temperature, the appropriate junction-to-ambient thermal resistance θ_{JA} must be used. Assuming no air flow and a multi-layer board, the appropriate value is 39.5°C/W per Table 7B below.

Therefore, T_j for an ambient temperature of 85°C with all outputs switching is:

$$85^\circ\text{C} + 0.791\text{W} * 33.1^\circ\text{C/W} = 111.2^\circ\text{C}. \text{ This is below the limit of } 125^\circ\text{C}.$$

This calculation is only an example. T_j will obviously vary depending on the number of loaded outputs, supply voltage, air flow and the type of board (multi-layer).

Table 7B. Thermal Resistance θ_{JA} for 48 Lead TQFP, EPAD Forced Convection

θ_{JA} Vs. Air Flow			
Meters per Second	0	1	2.5
Multi-Layer PCB, JEDEC Standard Test Boards	33.1°C/W	27.2°C/W	25.7°C/W

3. Calculations and Equations.

The purpose of this section is to calculate power dissipation on the LVPECL output pair.

LVPECL output driver circuit and termination are shown in *Figure 8*.

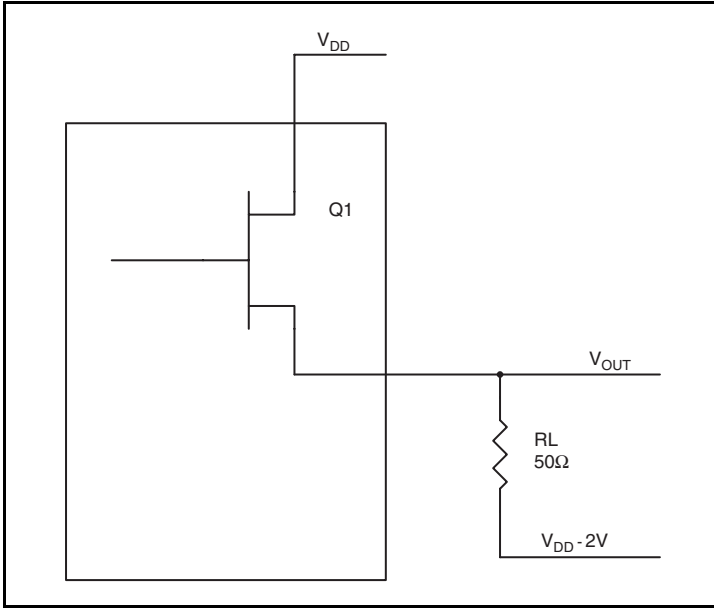

Figure 8. LVPECL Driver Circuit and Termination

To calculate worst case power dissipation into the load, use the following equations which assume a 50Ω load, and a termination voltage of V_{DD} - 2V.

- For logic high, V_{OUT} = V_{OH_MAX} = V_{DD_MAX} - 0.8V
(V_{DD_MAX} - V_{OH_MAX}) = 0.8V
- For logic low, V_{OUT} = V_{OL_MAX} = V_{DD_MAX} - 1.7V
(V_{DD_MAX} - V_{OL_MAX}) = 1.7V

Pd_H is power dissipation when the output drives high.

Pd_L is the power dissipation when the output drives low.

$$Pd_H = [(V_{OH_MAX} - (V_{DD_MAX} - 2V))/R_L] * (V_{DD_MAX} - V_{OH_MAX}) = [(2V - V_{DD_MAX} - V_{OH_MAX})/R_L] * (V_{DD_MAX} - V_{OH_MAX}) = [(2V - 0.8V)/50\Omega] * 0.8V = \mathbf{19.20mW}$$

$$Pd_L = [(V_{OL_MAX} - (V_{DD_MAX} - 2V))/R_L] * (V_{DD_MAX} - V_{OL_MAX}) = [(2V - (V_{DD_MAX} - V_{OL_MAX}))/R_L] * (V_{DD_MAX} - V_{OL_MAX}) = [(2V - 1.7V)/50\Omega] * 1.7V = \mathbf{10.2mW}$$

Total Power Dissipation per output pair = Pd_H + Pd_L = **29.4mW**

Reliability Information

Table 8. θ_{JA} vs. Air Flow Table for a 48 Lead TQFP, EPAD

θ_{JA} vs. Air Flow			
Meters per Second	0	1	2.5
Multi-Layer PCB, JEDEC Standard Test Boards	33.1°C/W	27.2°C/W	25.7°C/W

Transistor Count

The transistor count for ICS8430S10I is: 10,871

Package Outline and Package Dimensions

Package Outline - Y Suffix for 48 Lead TQFP, EPAD

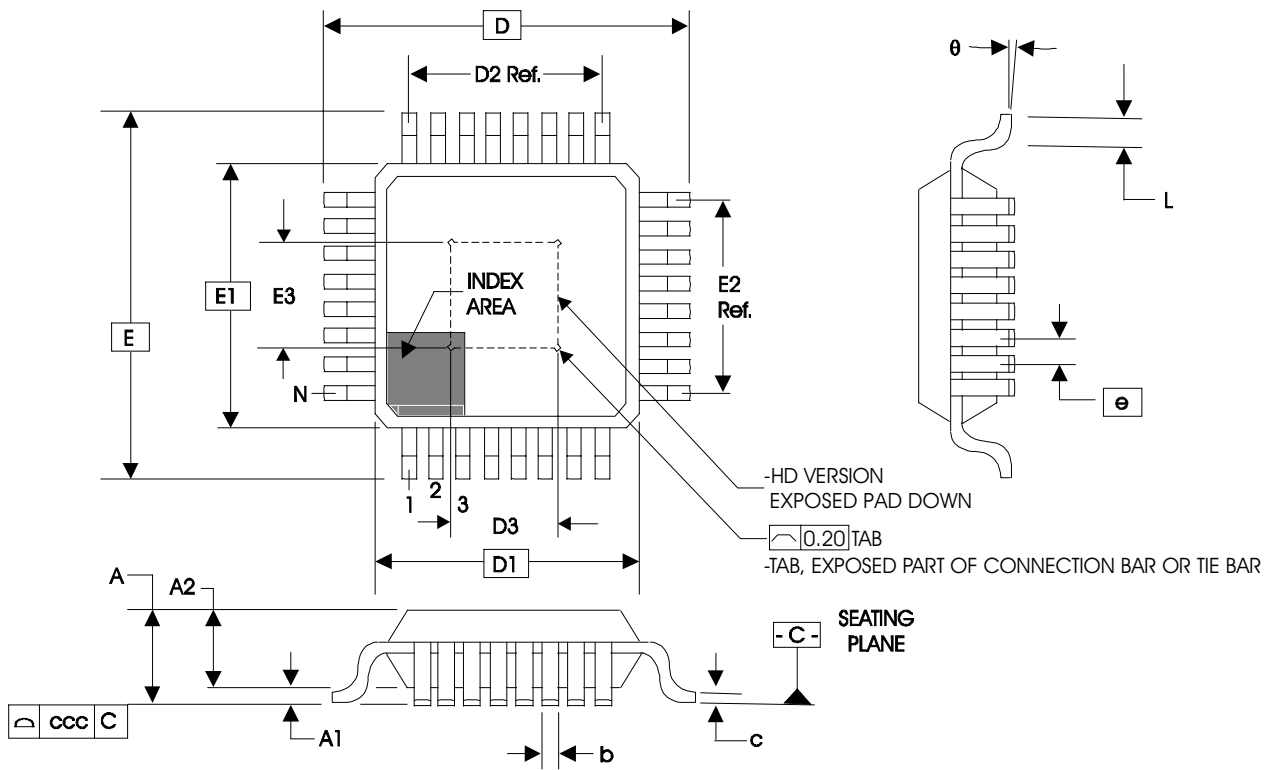

Table 9. Package Dimensions 48L TQFP, EPAD

JEDEC Variation: ABC - HD			
All Dimensions in Millimeters			
Symbol	Minimum	Nominal	Maximum
N		48	
A			1.20
A1	0.05	0.10	0.15
A2	0.95	1.00	1.05
b	0.17	0.22	0.27
c	0.09		0.20
D & E		9.00 Basic	
D1 & E1		7.00 Basic	
D2 & E2		5.50 Ref.	
D3 & E3		3.5	
e		0.5 Basic	
L	0.45	0.60	0.75
θ	0°		7°
ccc			0.08

Reference Document: JEDEC Publication 95, MS-026

Ordering Information

Table 10. Ordering Information

Part/Order Number	Marking	Package	Shipping Packaging	Temperature
8430S10AYILF	ICS430S10AIL	"Lead-Free" 48 TQFP, EPAD	Tray	-40°C to 85°C
8430S10AYILFT	ICS430S10AIL	"Lead-Free" 48 TQFP, EPAD	1000 Tape & Reel	-40°C to 85°C

NOTE: Parts that are ordered with an "LF" suffix to the part number are the Pb-Free configuration and are RoHS compliant.

While the information presented herein has been checked for both accuracy and reliability, Integrated Device Technology (IDT) assumes no responsibility for either its use or for the infringement of any patents or other rights of third parties, which would result from its use. No other circuits, patents, or licenses are implied. This product is intended for use in normal commercial and industrial applications. Any other applications, such as those requiring high reliability or other extraordinary environmental requirements are not recommended without additional processing by IDT. IDT reserves the right to change any circuitry or specifications without notice. IDT does not authorize or warrant any IDT product for use in life support devices or critical medical instruments.

Revision History Sheet

Rev	Table	Page	Description of Change	Date
A		1 17 18	Feature Section - corrected second bullet from <i>Ten LVCMOS/LVTTL...</i> to <i>Nine...</i> Added sentence to end of <i>LVCMOS to XTAL Interface</i> paragraph. Updated Figure 6A & 6 B. Updated Data Sheet format.	9/29/09
B	T4F T9	1 2 8 15 16 17 18 20 27	Features section - corrected Differential Input bullet (deleted HCSL and LVHSTL levels). Block Diagram - corrected naming convention for SPI4_SEL1:0 to SPI_SEL1:0. Differential DC Characteristics Table - corrected VCMR levels from 0.5V min / V_{DD} - 0.85V max to 1.2V min / V_{DD} max. Deleted <i>Power Supply Filtering Technique</i> application note (see Schematic Example). Updated <i>Wiring the Differential Input to Accept Single-ended Levels</i> application note. Corrected <i>Differential Clock Input Interface</i> application note (deleted HCSL and LVHSTL levels). Deleted <i>Crystal Input Interface</i> application note (see Schematic Example). Updated <i>Overdriving the XTAL Interface</i> application note. Updated <i>LVDS Driver Termination</i> application note. Updated <i>Schematic Example</i> application note and diagram. Corrected D3/E3 dimensions. Updated Package Outline.	1/14/11

We've Got Your Timing Solution



6024 Silver Creek Valley Road
San Jose, California 95138

Sales

800-345-7015 (inside USA)
+408-284-8200 (outside USA)
Fax: 408-284-2775
www.IDT.com/go/contactIDT

Technical Support

netcom@idt.com
+480-763-2056

DISCLAIMER Integrated Device Technology, Inc. (IDT) and its subsidiaries reserve the right to modify the products and/or specifications described herein at any time and at IDT's sole discretion. All information in this document, including descriptions of product features and performance, is subject to change without notice. Performance specifications and the operating parameters of the described products are determined in the independent state and are not guaranteed to perform the same way when installed in customer products. The information contained herein is provided without representation or warranty of any kind, whether express or implied, including, but not limited to, the suitability of IDT's products for any particular purpose, an implied warranty of merchantability, or non-infringement of the intellectual property rights of others. This document is presented only as a guide and does not convey any license under intellectual property rights of IDT or any third parties.

IDT's products are not intended for use in life support systems or similar devices where the failure or malfunction of an IDT product can be reasonably expected to significantly affect the health or safety of users. Anyone using an IDT product in such a manner does so at their own risk, absent an express, written agreement by IDT.

Integrated Device Technology, IDT and the IDT logo are registered trademarks of IDT. Other trademarks and service marks used herein, including protected names, logos and designs, are the property of IDT or their respective third party owners.

Copyright 2011. All rights reserved.