



# ICS843011

## FEMTOCLOCKS™ CRYSTAL-TO-3.3V LVPECL CLOCK GENERATOR

### GENERAL DESCRIPTION

The ICS843011 is a Fibre Channel Clock Generator. The ICS843011 uses a 26.5625MHz crystal to synthesize 106.25MHz or a 25MHz crystal to synthesize 100MHz. The ICS843011 has excellent <1ps phase jitter performance, over the 637kHz – 10MHz integration range. The ICS843011 is packaged in a small 8-pin TSSOP, making it ideal for use in systems with limited board space.

### FEATURES

- One differential 3.3V LVPECL output
- Crystal oscillator interface designed for 26.5625MHz 18pF parallel resonant crystal
- Output frequency: 106.25MHz or 100MHz
- VCO range: 560MHz - 680MHz
- RMS phase jitter @ 100MHz, using a 25MHz crystal (637kHz - 10MHz): 0.80ps (typical)
- RMS phase noise at 106.25MHz

Phase noise:

Offset	Noise Power
100Hz .....	-92.8 dBc/Hz
1kHz .....	-119.6 dBc/Hz
10kHz .....	-129.5 dBc/Hz
100kHz .....	-130.5 dBc/Hz

- 3.3V operating supply
- Available in both standard (RoHS 5) and lead-free (RoHS 6) packages
- -40°C to 85°C ambient operating temperature

### FREQUENCY TABLE

Crystal (MHz)	Output Frequency (MHz)
26.5625	106.25
25	100

### BLOCK DIAGRAM

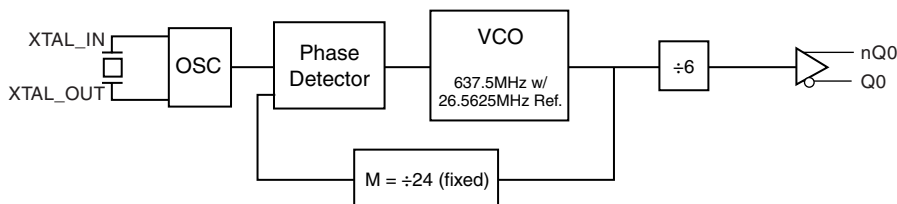

### PIN ASSIGNMENT

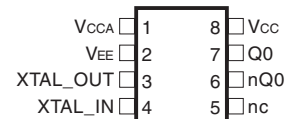

### ICS843011

#### 8-Lead TSSOP

4.40mm x 3.0mm x 0.925mm package body

#### G Package

Top View



# ICS843011

## FEMTOCLOCKS™ CRYSTAL-TO-3.3V LVPECL CLOCK GENERATOR

**TABLE 1. PIN DESCRIPTIONS**

Number	Name	Type	Description
1	V <sub>CCA</sub>	Power	Analog supply pin.
2	V <sub>EE</sub>	Power	Negative supply pin.
3, 4	XTAL_OUT, XTAL_IN	Input	Crystal oscillator interface. XTAL_IN is the input, XTAL_OUT is the output.
5	nc	Unused	No connect.
6, 7	nQ0, Q0	Output	Differential clock outputs. LVPECL interface levels.
8	V <sub>CC</sub>	Power	Core supply pin.

**TABLE 2. PIN CHARACTERISTICS**

Symbol	Parameter	Test Conditions	Minimum	Typical	Maximum	Units
C <sub>IN</sub>	Input Capacitance			4		pF



# ICS843011

## FEMTOCLOCKS™ CRYSTAL-TO-3.3V LVPECL CLOCK GENERATOR

### ABSOLUTE MAXIMUM RATINGS

Supply Voltage, $V_{CC}$	4.6V
Inputs, $V_i$	-0.5V to $V_{CC} + 0.5V$
Outputs, $I_o$	
Continuous Current	50mA
Surge Current	100mA
Package Thermal Impedance, $\theta_{JA}$	101.7°C/W (0 mps)
Storage Temperature, $T_{STG}$	-65°C to 150°C

NOTE: Stresses beyond those listed under Absolute Maximum Ratings may cause permanent damage to the device. These ratings are stress specifications only. Functional operation of product at these conditions or any conditions beyond those listed in the *DC Characteristics* or *AC Characteristics* is not implied. Exposure to absolute maximum rating conditions for extended periods may affect product reliability.

**TABLE 3A. POWER SUPPLY DC CHARACTERISTICS,  $V_{CC} = 3.3V \pm 5\%$ ,  $T_A = -40^\circ C$  TO  $85^\circ C$**

Symbol	Parameter	Test Conditions	Minimum	Typical	Maximum	Units
$V_{CC}$	Core Supply Voltage		3.135	3.3	3.465	V
$V_{CCA}$	Analog Supply Voltage		3.135	3.3	3.465	V
$I_{CCA}$	Analog Supply Current	included in $I_{EE}$			12	mA
$I_{EE}$	Power Supply Current				93	mA

**TABLE 3B. LVPECL DC CHARACTERISTICS,  $V_{CC} = 3.3V \pm 5\%$ ,  $T_A = -40^\circ C$  TO  $85^\circ C$**

Symbol	Parameter	Test Conditions	Minimum	Typical	Maximum	Units
$V_{OH}$	Output High Voltage; NOTE 1		$V_{CC} - 1.4$		$V_{CC} - 0.9$	V
$V_{OL}$	Output Low Voltage; NOTE 1		$V_{CC} - 2.0$		$V_{CC} - 1.7$	V
$V_{SWING}$	Peak-to-Peak Output Voltage Swing		0.6		1.0	V

NOTE 1: Outputs terminated with  $50\Omega$  to  $V_{CC} - 2V$ .

**TABLE 4. CRYSTAL CHARACTERISTICS**

Parameter	Test Conditions	Minimum	Typical	Maximum	Units
Mode of Oscillation		Fundamental			
Frequency		25		26.5625	MHz
Equivalent Series Resistance (ESR)				50	$\Omega$
Shunt Capacitance				7	pF

**TABLE 5. AC CHARACTERISTICS,  $V_{CC} = 3.3V \pm 5\%$ ,  $T_A = -40^\circ C$  TO  $85^\circ C$**

Symbol	Parameter	Test Conditions	Minimum	Typical	Maximum	Units
$F_{OUT}$	Output Frequency		93.33		113.33	MHz
$f_{jit}(\emptyset)$	RMS Phase Jitter (Random); NOTE 1	106.25MHz; Integration Range: 637KHz - 10MHz		0.80		ps
		100MHz; Integration Range: 637KHz - 10MHz		0.80		ps
$t_R / t_F$	Output Rise/Fall Time	20% to 80%	300		600	ps
odc	Output Duty Cycle		48		52	%

NOTE 1: Please refer to the Phase Noise Plot.



### TYPICAL PHASE NOISE AT 100MHz

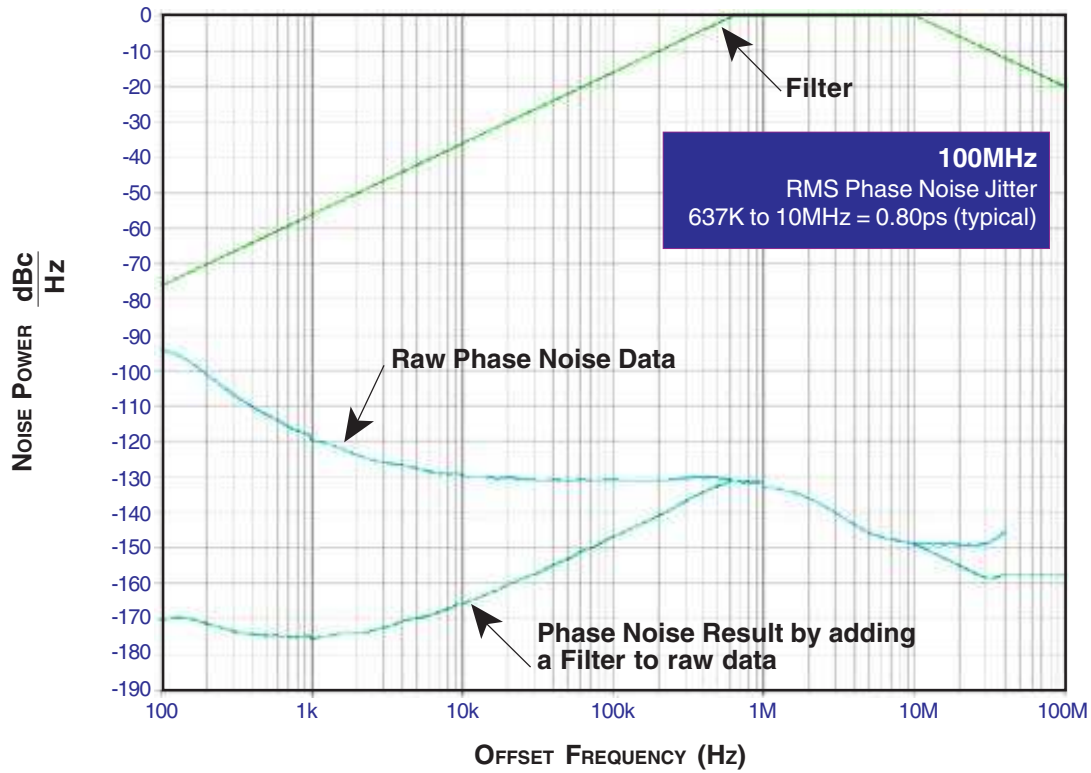

### TYPICAL PHASE NOISE AT 106.25MHz

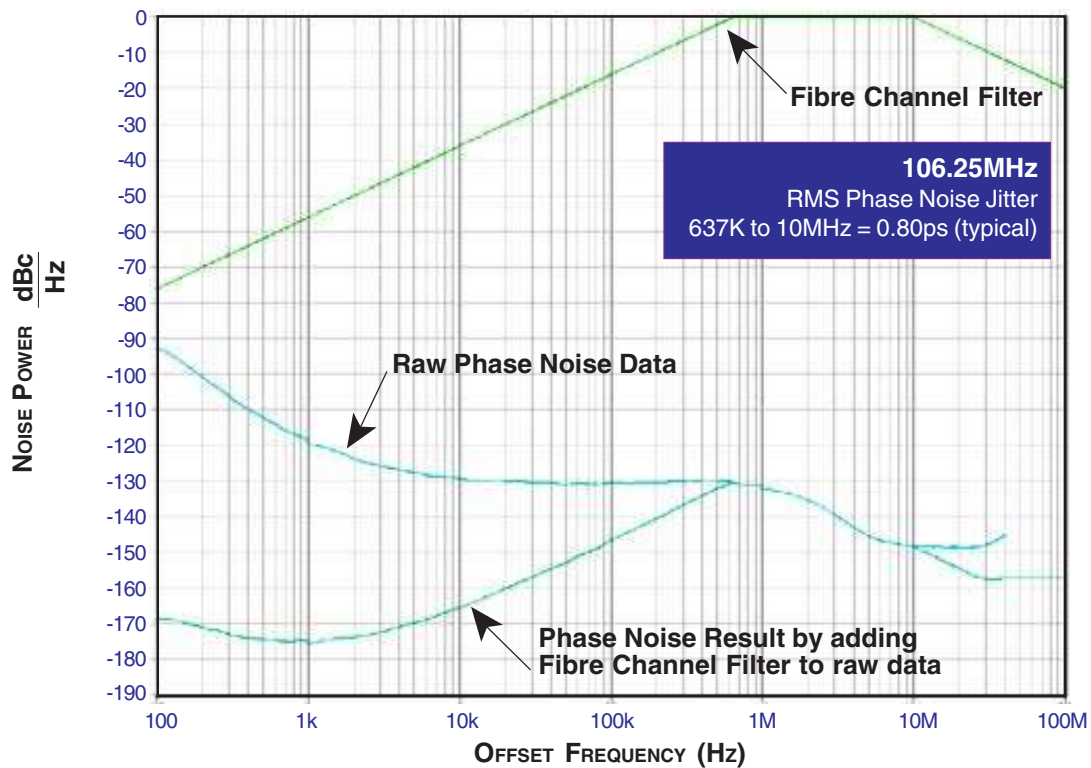

**PARAMETER MEASUREMENT INFORMATION**

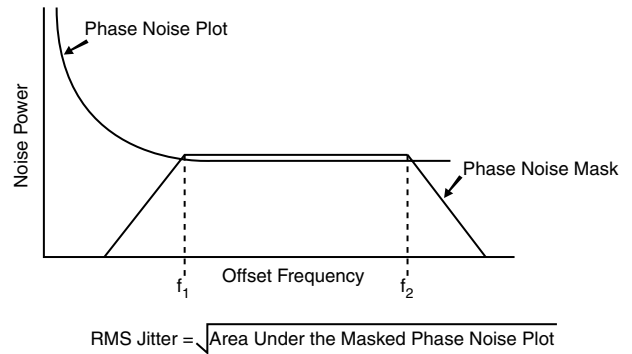
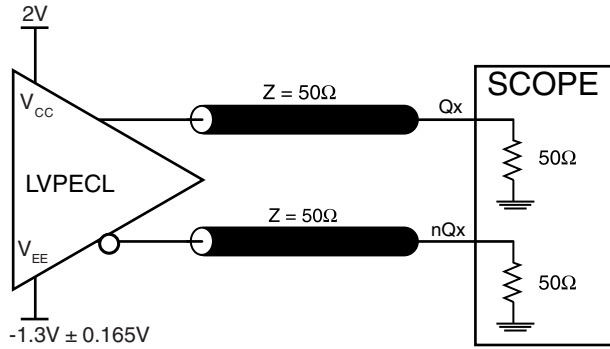

**3.3V OUTPUT LOAD AC TEST CIRCUIT**

**RMS PHASE JITTER**

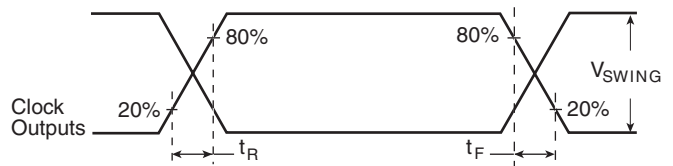
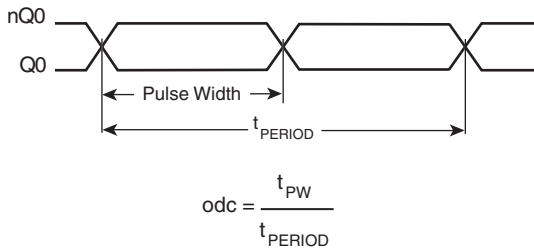

**OUTPUT DUTY CYCLE/PULSE WIDTH/PERIOD**

**OUTPUT RISE/FALL TIME**

## APPLICATION INFORMATION

### POWER SUPPLY FILTERING TECHNIQUES

As in any high speed analog circuitry, the power supply pins are vulnerable to random noise. The ICS843011 provides separate power supplies to isolate any high switching noise from the outputs to the internal PLL.  $V_{CC}$ , and  $V_{CCA}$  should be individually connected to the power supply plane through vias, and bypass capacitors should be used for each pin. To achieve optimum jitter performance, power supply isolation is required. *Figure 1* illustrates how a  $10\Omega$  resistor along with a  $10\mu\text{F}$  and a  $.01\mu\text{F}$  bypass capacitor should be connected to each  $V_{CCA}$  pin.

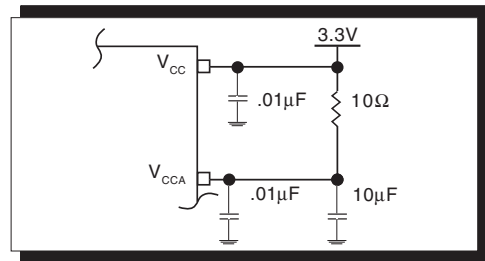
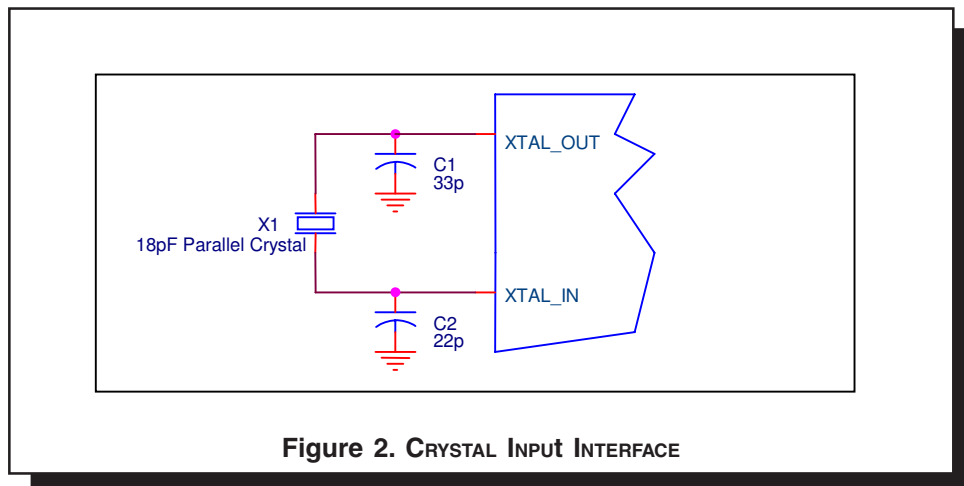

**FIGURE 1. POWER SUPPLY FILTERING**

### CRYSTAL INPUT INTERFACE

The ICS843011 has been characterized with 18pF parallel resonant crystals. The capacitor values, C1 and C2, shown in *Figure 2* below were determined using a 26.5625MHz, 18pF par-

allel resonant crystal and were chosen to minimize the ppm error. The optimum C1 and C2 values can be slightly adjusted for different board layouts.



**Figure 2. CRYSTAL INPUT INTERFACE**

### APPLICATION SCHEMATIC

Figure 3A shows a schematic example of the ICS843011. An example of LVPECL termination is shown in this schematic. Additional LVPECL termination approaches are shown in the LVPECL Termination Application Note. In this example, an 18 pF parallel resonant 26.5625MHz crystal is

used for generating 106.25MHz output frequency. The C1 = 27pF and C2 = 33pF are recommended for frequency accuracy. For different board layout, the C1 and C2 values may be slightly adjusted for optimizing frequency accuracy.

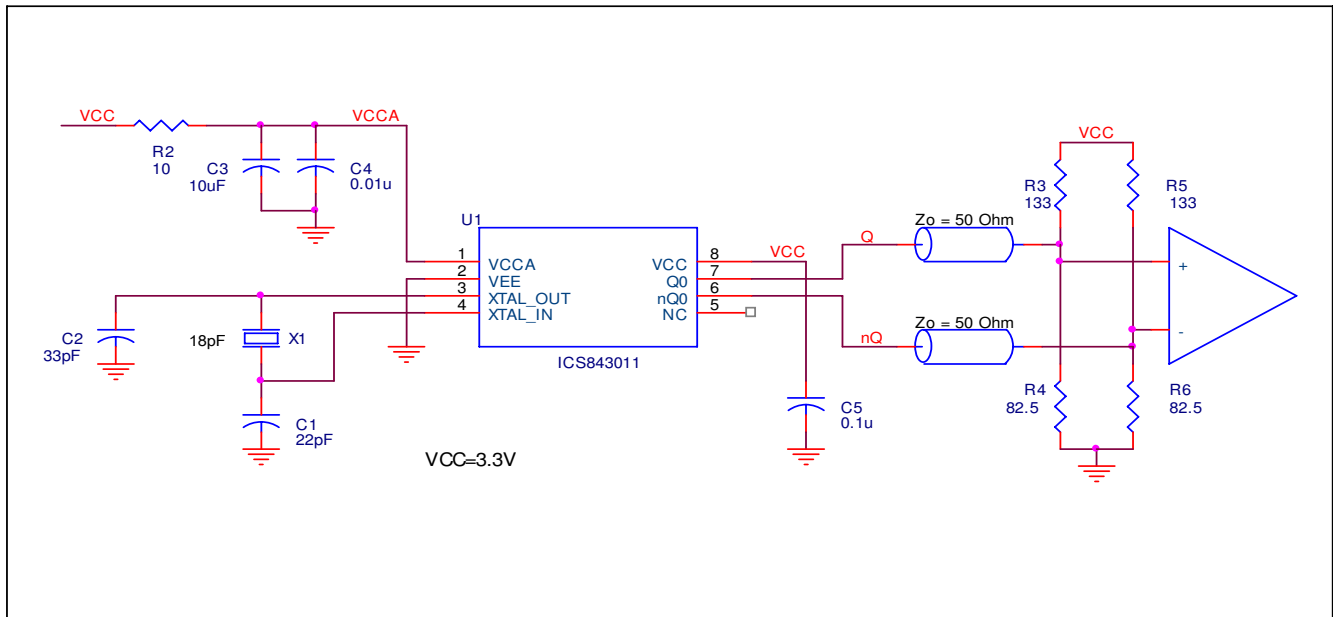

FIGURE 3A. ICS843011 SCHEMATIC EXAMPLE

### PC BOARD LAYOUT EXAMPLE

Figure 3B shows an example of ICS843011 P.C. board layout. The crystal X1 footprint shown in this example allows installation of either surface mount HC49S or through-hole HC49 package. The footprints of other components in

this example are listed in the Table 6. There should be at least one decoupling capacitor per power pin. The decoupling capacitors should be located as close as possible to the power pins. The layout assumes that the board has clean analog power ground plane.

TABLE 6. FOOTPRINT TABLE

Reference	Size
C1, C2	0402
C3	0805
C4, C5	0603
R2	0603

NOTE: Table 6, lists component sizes shown in this layout example.

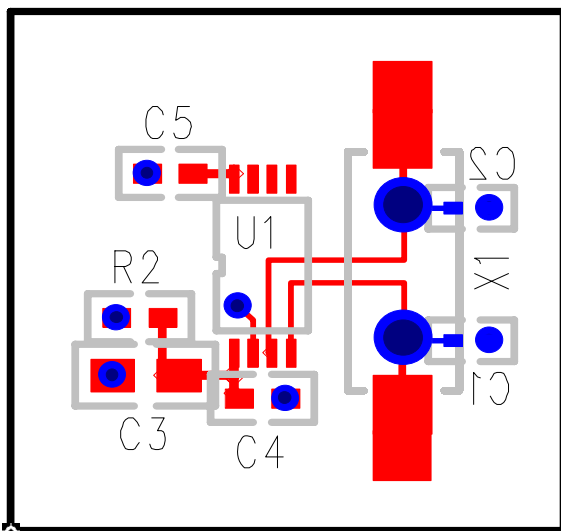

FIGURE 3B. ICS843011 PC BOARD LAYOUT EXAMPLE



## POWER CONSIDERATIONS

This section provides information on power dissipation and junction temperature for the ICS843011. Equations and example calculations are also provided.

### 1. Power Dissipation.

The total power dissipation for the ICS843011 is the sum of the core power plus the power dissipated in the load(s). The following is the power dissipation for  $V_{CC} = 3.3V + 5\% = 3.465V$ , which gives worst case results.

**NOTE:** Please refer to Section 3 for details on calculating power dissipated in the load.

- Power (core)<sub>MAX</sub> =  $V_{CC\_MAX} * I_{EE\_MAX} = 3.465V * 93mA = \mathbf{322.2mW}$
- Power (outputs)<sub>MAX</sub> = **30mW/Loaded Output pair**

**Total Power**<sub>MAX</sub> (3.465V, with all outputs switching) = 322.2mW + 30mW = **352.2mW**

### 2. Junction Temperature.

Junction temperature, T<sub>j</sub>, is the temperature at the junction of the bond wire and bond pad and directly affects the reliability of the device. The maximum recommended junction temperature for the devices is 125°C.

The equation for T<sub>j</sub> is as follows:  $T_j = \theta_{JA} * Pd\_total + T_A$

T<sub>j</sub> = Junction Temperature

$\theta_{JA}$  = Junction-to-Ambient Thermal Resistance

Pd<sub>total</sub> = Total Device Power Dissipation (example calculation is in section 1 above)

T<sub>A</sub> = Ambient Temperature

In order to calculate junction temperature, the appropriate junction-to-ambient thermal resistance  $\theta_{JA}$  must be used. Assuming a moderate air flow of 1 meter per second and a multi-layer board, the appropriate value is 90.5°C/W per Table 6 below.

Therefore, T<sub>j</sub> for an ambient temperature of 85°C with all outputs switching is:

$85^\circ C + 0.352W * 90.5^\circ C/W = 116.9^\circ C$ . This is below the limit of 125°C.

This calculation is only an example. T<sub>j</sub> will obviously vary depending on the number of loaded outputs, supply voltage, air flow, and the type of board (single layer or multi-layer).

**TABLE 6. THERMAL RESISTANCE  $\theta_{JA}$  FOR 8-PIN TSSOP, FORCED CONVECTION**

$\theta_{JA}$ by Velocity (Meters per Second)			
	0	1	2.5
Multi-Layer PCB, JEDEC Standard Test Boards	101.7°C/W	90.5°C/W	89.8°C/W

### 3. Calculations and Equations.

The purpose of this section is to derive the power dissipated into the load.

LVPECL output driver circuit and termination are shown in *Figure 4*.

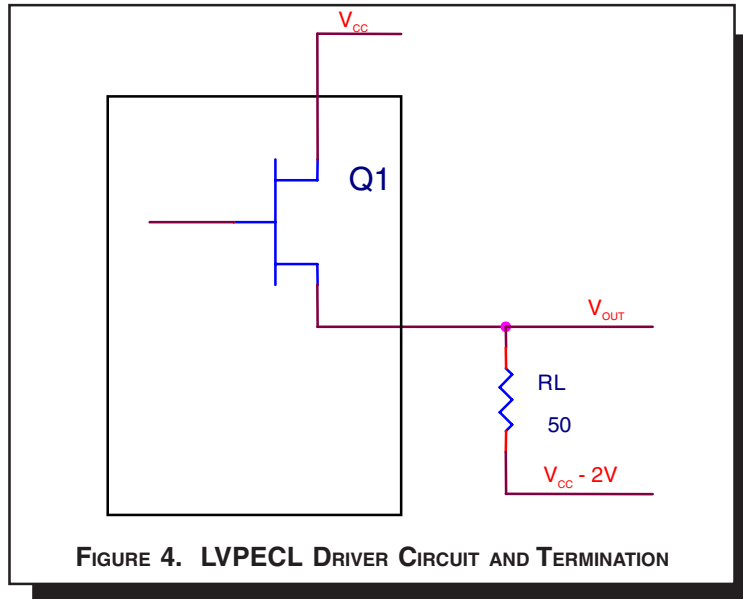

**FIGURE 4. LVPECL DRIVER CIRCUIT AND TERMINATION**

To calculate worst case power dissipation into the load, use the following equations which assume a 50Ω load, and a termination voltage of  $V_{CC} - 2V$ .

- For logic high,  $V_{OUT} = V_{OH\_MAX} = V_{CC\_MAX} - 0.9V$

$$(V_{CC\_MAX} - V_{OH\_MAX}) = 0.9V$$

- For logic low,  $V_{OUT} = V_{OL\_MAX} = V_{CC\_MAX} - 1.7V$

$$(V_{CC\_MAX} - V_{OL\_MAX}) = 1.7V$$

Pd\_H is power dissipation when the output drives high.

Pd\_L is the power dissipation when the output drives low.

$$Pd\_H = [(V_{OH\_MAX} - (V_{CC\_MAX} - 2V))/R_L] * (V_{CC\_MAX} - V_{OH\_MAX}) = [(2V - (V_{CC\_MAX} - V_{OH\_MAX}))/R_L] * (V_{CC\_MAX} - V_{OH\_MAX}) = [(2V - 0.9V)/50\Omega] * 0.9V = 19.8mW$$

$$Pd\_L = [(V_{OL\_MAX} - (V_{CC\_MAX} - 2V))/R_L] * (V_{CC\_MAX} - V_{OL\_MAX}) = [(2V - (V_{CC\_MAX} - V_{OL\_MAX}))/R_L] * (V_{CC\_MAX} - V_{OL\_MAX}) = [(2V - 1.7V)/50\Omega] * 1.7V = 10.2mW$$

Total Power Dissipation per output pair = Pd\_H + Pd\_L = **30mW**



## RELIABILITY INFORMATION

TABLE 7.  $\theta_{JA}$  VS. AIR FLOW TABLE FOR 8 LEAD TSSOP

$\theta_{JA}$ by Velocity (Meters per Second)			
	0	1	2.5
Multi-Layer PCB, JEDEC Standard Test Boards	101.7°C/W	90.5°C/W	89.8°C/W

### TRANSISTOR COUNT

The transistor count for ICS843011 is: 2436

PACKAGE OUTLINE - G SUFFIX FOR 8 LEAD TSSOP

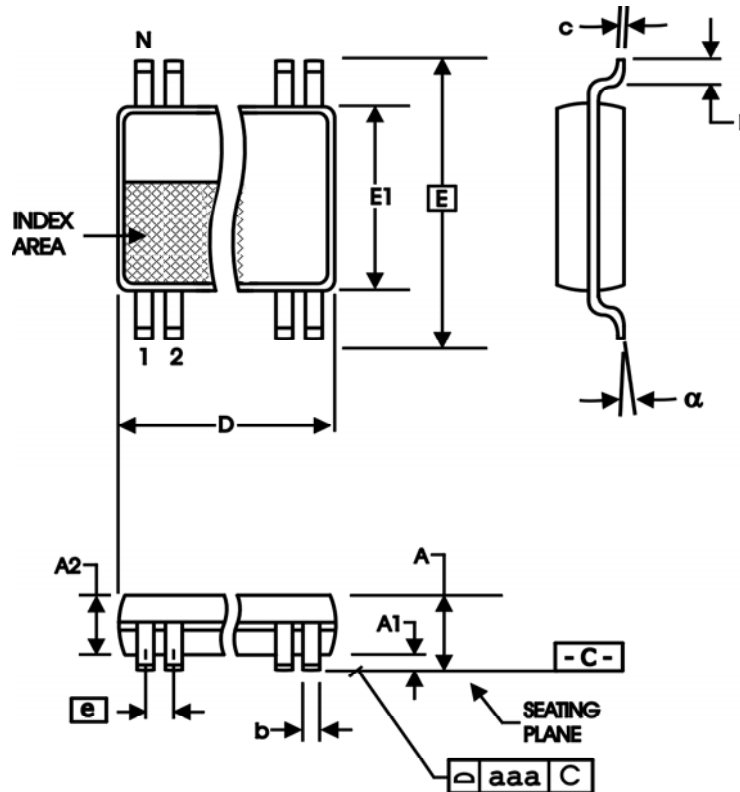

TABLE 8. PACKAGE DIMENSIONS

SYMBOL	Millimeters	
	Minimum	Maximum
N	8	
A	--	1.20
A1	0.05	0.15
A2	0.80	1.05
b	0.19	0.30
c	0.09	0.20
D	2.90	3.10
E	6.40 BASIC	
E1	4.30	4.50
e	0.65 BASIC	
L	0.45	0.75
α	0°	8°
aaa	--	0.10

Reference Document: JEDEC Publication 95, MO-153



**ICS843011**  
**FEMTOCLOCKS™ CRYSTAL-TO-**  
**3.3V LVPECL CLOCK GENERATOR**

**TABLE 9. ORDERING INFORMATION**

<b>Part/Order Number</b>	<b>Marking</b>	<b>Package</b>	<b>Shipping Package</b>	<b>Temperature</b>
843011AG	3011A	8 lead TSSOP	tube	-40°C to 85°C
843011AGT	3011A	8 lead TSSOP	2500 tape & reel	-40°C to 85°C
843011AGLF	011AL	8 lead "Lead-Free" TSSOP	tube	-40°C to 85°C
843011AGLFT	011AL	8 lead "Lead-Free" TSSOP	2500 tape & reel	-40°C to 85°C

NOTE: Parts that are ordered with an "LF" suffix to the part number are the Pb-Free configuration and are RoHS compliant.

While the information presented herein has been checked for both accuracy and reliability, Integrated Device Technology, Inc. (IDT) assumes no responsibility for either its use or for infringement of any patents or other rights of third parties, which would result from its use. No other circuits, patents, or licenses are implied. This product is intended for use in normal commercial and industrial applications. Any other applications such as those requiring high reliability, or other extraordinary environmental requirements are not recommended without additional processing by IDT. IDT reserves the right to change any circuitry or specifications without notice. IDT does not authorize or warrant any IDT product for use in life support devices or critical medical instruments.



**ICS843011**  
**FEMTOCLOCKS™ CRYSTAL-TO-**  
**3.3V LVPECL CLOCK GENERATOR**

<b>REVISION HISTORY SHEET</b>				
<b>Rev</b>	<b>Table</b>	<b>Page</b>	<b>Description of Change</b>	<b>Date</b>
B	3A	3	Power Supply DC Characteristics Table - added $I_{CCA}$ spec.	8/23/04
B	T9	12	Ordering Information Table - corrected count from 154 to 100.	10/13/04
B	T9	12	Ordering Information Table - corrected Lead-Free marking from 3011AL to 011AL.	10/20/04
B		1	Changed ambient operating temperature bullet from -30°C to 85°C to -40°C to 85°C and throughout data sheet.	12/10/04
		6	Crystal Input Interface - changed capacitor C2 value from 27p to 22p.	
		7	Application Schematic - corrected schematic to reflect Crystal Input Interface change.	
B	T9	12	Ordering Information Table - deleted tube count in Shipping Packaging column.	1/26/07
B	T9	12	Updated datasheet's header/footer with IDT from ICS.	7/26/10
		12	Removed ICS prefix from Part/Order Number column.	
		14	Added Contact Page.	



**ICS843011**  
FEMTOCLOCKS™ CRYSTAL-TO-  
3.3V LVPECL CLOCK GENERATOR

---

**We've Got Your Timing Solution.**



6024 Silver Creek Valley Road  
San Jose, CA 95138

**Sales**  
800-345-7015 (inside USA)  
+408-284-8200 (outside USA)  
Fax: 408-284-2775

**Tech Support**  
netcom@idt.com