

General Description

The ICS843004I is a 4 output LVPECL synthesizer optimized to generate Fibre Channel reference clock frequencies. Using a 26.5625MHz 18pF parallel resonant crystal, the following frequencies can be generated based on the two frequency select pins (F_SEL[1:0]): 212.5MHz, 187.5MHz, 159.375MHz, 156.25MHz, 106.25MHz, and 53.125MHz. The ICS843004I uses IDT's 3rd generation low phase noise VCO technology and can achieve 1ps or lower typical rms phase jitter, easily meeting Fibre Channel jitter requirements. The ICS843004I is packaged in a small 24-pin TSSOP package.

Features

- Four 3.3V differential LVPECL output pairs
- Selectable crystal oscillator interface or LVCMOS/LVTTL single-ended clock input
- Supports the following output frequencies: 212.5MHz, 187.5MHz, 159.375MHz, 156.25MHz, 106.25MHz, 53.125MHz
- VCO range: 560MHz – 680MHz
- Output skew: 50ps (maximum)
- RMS phase jitter @ 212.5MHz, using a 26.5625MHz crystal (2.55MHz – 20MHz): 0.47ps (typical)
- Full 3.3V or 2.5V supply modes
- -40°C to 85°C ambient operating temperature
- Available in both standard (RoHS 5) and lead-free (RoHS 6) packages

Bank A Frequency Table

Inputs				N Div. Value	M/N Div. Value	Output Frequency (MHz)
Input Frequency (MHz)	F_SEL1	F_SEL0	M Div. Value			
26.5625	0	0	24	3	8	212.5
26.5625	0	1	24	4	6	159.375
26.5625	1	0	24	6	4	106.25
26.5625	1	1	24	12	2	53.125
26.04166	0	1	24	4	6	156.25
23.4375	0	0	24	3	8	187.5

Block Diagram

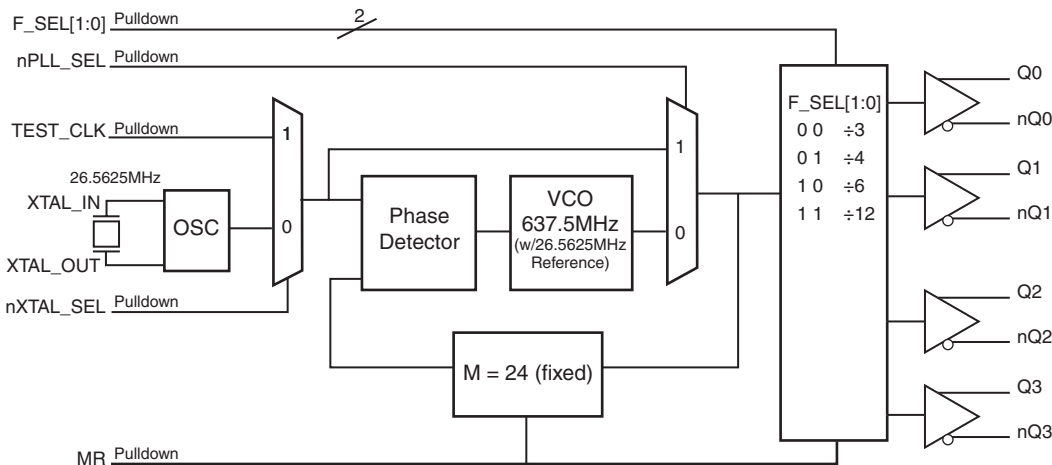

Pin Assignment

nQ1	1	24	nQ2
Q1	2	23	Q2
V _{CC0}	3	22	V _{CC0}
Q0	4	21	Q3
nQ0	5	20	nQ3
MR	6	19	VEE
nPLL_SEL	7	18	nc
nc	8	17	nXTAL_SEL
V _{CCA}	9	16	TEST_CLK
F_SEL0	10	15	VEE
V _{CC}	11	14	XTAL_IN
F_SEL1	12	13	XTAL_OUT

ICS843004I
24-Lead TSSOP
4.4mm x 7.8mm x 0.925mm
package body
G Package
Top View

Table 1. Pin Descriptions

Number	Name	Type		Description
1, 2	nQ1, Q1	Output		Differential output pair. LVPECL interface levels.
3, 22	V _{CCO}	Power		Output supply pins.
4, 5	Q0, nQ0	Output		Differential output pair. LVPECL interface levels.
6	MR	Input	Pulldown	Active HIGH Master Reset. When logic HIGH, the internal dividers are reset causing the true outputs Qx to go low and the inverted outputs nQx to go high. When logic LOW, the internal dividers and the outputs are enabled. LVCMOS/LVTTL interface levels.
7	nPLL_SEL	Input	Pulldown	Selects between the PLL and TEST_CLK as input to the dividers. When LOW, selects PLL (PLL Enable). When HIGH, deselects the reference clock (PLL Bypass). LVCMOS/LVTTL interface levels.
8, 18	nc	Unused		No connect.
9	V _{CCA}	Power		Analog supply pin.
10, 12	F_SEL0, F_SEL1	Input	Pulldown	Frequency select pins. LVCMOS/LVTTL interface levels.
11	V _{CC}	Power		Core supply pin.
13, 14	XTAL_OUT, XTAL_IN	Input		Parallel resonant crystal interface. XTAL_OUT is the output, XTAL_IN is the input.
15, 19	V _{EE}	Power		Negative supply pins.
16	TEST_CLK	Input	Pulldown	Single-ended clock input. LVCMOS/LVTTL interface levels.
17	nXTAL_SEL	Input	Pulldown	Selects between the single-ended TEST_CLK or crystal interface as the PLL reference source. When HIGH, selects TEST_CLK. When LOW, selects XTAL. LVCMOS/LVTTL interface levels.
20, 21	nQ3, Q3	Output		Differential output pair. LVPECL interface levels.
23, 24	Q2, nQ2	Output		Differential output pair. LVPECL interface levels.

NOTE: *Pulldown* refers to internal input resistors. See Table 2, *Pin Characteristics*, for typical values.

Table 2. Pin Characteristics

Symbol	Parameter	Test Conditions	Minimum	Typical	Maximum	Units
C _{IN}	Input Capacitance			4		pF
R _{PULLDOWN}	Input Pulldown Resistor			51		kΩ

Absolute Maximum Ratings

NOTE: Stresses beyond those listed under *Absolute Maximum Ratings* may cause permanent damage to the device. These ratings are stress specifications only. Functional operation of product at these conditions or any conditions beyond those listed in the *DC Characteristics* or *AC Characteristics* is not implied. Exposure to absolute maximum rating conditions for extended periods may affect product reliability.

Item	Rating
Supply Voltage, V_{CC}	4.6V
Inputs, V_I XTAL_IN Other Inputs	0V to V_{CC} -0.5V to $V_{CC} + 0.5V$
Outputs, I_O (LVPECL) Continuous Current Surge Current	50mA 100mA
Package Thermal Impedance, θ_{JA}	70°C/W (0 mps)
Storage Temperature, T_{STG}	-65°C to 150°C

DC Electrical Characteristics

Table 3A. Power Supply DC Characteristics, $V_{CC} = V_{CCA} = V_{CCO} = 3.3V \pm 5\%$, $V_{EE} = 0V$, $T_A = -40^\circ C$ to $85^\circ C$

Symbol	Parameter	Test Conditions	Minimum	Typical	Maximum	Units
V_{CC}	Core Supply Voltage		3.135	3.3	3.465	V
V_{CCA}	Analog Supply Voltage		3.135	3.3	3.465	V
V_{CCO}	Output Supply Voltage		3.135	3.3	3.465	V
I_{EE}	Power Supply Current				130	mA
I_{CCA}	Analog Supply Current	Included in I_{EE}			15	mA

Table 3B. Power Supply DC Characteristics, $V_{CC} = V_{CCA} = V_{CCO} = 2.5V \pm 5\%$, $V_{EE} = 0V$, $T_A = -40^\circ C$ to $85^\circ C$

Symbol	Parameter	Test Conditions	Minimum	Typical	Maximum	Units
V_{CC}	Core Supply Voltage		2.375	2.5	2.625	V
V_{CCA}	Analog Supply Voltage		2.375	2.5	2.625	V
V_{CCO}	Output Supply Voltage		2.375	2.5	2.625	V
I_{EE}	Power Supply Current				120	mA
I_{CCA}	Analog Supply Current	Included in I_{EE}			12	mA

Table 3C. LVCMOS/LVTTL DC Characteristics, $V_{CC} = V_{CCA} = V_{CCO} = 3.3V \pm 5\%$ or $2.5V \pm 5\%$, $V_{EE} = 0V$, $T_A = -40^\circ C$ to $85^\circ C$

Symbol	Parameter		Test Conditions	Minimum	Typical	Maximum	Units
V_{IH}	Input High Voltage		$V_{CC} = 3.3V$	2		$V_{CC} + 0.3$	V
			$V_{CC} = 2.5V$	1.7		$V_{CC} + 0.3$	V
V_{IL}	Input Low Voltage		$V_{CC} = 3.3V$	-0.3		0.8	V
			$V_{CC} = 2.5V$	-0.3		0.7	V
I_{IH}	Input High Current	TEST_CLK, MR, F_SEL[0:1], nPLL_SEL, nXTAL_SEL	$V_{CC} = V_{IN} = 3.465V$ or $2.625V$			150	μA
I_{IL}	Input Low Current	TEST_CLK, MR, F_SEL[0:1], nPLL_SEL, nXTAL_SEL	$V_{CC} = 3.465V$ or $2.625V$, $V_{IN} = 0V$	-5			μA

Table 3D. LVPECL DC Characteristics, $V_{CC} = V_{CCA} = V_{CCO} = 3.3V \pm 5\%$ or $2.5V \pm 5\%$, $V_{EE} = 0V$, $T_A = -40^\circ C$ to $85^\circ C$

Symbol	Parameter	Test Conditions	Minimum	Typical	Maximum	Units
V_{OH}	Output High Current; NOTE 1		$V_{CCO} - 1.4$		$V_{CCO} - 0.9$	μA
V_{OL}	Output Low Current; NOTE 1		$V_{CCO} - 2.0$		$V_{CCO} - 1.7$	μA
V_{SWING}	Peak-to-Peak Output Voltage Swing		0.6		1.0	V

NOTE 1: Outputs termination with 50Ω to $V_{CCO} - 2V$.**Table 4. Crystal Characteristics**

Parameter	Test Conditions	Minimum	Typical	Maximum	Units
Mode of Oscillation		Fundamental			
Frequency		23.33	26.5625	28.33	MHz
Equivalent Series Resistance (ESR)				50	Ω
Shunt Capacitance				7	pF

NOTE: Characterized using an 18pF parallel resonant crystal.

AC Electrical Characteristics

Table 5A. AC Characteristics, $V_{CC} = V_{CCA} = V_{CCO} = 3.3V \pm 5\%$, $V_{EE} = 0V$, $T_A = -40^\circ C$ to $85^\circ C$

Symbol	Parameter	Test Conditions	Minimum	Typical	Maximum	Units
f_{OUT}	Output Frequency Range	F_SEL[1:0] = 00	186.67		226.66	MHz
		F_SEL[1:0] = 01	140		170	MHz
		F_SEL[1:0] = 10	93.33		113.33	MHz
		F_SEL[1:0] = 11	46.67		56.66	MHz
$t_{sk(o)}$	Output Skew; NOTE 1, 2				50	ps
$f_{jit}(\emptyset)$	RMS Phase Jitter, (Random); NOTE 3	212.5MHz, (2.55MHz – 20MHz)		0.47		ps
		159.375MHz, (1.875MHz – 20MHz)		0.52		ps
		156.25MHz, (1.875MHz – 20MHz)		0.52		ps
		106.25MHz, (637kHz – 5MHz)		0.62		ps
		53.125MHz, (637kHz – 50MHz)		0.67		ps
t_R / t_F	Output Rise/Fall Time	20% to 80%	300		600	ps
odc	Output Duty Cycle	F_SEL[1:0] \neq 00	49		51	%
		F_SEL[1:0] = 00	42		58	%

NOTE: Electrical parameters are guaranteed over the specified ambient operating temperature range, which is established when the device is mounted in a test socket with maintained transverse airflow greater than 500 lpm. The device will meet specifications after thermal equilibrium has been reached under these conditions.

NOTE 1: Defined as skew between outputs at the same supply voltage and with equal load conditions. Measured at the differential cross points.

NOTE 2: This parameter is defined in accordance with JEDEC Standard 65.

NOTE 3: Please refer to the Phase Noise Plots.

Table 5B. AC Characteristics, $V_{CC} = V_{CCA} = V_{CCO} = 2.5V \pm 5\%$, $V_{EE} = 0V$, $T_A = -40^\circ C$ to $85^\circ C$

Symbol	Parameter	Test Conditions	Minimum	Typical	Maximum	Units
f_{OUT}	Output Frequency Range	F_SEL[1:0] = 00	186.67		226.66	MHz
		F_SEL[1:0] = 01	140		170	MHz
		F_SEL[1:0] = 10	93.33		113.33	MHz
		F_SEL[1:0] = 11	46.67		56.66	MHz
$t_{sk(o)}$	Output Skew; NOTE 1, 2				50	ps
$f_{jit}(\emptyset)$	RMS Phase Jitter, (Random)	212.5MHz, (2.55MHz – 20MHz)		0.49		ps
		159.375MHz, (1.875MHz – 20MHz)		0.52		ps
		156.25MHz, (1.875MHz – 20MHz)		0.52		ps
		106.25MHz, (637kHz – 5MHz)		0.65		ps
		53.125MHz, (637kHz – 50MHz)		0.71		ps
t_R / t_F	Output Rise/Fall Time	20% to 80%	300		600	ps
odc	Output Duty Cycle	F_SEL[1:0] \neq 00	48		52	%
		F_SEL[1:0] = 00	42		58	%

NOTE: Electrical parameters are guaranteed over the specified ambient operating temperature range, which is established when the device is mounted in a test socket with maintained transverse airflow greater than 500 lpm. The device will meet specifications after thermal equilibrium has been reached under these conditions.

NOTE 1: Defined as skew between outputs at the same supply voltage and with equal load conditions. Measured at the differential cross points.

NOTE 2: This parameter is defined in accordance with JEDEC Standard 65.

Typical Phase Noise at 53.125MHz at 3.3V

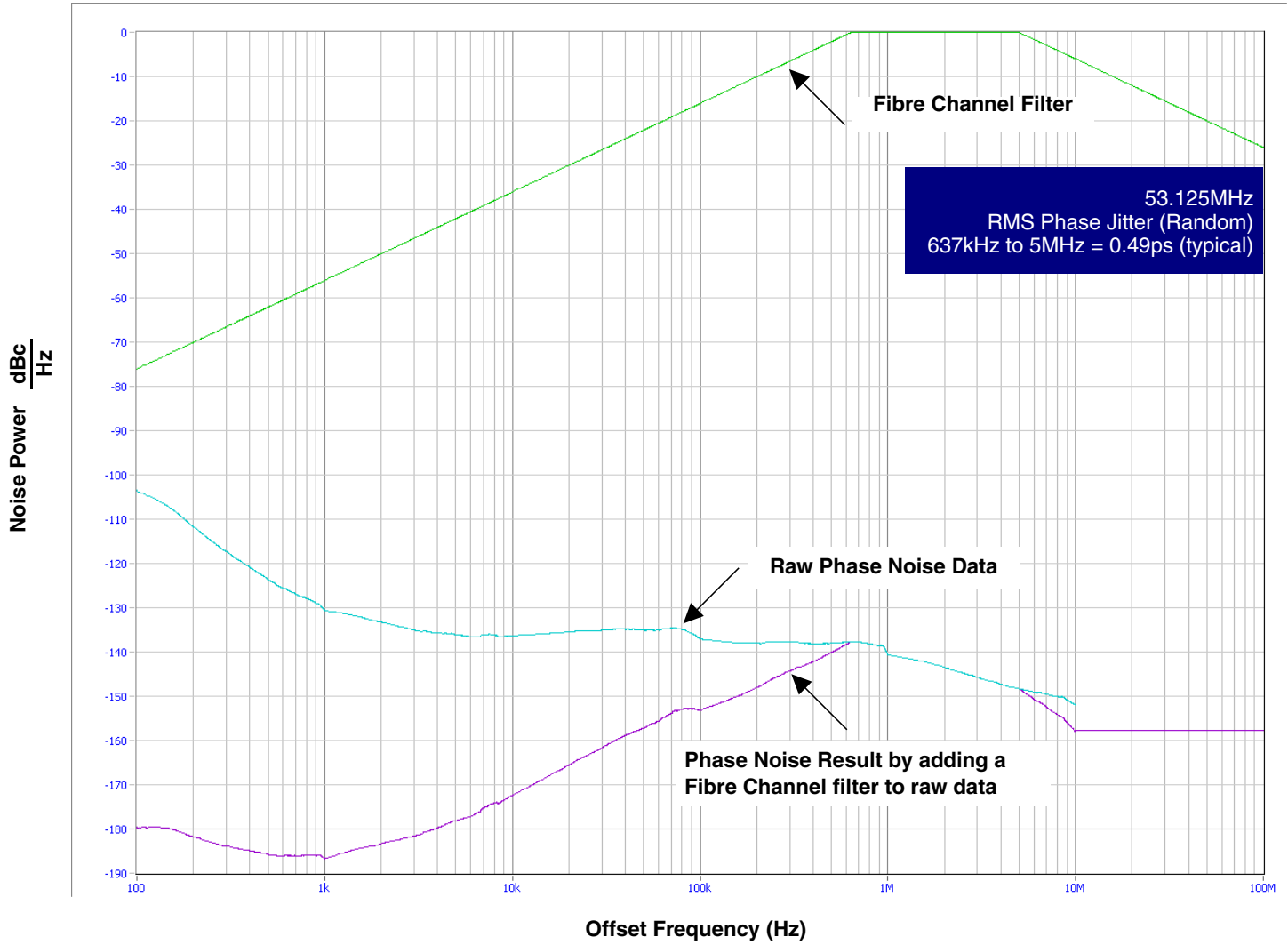

Typical Phase Noise at 212.5MHz at 3.3V

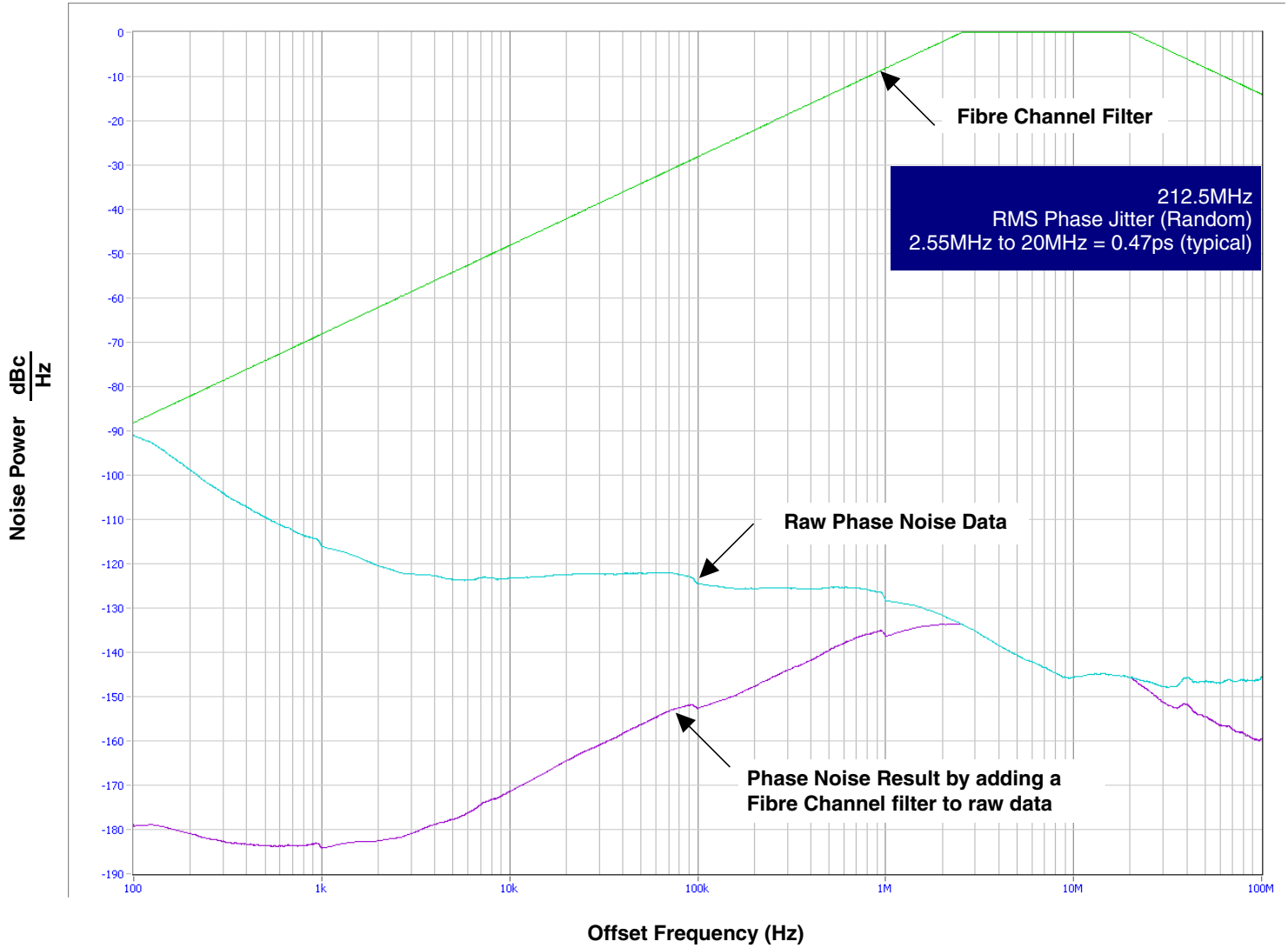

Parameter Measurement Information

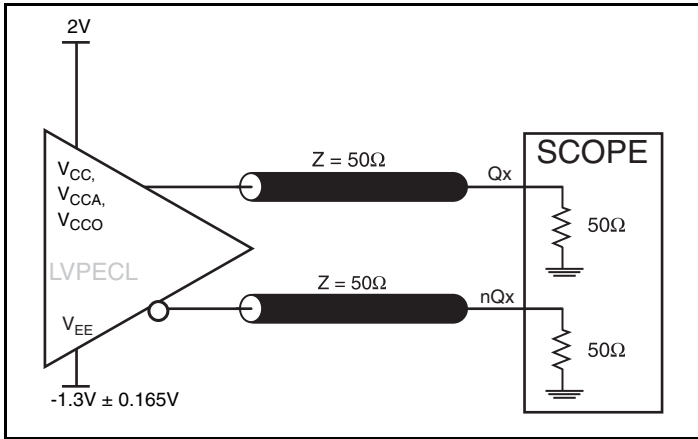

3.3V Core/ 3.3V Output Load AC Test Circuit

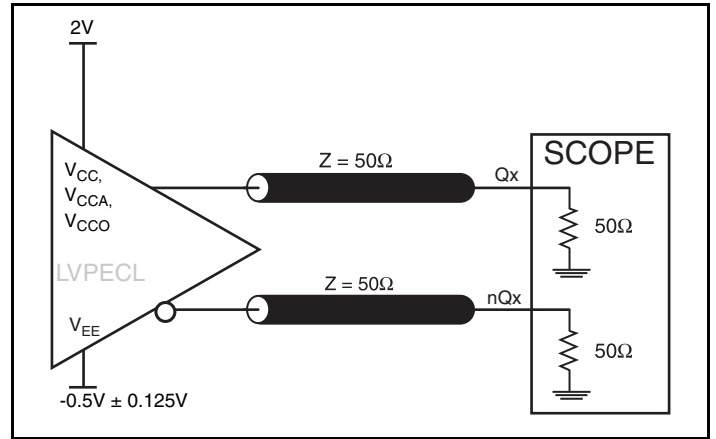

2.5V Core/ 2.5V Output Load AC Test Circuit

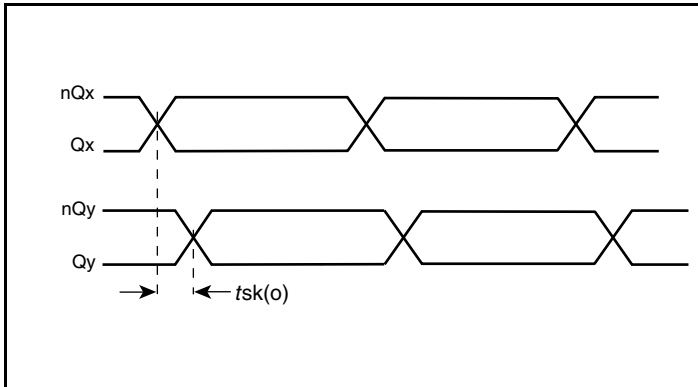

Output Skew

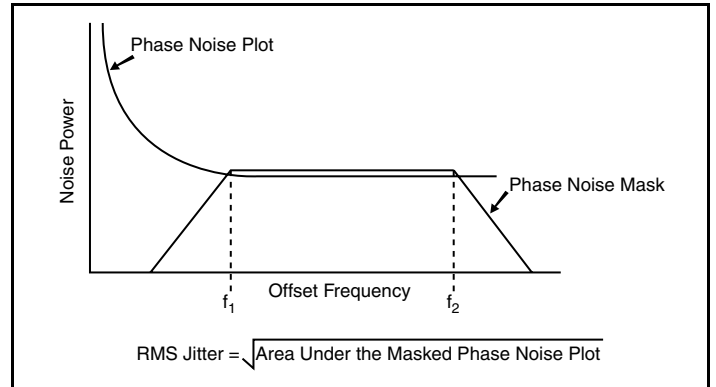

RMS Phase Jitter

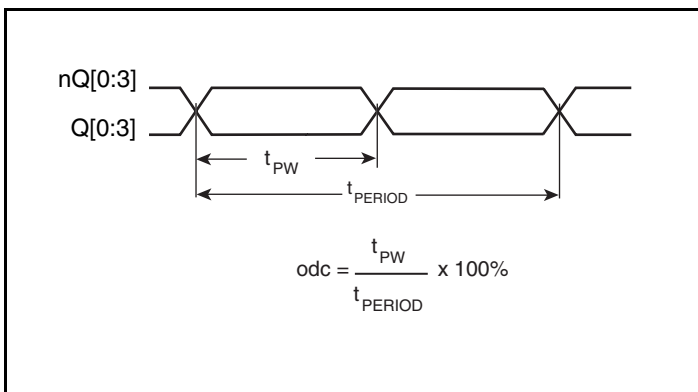

Output Duty Cycle/Pulse Width/Period

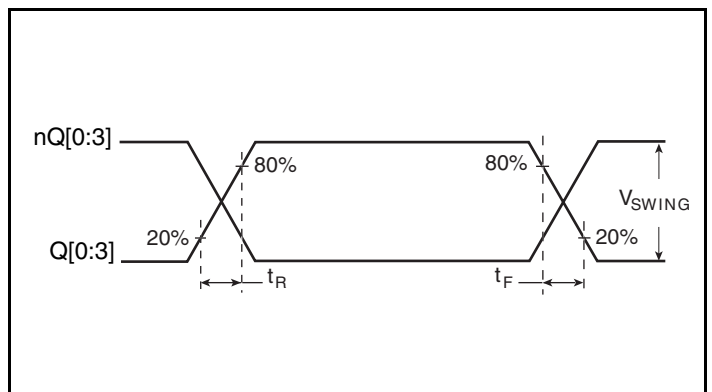

Output Rise/Fall Time

Application Information

Power Supply Filtering Technique

As in any high speed analog circuitry, the power supply pins are vulnerable to random noise. To achieve optimum jitter performance, power supply isolation is required. The ICS843004I provides separate power supplies to isolate any high switching noise from the outputs to the internal PLL. V_{CC} , V_{CCA} and V_{CCO} should be individually connected to the power supply plane through vias, and $0.01\mu\text{F}$ bypass capacitors should be used for each pin. *Figure 1* illustrates this for a generic V_{CC} pin and also shows that V_{CCA} requires that an additional 10Ω resistor along with a $10\mu\text{F}$ bypass capacitor be connected to the V_{CCA} pin.

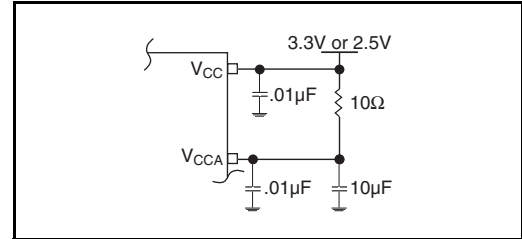

Figure 1. Power Supply Filtering

Recommendations for Unused Input and Output Pins

Inputs:

Crystal Inputs

For applications not requiring the use of the crystal oscillator input, both XTAL_IN and XTAL_OUT can be left floating. Though not required, but for additional protection, a $1\text{k}\Omega$ resistor can be tied from XTAL_IN to ground.

TEST_CLK Input

For applications not requiring the use of the clock, it can be left floating. Though not required, but for additional protection, a $1\text{k}\Omega$ resistor can be tied from the TEST_CLK to ground.

LVCMOS Control Pins

All control pins have internal pulldowns; additional resistance is not required but can be added for additional protection. A $1\text{k}\Omega$ resistor can be used.

Outputs:

LVPECL Outputs

All unused LVPECL outputs can be left floating. We recommend that there is no trace attached. Both sides of the differential output pair should either be left floating or terminated.

Crystal Input Interface

The ICS843004I has been characterized with 18pF parallel resonant crystals. The capacitor values shown in *Figure 2* below were determined using a 26.5625MHz, 18pF parallel resonant crystal and were chosen to minimize the ppm error.

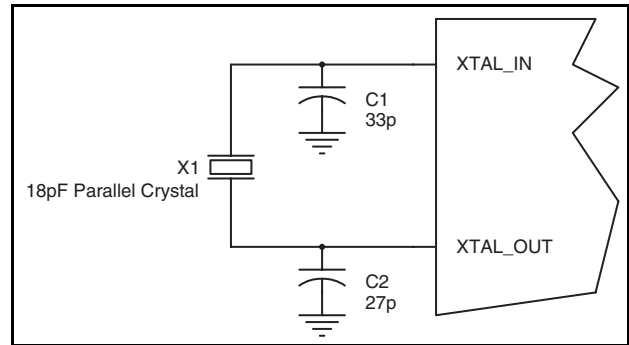

Figure 2. Crystal Input Interface

Overdriving the XTAL Interface

The XTAL_IN input can accept a single-ended LVCMOS signal through an AC coupling capacitor. A general interface diagram is shown in *Figure 3A*. The XTAL_OUT pin can be left floating. The maximum amplitude of the input signal should not exceed 2V and the input edge rate can be as slow as 10ns. This configuration requires that the output impedance of the driver (R_o) plus the series resistance (R_s) equals the transmission line impedance. In addition,

matched termination at the crystal input will attenuate the signal in half. This can be done in one of two ways. First, R_1 and R_2 in parallel should equal the transmission line impedance. For most 50 Ω applications, R_1 and R_2 can be 100 Ω . This can also be accomplished by removing R_1 and making R_2 50 Ω . By overdriving the crystal oscillator, the device will be functional, but note, the device performance is guaranteed by using a quartz crystal.

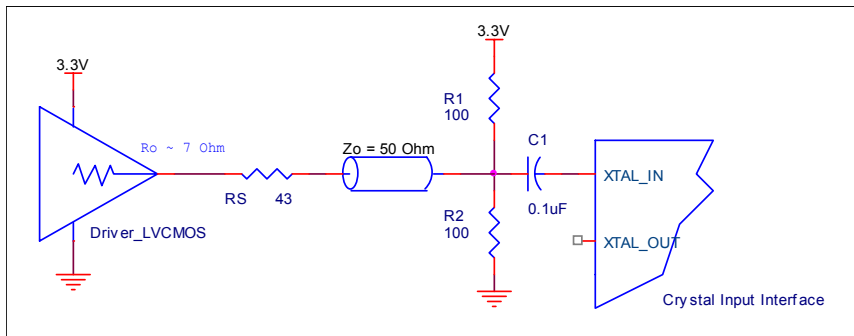

Figure 3A. General Diagram for LVCMOS Driver to XTAL Input Interface

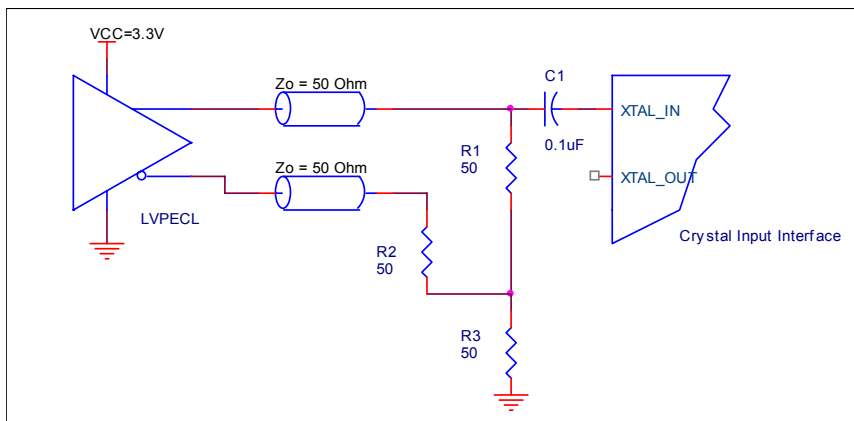

Figure 3B. General Diagram for LVPECL Driver to XTAL Input Interface

Termination for 3.3V LVPECL Outputs

The clock layout topology shown below is a typical termination for LVPECL outputs. The two different layouts mentioned are recommended only as guidelines.

The differential outputs are low impedance follower outputs that generate ECL/LVPECL compatible outputs. Therefore, terminating resistors (DC current path to ground) or current sources must be used for functionality. These outputs are designed to drive 50Ω

transmission lines. Matched impedance techniques should be used to maximize operating frequency and minimize signal distortion.

Figures 4A and 4B show two different layouts which are recommended only as guidelines. Other suitable clock layouts may exist and it would be recommended that the board designers simulate to guarantee compatibility across all printed circuit and clock component process variations.

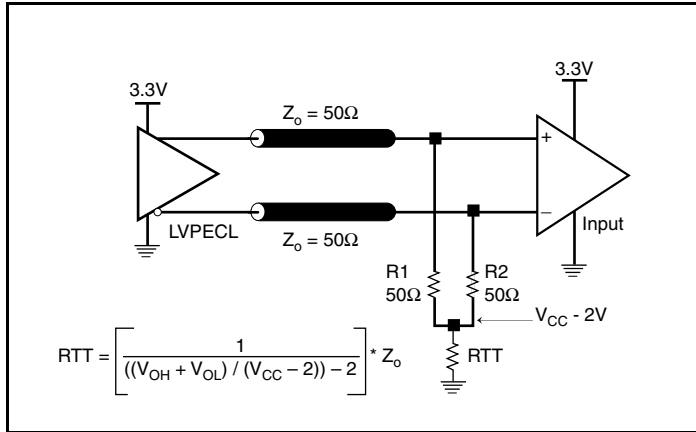

Figure 4A. 3.3V LVPECL Output Termination

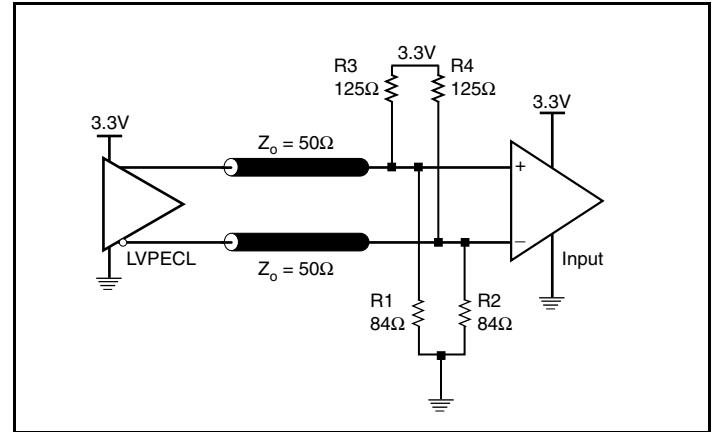

Figure 4B. 3.3V LVPECL Output Termination

Termination for 2.5V LVPECL Outputs

Figure 5A and Figure 5B show examples of termination for 2.5V LVPECL driver. These terminations are equivalent to terminating 50Ω to $V_{CC} - 2V$. For $V_{CC0} = 2.5V$, the $V_{CC0} - 2V$ is very close to ground

level. The R3 in Figure 5B can be eliminated and the termination is shown in Figure 5C.

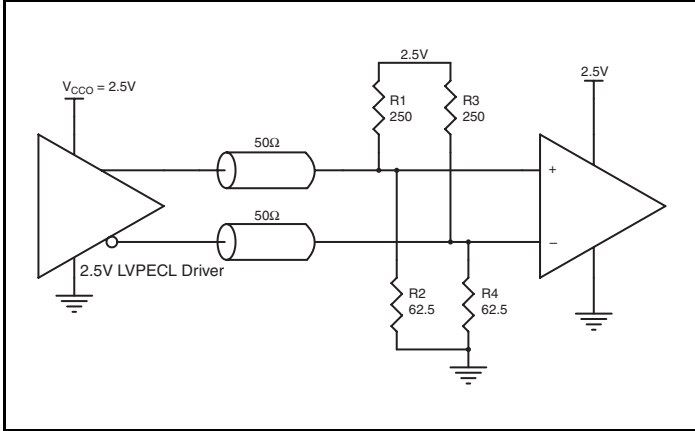

Figure 5A. 2.5V LVPECL Driver Termination Example

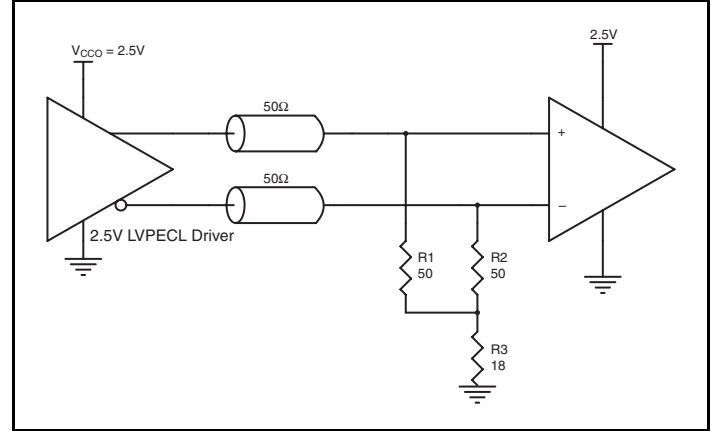

Figure 5B. 2.5V LVPECL Driver Termination Example

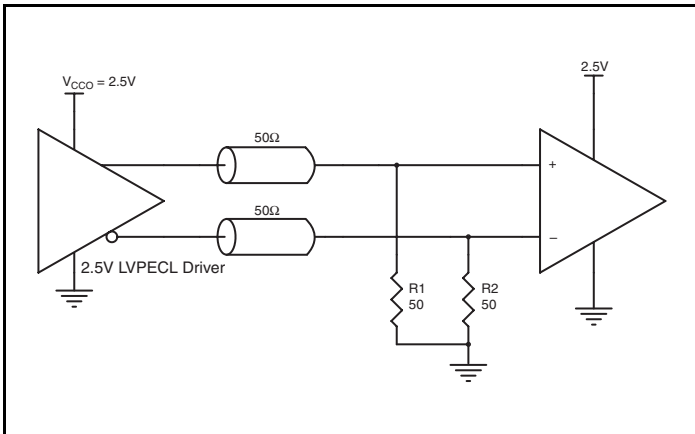

Figure 5C. 2.5V LVPECL Driver Termination Example

Layout Guideline

Figure 6 shows a schematic example of the ICS843004I. An example of LVEPCL termination is shown in this schematic. Additional LVPECL termination approaches are shown in the LVPECL Termination Application Note. In this example, an 18pF parallel

resonant 26.5625MHz crystal is used. The C1= 27pF and C2 = 33pF are recommended for frequency accuracy. For different board layout, the C1 and C2 may be slightly adjusted for optimizing frequency accuracy.

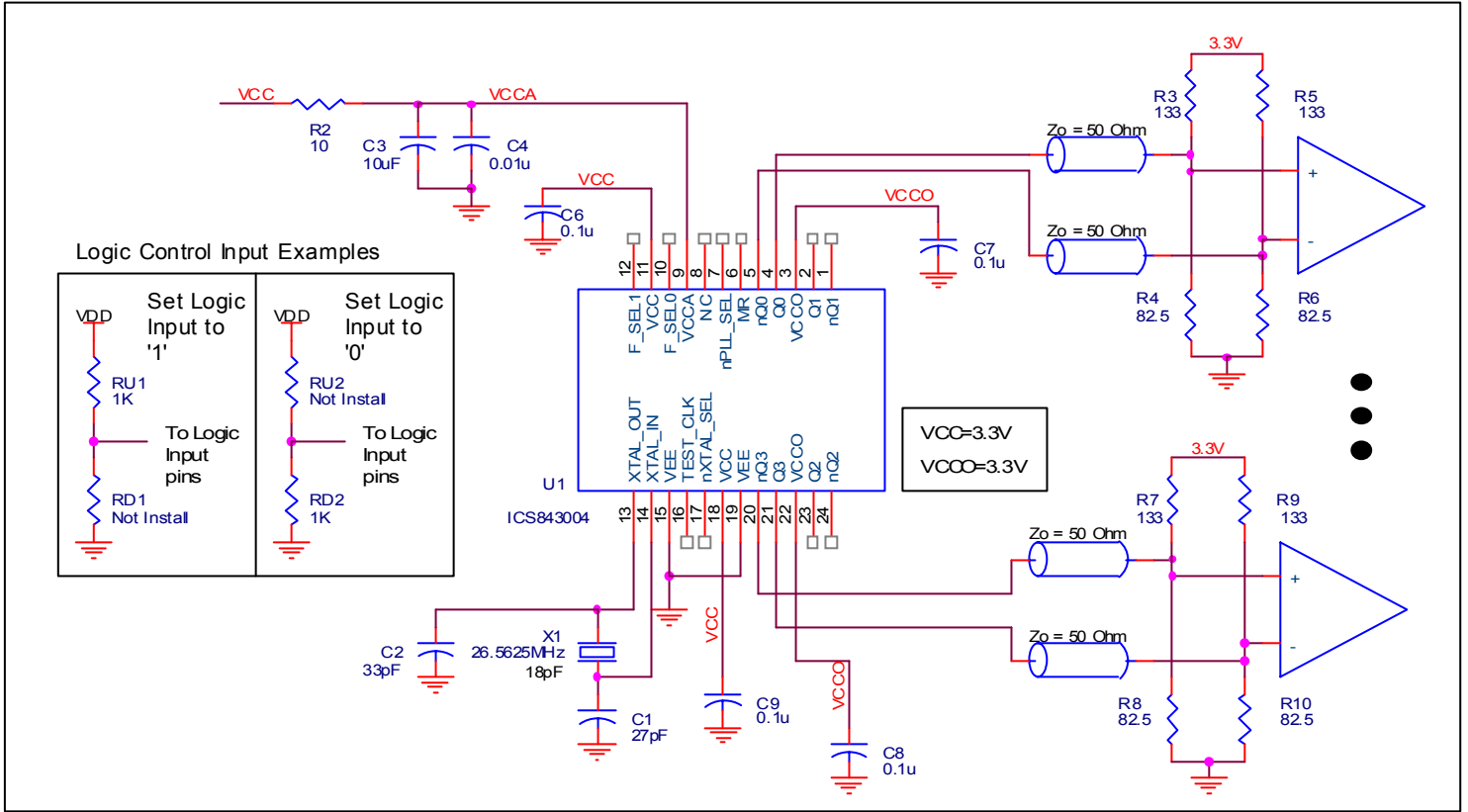

Figure 6. ICS843004I Schematic Example

Power Considerations

This section provides information on power dissipation and junction temperature for the ICS843004I. Equations and example calculations are also provided.

1. Power Dissipation.

The total power dissipation for the ICS843004I is the sum of the core power plus the power dissipated in the load(s). The following is the power dissipation for $V_{CC} = 3.3V + 5\% = 3.465V$, which gives worst case results.

NOTE: Please refer to Section 3 for details on calculating power dissipated in the load.

- Power (core)_{MAX} = $V_{CC_MAX} * I_{EE_MAX} = 3.465V * 130mA = 450.45mW$
- Power (outputs)_{MAX} = **30mW/Loaded Output pair**
If all outputs are loaded, the total power is $4 * 30mW = 120mW$

Total Power_{MAX} (3.465V, with all outputs switching) = $450.45mW + 120mW = 570.45mW$

2. Junction Temperature.

Junction temperature, T_j , is the temperature at the junction of the bond wire and bond pad directly affects the reliability of the device. The maximum recommended junction temperature is 125°C. Limiting the internal transistor junction temperature, T_j , to 125°C ensures that the bond wire and bond pad temperature remains below 125°C.

The equation for T_j is as follows: $T_j = \theta_{JA} * Pd_total + T_A$

T_j = Junction Temperature

θ_{JA} = Junction-to-Ambient Thermal Resistance

Pd_total = Total Device Power Dissipation (example calculation is in section 1 above)

T_A = Ambient Temperature

In order to calculate junction temperature, the appropriate junction-to-ambient thermal resistance θ_{JA} must be used. Assuming a moderate air flow of 1 meter per second and a multi-layer board, the appropriate value is 65°C/W per Table 6 below.

Therefore, T_j for an ambient temperature of 85°C with all outputs switching is:

$$85^\circ\text{C} + 0.571\text{W} * 65^\circ\text{C/W} = 122.1^\circ\text{C}. \text{ This is below the limit of } 125^\circ\text{C}.$$

This calculation is only an example. T_j will obviously vary depending on the number of loaded outputs, supply voltage, air flow and the type of board (multi-layer).

Table 6. Thermal Resistance θ_{JA} for 24 Lead TSSOP, Forced Convection

θ_{JA} vs. Air Flow			
Meters per Second	0	1	2.5
Multi-Layer PCB, JEDEC Standard Test Boards	70°C/W	65°C/W	62°C/W

3. Calculations and Equations.

The purpose of this section is to calculate the power dissipation for the LVPECL output pairs.

LVPECL output driver circuit and termination are shown in *Figure 7*.

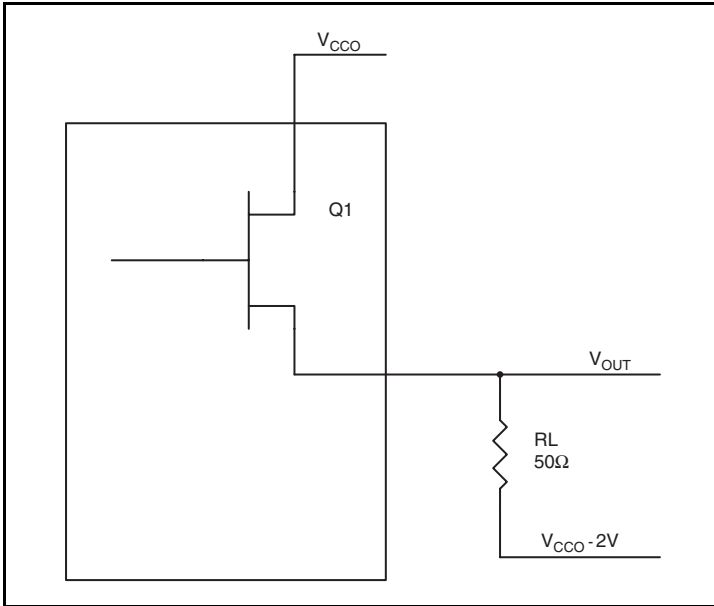

Figure 7. LVPECL Driver Circuit and Termination

To calculate worst case power dissipation into the load, use the following equations which assume a 50Ω load, and a termination voltage of $V_{CCO} - 2V$.

- For logic high, $V_{OUT} = V_{OH_MAX} = V_{CCO_MAX} - 0.9V$
($V_{CCO_MAX} - V_{OH_MAX}$) = **0.9V**
- For logic low, $V_{OUT} = V_{OL_MAX} = V_{CCO_MAX} - 1.7V$
($V_{CCO_MAX} - V_{OL_MAX}$) = **1.7V**

Pd_H is power dissipation when the output drives high.

Pd_L is the power dissipation when the output drives low.

$$Pd_H = [(V_{OH_MAX} - (V_{CCO_MAX} - 2V))/R_L] * (V_{CCO_MAX} - V_{OH_MAX}) = [(2V - (V_{CCO_MAX} - V_{OH_MAX}))/R_L] * (V_{CCO_MAX} - V_{OH_MAX}) = [(2V - 0.9V)/50\Omega] * 0.9V = \mathbf{19.8mW}$$

$$Pd_L = [(V_{OL_MAX} - (V_{CCO_MAX} - 2V))/R_L] * (V_{CCO_MAX} - V_{OL_MAX}) = [(2V - (V_{CCO_MAX} - V_{OL_MAX}))/R_L] * (V_{CCO_MAX} - V_{OL_MAX}) = [(2V - 1.7V)/50\Omega] * 1.7V = \mathbf{10.2mW}$$

$$\text{Total Power Dissipation per output pair} = Pd_H + Pd_L = \mathbf{30mW}$$

Reliability Information

Table 7. θ_{JA} vs. Air Flow Table for a 24 Lead TSSOP

θ_{JA} vs. Air Flow			
Meters per Second	0	1	2.5
Multi-Layer PCB, JEDEC Standard Test Boards	70°C/W	65	62

Transistor Count

The transistor count for ICS843004I is: 2578

Package Outline and Package Dimensions

Package Outline - G Suffix for 24 Lead TSSOP

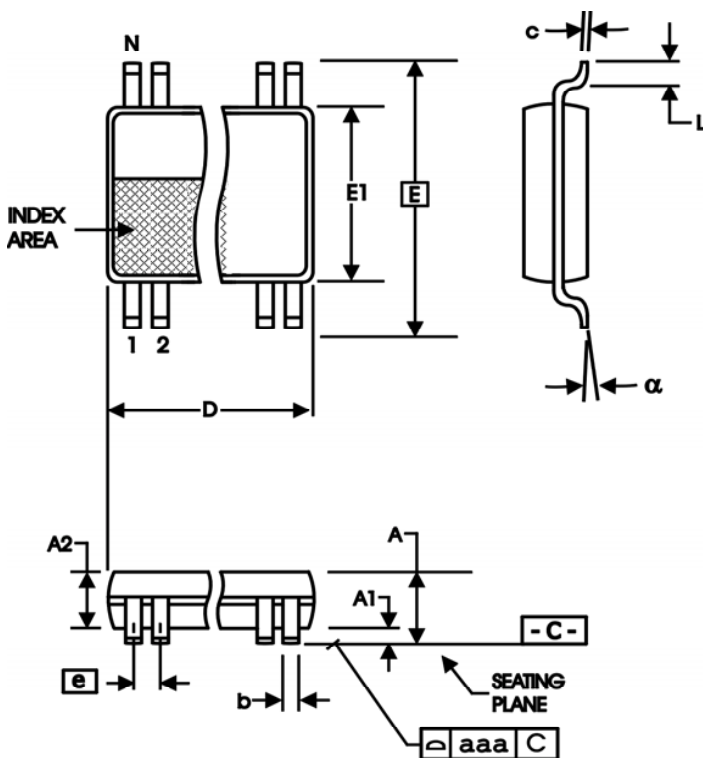

Table 8. Package Dimensions

All Dimensions in Millimeters		
Symbol	Minimum	Maximum
N	24	
A		1.20
A1	0.5	0.15
A2	0.80	1.05
b	0.19	0.30
c	0.09	0.20
D	7.70	7.90
E	6.40 Basic	
E1	4.30	4.50
e	0.65 Basic	
L	0.45	0.75
α	0°	8°
aaa		0.10

Reference Document: JEDEC Publication 95, MO-153

Ordering Information

Table 9. Ordering Information

Part/Order Number	Marking	Package	Shipping Packaging	Temperature
843004AGI	ICS843004AGI	24 Lead TSSOP	Tube	-40°C to 85°C
843004AGIT	ICS843004AGI	24 Lead TSSOP	2500 Tape & Reel	-40°C to 85°C
843004AGILF	ICS843004AGIL	"Lead-Free" 24 Lead TSSOP	Tube	-40°C to 85°C
843004AGILFT	ICS843004AGIL	"Lead-Free" 24 Lead TSSOP	2500 Tape & Reel	-40°C to 85°C

NOTE: Parts that are ordered with an "LF" suffix to the part number are the Pb-Free configuration and are RoHS compliant.

While the information presented herein has been checked for both accuracy and reliability, Integrated Device Technology (IDT) assumes no responsibility for either its use or for the infringement of any patents or other rights of third parties, which would result from its use. No other circuits, patents, or licenses are implied. This product is intended for use in normal commercial and industrial applications. Any other applications, such as those requiring high reliability or other extraordinary environmental requirements are not recommended without additional processing by IDT. IDT reserves the right to change any circuitry or specifications without notice. IDT does not authorize or warrant any IDT product for use in life support devices or critical medical instruments.

Revision History Sheet

Rev	Table	Page	Description of Change	Date
A	T5A, T5B	5	AC Characteristics Table - added Thermal Note.	2/19/10
		9	Added <i>Recommendations for Unused Input and Output Pins</i> section.	
		9	Reworded text in <i>Power Supply Filtering Techniques</i> .	
		10	Added <i>Overdriving the XTAL Interface</i> section.	
	11	Updated Figures 4A and 4B.		
	T9	17	Ordering Information Table - added lead-free marking. Deleted "ICS" prefix from part/order number. Datasheet conversion.	



www.IDT.com

6024 Silver Creek Valley Road
San Jose, California 95138

Sales
800-345-7015 (inside USA)
+408-284-8200 (outside USA)
Fax: 408-284-2775
www.IDT.com/go/contactIDT

Technical Support
netcom@idt.com
+480-763-2056

DISCLAIMER Integrated Device Technology, Inc. (IDT) and its subsidiaries reserve the right to modify the products and/or specifications described herein at any time and at IDT's sole discretion. All information in this document, including descriptions of product features and performance, is subject to change without notice. Performance specifications and the operating parameters of the described products are determined in the independent state and are not guaranteed to perform the same way when installed in customer products. The information contained herein is provided without representation or warranty of any kind, whether express or implied, including, but not limited to, the suitability of IDT's products for any particular purpose, an implied warranty of merchantability, or non-infringement of the intellectual property rights of others. This document is presented only as a guide and does not convey any license under intellectual property rights of IDT or any third parties.

IDT's products are not intended for use in life support systems or similar devices where the failure or malfunction of an IDT product can be reasonably expected to significantly affect the health or safety of users. Anyone using an IDT product in such a manner does so at their own risk, absent an express, written agreement by IDT.

Integrated Device Technology, IDT and the IDT logo are registered trademarks of IDT. Other trademarks and service marks used herein, including protected names, logos and designs, are the property of IDT or their respective third party owners.

Copyright 2010. All rights reserved.