



FEMTOCLOCKS™ CRYSTAL-TO-3.3V LVPECL CLOCK GENERATOR

ICS843001

GENERAL DESCRIPTION



The ICS843001 is a Fibre Channel Clock Generator and a member of the HiPerClocks™ family of high performance devices from IDT. The ICS843001 uses either a 26.5625MHz or a 23.4375 crystal to synthesize 106.25MHz, 187.5MHz or 212.5MHz, using the **FREQ_SEL** pin. The ICS843001 has excellent <1ps phase jitter performance, over the 637kHz – 10MHz integration range. The ICS843001 is packaged in a small 8-pin TSSOP, making it ideal for use in systems with limited board space.

FEATURES

- One differential 3.3V LVPECL output
- Crystal oscillator interface designed for 23.4375MHz or 26.5625MHz, 18pF parallel resonant crystal
- Selectable 106.25MHz, 187.5MHz or 212.5MHz output frequency
- VCO range: 560MHz - 680MHz
- RMS phase jitter @ 106.255MHz, using a 26.5625MHz crystal (637kHz - 10MHz): 0.74ps (typical)
- RMS phase noise at 106.25MHz
Phase noise:

Offset	Noise Power
100Hz	-95.2 dBc/Hz
1KHz	-118.7 dBc/Hz
10KHz	-129.1 dBc/Hz
100KHz	-129.6 dBc/Hz
- 3.3V operating supply
- -30°C to 85°C ambient operating temperature
- Available in both standard (RoHS 5) and lead-free (RoHS 6) packages

FUNCTION TABLE

Inputs		Output Frequencies
Crystal Frequency	FREQ_SEL	
26.5625MHz	0	106.25MHz (Default)
26.5625MHz	1	212.5MHz
23.4375MHz	1	187.5MHz

BLOCK DIAGRAM

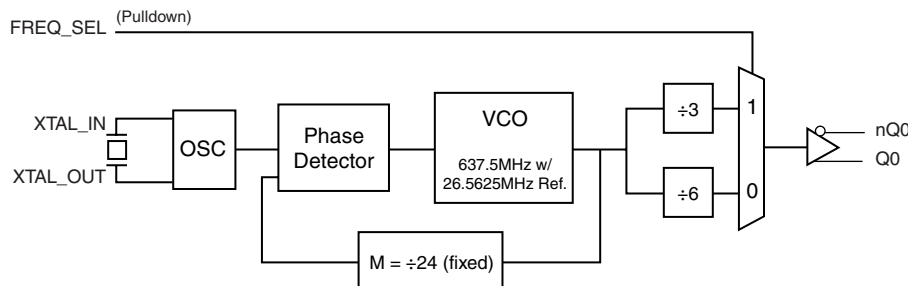

PIN ASSIGNMENT

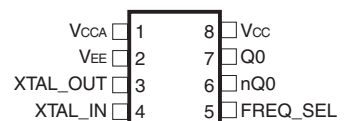

ICS843001

8-Lead TSSOP

4.40mm x 3.0mm x 0.925mm package body
G Package
 Top View

TABLE 1. PIN DESCRIPTIONS

Number	Name	Type		Description
1	V _{CCA}	Power		Analog supply pin.
2	V _{EE}	Power		Negative supply pin.
3, 4	XTAL_OUT, XTAL_IN	Input		Crystal oscillator interface. XTAL_IN is the input, XTAL_OUT is the output.
5	FREQ_SEL	Input	Pulldown	Frequency select pin. LVCMOS/LVTTL interface levels.
6, 7	nQ0, Q0	Output		Differential clock outputs. LVPECL interface levels.
8	V _{CC}	Power		Core supply pin.

NOTE: *Pulldown* refers to internal input resistors. See Table 2, Pin Characteristics, for typical values.

TABLE 2. PIN CHARACTERISTICS

Symbol	Parameter	Test Conditions	Minimum	Typical	Maximum	Units
C _{IN}	Input Capacitance			4		pF
R _{PULLDOWN}	Input Pulldown Resistor			51		kΩ

ABSOLUTE MAXIMUM RATINGS

Supply Voltage, V_{CC}	4.6V
Inputs, V_I	-0.5V to $V_{CC} + 0.5V$
Outputs, I_O	
Continuous Current	50mA
Surge Current	100mA
Package Thermal Impedance, θ_{JA}	101.7°C/W (0 mps)
Storage Temperature, T_{STG}	-65°C to 150°C

NOTE: Stresses beyond those listed under Absolute Maximum Ratings may cause permanent damage to the device. These ratings are stress specifications only. Functional operation of product at these conditions or any conditions beyond those listed in the *DC Characteristics* or *AC Characteristics* is not implied. Exposure to absolute maximum rating conditions for extended periods may affect product reliability.

TABLE 3A. POWER SUPPLY DC CHARACTERISTICS, $V_{CC} = 3.3V \pm 5\%$, $T_A = -30^\circ C$ TO $85^\circ C$

Symbol	Parameter	Test Conditions	Minimum	Typical	Maximum	Units
V_{CC}	Core Supply Voltage		3.135	3.3	3.465	V
V_{CCA}	Analog Supply Voltage		3.135	3.3	3.465	V
I_{CCA}	Analog Supply Current	included in I_{EE}			12	mA
I_{EE}	Power Supply Current				93	mA

TABLE 3B. LVCMOS/LVTTL DC CHARACTERISTICS, $V_{CC} = 3.3V \pm 5\%$, $T_A = -30^\circ C$ TO $85^\circ C$

Symbol	Parameter	Test Conditions	Minimum	Typical	Maximum	Units
V_{IH}	Input High Voltage		2		$V_{CC} + 0.3$	V
V_{IL}	Input Low Voltage		-0.3		0.8	V
I_{IH}	Input High Current	FREQ_SEL $V_{CC} = V_{IN} = 3.465V$			150	μA
I_{IL}	Input Low Current	FREQ_SEL $V_{CC} = 3.465V, V_{IN} = 0V$	-5			μA

TABLE 3C. LVPECL DC CHARACTERISTICS, $V_{CC} = 3.3V \pm 5\%$, $T_A = -30^\circ C$ TO $85^\circ C$

Symbol	Parameter	Test Conditions	Minimum	Typical	Maximum	Units
V_{OH}	Output High Voltage; NOTE 1		$V_{CC} - 1.4$		$V_{CC} - 0.9$	V
V_{OL}	Output Low Voltage; NOTE 1		$V_{CC} - 2.0$		$V_{CC} - 1.7$	V
V_{SWING}	Peak-to-Peak Output Voltage Swing		0.6		1.0	V

NOTE 1: Outputs terminated with 50Ω to $V_{CC} - 2V$.

TABLE 4. CRYSTAL CHARACTERISTICS

Parameter	Test Conditions	Minimum	Typical	Maximum	Units
Mode of Oscillation		Fundamental			
Frequency		23.4375		26.5625	MHz
Equivalent Series Resistance (ESR)				50	Ω
Shunt Capacitance				7	pF

TABLE 5. AC CHARACTERISTICS, $V_{CC} = 3.3V \pm 5\%$, $T_A = -30^\circ C$ TO $85^\circ C$

Symbol	Parameter	Test Conditions	Minimum	Typical	Maximum	Units
f_{OUT}	Output Frequency	FREQ_SEL = 1	186.67		226.66	MHz
		FREQ_SEL = 0	93.33		113.33	MHz
$f_{jit}(\emptyset)$	RMS Phase Jitter, (Random); NOTE 1	212.5MHz, (637KHz to 10MHz)		0.67		ps
		187.5MHz, (1.875MHz to 20MHz)		0.52		ps
		106.25MHz, (637KHz to 10MHz)		0.74		ps
t_R / t_F	Output Rise/Fall Time	20% to 80%	300		600	ps
odc	Output Duty Cycle	FSEL = 0	48		52	%
		FSEL = 1	45		55	%

NOTE 1: Please refer to Phase Noise Plot.

TYPICAL PHASE NOISE AT 106.25MHz

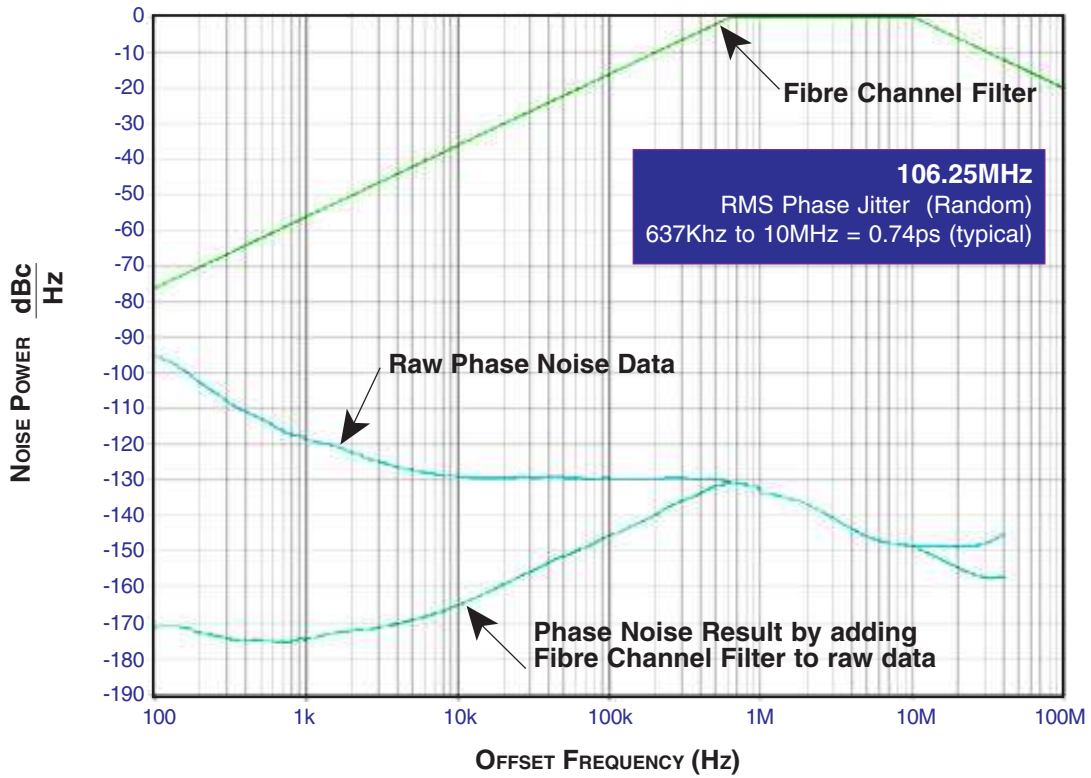

TYPICAL PHASE NOISE AT 212.5MHz

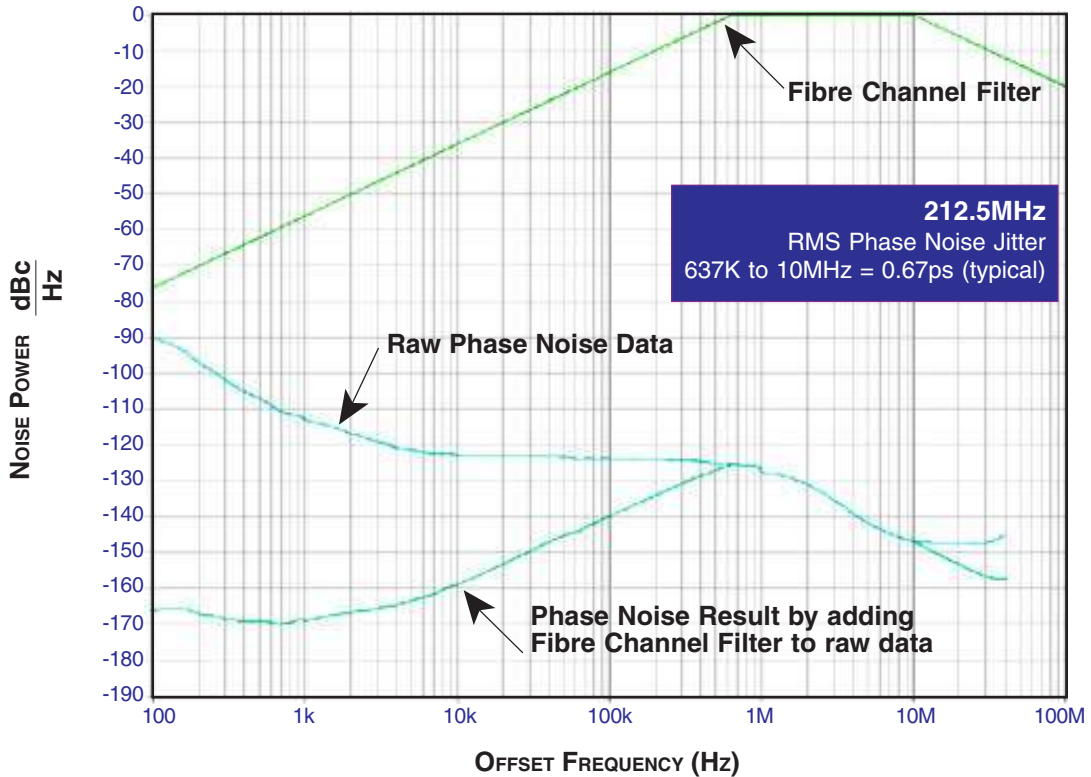

TYPICAL PHASE NOISE AT 187.5MHz

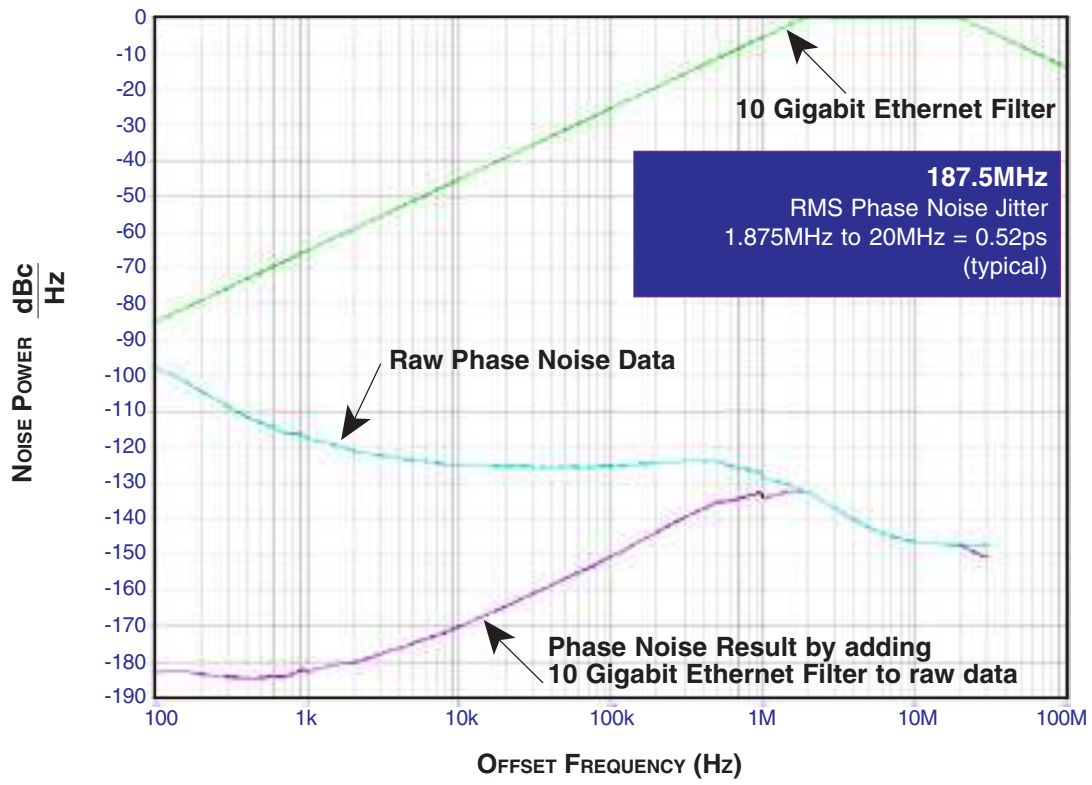

PARAMETER MEASUREMENT INFORMATION

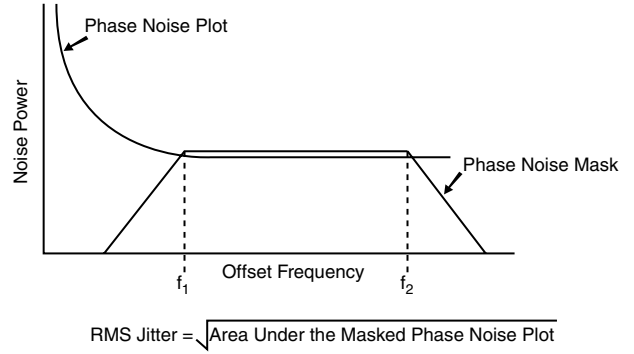
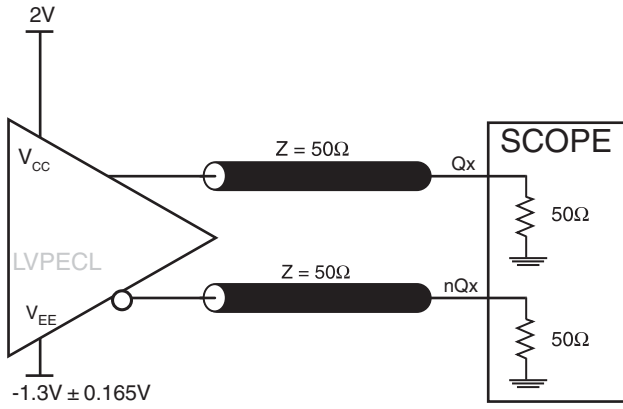

3.3V OUTPUT LOAD AC TEST CIRCUIT

RMS PHASE JITTER

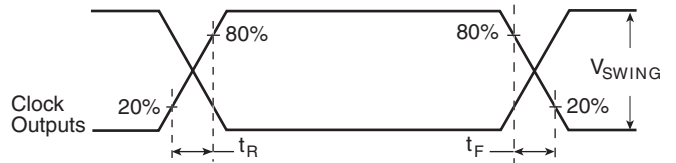
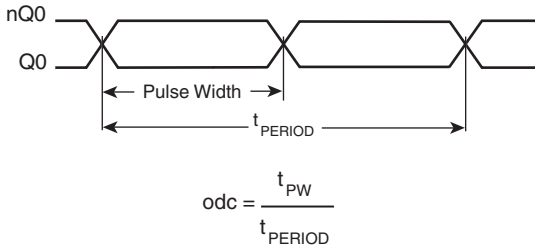

OUTPUT DUTY CYCLE/PULSE WIDTH/PERIOD

OUTPUT RISE/FALL TIME

APPLICATION INFORMATION

POWER SUPPLY FILTERING TECHNIQUES

As in any high speed analog circuitry, the power supply pins are vulnerable to random noise. The ICS843001 provides separate power supplies to isolate any high switching noise from the outputs to the internal PLL. V_{CC} and V_{CCA} should be individually connected to the power supply plane through vias, and bypass capacitors should be used for each pin. To achieve optimum jitter performance, power supply isolation is required. *Figure 1* illustrates how a 10Ω resistor along with a $10\mu\text{F}$ and a $.01\mu\text{F}$ bypass capacitor should be connected to each V_{CCA} pin.

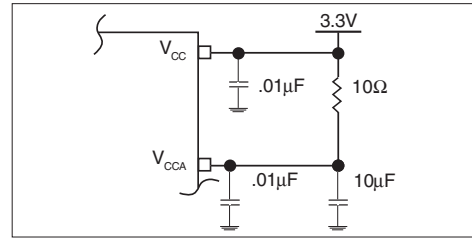

FIGURE 1. POWER SUPPLY FILTERING

CRYSTAL INPUT INTERFACE

The ICS843001 has been characterized with 18pF parallel resonant crystals. The capacitor values, C1 and C2, shown in *Figure 2* below were determined using a 26.5625MHz, 18pF

parallel resonant crystal and were chosen to minimize the ppm error. The optimum C1 and C2 values can be slightly adjusted for different board layouts.

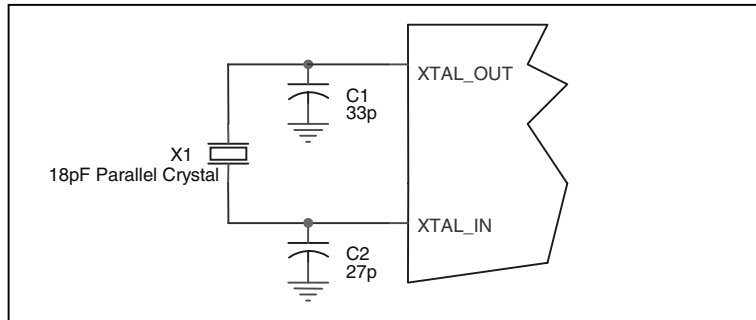

FIGURE 2. CRYSTAL INPUT INTERFACE

LAYOUT GUIDELINE

Figure 3A shows a schematic example of the ICS843001. An example of LVPECL termination is shown in this schematic. Additional LVPECL termination approaches are shown in the LVPECL Termination Application Note. In this example, an 18pF

parallel resonant crystal is used. The C1 = 27pF and C2 = 33pF are recommended for frequency accuracy. The C1 and C2 values may be slightly adjusted for optimizing frequency accuracy.

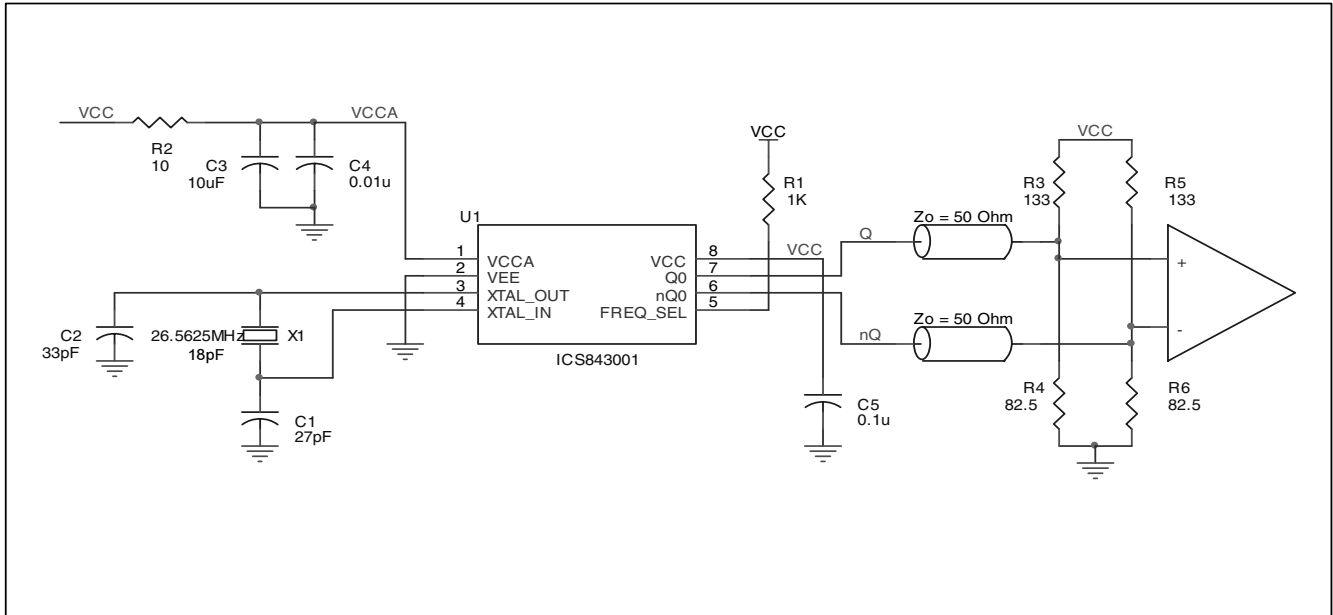

FIGURE 3A. ICS843001 SCHEMATIC EXAMPLE

PC BOARD LAYOUT EXAMPLE

Figure 3B shows an example of ICS843001 P.C. board layout. The crystal X1 footprint shown in this example allows installation of either surface mount HC49S or through-hole HC49 package. The footprints of other components in this example are listed in

the Table 6. There should be at least one decoupling capacitor per power pin. The decoupling capacitors should be located as close as possible to the power pins. The layout assumes that the board has clean analog power ground plane.

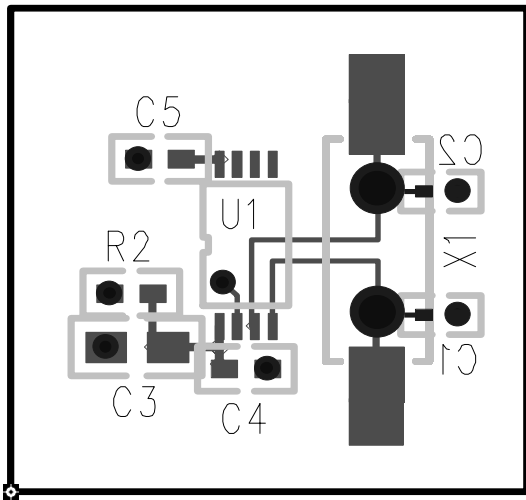

FIGURE 3B. ICS843001 PC BOARD LAYOUT EXAMPLE

TABLE 6. FOOTPRINT TABLE

Reference	Size
C1, C2	0402
C3	0805
C4, C5	0603
R2	0603

NOTE: Table 6, lists component sizes shown in this layout example.

POWER CONSIDERATIONS

This section provides information on power dissipation and junction temperature for the ICS843001. Equations and example calculations are also provided.

1. Power Dissipation.

The total power dissipation for the ICS843001 is the sum of the core power plus the power dissipated in the load(s). The following is the power dissipation for $V_{CC} = 3.3V + 5\% = 3.465V$, which gives worst case results.

NOTE: Please refer to Section 3 for details on calculating power dissipated in the load.

- Power (core)_{MAX} = $V_{CC,MAX} * I_{EE,MAX} = 3.465V * 93mA = 322.2mW$
- Power (outputs)_{MAX} = **30mW/Loaded Output pair**

$$\text{Total Power}_{MAX} (3.465V, \text{ with all outputs switching}) = 322.2mW + 30mW = 352.2mW$$

2. Junction Temperature.

Junction temperature, T_j , is the temperature at the junction of the bond wire and bond pad and directly affects the reliability of the device. The maximum recommended junction temperature for HiPerClockS™ devices is 125°C.

The equation for T_j is as follows: $T_j = \theta_{JA} * Pd_{total} + T_A$

T_j = Junction Temperature

θ_{JA} = Junction-to-Ambient Thermal Resistance

Pd_{total} = Total Device Power Dissipation (example calculation is in section 1 above)

T_A = Ambient Temperature

In order to calculate junction temperature, the appropriate junction-to-ambient thermal resistance θ_{JA} must be used. Assuming a moderate air flow of 1 meter per second and a multi-layer board, the appropriate value is 90.5°C/W per Table 7 below.

Therefore, T_j for an ambient temperature of 85°C with all outputs switching is:

$$85^\circ C + 0.352W * 90.5^\circ C/W = 116.9^\circ C. \text{ This is below the limit of } 125^\circ C.$$

This calculation is only an example. T_j will obviously vary depending on the number of loaded outputs, supply voltage, air flow, and the type of board (single layer or multi-layer).

TABLE 7. THERMAL RESISTANCE θ_{JA} FOR 8-PIN TSSOP, FORCED CONVECTION

θ_{JA} by Velocity (Meters per Second)			
	0	1	2.5
Multi-Layer PCB, JEDEC Standard Test Boards	101.7°C/W	90.5°C/W	89.8°C/W

3. Calculations and Equations.

The purpose of this section is to derive the power dissipated into the load. LVPECL output driver circuit and termination are shown in Figure 4.

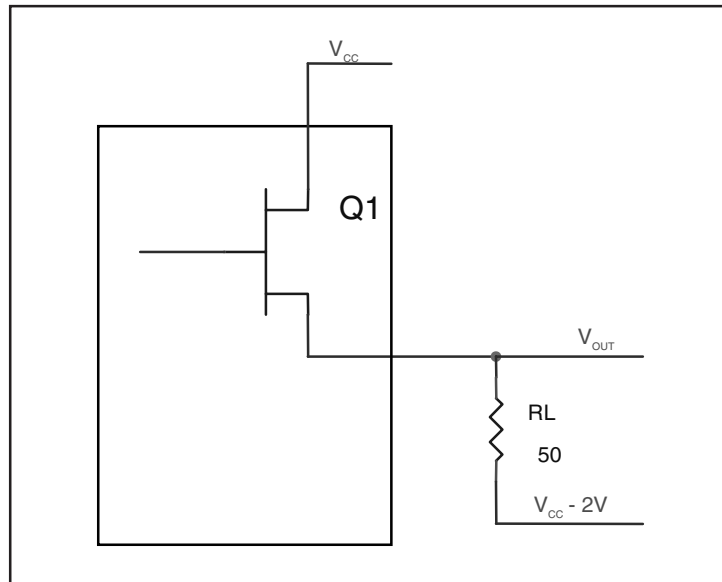

FIGURE 4. LVPECL DRIVER CIRCUIT AND TERMINATION

To calculate worst case power dissipation into the load, use the following equations which assume a 50Ω load, and a termination voltage of $V_{CC} - 2V$.

- For logic high, $V_{OUT} = V_{OH_MAX} = V_{CC_MAX} - 0.9V$

$$(V_{CC_MAX} - V_{OH_MAX}) = 0.9V$$

- For logic low, $V_{OUT} = V_{OL_MAX} = V_{CC_MAX} - 1.7V$

$$(V_{CC_MAX} - V_{OL_MAX}) = 1.7V$$

Pd_H is power dissipation when the output drives high.

Pd_L is the power dissipation when the output drives low.

$$Pd_H = [(V_{OH_MAX} - (V_{CC_MAX} - 2V))/R_L] * (V_{CC_MAX} - V_{OH_MAX}) = [(2V - (V_{CC_MAX} - V_{OH_MAX}))/R_L] * (V_{CC_MAX} - V_{OH_MAX}) = [(2V - 0.9V)/50\Omega] * 0.9V = 19.8mW$$

$$Pd_L = [(V_{OL_MAX} - (V_{CC_MAX} - 2V))/R_L] * (V_{CC_MAX} - V_{OL_MAX}) = [(2V - (V_{CC_MAX} - V_{OL_MAX}))/R_L] * (V_{CC_MAX} - V_{OL_MAX}) = [(2V - 1.7V)/50\Omega] * 1.7V = 10.2mW$$

Total Power Dissipation per output pair = Pd_H + Pd_L = 30mW

RELIABILITY INFORMATION

TABLE 8. θ_{JA} VS. AIR FLOW TABLE FOR 8 LEAD TSSOP

θ_{JA} by Velocity (Meters per Second)			
	0	1	2.5
Multi-Layer PCB, JEDEC Standard Test Boards	101.7°C/W	90.5°C/W	89.8°C/W

TRANSISTOR COUNT

The transistor count for ICS843001 is: 1702

PACKAGE OUTLINE - G SUFFIX 8 LEAD TSSOP

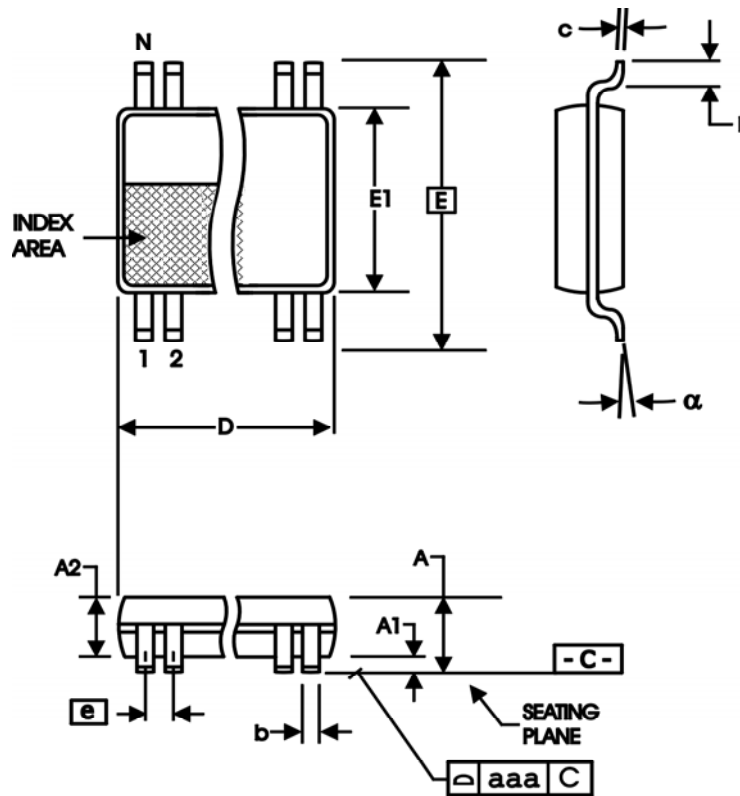

TABLE 9. PACKAGE DIMENSIONS

SYMBOL	Millimeters	
	Minimum	Maximum
N	8	
A	--	1.20
A1	0.05	0.15
A2	0.80	1.05
b	0.19	0.30
c	0.09	0.20
D	2.90	3.10
E	6.40 BASIC	
E1	4.30	4.50
e	0.65 BASIC	
L	0.45	0.75
α	0°	8°
aaa	--	0.10

Reference Document: JEDEC Publication 95, MO-153

TABLE 10. ORDERING INFORMATION

Part/Order Number	Marking	Package	Shipping Packaging	Temperature
843001AG	3001A	8 Lead TSSOP	Tube	-30°C to 85°C
843001AGT	3001A	8 Lead TSSOP	2500 Tape & Reel	-30°C to 85°C
843001AGLF	001AL	8 Lead "Lead-Free" TSSOP	Tube	-30°C to 85°C
843001AGLFT	001AL	8 Lead "Lead-Free" TSSOP	2500 Tape & Reel	-30°C to 85°C

NOTE: Parts that are ordered with an "LF" suffix to the part number are the Pb-Free configuration and are RoHS compliant.

While the information presented herein has been checked for both accuracy and reliability, Integrated Device Technology, Incorporated (IDT) assumes no responsibility for either its use or for infringement of any patents or other rights of third parties, which would result from its use. No other circuits, patents, or licenses are implied. This product is intended for use in normal commercial applications. Any other applications such as those requiring extended temperature ranges, high reliability or other extraordinary environmental requirements are not recommended without additional processing by IDT. IDT reserves the right to change any circuitry or specifications without notice. IDT does not authorize or warrant any IDT product for use in life support devices or critical medical instruments.

REVISION HISTORY SHEET

Rev	Table	Page	Description of Change	Date
A		1	Corrected block diagram.	6/1/04
B	T3A	3	Power Supply DC Characteristics Table- added ICCA spec.	8/23/04
B	T10	14	Ordering Information Table - corrected count from 154 to 100 per tube.	10/13/04
B	T10	1	Added Lead-Free bullet in Features section.	12/14/04
B	T10	14	Ordering Information Table - added "Lead-Free" part.	12/14/04
B	T10	14	Ordering Information Table - corrected Part/Order Number & Marking from ".AG" to ".BG".	12/04/06
B	T10	14	Ordering Information Table - changed Part/Order Number & Marking back to "AG" from ".BG".	12/06/06

Innovate with IDT and accelerate your future networks. Contact:

www.IDT.com

For Sales

800-345-7015
408-284-8200
Fax: 408-284-2775

For Tech Support

netcom@idt.com
480-763-2056

Corporate Headquarters

Integrated Device Technology, Inc.
6024 Silver Creek Valley Road
San Jose, CA 95138
United States
800 345 7015
+408 284 8200 (outside U.S.)

Asia Pacific and Japan

Integrated Device Technology
Singapore (1997) Pte. Ltd.
Reg. No. 199707558G
435 Orchard Road
#20-03 Wisma Atria
Singapore 238877
+65 6 887 5505

Europe

IDT Europe, Limited
321 Kingston Road
Leatherhead, Surrey
KT22 7TU
England
+44 (0) 1372 363 339
Fax: +44 (0) 1372 378851



www.IDT.com