



# FEMTOCLOCKS™ CRYSTAL-TO-LVCMOS/LVTTL CLOCK GENERATOR

ICS840011

## GENERAL DESCRIPTION



The ICS840011 is a Fibre Channel Clock Generator and a member of the HiPerClocks™ family of high performance devices from IDT. The ICS840011 uses a 26.5625MHz or 25MHz crystal to synthesize 106.25MHz or 100MHz respectively. The ICS840011 has excellent phase jitter performance, from 637kHz – 10MHz integration range. The ICS840011 is packaged in a small 8-pin TSSOP, making it ideal for use in systems with limited board space.

## FEATURES

- One LVCMOS/LVTTL output, 7Ω output impedance
- Crystal oscillator interface designed for 26.5625MHz or 25MHz, 18pF parallel resonant crystal
- Output frequency: 106.25MHz (typical)
- VCO range: 560MHz to 680MHz
- RMS phase jitter @ 106.25MHz, using a 26.5625MHz crystal (637KHz - 10MHz): 0.780ps (typical)
- RMS phase noise at 125MHz:
 

Offset	Noise Power
100Hz .....	-95.7 dBc/Hz
1kHz .....	-121 dBc/Hz
10kHz .....	-129 dBc/Hz
100kHz .....	-129.6 dBc/Hz
- 3.3V operating supply
- -30°C to 85°C ambient operating temperature
- Available in both standard (RoHS 5) and lead-free (RoHS 6) packages

## FREQUENCY TABLE

Inputs	Output Frequency (MHz)
Crystal Frequency (MHz)	
26.5625	106.25
25	100

## BLOCK DIAGRAM

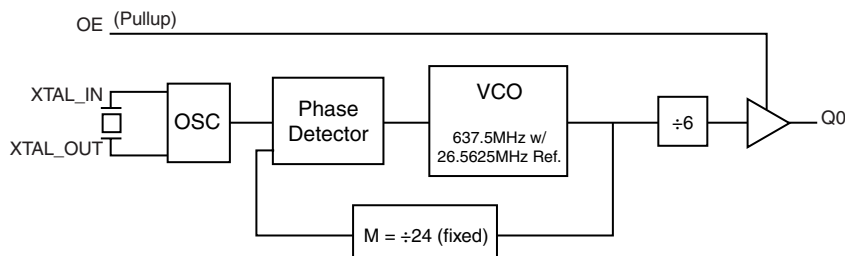

## PIN ASSIGNMENT

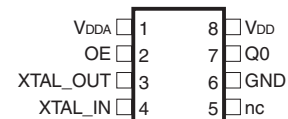

**ICS840011**

**8-Lead TSSOP**

4.40mm x 3.0mm x 0.925mm package body

**G Package**

Top View

**TABLE 1. PIN DESCRIPTIONS**

Number	Name	Type		Description
1	V <sub>DDA</sub>	Power		Analog supply pin.
2	OE	Input	Pullup	Output enable pin. When HIGH, Q0 output is enabled. When LOW, forces Q0 to HiZ state. LVCMOS/LVTTL interface levels.
3, 4	XTAL_OUT, XTAL_IN	Input		Crystal oscillator interface. XTAL_IN is the input, XTAL_OUT is the output.
5	nc	Unused		No connect.
6	GND	Power		Power supply ground.
7	Q0	Output		Single-ended clock output. LVCMOS/LVTTL interface levels. 7Ω output impedance.
8	V <sub>DD</sub>	Power		Core supply pin.

NOTE: *Pullup* refers to internal input resistors. See Table 2, Pin Characteristics, for typical values.

**TABLE 2. PIN CHARACTERISTICS**

Symbol	Parameter	Test Conditions	Minimum	Typical	Maximum	Units
C <sub>IN</sub>	Input Capacitance			4		pF
C <sub>PD</sub>	Power Dissipation Capacitance	V <sub>DD</sub> , V <sub>DDA</sub> = 3.465V		24		pF
R <sub>PULLUP</sub>	Input Pullup Resistor			51		kΩ
R <sub>OUT</sub>	Output Impedance		5	7	12	Ω

**TABLE 3. CONTROL FUNCTION TABLE**

Control Inputs	Output
<b>OE</b>	<b>Q0</b>
0	Hi-Z
1	Active

## ABSOLUTE MAXIMUM RATINGS

Supply Voltage, $V_{DD}$	4.6V
Inputs, $V_I$	-0.5V to $V_{DD} + 0.5$ V
Outputs, $V_O$	-0.5V to $V_{DD} + 0.5$ V
Package Thermal Impedance, $\theta_{JA}$	101.7°C/W (0 mps)
Storage Temperature, $T_{STG}$	-65°C to 150°C

NOTE: Stresses beyond those listed under Absolute Maximum Ratings may cause permanent damage to the device. These ratings are stress specifications only. Functional operation of product at these conditions or any conditions beyond those listed in the *DC Characteristics* or *AC Characteristics* is not implied. Exposure to absolute maximum rating conditions for extended periods may affect product reliability.

**TABLE 4A. POWER SUPPLY DC CHARACTERISTICS,  $V_{DD} = V_{DDA} = 3.3V \pm 5\%$ ,  $T_A = -30^\circ\text{C}$  TO  $85^\circ\text{C}$**

Symbol	Parameter	Test Conditions	Minimum	Typical	Maximum	Units
$V_{DD}$	Core Supply Voltage		3.135	3.3	3.465	V
$V_{DDA}$	Analog Supply Voltage		3.135	3.3	3.465	V
$I_{DD}$	Power Supply Current				80	mA
$I_{DDA}$	Analog Supply Current				10	mA

**TABLE 4B. LVCMOS/LVTTL DC CHARACTERISTICS,  $V_{DD} = V_{DDA} = 3.3V \pm 5\%$ ,  $T_A = -30^\circ\text{C}$  TO  $85^\circ\text{C}$**

Symbol	Parameter	Test Conditions	Minimum	Typical	Maximum	Units
$V_{IH}$	Input High Voltage		2		$V_{DD} + 0.3$	V
$V_{IL}$	Input Low Voltage		-0.3		0.8	V
$I_{IH}$	Input High Current	OE $V_{DD} = V_{IN} = 3.465$ V			5	$\mu$ A
$I_{IL}$	Input Low Current	OE $V_{DD} = 3.465$ V, $V_{IN} = 0$ V	-150			$\mu$ A
$V_{OH}$	Output High Voltage; NOTE 1		2.6			V
$V_{OL}$	Output Low Voltage; NOTE 1				0.5	V

NOTE 1: Outputs terminated with  $50\Omega$  to  $V_{DD}/2$ . See Parameter Measurement Information Section, "3.3V Output Load Test Circuit".

**TABLE 5. CRYSTAL CHARACTERISTICS**

Parameter	Test Conditions	Minimum	Typical	Maximum	Units
Mode of Oscillation		Fundamental			
Frequency				26.5625	MHz
Equivalent Series Resistance (ESR)				50	$\Omega$
Shunt Capacitance				7	pF

**TABLE 6. AC CHARACTERISTICS,  $V_{DD} = V_{DDA} = 3.3V \pm 5\%$ ,  $T_A = -30^\circ\text{C}$  TO  $85^\circ\text{C}$**

Symbol	Parameter	Test Conditions	Minimum	Typical	Maximum	Units
$f_{OUT}$	Output Frequency		93.33	106.25	113.33	MHz
$f_{jit}(\emptyset)$	RMS Phase Jitter (Random); NOTE 1	$f_{OUT} = 106.25$ MHz, (637kHz to 10MHz)		0.780		ps
$t_R / t_F$	Output Rise/Fall Time	20% to 80%	250		600	ps
odc	Output Duty Cycle	$f_{OUT} = 106.25$ MHz	48		52	%

All parameters are characterized @ 106.25MHz.

NOTE 1: Please refer to the Phase Noise Plot.

# TYPICAL PHASE NOISE AT 106.25MHz

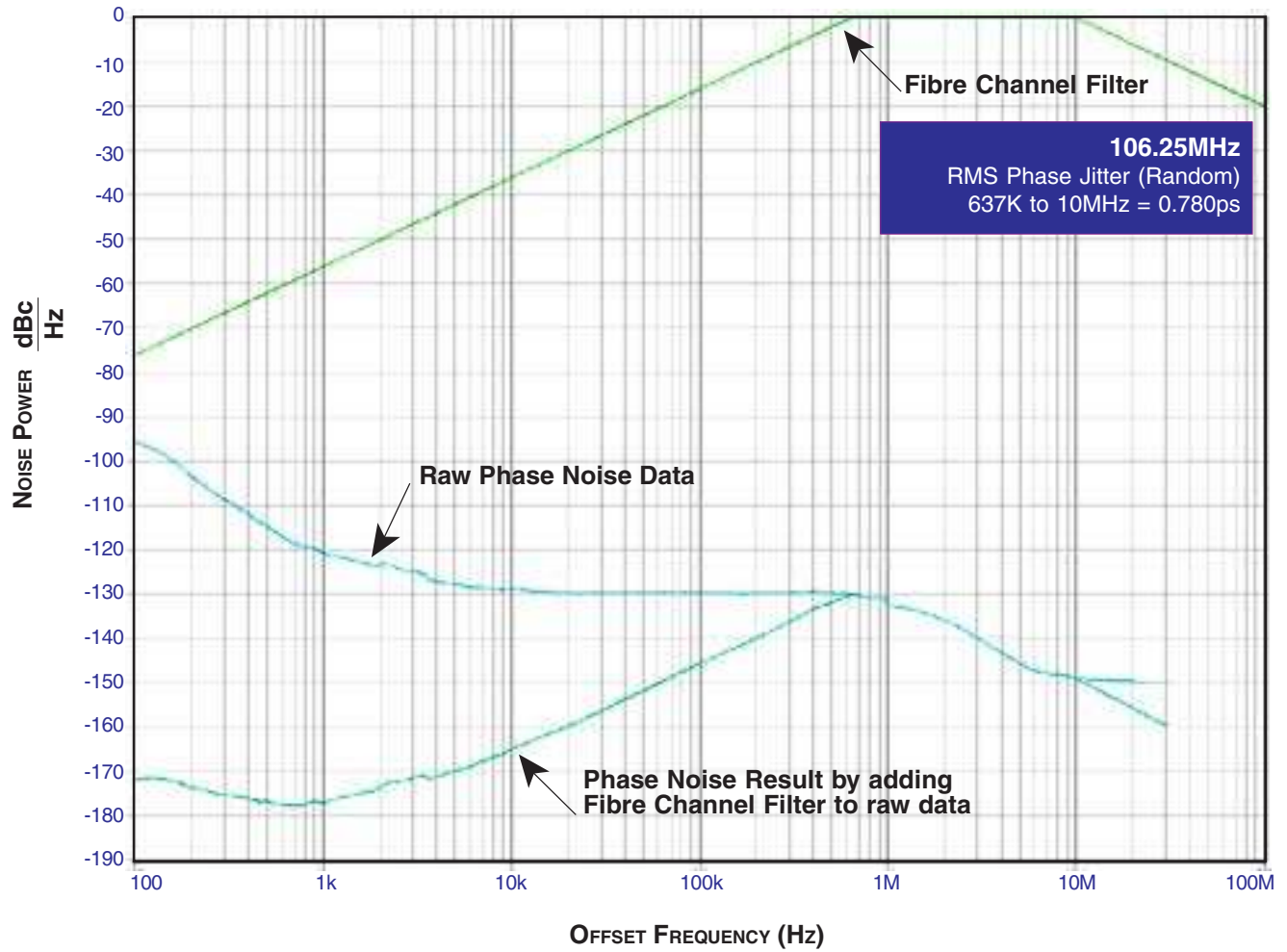

# PARAMETER MEASUREMENT INFORMATION

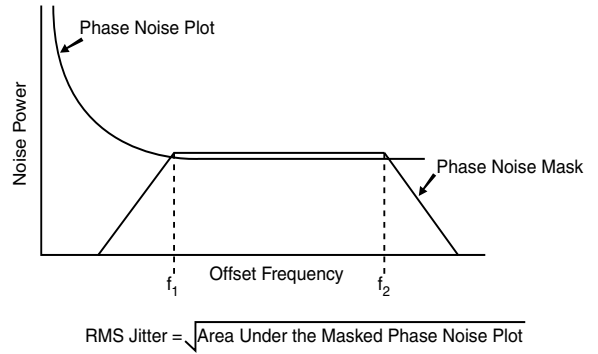
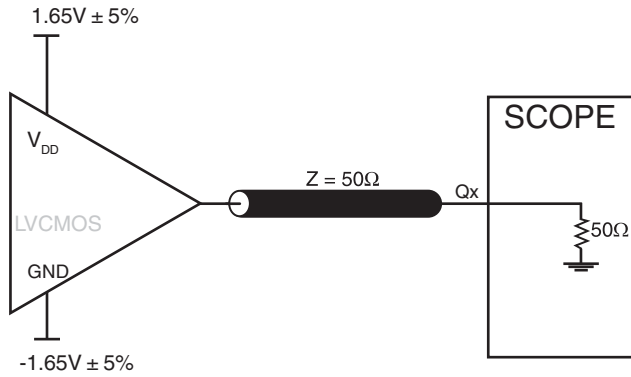

**3.3V LVC MOS OUTPUT LOAD AC TEST CIRCUIT**

**RMS PHASE JITTER**

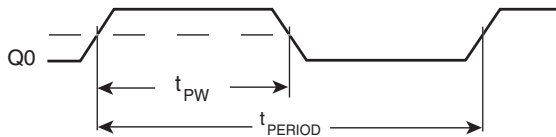

$$\text{odc} = \frac{t_{\text{PW}}}{t_{\text{PERIOD}}} \times 100\%$$

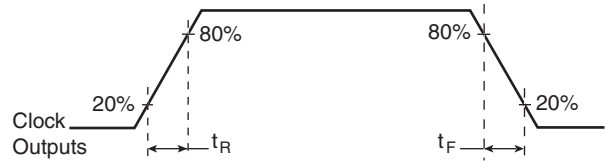

**LVC MOS OUTPUT DUTY CYCLE/PULSE WIDTH/PERIOD**

**LVC MOS OUTPUT RISE/FALL TIME**

# APPLICATION INFORMATION

## POWER SUPPLY FILTERING TECHNIQUES

As in any high speed analog circuitry, the power supply pins are vulnerable to random noise. The ICS840011 provides separate power supplies to isolate any high switching noise from the outputs to the internal PLL.  $V_{DD}$  and  $V_{DDA}$  should be individually connected to the power supply plane through vias, and bypass capacitors should be used for each pin. To achieve optimum jitter performance, power supply isolation is required. *Figure 1* illustrates how a  $10\Omega$  resistor along with a  $10\mu\text{F}$  and a  $.01\mu\text{F}$  bypass capacitor should be connected to each  $V_{DDA}$  pin.

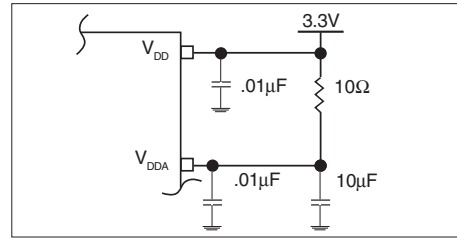

FIGURE 1. POWER SUPPLY FILTERING

## CRYSTAL INPUT INTERFACE

The ICS840011 has been characterized with  $18\text{pF}$  parallel resonant crystals. The capacitor values,  $C1$  and  $C2$ , shown in *Figure 2* below were determined using a  $26.5625\text{MHz}$ ,  $18\text{pF}$

parallel resonant crystal and were chosen to minimize the ppm error. The optimum  $C1$  and  $C2$  values can be slightly adjusted for different board layouts.

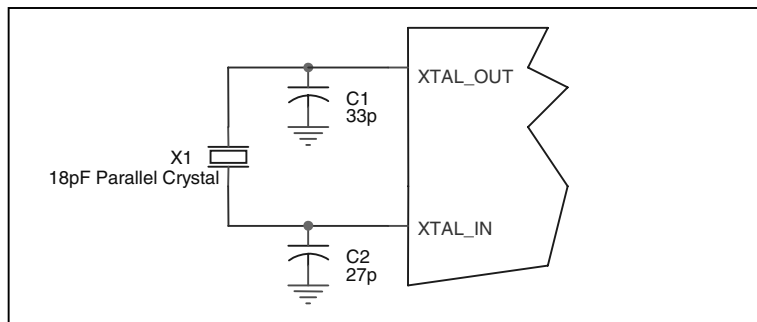
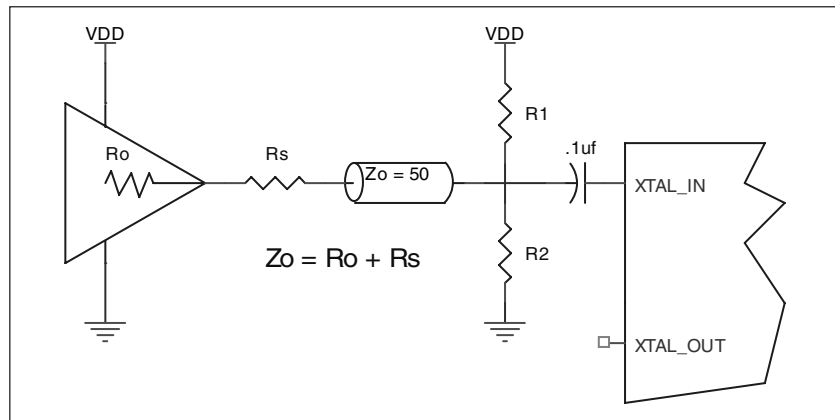

FIGURE 2. CRYSTAL INPUT INTERFACE

## LVC MOS TO XTAL INTERFACE

The XTAL\_IN input can accept a single-ended LVC MOS signal through an AC coupling capacitor. A general interface diagram is shown in *Figure 3*. The XTAL\_OUT pin can be left floating. The input edge rate can be as slow as 10ns. For LVC MOS inputs, it is recommended that the amplitude be reduced from full swing to half swing in order to prevent signal interference with the power rail and to reduce noise. This configuration requires that the output

impedance of the driver ( $R_o$ ) plus the series resistance ( $R_s$ ) equals the transmission line impedance. In addition, matched termination at the crystal input will attenuate the signal in half. This can be done in one of two ways. First,  $R_1$  and  $R_2$  in parallel should equal the transmission line impedance. For most  $50\Omega$  applications,  $R_1$  and  $R_2$  can be  $100\Omega$ . This can also be accomplished by removing  $R_1$  and making  $R_2$   $50\Omega$ .



**FIGURE 3. GENERAL DIAGRAM FOR LVC MOS DRIVER TO XTAL INPUT INTERFACE**

## APPLICATION SCHEMATIC

Figure 4A shows a schematic example of the ICS840011. An example of LVCMOS termination is shown in this schematic. Additional LVCMOS termination approaches are shown in the LVCMOS Termination Application Note. In this example, an 18pF parallel resonant 26.5625MHz crystal is used for generating

106.25MHz output frequency. The  $C1 = 27\text{pF}$  and  $C2\text{pF} = 33\text{pF}$  are recommended for frequency accuracy. For different board layout, the  $C1$  and  $C2$  values may be slightly adjusted for optimizing frequency accuracy.

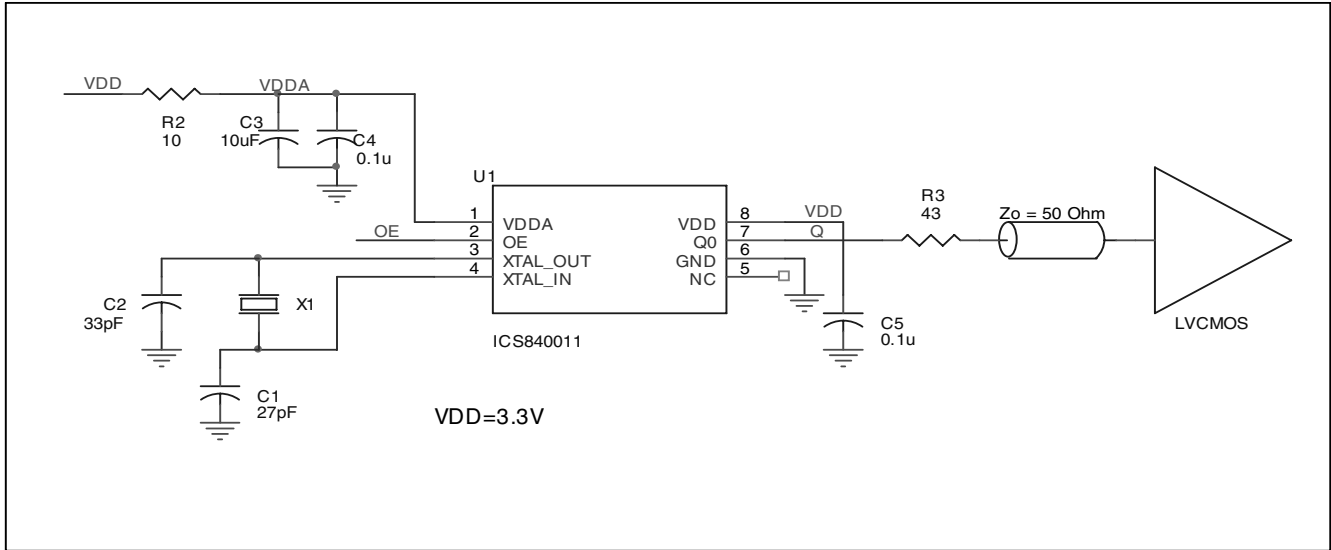

FIGURE 4A. ICS840011 SCHEMATIC EXAMPLE

## PC BOARD LAYOUT EXAMPLE

Figure 4B shows an example of ICS840011 P.C. board layout. The crystal X1 footprint in this example allows either surface mount (HC49S) or through hole (HC49) package. C3 is 0805. C1

and C2 are 0402. Other resistors and capacitors are 0603. This layout assumes that the board has clean analog power and ground planes.

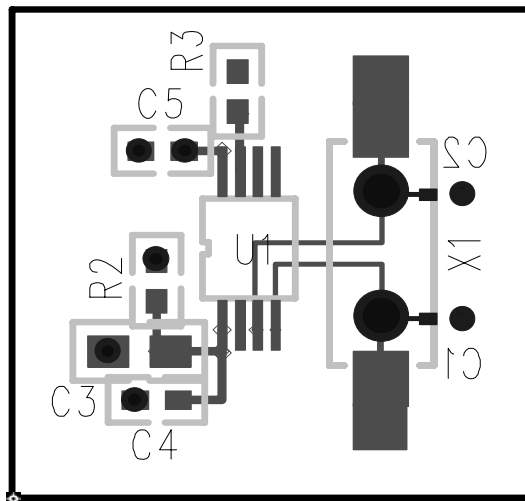

FIGURE 4B. ICS840011 PC BOARD LAYOUT EXAMPLE

# RELIABILITY INFORMATION

TABLE 7.  $\theta_{JA}$  VS. AIR FLOW TABLE FOR 8 LEAD TSSOP

$\theta_{JA}$ by Velocity (Meters per Second)			
	0	1	2.5
Multi-Layer PCB, JEDEC Standard Test Boards	101.7°C/W	90.5°C/W	89.8°C/W

## TRANSISTOR COUNT

The transistor count for ICS840011 is: 1521

PACKAGE OUTLINE - G SUFFIX FOR 8 LEAD TSSOP

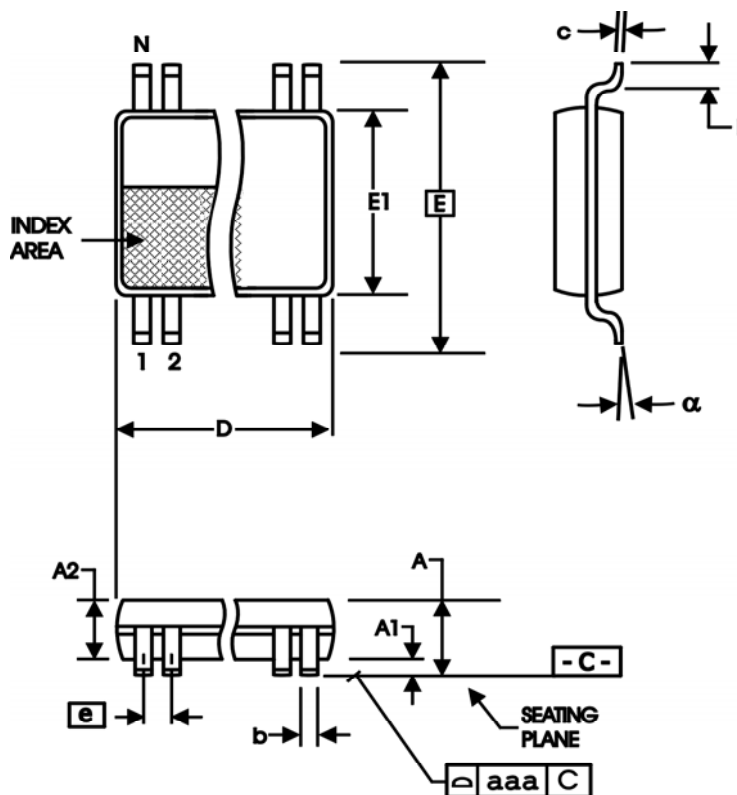

TABLE 8. PACKAGE DIMENSIONS

SYMBOL	Millimeters	
	Minimum	Maximum
N	8	
A	--	1.20
A1	0.05	0.15
A2	0.80	1.05
b	0.19	0.30
c	0.09	0.20
D	2.90	3.10
E	6.40 BASIC	
E1	4.30	4.50
e	0.65 BASIC	
L	0.45	0.75
$\alpha$	0°	8°
aaa	--	0.10

Reference Document: JEDEC Publication 95, MO-153

**TABLE 9. ORDERING INFORMATION**

<b>Part/Order Number</b>	<b>Marking</b>	<b>Package</b>	<b>Shipping Packaging</b>	<b>Temperature</b>
ICS840011AG	011A	8 lead TSSOP	tube	-30°C to 85°C
ICS840011AGT	011A	8 lead TSSOP	2500 tape & reel	-30°C to 85°C
ICS840011AGLN	011AN	8 lead "Lead Free Annealed" TSSOP	tube	-30°C to 85°C
ICS840011AGLNT	011AN	8 lead "Lead Free Annealed" TSSOP	2500 tape & reel	-30°C to 85°C

NOTE: Parts that are ordered with an "LF" suffix to the part number are the Pb-Free configuration and are RoHS compliant.

While the information presented herein has been checked for both accuracy and reliability, Integrated Device Technology, Incorporated (IDT) assumes no responsibility for either its use or for infringement of any patents or other rights of third parties, which would result from its use. No other circuits, patents, or licenses are implied. This product is intended for use in normal commercial applications. Any other applications such as those requiring high reliability or other extraordinary environmental requirements are not recommended without additional processing by IDT. IDT reserves the right to change any circuitry or specifications without notice. IDT does not authorize or warrant any IDT product for use in life support devices or critical medical instruments.

**REVISION HISTORY SHEET**

<b>Rev</b>	<b>Table</b>	<b>Page</b>	<b>Description of Change</b>	<b>Date</b>
A	T9	10	Ordering Information Table - corrected count from 154 per tube to 100.	10/15/04
A	T9	7 11	Added <i>LVC MOS to XTAL Interface</i> . Ordering Information Table - deleted quantity from tube count. Updated datasheet format.	1/22/07

**Innovate with IDT and accelerate your future networks. Contact:**

**www.IDT.com**

**For Sales**

800-345-7015  
408-284-8200  
Fax: 408-284-2775

**For Tech Support**

netcom@idt.com  
480-763-2056

---

**Corporate Headquarters**

Integrated Device Technology, Inc.  
6024 Silver Creek Valley Road  
San Jose, CA 95138  
United States  
800 345 7015  
+408 284 8200 (outside U.S.)

**Asia Pacific and Japan**

Integrated Device Technology  
Singapore (1997) Pte. Ltd.  
Reg. No. 199707558G  
435 Orchard Road  
#20-03 Wisma Atria  
Singapore 238877  
+65 6 887 5505

**Europe**

IDT Europe, Limited  
321 Kingston Road  
Leatherhead, Surrey  
KT22 7TU  
England  
+44 (0) 1372 363 339  
Fax: +44 (0) 1372 378851



www.IDT.com