

General Description



The ICS8400110I is a Low Jitter Telecom Rate-Conversion PLL that provides accurate and reliable frequency conversion.

The ICS8400110I generates a 65.536MHz clock that is either locked to the input reference or locked to the external crystal or oscillator.

In the locked mode, the reference input is continuously monitored for a failure condition. In the event of a failure, the PLL continues to provide a stable free-running clock, ensuring system reliability.

Features

- One 65.536MHz output, synchronized to 8kHz reference
- One 25MHz output, buffered version of the internal osc output
- Provides lock and reference fail indication
- Free run mode when reference clock (REF) fails
- Automatic switch-over to reference when good reference (REF) is available
- 25MHz external master clock source: crystal or oscillator
- Full 3.3V operation
- -40°C to 85°C ambient operating temperature
- Available in a lead-free (RoHS 6) package

Block Diagram

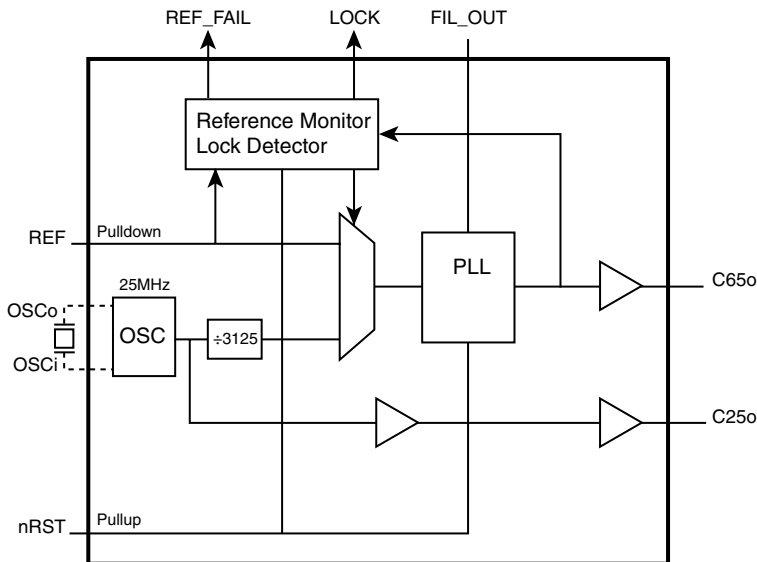

Pin Assignment

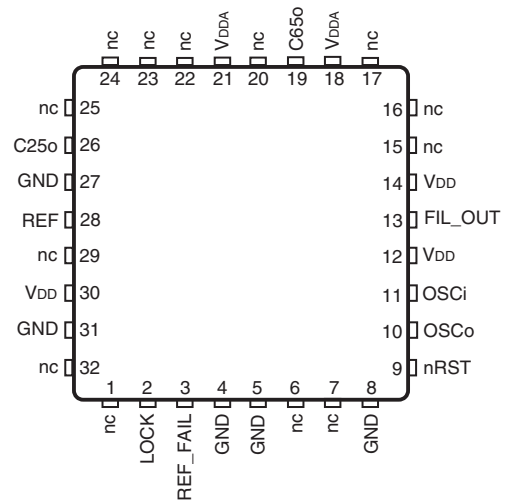

ICS8400110I

32-Lead VFQFN

5mm x 5mm x 0.925mm package body

K Package

Top View

Table 1. Pin Descriptions

Number	Name	Type		Description
1, 6, 7, 15, 16, 17, 20, 22, 23, 24, 25, 29, 32	nc	Unused		No connect.
2	LOCK	Output		Lock indicator. When HIGH, the PLL is frequency locked to a valid input reference. LVCMOS/LVTTL interface levels.
3	REF_FAIL	Output		Reference fail indicator. A logic HIGH at this output indicates that the reference (REF) frequency is exhibiting abrupt phase or frequency change. LVCMOS/LVTTL interface levels.
4, 5, 8, 27, 31	GND	Power		Power supply ground.
9	nRST	Input	Pullup	Reset. A logic LOW at this input resets the device. In Reset state, all outputs are forced into high-impedance. LVCMOS/LVTTL interface levels.
10	OSCo	Output		Crystal out.
11	OSCi	Input		Crystal in or single ended clock input.
12, 14, 30	V _{DD}	Power		Core supply pins.
13	FIL_OUT	Output		Filter output pin connected to 4.7 μ F capacitor.
18, 21	V _{DDA}	Power		Analog supply pins.
19	C65o	Output		Single-ended clock output, 65.536MHz frequency. This output is used for general TDM applications. LVCMOS/LVTTL interface levels.
26	C25o	Output		Single-ended clock output, 25MHz frequency. This is a buffered version of internal crystal oscillator. The phase and frequency accuracy of this output tracks that of the external crystal or oscillator. LVCMOS/LVTTL interface levels.
28	REF	Input	Pulldown	This is the input reference source used for synchronization. LVCMOS/LVTTL interface levels.

NOTE: *Pullup and Pulldown* refer to internal input resistors. See Table 2, *Pin Characteristics*, for typical values.

Table 2. Pin Characteristics

Symbol	Parameter	Test Conditions	Minimum	Typical	Maximum	Units
C _{IN}	Input Capacitance			4		pF
R _{PULLUP}	Input Pullup Resistor			51		k Ω
R _{PULLDOWN}	Input Pulldown Resistor			51		k Ω
R _{OUT}	Output Impedance	V _{DDO} = 3.6V		17		Ω

Functional Description

The PLL of ICS8400110I consists of a phase detector, a loop filter and a Voltage Controlled Oscillator (VCO). In the normal mode of operation, the VCO provides an output clock signal that is frequency and phase locked to the input reference clock (REF). In free-run mode, VCO is locked to 25MHz input with an accuracy equal to the accuracy of the OSCi 25MHz clock.

Lock Indicator

The Lock detector monitors if the output clock phase is within 90° of the input reference (REF). If the difference between input reference clock (REF) and output is more than 90° , LOCK output is LOW. The monitor then looks for eight consecutive clocks within 22.5° of the reference, before setting the LOCK to a HIGH.

REF_FAIL

The REF_FAIL signal is HIGH when reference clock (REF) shows greater than 130ppm variation in frequency, there are more than three consecutive edges missing, or there is an abrupt phase shift in the reference clock REF. Under any of these circumstances the PLL input will be switched from primary reference clock (REF) to crystal. When the primary reference clock (REF) is restored and REF_FAIL sets to LOW, the PLL input is switched back to the primary reference clock (REF).

Modes of Operation

The ICS8400110I device has two modes of operation; normal mode and free-run mode. The device powers up in free-run mode, it automatically transitions to normal mode if a valid reference clock (REF) is available and transitions to free-run mode if the reference fails. RESET signal also will put the device in free-run mode.

Freerun Mode

The freerun mode is typically used when an asynchronous clock source is required or it is used immediately following system power-up before synchronization is achieved. In free-run mode, ICS8400110I provides an output clock based on oscillator frequency. The output is not synchronized to the reference input clock (REF). In the free-run mode the accuracy of output frequency is equal to the accuracy of the frequency of the oscillator.

Normal Mode

The normal mode is typically used when a synchronous clock is required. In normal mode, ICS8400110I provides an output clock which is synchronized to the input (REF).

Lock Time

This is the time it takes the PLL to lock to the input reference clock REF. Lock occurs when the input signal and output signal are aligned in phase and frequency with respect to each other. LOCK time is affected by many factors which include:

- Initial input to output phase difference
- Initial input to output frequency difference
- PLL loop bandwidth

Absolute Maximum Ratings

NOTE: Stresses beyond those listed under *Absolute Maximum Ratings* may cause permanent damage to the device. These ratings are stress specifications only. Functional operation of product at these conditions or any conditions beyond those listed in the *DC Characteristics* or *AC Characteristics* is not implied. Exposure to absolute maximum rating conditions for extended periods may affect product reliability.

Item	Rating
Supply Voltage, V_{DD}	4.6V
Inputs, V_I	-0.5V to $V_{DD} + 0.5V$
Outputs, V_O	-0.5V to $V_{DD} + 0.5V$
Package Thermal Impedance, θ_{JA}	37°C/W
Storage Temperature, T_{STG}	-65°C to 150°C

DC Electrical Characteristics

Table 3A. Power Supply DC Characteristics, $V_{DD} = 3.3V \pm 0.3V$, $T_A = -40^\circ C$ to $85^\circ C$

Symbol	Parameter	Test Conditions	Minimum	Typical	Maximum	Units
V_{DD}	Core Supply Voltage		3.0	3.3	3.6	V
V_{DDA}	Analog Supply Voltage		$V_{DD} - 0.075$	3.3	V_{DD}	V
I_{DD}	Power Supply Current	Output Frequency = 65MHz			130	mA
I_{DDA}	Analog Supply Current	Output Frequency = 65MHz			15	mA

Table 3B. LVCMOS DC Characteristics, $V_{DD} = 3.3V \pm 0.3V$, $T_A = -40^\circ C$ to $85^\circ C$

Symbol	Parameter	Test Conditions	Minimum	Typical	Maximum	Units
V_{IH}	Input High Voltage		2		$V_{DD} + 0.3$	V
V_{IL}	Input Low Voltage		-0.3		0.8	V
I_{IH}	Input Current High	REF	$V_{DD} = V_{IN} = 3.6V$		150	μA
		nRST	$V_{DD} = V_{IN} = 3.6V$		5	μA
I_{IL}	Input Current Low	REF	$V_{DD} = 3.6V, V_{IN} = 0V$	-5		μA
		nRST	$V_{DD} = 3.6V, V_{IN} = 0V$	-150		μA
V_{OH}	Output High Voltage	C65o, C25o, REF_FAIL, LOCK	$V_{DD} = 3.6V, I_{OH} = -12mA$	2.6		V
V_{OL}	Output Low Voltage	C65o, C25o, REF_FAIL, LOCK	$V_{DD} = 3.6V, I_{OL} = 12mA$		0.5	V

Table 4. Crystal Characteristics

Parameter	Test Conditions	Minimum	Typical	Maximum	Units
Mode of Oscillation		Fundamental			
Frequency			25		MHz
Equivalent Series Resistance (ESR)				50	Ω
Shunt Capacitance				7	pF

AC Electrical Characteristics

Table 5. AC Characteristics, $V_{DD} = 3.3V \pm 0.3V$, $T_A = -40^{\circ}C$ to $85^{\circ}C$

Symbol	Parameter	Test Conditions	Minimum	Typical	Maximum	Units
t_{REFW}	Reference Pulse Width High or Low	$f = 8kHz$	15			ns
t_{C65L}	C65o Pulse Width Low	$f = 65.536MHz$	7.0		8	ns
t_{ORF}	Output Clock Rise or Fall Time	Rise/Fall Time, 20% to 80%, 15pF Load	1.05		2.1	ns
t_{C25L}	C25o Pulse Width Low		19		21	ns

NOTE: Electrical parameters are guaranteed over the specified ambient operating temperature range, which is established when the device is mounted in a test socket with maintained transverse airflow greater than 500 lpm. The device will meet specifications after thermal equilibrium has been reached under these conditions.

Performance Characteristics

Table 6. Functional Performance Characteristics

Characteristics	Test Conditions	Minimum	Typical	Maximum	Units
PLL Capture Range		-150		150	ppm
PLL Lock Time	REF = 8kHz			1	s
C65o Cycle-to-Cycle Jitter	C65o = 65.536MHz			100	ps
Peak-to-Peak Jitter C65.536; NOTE 1	C65o = 65.536MHz			175	ps
RMS Phase Jitter C25o	25MHz Crystal Input, 12kHz to 5MHz		1		ps

NOTE: Electrical parameters are guaranteed over the specified ambient operating temperature range, which is established when the device is mounted in a test socket with maintained transverse airflow greater than 500 lpm. The device will meet specifications after thermal equilibrium has been reached under these conditions.

NOTE 1: Peak-to-Peak jitter was calculated with RMS Period jitter data multiplied by BER 14.

Parameter Measurement Information

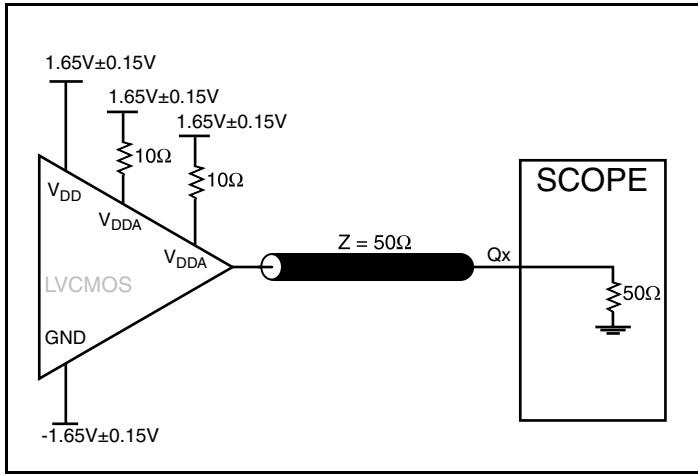

Output Load AC Test Circuit

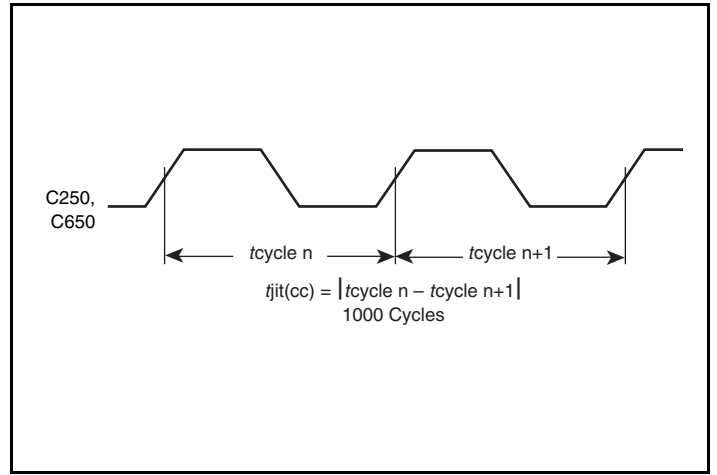

Cycle-to-Cycle Jitter

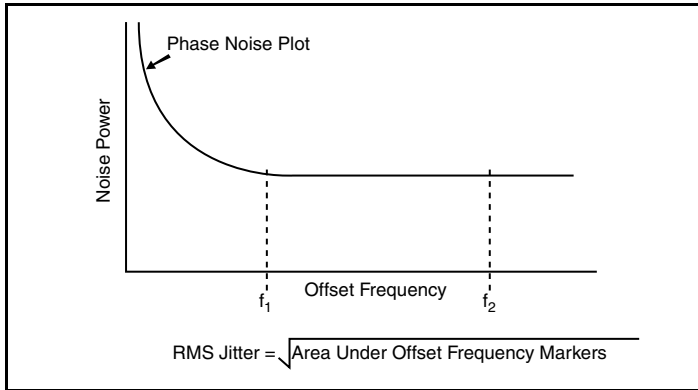

RMS Phase Jitter

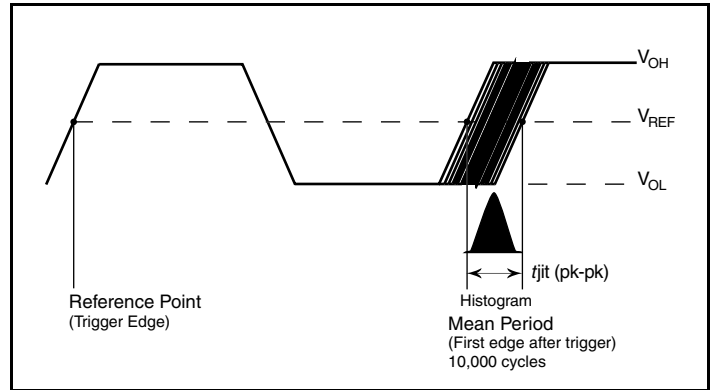

Period Jitter Peak-to-Peck

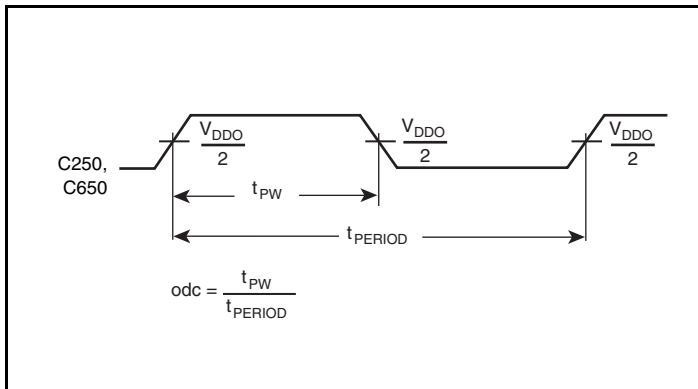

Output Pulse Width

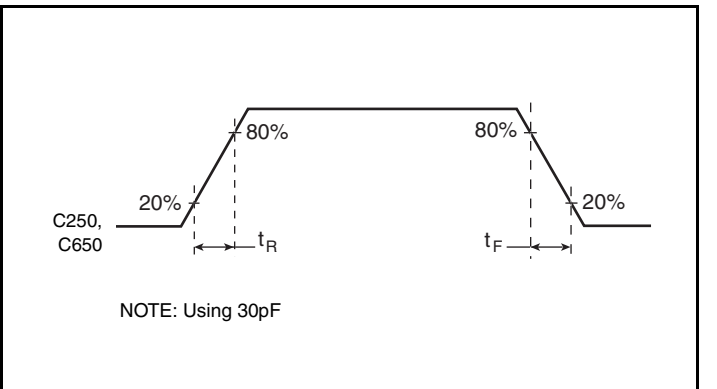

Output Rise/Fall Time

Parameter Measurement Information, continued

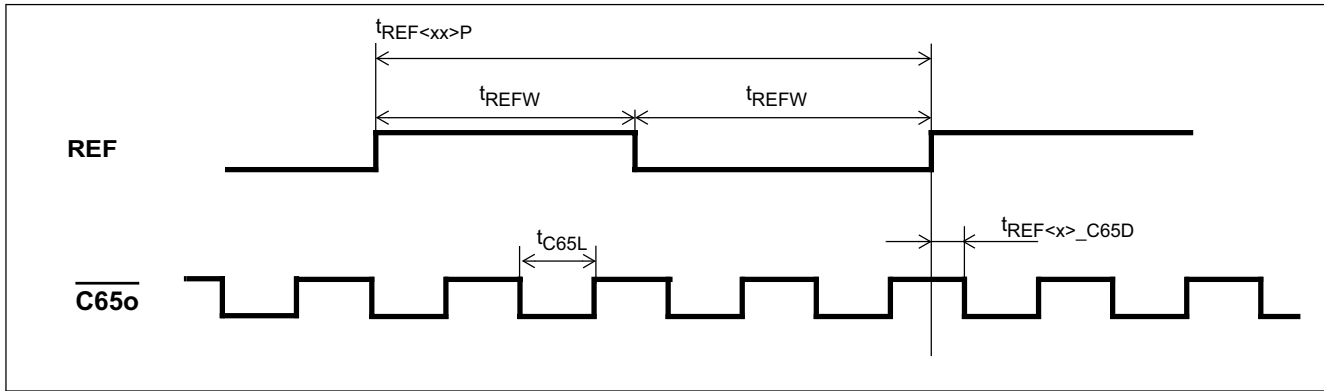

Input-to-Output Timing for Synchronous Clock

Application Information

Power Supply Filtering Technique

As in any high speed analog circuitry, the power supply pins are vulnerable to random noise. To achieve optimum jitter performance, power supply isolation is required. The ICS8400110I provides separate power supplies to isolate any high switching noise from the outputs to the internal PLL. V_{DD} and V_{DDA} should be individually connected to the power supply plane through vias, and $0.01\mu\text{F}$ bypass capacitors should be used for each pin. *Figure 1* illustrates this for a generic V_{DD} pin and also shows that V_{DDA} requires that an additional 10Ω resistor along with a $10\mu\text{F}$ bypass capacitor be connected to the V_{DDA} pin.

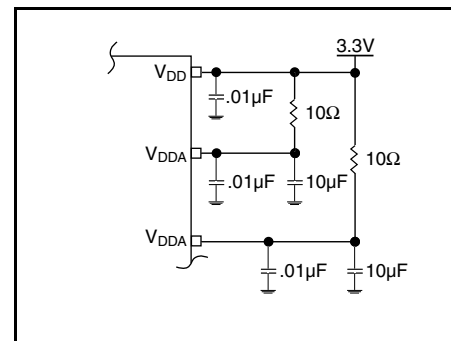

Figure 1. Power Supply Filtering

Crystal Input Interface

The ICS8400110I has been characterized with 18pF parallel resonant crystals. The capacitor values, C1 and C2, shown in *Figure 2* below were determined using a 25MHz, 18pF parallel resonant

crystal and were chosen to minimize the ppm error. The optimum C1 and C2 values can be slightly adjusted for different board layouts.

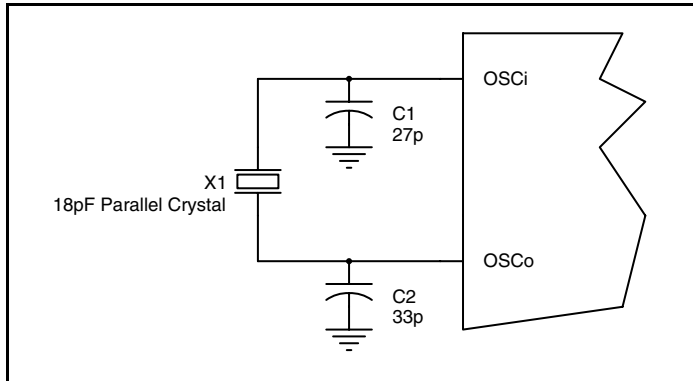

Figure 2. Crystal Input Interface

LVC MOS to XTAL Interface

The OSCi input can accept a single-ended LVC MOS signal through an AC coupling capacitor. A general interface diagram is shown in *Figure 3*. The OSCo pin can be left floating. The input edge rate can be as slow as 10ns. For LVC MOS signals, it is recommended that the amplitude be reduced from full swing to half swing in order to prevent signal interference with the power rail and to reduce noise. This configuration requires that the output impedance of the driver (R_o) plus the series resistance (R_s) equals the transmission line

impedance. In addition, matched termination at the crystal input will attenuate the signal in half. This can be done in one of two ways. First, R1 and R2 in parallel should equal the transmission line impedance. For most 50Ω applications, R1 and R2 can be 100Ω. This can also be accomplished by removing R1 and making R2 50Ω. By overdriving the crystal oscillator, the device will be functional, but note, the device performance is guaranteed by using a quartz crystal.

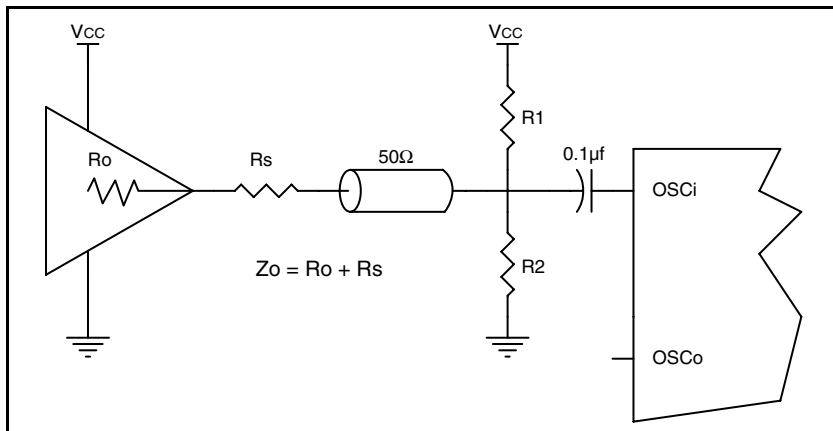

Figure 3. General Diagram for LVC MOS Driver to XTAL Input Interface

VFQFN EPAD Thermal Release Path

In order to maximize both the removal of heat from the package and the electrical performance, a land pattern must be incorporated on the Printed Circuit Board (PCB) within the footprint of the package corresponding to the exposed metal pad or exposed heat slug on the package, as shown in *Figure 4*. The solderable area on the PCB, as defined by the solder mask, should be at least the same size/shape as the exposed pad/slug area on the package to maximize the thermal/electrical performance. Sufficient clearance should be designed on the PCB between the outer edges of the land pattern and the inner edges of pad pattern for the leads to avoid any shorts.

While the land pattern on the PCB provides a means of heat transfer and electrical grounding from the package to the board through a solder joint, thermal vias are necessary to effectively conduct from the surface of the PCB to the ground plane(s). The land pattern must be connected to ground through these vias. The vias act as “heat pipes”. The number of vias (i.e. “heat pipes”) are application specific

and dependent upon the package power dissipation as well as electrical conductivity requirements. Thus, thermal and electrical analysis and/or testing are recommended to determine the minimum number needed. Maximum thermal and electrical performance is achieved when an array of vias is incorporated in the land pattern. It is recommended to use as many vias connected to ground as possible. It is also recommended that the via diameter should be 12 to 13mils (0.30 to 0.33mm) with 1oz copper via barrel plating. This is desirable to avoid any solder wicking inside the via during the soldering process which may result in voids in solder between the exposed pad/slug and the thermal land. Precautions should be taken to eliminate any solder voids between the exposed heat slug and the land pattern. Note: These recommendations are to be used as a guideline only. For further information, please refer to the Application Note on the Surface Mount Assembly of Amkor’s Thermally/Electrically Enhance Leadframe Base Package, Amkor Technology.

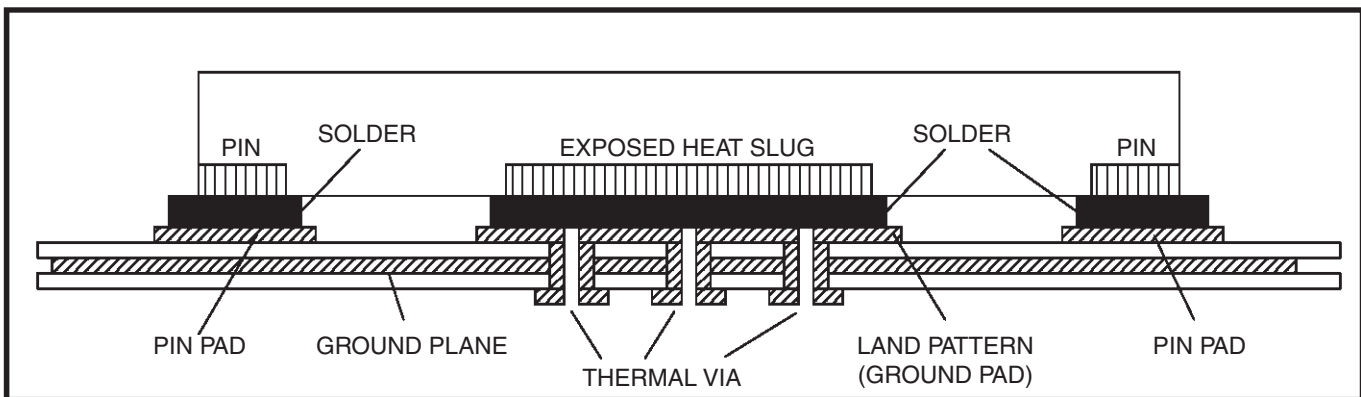

Figure 4. P.C. Assembly for Exposed Pad Thermal Release Path – Side View (drawing not to scale)

Power Considerations

This section provides information on power dissipation and junction temperature for the ICS8400110I. Equations and example calculations are also provided.

1. Power Dissipation.

The total power dissipation for the ICS8400110I is the sum of the core power plus the analog power plus the power dissipation in the load(s). The following is the power dissipation for $V_{DD} = 3.3V + 0.3V = 3.6V$, which gives worst case results.

- Power (core)_{MAX} = $V_{DD_MAX} * (I_{DD} + I_{DDA}) = 3.6V * (130mA + 15mA) = \mathbf{522mW}$
- Output Impedance R_{OUT} Power Dissipation due to Loading 50Ω to $V_{DD}/2$
Output Current $I_{OUT} = V_{DD_MAX} / [2 * (50\Omega + R_{OUT})] = 3.6V / [2 * (50\Omega + 17\Omega)] = \mathbf{26.9mA}$
- Power Dissipation on the R_{OUT} per LVCMOS output
Power $(R_{OUT}) = R_{OUT} * (I_{OUT})^2 = 17\Omega * (26.9mA)^2 = \mathbf{12.3mW}$ per output
- Total Power Dissipation on the R_{OUT}
Total Power (R_{OUT}) = $12.3mW * 2 = \mathbf{24.6mW}$

Total Power Dissipation

- **Total Power**
= Power (core)_{MAX} + Total Power (R_{OUT})
= $522mW + 24.6mW$
= **546.6mW**

2. Junction Temperature.

Junction temperature, T_j , is the temperature at the junction of the bond wire and bond pad, and directly affects the reliability of the device. The maximum recommended junction temperature for HiPerClockS devices is 125°C . Limiting the internal transistor junction temperature, T_j , to 125°C ensures that the bond wire and bond pad temperature remains below 125°C .

The equation for T_j is as follows: $T_j = \theta_{JA} * Pd_total + T_A$

T_j = Junction Temperature

θ_{JA} = Junction-to-Ambient Thermal Resistance

Pd_total = Total Device Power Dissipation (example calculation is in section 1 above)

T_A = Ambient Temperature

In order to calculate junction temperature, the appropriate junction-to-ambient thermal resistance θ_{JA} must be used. Assuming no air flow and a multi-layer board, the appropriate value is 37°C/W per Table 7 below.

Therefore, T_j for an ambient temperature of 85°C with all outputs switching is:

$$85^\circ\text{C} + 0.547W * 37^\circ\text{C/W} = 105.2^\circ\text{C}. \text{ This is below the limit of } 125^\circ\text{C}.$$

This calculation is only an example. T_j will obviously vary depending on the number of loaded outputs, supply voltage, air flow and the type of board (multi-layer).

Table 7. Thermal Resistance θ_{JA} for 32 Lead VFQFN, Forced Convection

Meters per Second	θ_{JA} by Velocity		
	0	1	2.5
Multi-Layer PCB, JEDEC Standard Test Boards	37.0°C/W	32.4°C/W	29.0°C/W

Reliability Information

Table 8. θ_{JA} vs. Air Flow Table for a 32 Lead VFQFN

θ_{JA} by Velocity			
Meters per Second	0	1	2.5
Multi-Layer PCB, JEDEC Standard Test Boards	37.0°C/W	32.4°C/W	29.0°C/W

Transistor Count

The transistor count for ICS8400110I is: 4007

Package Outline and Package Dimensions

Package Outline - K Suffix for 32 Lead VFQFN

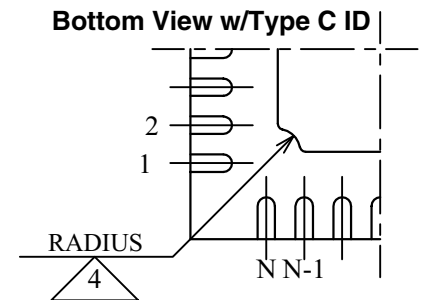
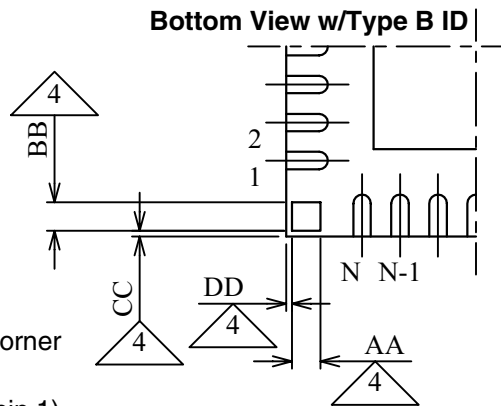
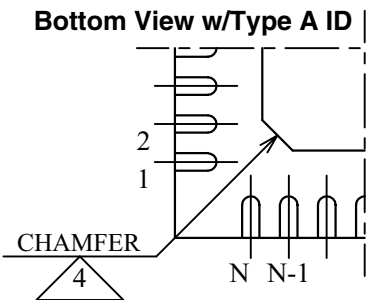
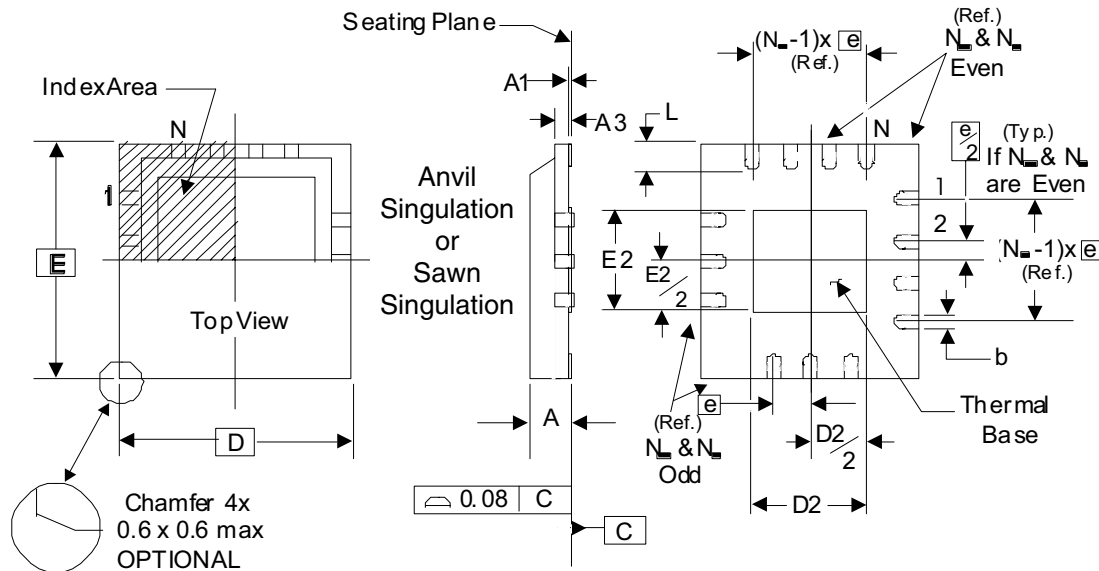

There are 3 methods of indicating pin 1 corner at the back of the VFQFN package are:

1. Type A: Chamfer on the paddle (near pin 1)
2. Type B: Dummy pad between pin 1 and N.
3. Type C: Mouse bite on the paddle (near pin 1)

Table 9. Package Dimensions for 32 Lead VFQFN

JEDEC Variation: VHHD-2/-4 All Dimensions in Millimeters			
Symbol	Minimum	Nominal	Maximum
N	32		
A	0.80		1.00
A1	0		0.05
A3	0.25 Ref.		
b	0.18	0.25	0.30
N_D & N_E			8
D & E	5.00 Basic		
D2 & E2	3.0		3.3
e	0.50 Basic		
L	0.30	0.40	0.50

NOTE: The following package mechanical drawing is a generic drawing that applies to any pin count VFQFN package. This drawing is not intended to convey the actual pin count or pin layout of this device. The pin count and pinout are shown on the front page. The package dimensions are in Table 9.

Ordering Information

Table 10. Ordering Information

Part/Order Number	Marking	Package	Shipping Packaging	Temperature
8400110EKILF	ICS00110EIL	"Lead-Free" 32 Lead VFQFN	Tray	-40°C to 85°C
8400110EKILFT	ICS00110EIL	"Lead-Free" 32 Lead VFQFN	2500 Tape & Reel	-40°C to 85°C

NOTE: Parts that are ordered with an "LF" suffix to the part number are the Pb-Free configuration and are RoHS compliant.

While the information presented herein has been checked for both accuracy and reliability, Integrated Device Technology (IDT) assumes no responsibility for either its use or for the infringement of any patents or other rights of third parties, which would result from its use. No other circuits, patents, or licenses are implied. This product is intended for use in normal commercial and industrial applications. Any other applications, such as those requiring high reliability or other extraordinary environmental requirements are not recommended without additional processing by IDT. IDT reserves the right to change any circuitry or specifications without notice. IDT does not authorize or warrant any IDT product for use in life support devices or critical medical instruments.



www.IDT.com

6024 Silver Creek Valley Road
San Jose, California 95138

Sales
800-345-7015 (inside USA)
+408-284-8200 (outside USA)
Fax: 408-284-2775
www.IDT.com/go/contactIDT

Technical Support
netcom@idt.com
+480-763-2056

DISCLAIMER Integrated Device Technology, Inc. (IDT) and its subsidiaries reserve the right to modify the products and/or specifications described herein at any time and at IDT's sole discretion. All information in this document, including descriptions of product features and performance, is subject to change without notice. Performance specifications and the operating parameters of the described products are determined in the independent state and are not guaranteed to perform the same way when installed in customer products. The information contained herein is provided without representation or warranty of any kind, whether express or implied, including, but not limited to, the suitability of IDT's products for any particular purpose, an implied warranty of merchantability, or non-infringement of the intellectual property rights of others. This document is presented only as a guide and does not convey any license under intellectual property rights of IDT or any third parties.

IDT's products are not intended for use in life support systems or similar devices where the failure or malfunction of an IDT product can be reasonably expected to significantly affect the health or safety of users. Anyone using an IDT product in such a manner does so at their own risk, absent an express, written agreement by IDT.

Integrated Device Technology, IDT and the IDT logo are registered trademarks of IDT. Other trademarks and service marks used herein, including protected names, logos and designs, are the property of IDT or their respective third party owners.

Copyright 2009. All rights reserved.